

# DATA SHEET

## **74LVU04** Hex inverter

Product specification  
Supersedes data of 2000 Dec 18

2001 Jan 11

## Hex inverter

## 74LVU04

## FEATURES

- Wide operating voltage: 1.0 to 5.5 V
- Optimized for Low Voltage applications: 1.0 to 3.6 V
- Typical  $V_{OLP}$  (output ground bounce) < 0.8 V at  $V_{CC} = 3.3$  V,  $T_{amb} = 25$  °C.
- Typical  $V_{OHV}$  (output  $V_{OH}$  undershoot) > 2 V at  $V_{CC} = 3.3$  V,  $T_{amb} = 25$  °C.
- Output capability: standard
- $I_{CC}$  category: SSI

## DESCRIPTION

The 74LVU04 is a low-voltage, Si-gate CMOS device and is pin compatible with the 74HCU04.

The 74LVU04 is a general purpose hex inverter. Each of the six inverters is a single stage with unbuffered outputs.

## QUICK REFERENCE DATA

GND = 0 V;  $T_{amb} = 25$  °C;  $t_r = t_f \leq 2.5$  ns

SYMBOL	PARAMETER	CONDITIONS	TYPICAL	UNIT
$t_{PHL}/t_{PLH}$	Propagation delay nA to nY	$C_L = 15$ pF; $V_{CC} = 3.3$ V	6	ns
$C_I$	Input capacitance		3.5	pF
$C_{PD}$	Power dissipation capacitance per gate	Notes 1, 2	18	pF

## NOTES:

1.  $C_{PD}$  is used to determine the dynamic power dissipation ( $P_D$  in  $\mu$ W)  
 $P_D = C_{PD} \times V_{CC}^2 \times f_i + \Sigma (C_L \times V_{CC}^2 \times f_o)$  where:  
 $f_i$  = input frequency in MHz;  $C_L$  = output load capacitance in pF;  
 $f_o$  = output frequency in MHz;  $V_{CC}$  = supply voltage in V;  
 $\Sigma (C_L \times V_{CC}^2 \times f_o)$  = sum of the outputs.
2. The condition is  $V_I = GND$  to  $V_{CC}$ .

## ORDERING INFORMATION

PACKAGES	TEMPERATURE RANGE	OUTSIDE NORTH AMERICA	NORTH AMERICA	PKG. DWG. #
14-Pin Plastic DIL	-40 to +125 °C	74LVU04N	74LVU04N	SOT27-1
14-Pin Plastic SO	-40 to +125 °C	74LVU04D	74LVU04D	SOT108-1
14-Pin Plastic SSOP Type II	-40 to +125 °C	74LVU04DB	74LVU04DB	SOT337-1
14-Pin Plastic TSSOP Type I	-40 to +125 °C	74LVU04PW	74LVU04PWDH	SOT402-1

## PIN DESCRIPTION

PIN NUMBER	SYMBOL	NAME AND FUNCTION
1, 3, 5, 9, 11, 13	1A – 6A	Data inputs
2, 4, 6, 8, 10, 12	1Y – 6Y	Data outputs
7	GND	Ground (0 V)
14	$V_{CC}$	Positive supply voltage

## FUNCTION TABLE

INPUTS	OUTPUTS
nA	nY
L	H
H	L

## NOTES:

H = HIGH voltage level  
L = LOW voltage level

# Hex inverter

# 74LVU04

## PIN CONFIGURATION

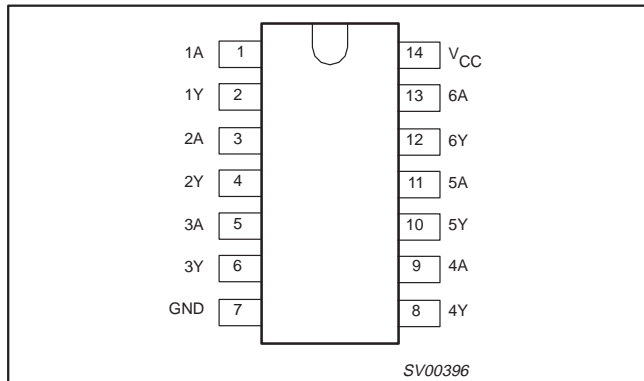

## LOGIC SYMBOL

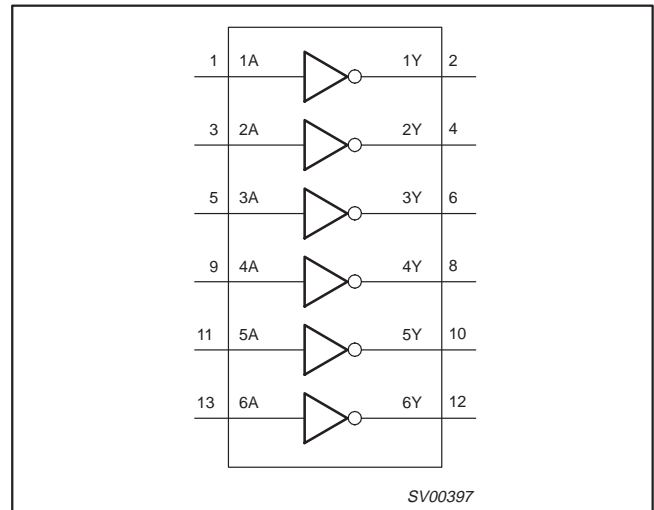

## LOGIC SYMBOL (IEEE/IEC)

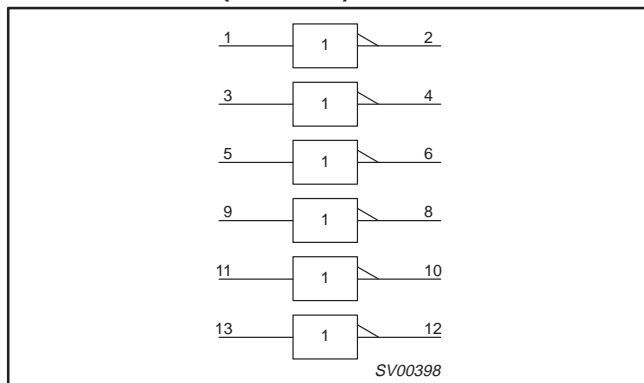

## SCHEMATIC DIAGRAM (ONE INVERTER)

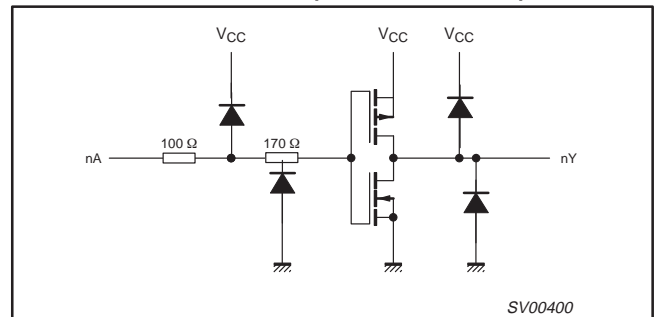

## RECOMMENDED OPERATING CONDITIONS

SYMBOL	PARAMETER	CONDITIONS	MIN	TYP.	MAX	UNIT
$V_{CC}$	DC supply voltage	See Note 1	1.0	3.3	5.5	V
$V_I$	Input voltage		0	–	$V_{CC}$	V
$V_O$	Output voltage		0	–	$V_{CC}$	V
$T_{amb}$	Operating ambient temperature range in free air	See DC and AC characteristics	–40		+85	°C
			–40		+125	
$t_r, t_f$	Input rise and fall times	$V_{CC} = 1.0$ to $2.0$ V	–	–	500	ns/V
		$V_{CC} = 2.0$ to $2.7$ V	–	–	200	
		$V_{CC} = 2.7$ to $3.6$ V	–	–	100	
		$V_{CC} = 3.6$ to $5.5$ V	–	–	50	

**NOTE:**

- The LV is guaranteed to function down to  $V_{CC} = 1.0$  V (input levels GND or  $V_{CC}$ ); DC characteristics are guaranteed from  $V_{CC} = 1.2$  V to  $V_{CC} = 5.5$  V.

## Hex inverter

74LVU04

**ABSOLUTE MAXIMUM RATINGS<sup>1, 2</sup>**

In accordance with the Absolute Maximum Rating System (IEC 134).

Voltages are referenced to GND (ground = 0 V).

SYMBOL	PARAMETER	CONDITIONS	RATING	UNIT
$V_{CC}$	DC supply voltage		-0.5 to +7.0	V
$\pm I_{IK}$	DC input diode current	$V_I < -0.5$ or $V_I > V_{CC} + 0.5$ V	20	mA
$\pm I_{OK}$	DC output diode current	$V_O < -0.5$ or $V_O > V_{CC} + 0.5$ V	50	mA
$\pm I_O$	DC output source or sink current – standard outputs	$-0.5$ V < $V_O$ < $V_{CC} + 0.5$ V	25	mA
$\pm I_{GND}$ , $\pm I_{CC}$	DC $V_{CC}$ or GND current for types with – standard outputs		50	mA
$T_{stg}$	Storage temperature range		-65 to +150	°C
$P_{TOT}$	Power dissipation per package – plastic DIL – plastic mini-pack (SO) – plastic shrink mini-pack (SSOP and TSSOP)	for temperature range: -40 to +125 °C above +70 °C derate linearly with 12 mW/K above +70 °C derate linearly with 8 mW/K above +60 °C derate linearly with 5.5 mW/K	750 500 400	mW

**NOTES:**

- Stresses beyond those listed may cause permanent damage to the device. These are stress ratings only and functional operation of the device at these or any other conditions beyond those indicated under “recommended operating conditions” is not implied. Exposure to absolute-maximum-rated conditions for extended periods may affect device reliability.
- The input and output voltage ratings may be exceeded if the input and output current ratings are observed.

**DC ELECTRICAL CHARACTERISTICS**

Over recommended operating conditions. Voltages are referenced to GND (ground = 0 V).

SYMBOL	PARAMETER	TEST CONDITIONS	LIMITS					UNIT
			-40 to +85 °C			-40 to +125 °C		
			MIN	TYP <sup>1</sup>	MAX	MIN	MAX	
$V_{IH}$	HIGH level Input voltage	$V_{CC} = 1.2$ V	1.0			1.0		V
		$V_{CC} = 2.0$ V	1.6			1.6		
		$V_{CC} = 2.7$ to $3.6$ V	2.4			2.4		
		$V_{CC} = 4.5$ to $5.5$ V	$0.8 \cdot V_{CC}$			$0.8 \cdot V_{CC}$		
$V_{IL}$	LOW level Input voltage	$V_{CC} = 1.2$ V			0.2		0.2	V
		$V_{CC} = 2.0$ V			0.4		0.4	
		$V_{CC} = 2.7$ to $3.6$ V			0.5		0.5	
		$V_{CC} = 4.5$ to $5.5$ V			$0.2 \cdot V_{CC}$		$0.2 \cdot V_{CC}$	
$V_{OH}$	HIGH level output voltage	$V_{CC} = 1.2$ V; $V_I = V_{IH}$ or $V_{IL}$ ; $-I_O = 100$ $\mu$ A		1.2				V
		$V_{CC} = 2.0$ V; $V_I = V_{IH}$ or $V_{IL}$ ; $-I_O = 100$ $\mu$ A	1.8	2.0		1.8		
		$V_{CC} = 2.7$ V; $V_I = V_{IH}$ or $V_{IL}$ ; $-I_O = 100$ $\mu$ A	2.5	2.7		2.5		
		$V_{CC} = 3.0$ V; $V_I = V_{IH}$ or $V_{IL}$ ; $-I_O = 100$ $\mu$ A	2.8	3.0		2.8		
		$V_{CC} = 4.5$ V; $V_I = V_{IH}$ or $V_{IL}$ ; $-I_O = 100$ $\mu$ A	4.3	4.5		4.3		
$V_{OH}$	HIGH level output voltage	$V_{CC} = 3.0$ V; $V_I = V_{IH}$ or $V_{IL}$ ; $-I_O = 6$ mA	2.40	2.82		2.20		V
		$V_{CC} = 4.5$ V; $V_I = V_{IH}$ or $V_{IL}$ ; $-I_O = 12$ mA	3.60	4.20		3.50		
$V_{OL}$	LOW level output voltage	$V_{CC} = 1.2$ V; $V_I = V_{IH}$ or $V_{IL}$ ; $I_O = 100$ $\mu$ A		0				V
		$V_{CC} = 2.0$ V; $V_I = V_{IH}$ or $V_{IL}$ ; $I_O = 100$ $\mu$ A		0	0.2		0.2	
		$V_{CC} = 2.7$ V; $V_I = V_{IH}$ or $V_{IL}$ ; $I_O = 100$ $\mu$ A		0	0.2		0.2	
		$V_{CC} = 3.0$ V; $V_I = V_{IH}$ or $V_{IL}$ ; $I_O = 100$ $\mu$ A		0	0.2		0.2	
		$V_{CC} = 4.5$ V; $V_I = V_{IH}$ or $V_{IL}$ ; $I_O = 100$ $\mu$ A		0	0.2		0.2	
$V_{OL}$	LOW level output voltage	$V_{CC} = 3.0$ V; $V_I = V_{IH}$ or $V_{IL}$ ; $I_O = 6$ mA		0.25	0.40		0.50	V
		$V_{CC} = 4.5$ V; $V_I = V_{IH}$ or $V_{IL}$ ; $I_O = 12$ mA		0.35	0.55		0.65	
$\pm I_I$	Input leakage current	$V_{CC} = 5.5$ V; $V_I = V_{CC}$ or GND			1.0		1.0	$\mu$ A
$I_{CC}$	Quiescent supply current	$V_{CC} = 5.5$ V; $V_I = V_{CC}$ or GND; $I_O = 0$			20.0		40.0	$\mu$ A

**NOTE:**

- All typical values are measured at  $T_{amb} = 25$  °C.

# Hex inverter

# 74LVU04

## AC CHARACTERISTICS

GND = 0 V;  $t_r = t_f = 2.5$  ns;  $C_L = 50$  pF;  $R_L = 500 \Omega$

SYMBOL	PARAMETER	WAVEFORM	CONDITION	LIMITS				UNIT	
				-40 to +85 °C			-40 to +125 °C		
				MIN	TYP <sup>1</sup>	MAX	MIN		MAX
$t_{PHL/PLH}$	Propagation delay nA to nY	Figure 1	$V_{CC}(V)$					ns	
			1.2		35				
			2.0		12	14	17		
			2.7		9	10	13		
			3.0 to 3.6		7 <sup>2</sup>	8	10		
4.5 to 5.5			7		9				

**NOTES:**

1. Unless otherwise stated, all typical values are measured at  $T_{amb} = 25$  °C
2. Typical values are measured at  $V_{CC} = 3.3$  V.

## AC WAVEFORMS

$V_M = 1.5$  V at  $V_{CC} \geq 2.7$  V and  $\leq 3.6$  V

$V_M = 0.5 \times V_{CC}$  at  $V_{CC} < 2.7$  V and  $\geq 4.5$  V

$V_{OL}$  and  $V_{OH}$  are the typical output voltage drop that occur with the output load.

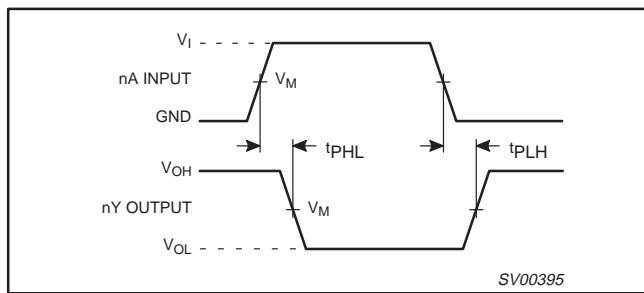

Figure 1. Input (nA) to output (nY) propagation delays and output transition times.

## TYPICAL TRANSFER CHARACTERISTICS

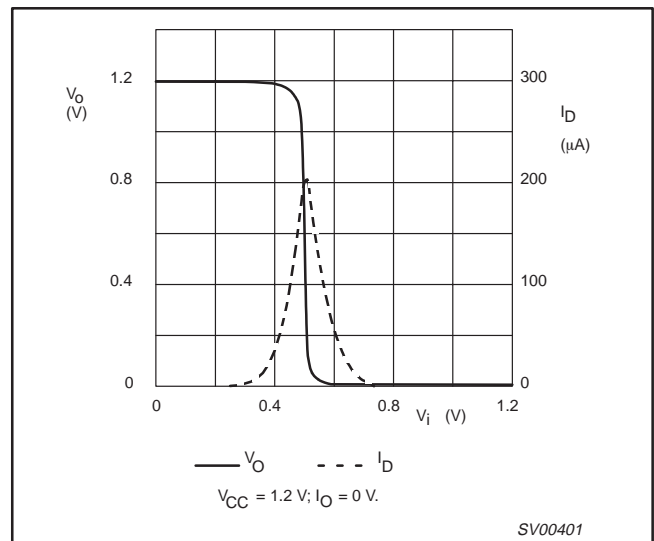

Figure 2.

# Hex inverter

# 74LVU04

## TYPICAL TRANSFER CHARACTERISTICS (Continued)

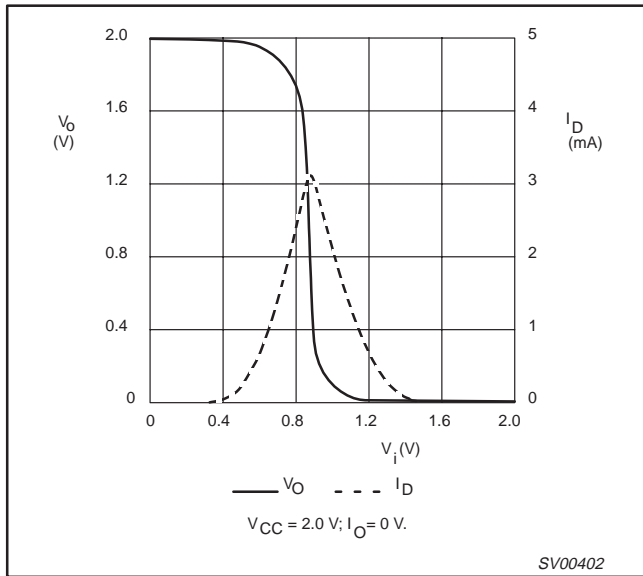

Figure 3.

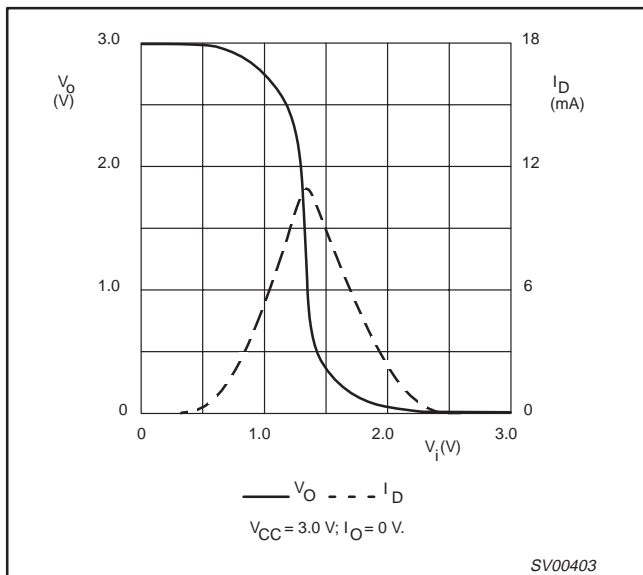

Figure 4.

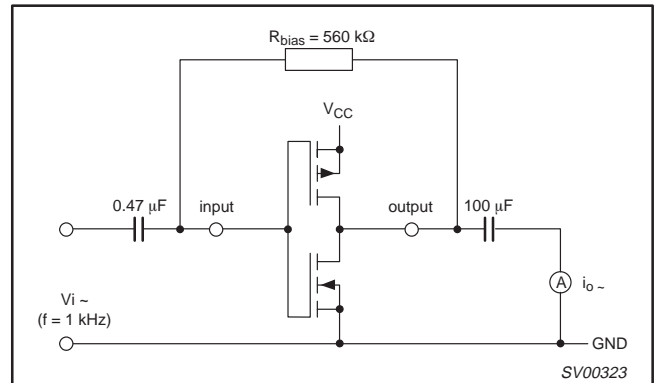

Figure 5. Test set-up for measuring forward transconductance  $g_{fs} = di_o/dv_i$  at  $v_o$  is constant (see also graph Figure 6).

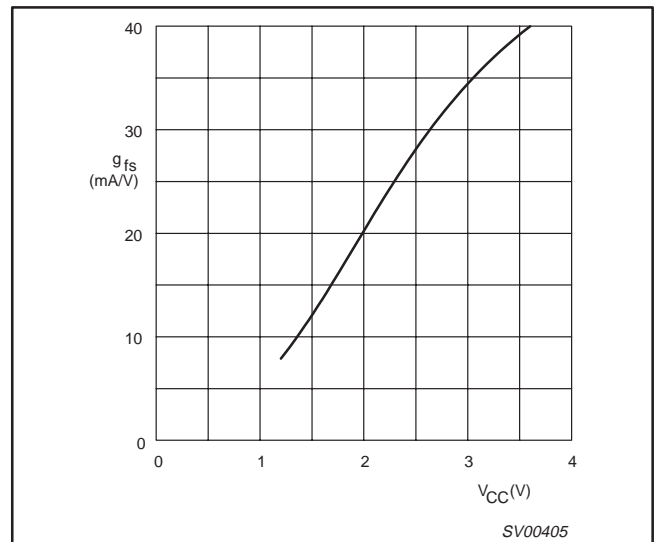

Figure 6. Typical forward transconductance  $g_{fs}$  as a function of the supply voltage  $V_{CC}$  at  $T_{amb} = 25$  °C.

# Hex inverter

# 74LVU04

## APPLICATION INFORMATION

Some applications for the 74LVU04 are:

- Linear amplifier (see Figure 7)
- In crystal oscillator designs (see Figure 8)
- Astable multivibrator (see Figure 9)

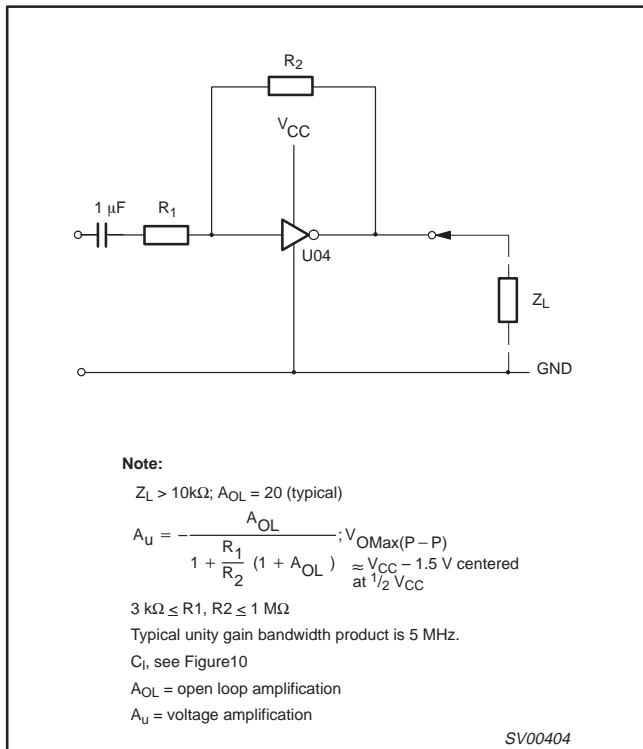

Figure 7. LVU04 used as a linear amplifier.

## EXTERNAL COMPONENTS FOR RESONATOR (f < 1 MHz)

FREQUENCY (kHz)	R <sub>1</sub> (MΩ)	R <sub>2</sub> (kΩ)	C <sub>1</sub> (pF)	C <sub>2</sub> (pF)
10 .. 15.9	2.2	220	56	20
16 .. 24.9	2.2	220	56	10
25 .. 54.9	2.2	100	56	10
55 .. 129.9	2.2	100	47	5
130 .. 199.9	2.2	47	47	5
200 .. 349.9	2.2	47	47	5
350 .. 600	2.2	47	47	5

**WHERE:**

All values given are typical and must be used as an initial set-up.

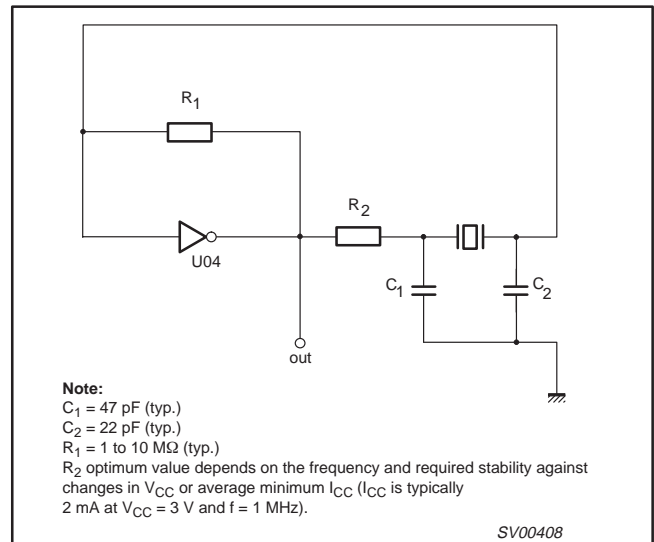

Figure 8. Crystal oscillator configuration.

## OPTIMUM VALUE FOR R<sub>2</sub>

FREQUENCY (MHz)	R <sub>2</sub> (kΩ)	Optimum
3	2.0 8.0	Minimum required $I_{CC}$ Minimum influence due to change in $V_{CC}$
6	1.0 4.7	Minimum $I_{CC}$ Minimum influence by $V_{CC}$
10	0.5 2.0	Minimum $I_{CC}$ Minimum influence by $V_{CC}$
14	0.5 1.0	Minimum $I_{CC}$ Minimum influence by $V_{CC}$
> 14	Replace $R_2$ by $C_3$ with a typical value of 35 pF	

# Hex inverter

# 74LVU04

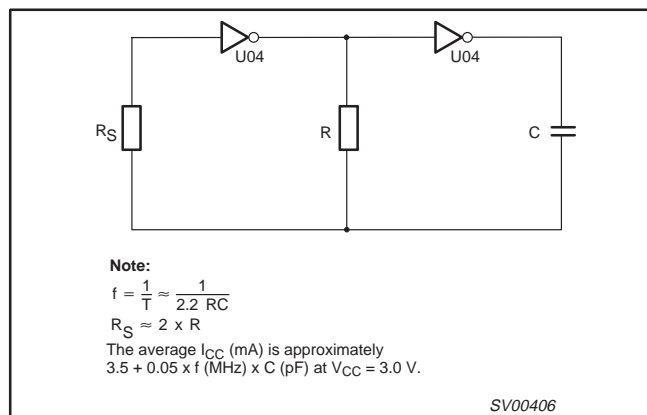

**Figure 9. LVU04 used as an astable multivibrator.**

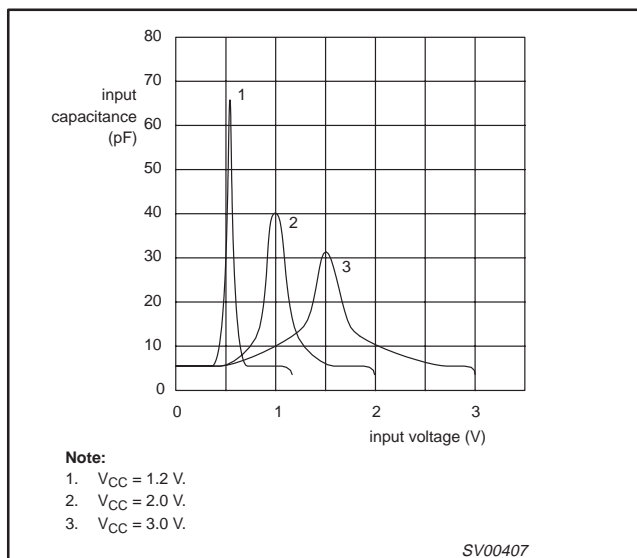

**Figure 10. Typical input capacitance as function of input voltage.**

**Note for Application Information**

All values given are typical unless otherwise specified.

Hex inverter

74LVU04

DIP14: plastic dual in-line package; 14 leads (300 mil)

SOT27-1

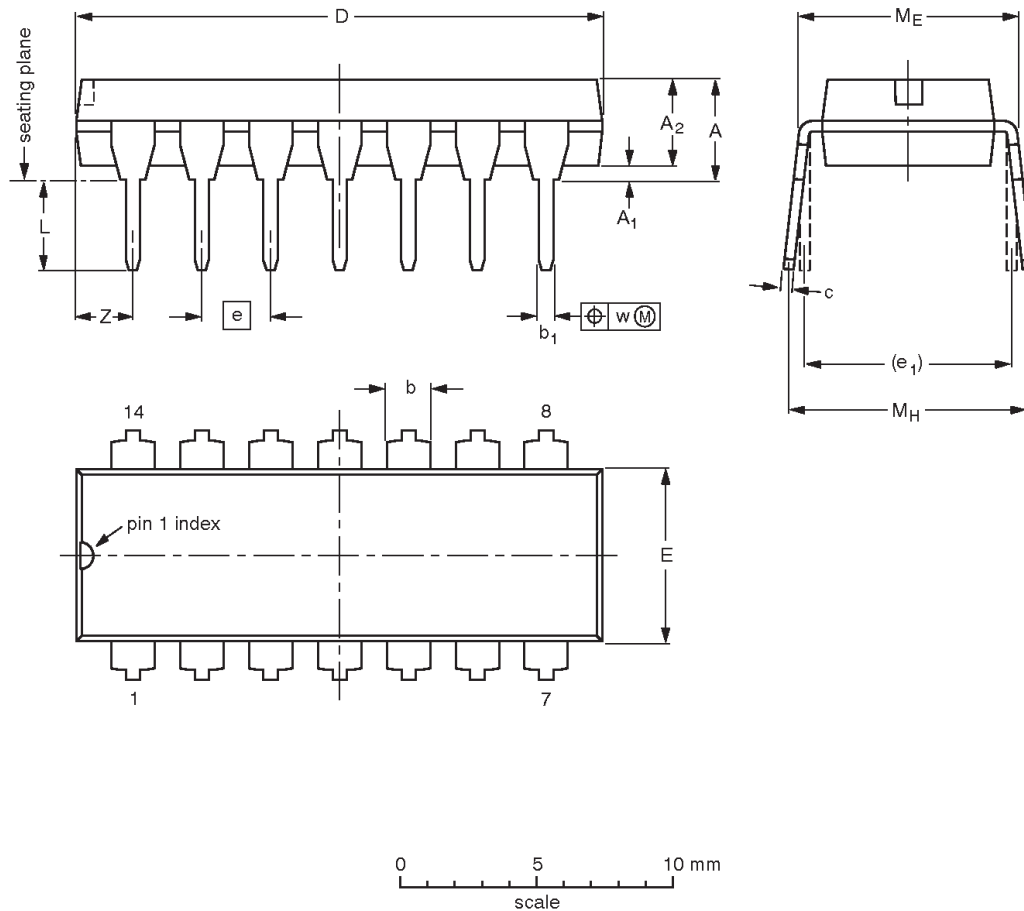

DIMENSIONS (inch dimensions are derived from the original mm dimensions)

UNIT	A max.	A <sub>1</sub> min.	A <sub>2</sub> max.	b	b <sub>1</sub>	c	D <sup>(1)</sup>	E <sup>(1)</sup>	e	e <sub>1</sub>	L	M <sub>E</sub>	M <sub>H</sub>	w	Z <sup>(1)</sup> max.
mm	4.2	0.51	3.2	1.73 1.13	0.53 0.38	0.36 0.23	19.50 18.55	6.48 6.20	2.54	7.62	3.60 3.05	8.25 7.80	10.0 8.3	0.254	2.2
inches	0.17	0.020	0.13	0.068 0.044	0.021 0.015	0.014 0.009	0.77 0.73	0.26 0.24	0.10	0.30	0.14 0.12	0.32 0.31	0.39 0.33	0.01	0.087

Note

1. Plastic or metal protrusions of 0.25 mm maximum per side are not included.

OUTLINE VERSION	REFERENCES				EUROPEAN PROJECTION	ISSUE DATE
	IEC	JEDEC	EIAJ			
SOT27-1	050G04	MO-001	SC-501-14			95-03-11 99-12-27

# Hex inverter

# 74LVU04

**SO14: plastic small outline package; 14 leads; body width 3.9 mm**

**SOT108-1**

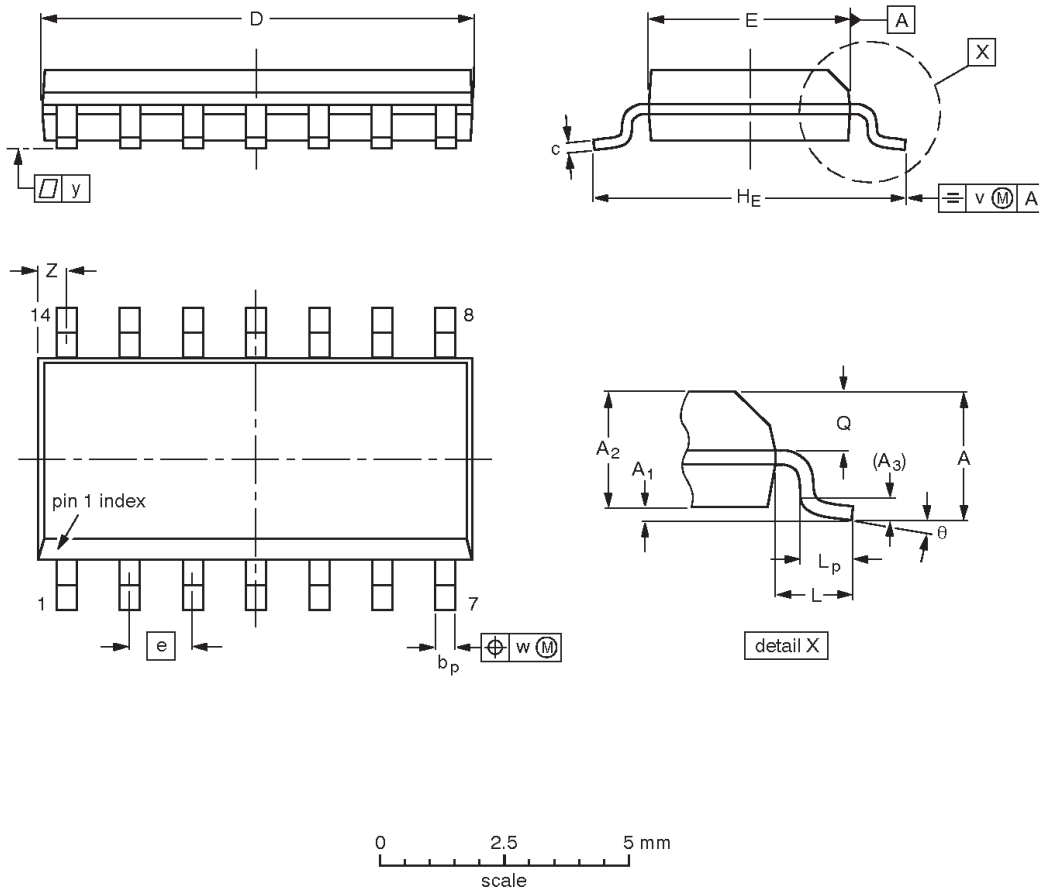

**DIMENSIONS (inch dimensions are derived from the original mm dimensions)**

UNIT	A max.	A <sub>1</sub>	A <sub>2</sub>	A <sub>3</sub>	b <sub>p</sub>	c	D <sup>(1)</sup>	E <sup>(1)</sup>	e	H <sub>E</sub>	L	L <sub>p</sub>	Q	v	w	y	z <sup>(1)</sup>	θ
mm	1.75	0.25 0.10	1.45 1.25	0.25	0.49 0.36	0.25 0.19	8.75 8.55	4.0 3.8	1.27	6.2 5.8	1.05	1.0 0.4	0.7 0.6	0.25	0.25	0.1	0.7 0.3	8° 0°
inches	0.069	0.010 0.004	0.057 0.049	0.01	0.019 0.014	0.0100 0.0075	0.35 0.34	0.16 0.15	0.050	0.244 0.228	0.041	0.039 0.016	0.028 0.024	0.01	0.01	0.004	0.028 0.012	

**Note**

1. Plastic or metal protrusions of 0.15 mm maximum per side are not included.

OUTLINE VERSION	REFERENCES				EUROPEAN PROJECTION	ISSUE DATE
	IEC	JEDEC	EIAJ			
SOT108-1	076E06	MS-012				97-05-22 99-12-27

# Hex inverter

# 74LVU04

**SSOP14:** plastic shrink small outline package; 14 leads; body width 5.3 mm

**SOT337-1**

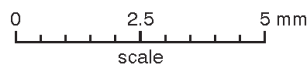
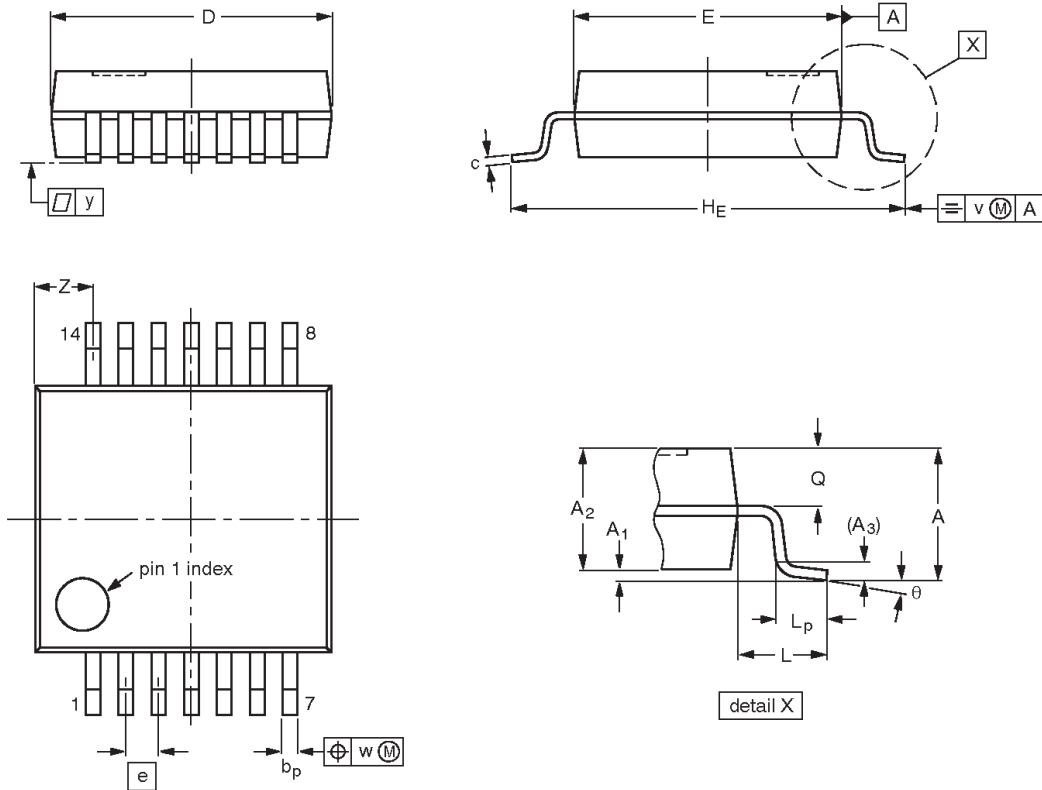

**DIMENSIONS (mm are the original dimensions)**

UNIT	A max.	A <sub>1</sub>	A <sub>2</sub>	A <sub>3</sub>	b <sub>p</sub>	c	D <sup>(1)</sup>	E <sup>(1)</sup>	e	H <sub>E</sub>	L	L <sub>p</sub>	Q	v	w	y	Z <sup>(1)</sup>	θ
mm	2.0	0.21 0.05	1.80 1.65	0.25	0.38 0.25	0.20 0.09	6.4 6.0	5.4 5.2	0.65	7.9 7.6	1.25	1.03 0.63	0.9 0.7	0.2	0.13	0.1	1.4 0.9	8° 0°

**Note**

1. Plastic or metal protrusions of 0.25 mm maximum per side are not included.

OUTLINE VERSION	REFERENCES				EUROPEAN PROJECTION	ISSUE DATE
	IEC	JEDEC	EIAJ			
SOT337-1		MO-150				96-01-18 99-12-27

# Hex inverter

# 74LVU04

**TSSOP14:** plastic thin shrink small outline package; 14 leads; body width 4.4 mm

**SOT402-1**

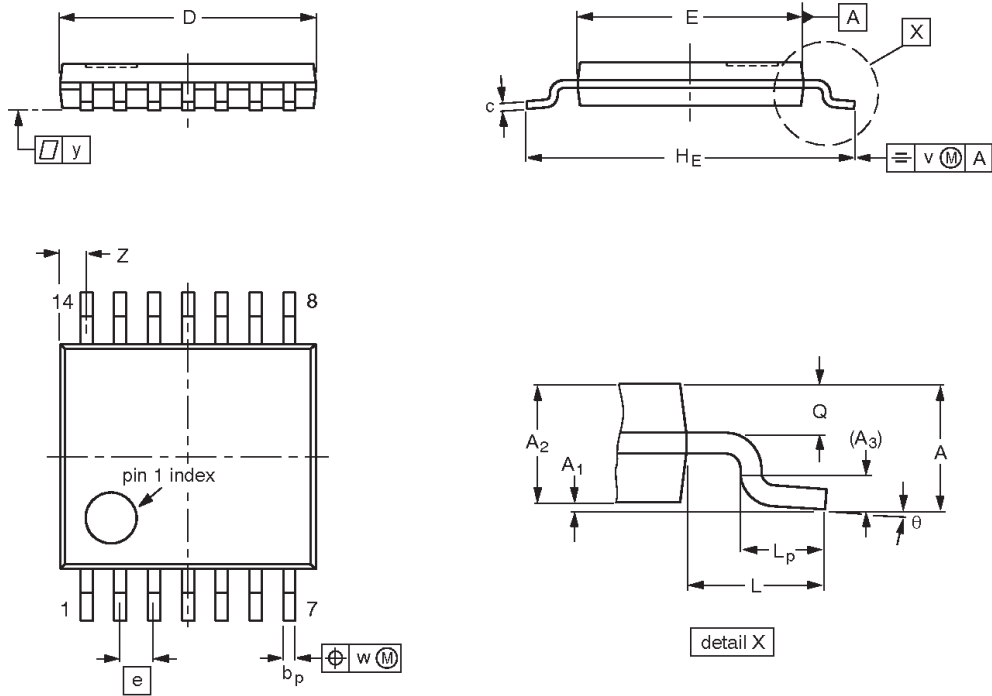

**DIMENSIONS (mm are the original dimensions)**

UNIT	A max.	A <sub>1</sub>	A <sub>2</sub>	A <sub>3</sub>	b <sub>p</sub>	c	D <sup>(1)</sup>	E <sup>(2)</sup>	e	H <sub>E</sub>	L	L <sub>p</sub>	Q	v	w	y	Z <sup>(1)</sup>	θ
mm	1.10	0.15 0.05	0.95 0.80	0.25	0.30 0.19	0.2 0.1	5.1 4.9	4.5 4.3	0.65	6.6 6.2	1.0	0.75 0.50	0.4 0.3	0.2	0.13	0.1	0.72 0.38	8° 0°

**Notes**

1. Plastic or metal protrusions of 0.15 mm maximum per side are not included.
2. Plastic interlead protrusions of 0.25 mm maximum per side are not included.

OUTLINE VERSION	REFERENCES				EUROPEAN PROJECTION	ISSUE DATE
	IEC	JEDEC	EIAJ			
SOT402-1		MO-153				-95-04-04 99-12-27

---

Hex inverter

74LVU04

---

**NOTES**

## Hex inverter

74LVU04

## Data sheet status

Data sheet status	Product status	Definition [1]
Objective specification	Development	This data sheet contains the design target or goal specifications for product development. Specification may change in any manner without notice.
Preliminary specification	Qualification	This data sheet contains preliminary data, and supplementary data will be published at a later date. Philips Semiconductors reserves the right to make changes at any time without notice in order to improve design and supply the best possible product.
Product specification	Production	This data sheet contains final specifications. Philips Semiconductors reserves the right to make changes at any time without notice in order to improve design and supply the best possible product.

[1] Please consult the most recently issued datasheet before initiating or completing a design.

## Definitions

**Short-form specification** — The data in a short-form specification is extracted from a full data sheet with the same type number and title. For detailed information see the relevant data sheet or data handbook.

**Limiting values definition** — Limiting values given are in accordance with the Absolute Maximum Rating System (IEC 134). Stress above one or more of the limiting values may cause permanent damage to the device. These are stress ratings only and operation of the device at these or at any other conditions above those given in the Characteristics sections of the specification is not implied. Exposure to limiting values for extended periods may affect device reliability.

**Application information** — Applications that are described herein for any of these products are for illustrative purposes only. Philips Semiconductors make no representation or warranty that such applications will be suitable for the specified use without further testing or modification.

## Disclaimers

**Life support** — These products are not designed for use in life support appliances, devices or systems where malfunction of these products can reasonably be expected to result in personal injury. Philips Semiconductors customers using or selling these products for use in such applications do so at their own risk and agree to fully indemnify Philips Semiconductors for any damages resulting from such application.

**Right to make changes** — Philips Semiconductors reserves the right to make changes, without notice, in the products, including circuits, standard cells, and/or software, described or contained herein in order to improve design and/or performance. Philips Semiconductors assumes no responsibility or liability for the use of any of these products, conveys no license or title under any patent, copyright, or mask work right to these products, and makes no representations or warranties that these products are free from patent, copyright, or mask work right infringement, unless otherwise specified.

Philips Semiconductors  
811 East Arques Avenue  
P.O. Box 3409  
Sunnyvale, California 94088-3409  
Telephone 800-234-7381

© Copyright Philips Electronics North America Corporation 2001  
All rights reserved. Printed in U.S.A.

Date of release: 01-01

Document order number:

9397 750 07912

*Let's make things better.*



LittleDiode supplies new, hard to find or obsolete electronic components and semiconductors all over the world.

With over two million different components listed you are sure to find the part you need.

Feel free to visit us today at our online store:

**[LittleDiode.com](http://LittleDiode.com)**

Looking forward to providing you with the best possible service.