

AC16DGM to AC16FGM

16 A MOLD TRIAC

PACKAGE DIMENSIONS in millimeters

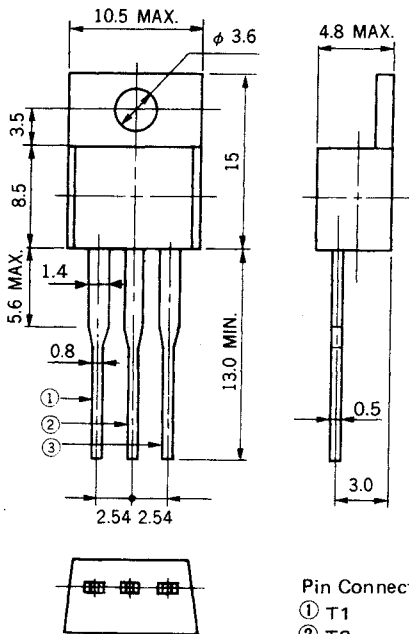

Pin Connection
 ① T1
 ② T2
 ③ Gate

The AC16DGM to AC16FGM are all diffused mold type TRIAC granted RMS On-state current 16 Amps, with rated voltages up to 600 Volts.

FEATURES

- 150 A Surge Current
- TO-220AB mold package
- Low cost

APPLICATIONS

Motor speed control,
 Lamp dimmer, Temperature controllers,
 Various solid state switches, etc.

MAXIMUM RATINGS

ITEM	SYMBOL	AC16DGM	AC16EGM	AC16FGM	UNIT	NOTE
Repetitive Peak-off Voltage	V_{DRM}	400	500	600	V	
Non-Repetitive Peak-off Voltage	V_{DSM}	500	600	700	V	
RMS On-state Current	$I_T(RMS)$	16 ($T_c = 100^\circ C$)			A	See Fig. 11, 12
Surge On-state Current	I_{TSM}	150 (50 Hz Non-repetitive)			A	See Fig. 2
Fusing Current	$\int i_T^2 dt$	100			A ² S	
Peak Gate Power Dissipation	P_{GM}	5			W	
Average Gate Power Dissipation	$P_{G(AV)}$	0.5			W	
Peak Gate Current	I_{GM}	±3			A	
Junction Temperature	T_j	-40 to +125			°C	
Storage Temperature	T_{stg}	-40 to +125			°C	

ELECTRICAL CHARACTERISTICS (T_j = 25 °C)

ITEM	SYMBOL	TEST CONDITIONS	MIN.	TYP.	MAX.	UNIT	NOTE	
Peak Off-State Current	I _{DRM}	V _{DM} = V _{DRM}	T _j = 25 °C	-	-	0.1	mA	-
			T = 125 °C	-	-	2		
On-State Voltage	V _{TM}	I _{TM} = 25 A	-	-	1.4	V	See Fig. 1	
Critical Rate of Rise of Off-state Voltage	dv/dt	T _j = 125 °C V _{DM} = $\frac{2}{3}$ V _{DRM}	-	100	-	V/μs	-	
DC Gate Trigger Current	I _{GT}	V _{DM} = 12 V R _L = 30 Ω	T ₂ +, G+	-	-	30	mA	See Fig. 3, 4, 5, 7
			T ₂ -, G+	-	-	80		
			T ₂ -, G-	-	-	30		
			T ₂ +, G-	-	-	30		
DC Gate Trigger Voltage	V _{GT}	V _{DM} = 12 V R _L = 30 Ω	T ₂ +, G+	-	-	1.5	V	See Fig. 3, 4, 6, 8
			T ₂ -, G+	-	-	2.0		
			T ₂ -, G-	-	-	1.5		
			T ₂ +, G-	-	-	1.5		
Gate Non-Trigger Voltage	V _{GD}	T _j = 125 °C V _{DM} = $\frac{1}{2}$ V _{DRM}	0.3	-	-	V	-	
DC Holding Current	I _H	V _D = 24 V	-	30	-	mA		
Critical Rate of Rise of Commutating Off-State Voltage	(dv/dt) _c	T _j = 125 °C, I _{TM} = 22 A (di _T /dt) _c = -8 A/ms V _D = 400 V	10	-	-	V/μs		
Thermal Resistance	R _{th(j-c)}	Junction-to-Case	-	-	1.5	°C/W	See Fig. 13	

Trigger Mode & Test Circuit

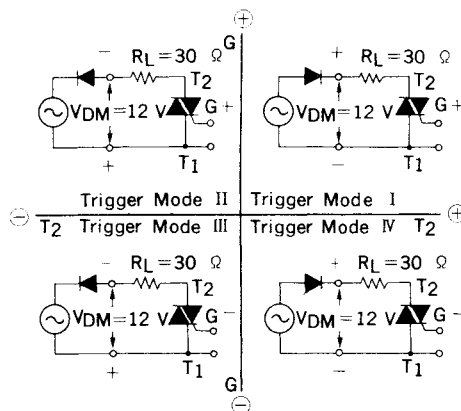

Fig. 1 $i_T - v_T$ CHARACTERISTIC

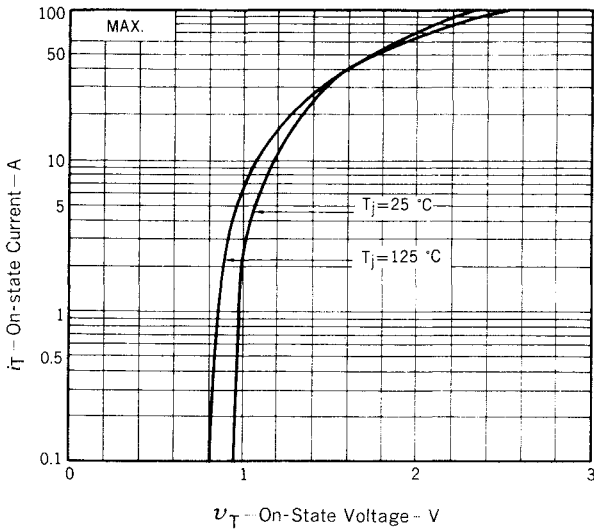

Fig. 2 I_{TSM} RATING

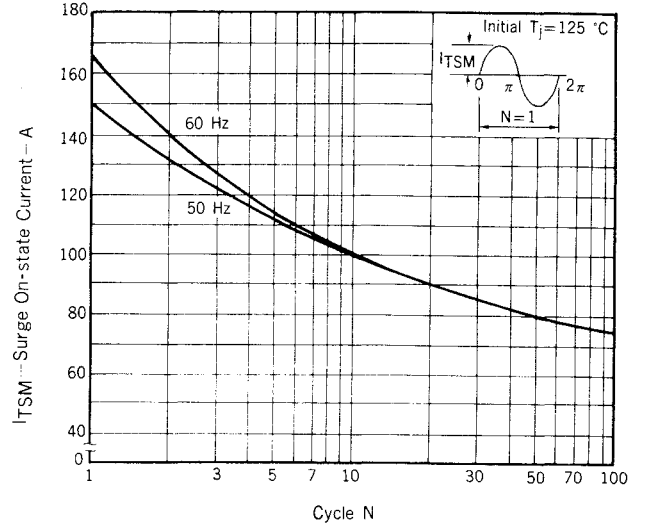

Fig. 3 $V_G - I_G$ RATING

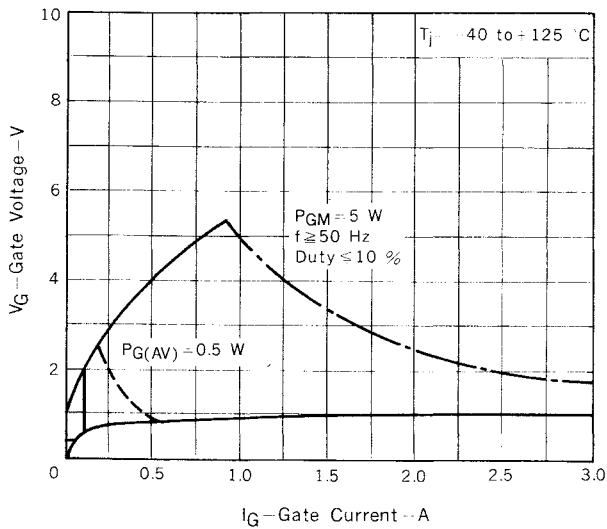

Fig. 4 $V_{GT} - I_{GT}$ CHARACTERISTIC

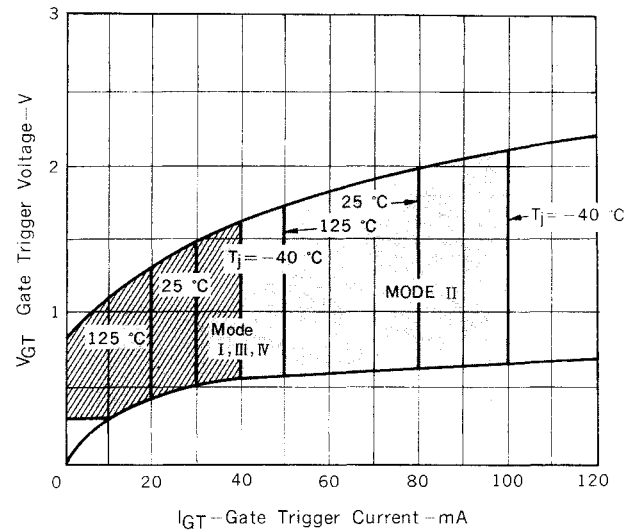

Fig. 5 $I_{GT} - T_a$ TYPICAL DISTRIBUTION

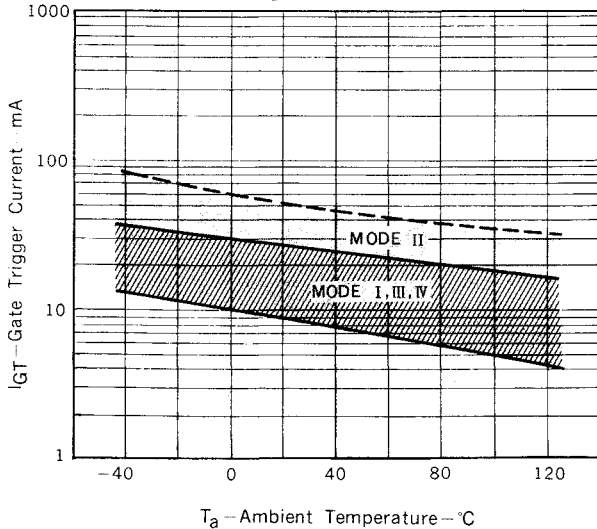

Fig. 6 $V_{GT} - T_a$ TYPICAL DISTRIBUTION

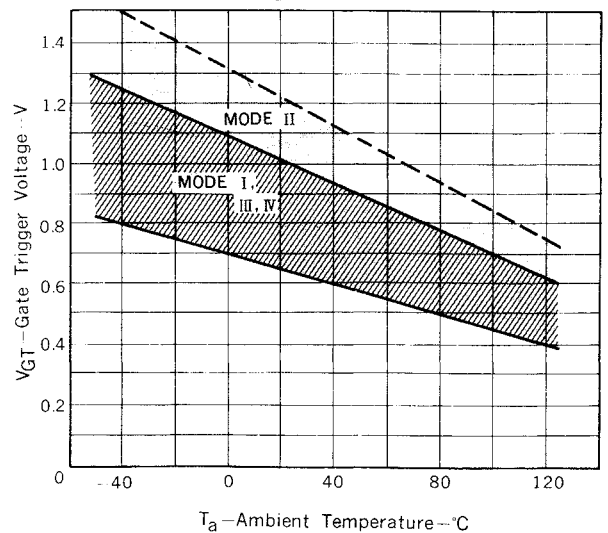

Fig. 7 $i_{GT} - \tau$ TYPICAL DISTRIBUTION

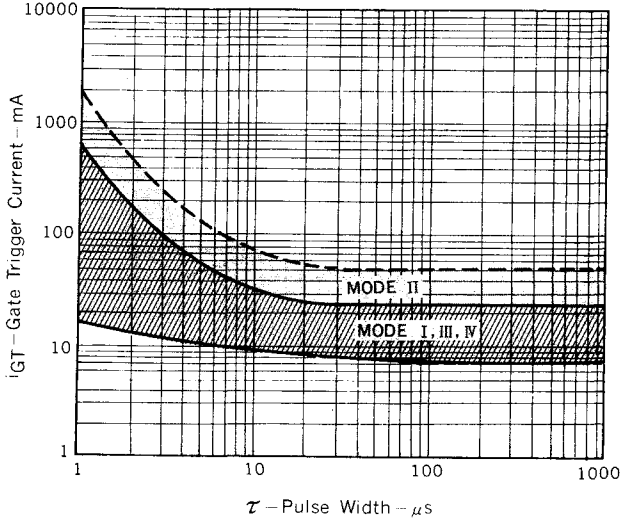

Fig. 8 $v_{GT} - \tau$ TYPICAL DISTRIBUTION

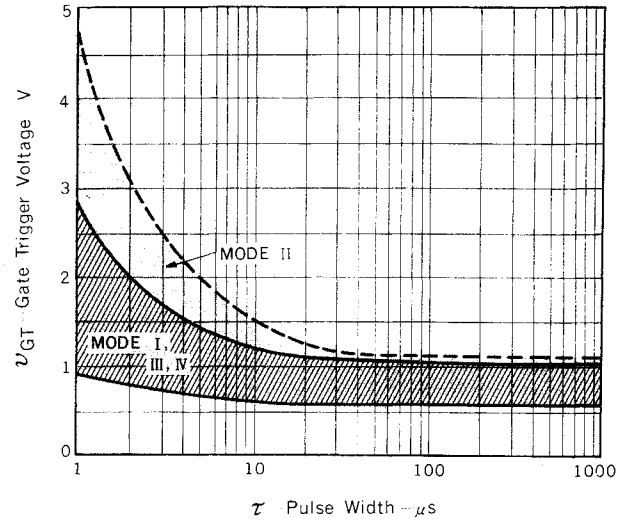

Fig. 9 $I_H - T_a$ CHARACTERISTIC

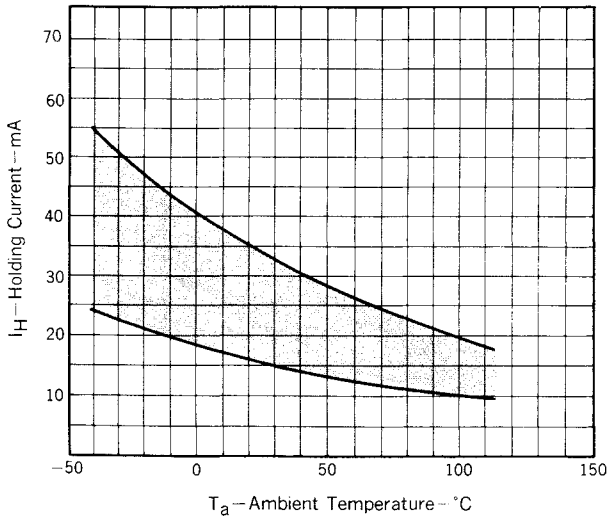

Fig. 10 $P_{T(AV)} - I_{T(RMS)}$ CHARACTERISTIC

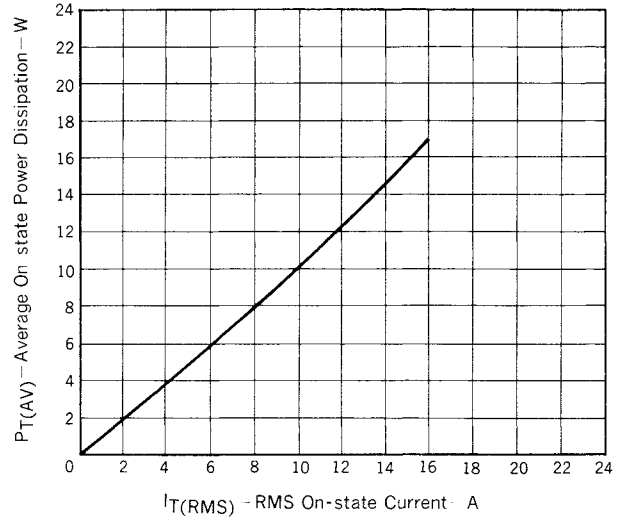

Fig. 11 $T_c - I_{T(RMS)}$ RATING

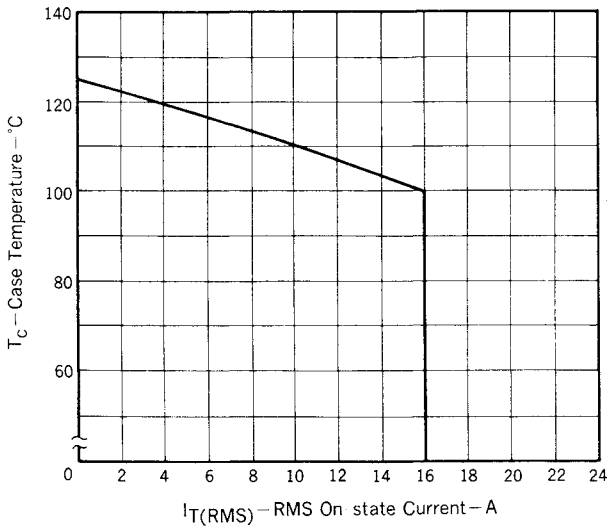

Fig. 12 $T_a - I_{T(RMS)}$ RATING

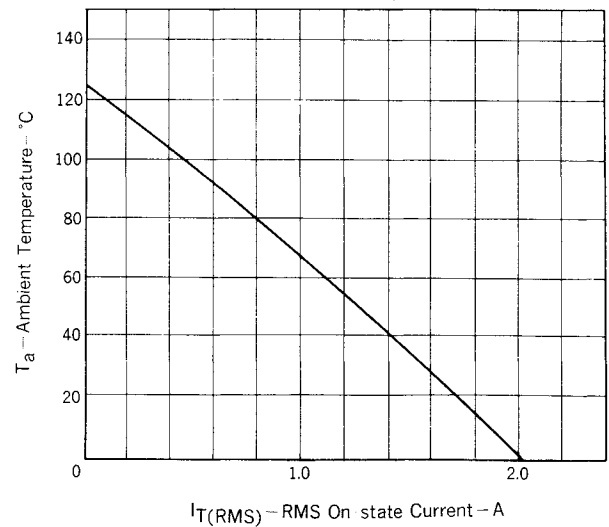
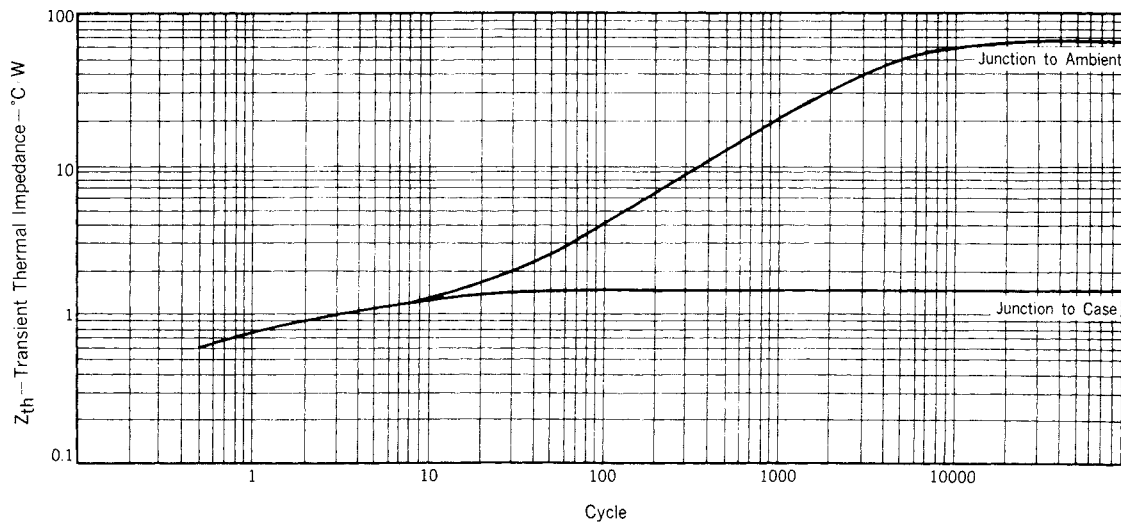

Fig. 13 Z_{th} CHARACTERISTIC



NEC Corporation

INTERNATIONAL ELECTRON DEVICES DIV.
SUMITOMO MITA Building, 37-8,
Shiba Gochome, Minato-ku, Tokyo 108, Japan
Tel: Tokyo 456-3111
Telex Address: NECTOK J22686
Cable Address: NEC TOKYO

SC-1036
OCT.-1-85M
Printed in Japan



LittleDiode supplies new, hard to find or obsolete electronic components and semiconductors all over the world.

With over two million different components listed you are sure to find the part you need.

Feel free to visit us today at our online store:

LittleDiode.com

Looking forward to providing you with the best possible service.