



## ASD™ AC Switch Family

## AC LINE SWITCH

### MAIN APPLICATIONS

- AC on-off static switching in appliance & industrial control systems
- Drive of low power high inductive or resistive loads like
  - relay, valve, solenoid, dispenser
  - pump, fan, micro-motor
  - low power lamp bulb, door lock

### FEATURES

- Blocking voltage :  $V_{DRM} / V_{RRM} = 500V$
- Clamping voltage :  $V_{CL} = 600 V$
- Nominal current :  $I_{T(RMS)} = 0.2 A$
- Gate triggering current :  $I_{GT} < 5 mA$
- Switch integrated driver
- Triggering current is sourced by the gate
- SO-8 package:
  - drive reference COM connected to 2 cooling pins
  - 3.5 mm creepage distance from pin OUT to other pins

### BENEFITS

- Needs no external overvoltage protection
- Enables equipment to meet IEC61000-4-5 & IEC 335-1
- Reduces component count by up to 80 %
- Interfaces directly with a microcontroller
- Eliminates any stressing gate kick back on microcontroller
- Allows straightforward connection of several ACS™ on same cooling pad.

### DESCRIPTION

The ACS102 belongs to the AC line switch family built around the ASD™ concept. This high performance device is able to control an up to 0.3 A load device.

The ACS™ switch embeds a high voltage clamping structure to absorb the inductive turn off energy and a gate level shifter driver to separate the digital controller from the main switch. It is triggered with a negative gate current flowing out of the gate pin.

For further technical information, please refer to AN1172 application note.

ASD and ACS are a trademarks of STMicroelectronics.

October 2001 - Ed: 7B

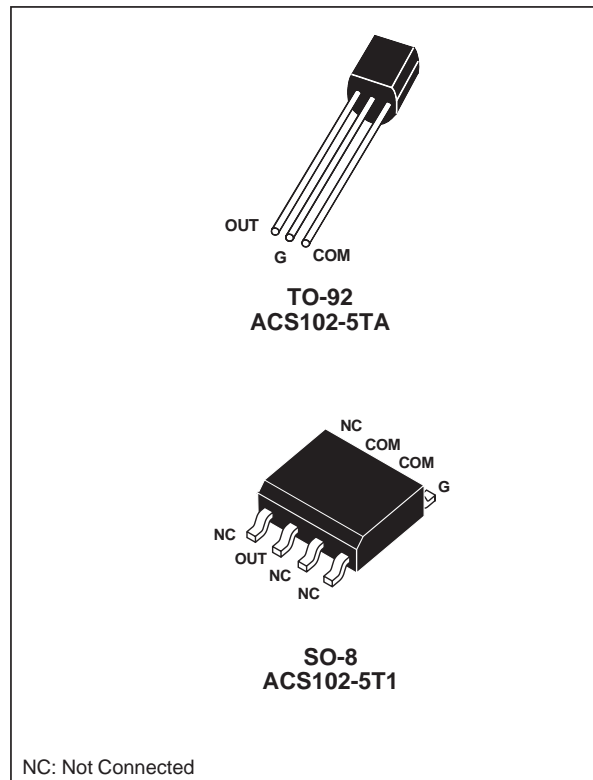

### FUNCTIONAL DIAGRAM

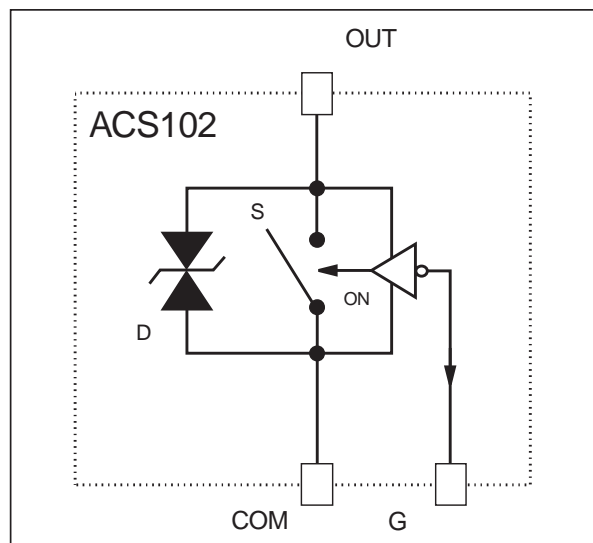

## ACS102-5Tx

### ABSOLUTE RATINGS (limiting values)

| Symbol              | Parameter   |            | Value                     | Unit          |                  |
|---------------------|---|------------|---------------------------|---------------|------------------|
| $V_{DRM} / V_{RRM}$ | Repetitive peak off-state voltage   |            | $T_j = 125\text{ °C}$     | 500           | V                |
| $I_{T(RMS)}$        | RMS on-state current full cycle sine wave 50 to 60 Hz   | TO-92      | $T_{amb} = 100\text{ °C}$ | 0.2           | A                |
|                     |   | SO-8       | $T_{amb} = 100\text{ °C}$ | 0.2           | A                |
| $I_{TSM}$           | Non repetitive surge peak on-state current<br>$T_j$ initial = 25°C, full cycle sine wave              | F = 50 Hz  |                           | 7.3           | A                |
|                     |   | F = 60 Hz  |                           | 8             | A                |
| dI/dt               | Critical rate of repetitive rise of on-state current<br>$I_G = 10\text{mA}$ with $t_r = 100\text{ns}$ | F = 120 Hz |                           | 20            | A/ $\mu\text{s}$ |
| $V_{PP}$            | Non repetitive line peak pulse voltage  | note 1     |                           | 2             | kV               |
| $T_{stg}$           | Storage temperature range   |            |                           | - 40 to + 150 | °C               |
| $T_j$               | Operating junction temperature range  |            |                           | - 30 to + 125 | °C               |
| TI                  | Maximum lead temperature for soldering during 10s   |            |                           | 260           | °C               |

Note 1: according to test described by IEC61000-4-5 standard & Figure 3.

### SWITCH GATE CHARACTERISTICS (maximum values)

| Symbol      | Parameter   | Value | Unit |
|-------------|---|-------|------|
| $P_{G(AV)}$ | Average gate power dissipation                      | 0.1   | W    |
| $I_{GM}$    | Peak gate current ( $t_p = 20\mu\text{s}$ )         | 1     | A    |
| $V_{GM}$    | Peak positive gate voltage (respect to the pin COM) | 5     | V    |

### THERMAL RESISTANCES

| Symbol        | Parameter   |        | Value | Unit |      |
|---------------|---|--------|-------|------|------|
| $R_{th(j-a)}$ | Junction to ambient                                 | TO-92  | 150   | °C/W |      |
|               |   | SO-8 * | 150   | °C/W |      |
| $R_{th(j-l)}$ | Junction to leads for full AC line cycle conduction |        | TO-92 | 60   | °C/W |

\* with 40mm<sup>2</sup> copper (ex: 35 $\mu\text{m}$ ) surface under "com" pins

### ELECTRICAL CHARACTERISTICS

For either positive or negative polarity of pin OUT voltage respect to pin COM voltage excepted note 3\*.

| Symbol                            | Test Conditions   |                    | Values | Unit |                  |
|-----------------------------------|---|--------------------|--------|------|------------------|
| $I_{GT}$                          | $V_{OUT}=12\text{V}$ $R_L=140\Omega$                    | $T_j=25\text{°C}$  | MAX    | 5    | mA               |
| $V_{GT}$                          | $V_{OUT}=12\text{V}$ $R_L=140\Omega$                    | $T_j=25\text{°C}$  | MAX    | 0.9  | V                |
| $V_{GD}$                          | $V_{OUT}=V_{DRM}$ $R_L=3.3\text{k}\Omega$               | $T_j=125\text{°C}$ | MIN    | 0.15 | V                |
| $I_H$                             | $I_{OUT}=100\text{mA}$ gate open                        | $T_j=25\text{°C}$  | TYP    | 20   | mA               |
|                                   |   |                    | MAX    | tbd  |                  |
| $I_L$                             | $I_G=20\text{mA}$                                       | $T_j=25\text{°C}$  | TYP    | 25   | mA               |
|                                   |   |                    | MAX    | tbd  |                  |
| $V_{TM}$                          | $I_{OUT}=0.3\text{A}$ $t_p=380\mu\text{s}$              | $T_j=25\text{°C}$  | MAX    | 1.2  | V                |
| $I_{DRM}$<br>$I_{RRM}$            | $V_{OUT}=V_{DRM}$<br>$V_{OUT}=V_{RRM}$                  | $T_j=25\text{°C}$  | MAX    | 2    | $\mu\text{A}$    |
|                                   |   | $T_j=125\text{°C}$ | MAX    | 200  |                  |
| dV/dt                             | $V_{OUT}=400\text{V}$ gate open                         | $T_j=110\text{°C}$ | MIN    | 300  | V/ $\mu\text{s}$ |
| (dI/dt) <sub>c</sub><br>*(Note 3) | (dV/dt) <sub>c</sub> = 5V/ $\mu\text{s}$ $I_{OUT} > 0$  | $T_j=110\text{°C}$ | MIN    | 0.1  | A/ms             |
|                                   | (dV/dt) <sub>c</sub> = 10V/ $\mu\text{s}$ $I_{OUT} < 0$ |                    |        | 0.15 |                  |
| $V_{CL}$                          | $I_{CL}=1\text{mA}$ $t_p=1\text{ms}$                    | $T_j=25\text{°C}$  | TYP    | 600  | V                |

tbd = to be defined

**AC LINE SWITCH BASIC APPLICATION**

The ACS102 device is well adapted to washing machines, dish washers, tumble driers, refrigerators, water heaters, and cookware. It has been designed especially to switch on & off low power loads such as solenoids, valves, relays, dispensers, micro-motors, pumps, fans, door locks, and low power lamps bulbs.

- Pin COM : Common drive reference, to connect to the power line neutral
- Pin G : Switch Gate input to connect to the digital controller through a resistor
- Pin OUT : Switch Output, to connect to the load

This ACS™ switch is triggered with a negative gate current flowing out of the gate pin G. It can be driven directly by the digital controller through a resistor as shown on the typical application diagram. No protection device are required between the gate and COM terminals. The SO-8 version allows to connect several ACS102 devices on the same cooling PCB pad which is the COM pin.

In appliance systems, the ACS102 switch intends to drive low power loads in full cycle ON / OFF mode. The turn off commutation characteristics of these loads are described in Table 1. Thanks to its thermal and turn-off commutation characteristics, the ACS102 switch drives a load, such as door lock, lamp, relay, valve and micro motor, up to 0.2A without any turn-off aid circuit. Switching off the ACS within one full AC line cycle will extend its current up to 0.3 A.

**Table 1:** Low power load turn off commutation requirement (230V AC applications).

| LOAD                                    | Load IRMS current (A) | POWER FACTOR | (di/dt)c (A/ms) | (dV/dt)c (V/μs) | TURN-OFF DELAY (ms) |
|---|-----------------------|--------------|-----------------|-----------------|---------------------|
| Door lock, lamp                         | < 0.2                 | 1            | < 0.1           | < 0.15          | < 10                |
| Relay Valve<br>Dispenser<br>Micro-motor | < 0.2                 | > 0.7        | < 0.1           | < 5             | < 10                |
| Pump Fan                                | < 0.3                 | > 0.2        | < 0.15          | < 10            | < 20                |

**TYPICAL APPLICATION DIAGRAM**

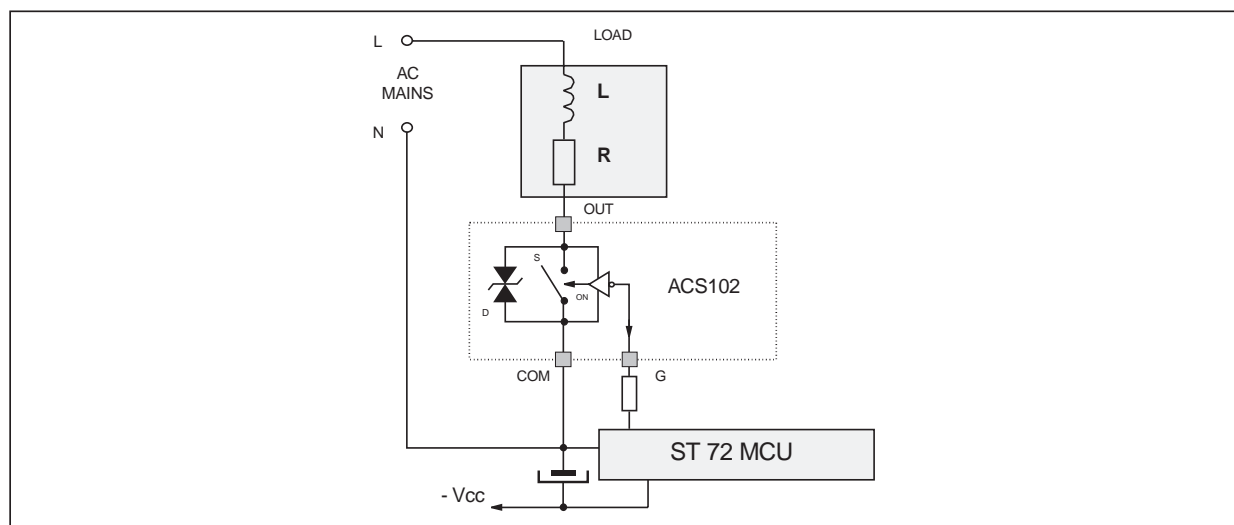

**HIGH INDUCTIVE SWITCH-OFF OPERATION**

At the end of the last conduction half-cycle, the load current reaches the holding current level  $I_H$ , and the ACS™ switch turns off. Because of the inductance  $L$  of the load, the current flows through the avalanche diode  $D$  and decreases linearly to zero. During this time, the voltage across the switch is limited to the clamping voltage  $V_{CL}$ .

The energy stored in the inductance of the load depends on the holding current  $I_H$  and the inductance (up to 10 H); it can reach about 20 mJ and is dissipated in the clamping diode section. The ACS™ switch sustains the turn off energy, because its clamping section is designed for that purpose.

**Fig. 1:** Turn-off operation of the ACS102 switch with an electro valve: waveform of the gate current  $I_G$ , pin OUT current  $I_{OUT}$  & voltage  $V_{OUT}$ .

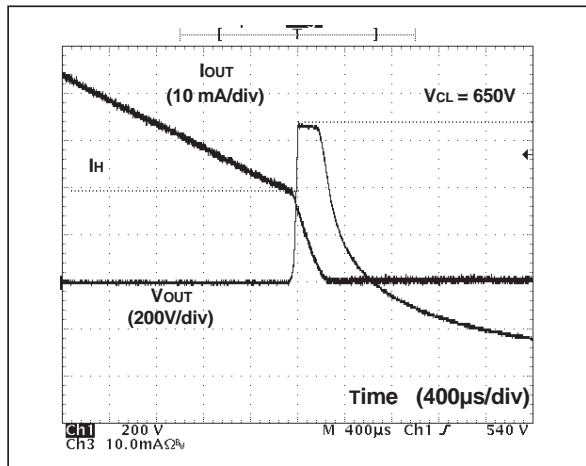

**Fig. 2:** ACS102 switch static characteristic.

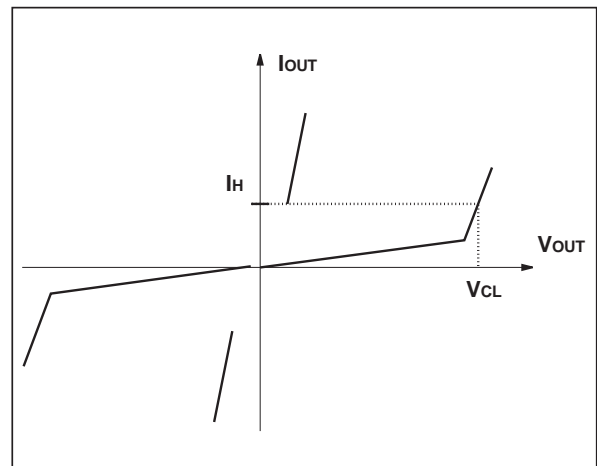

**AC LINE TRANSIENT VOLTAGE RUGGEDNESS**

The ACS102 switch is able to withstand safely the AC line transient voltages either by clamping the low energy spikes or by breaking over under high energy shocks.

The test circuit of the figure 3 is representative of the final ACS™ application and is also used to stress the ACS™ switch according to the IEC61000-4-5 standard conditions. Thanks to the load, the ACS™ switch withstands the voltage spikes up to 2 kV above the peak line voltage. It will break over safely even on resistive load where the turn on current rate of increase is high as shown on figure 4. Such non repetitive test can be done 10 times on each AC line voltage polarity.

**Fig. 3:** Overvoltage ruggedness test circuit for resistive and inductive loads according to IEC61000-4-5 standard.  $R = 150\Omega$ ,  $L = 5\mu H$ ,  $V_{PP} = 2kV$ .

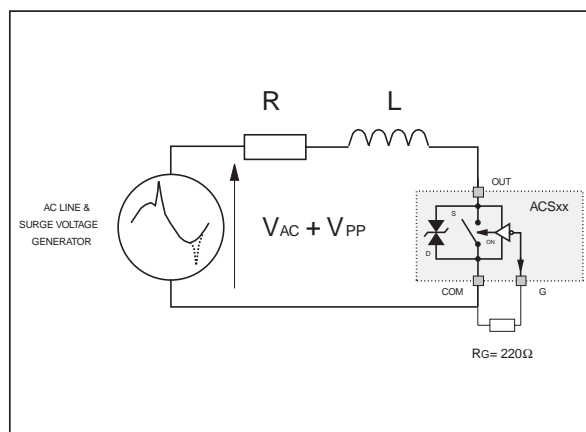

**Fig. 4:** Current and Voltage of the ACS™ during IEC61000-4-5 standard test with  $R = 150\Omega$ ,  $L = 5\mu H$  &  $V_{PP} = 2kV$ .

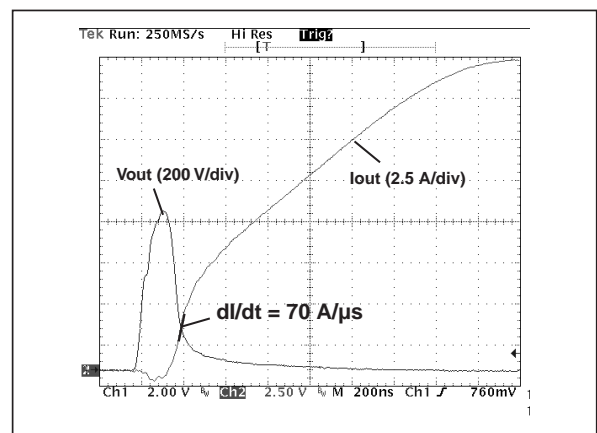

**Fig. 5:** Maximum power dissipation versus RMS on-state current.

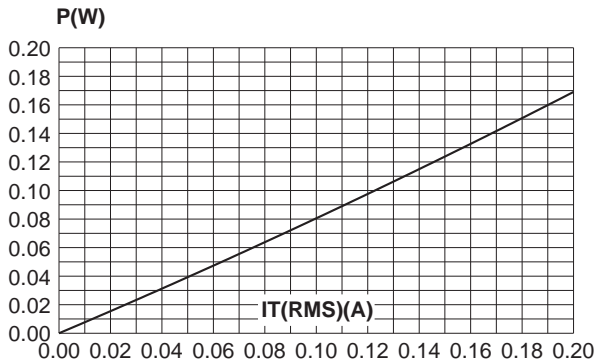

**Fig. 6:** RMS on-state current versus ambient temperature.

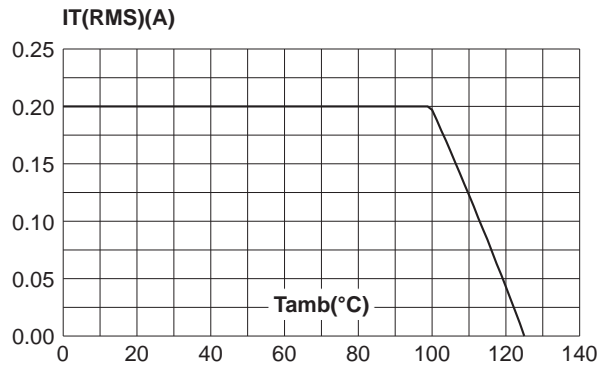

**Fig. 7-1:** Relative variation of thermal impedance junction to ambient versus pulse duration (ACS102-5TA) (TO-92).

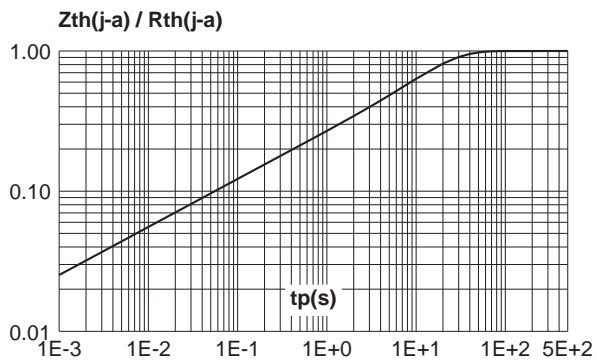

**Fig. 7-2:** Relative variation of thermal impedance junction to ambient versus pulse duration (printed circuit board FR4, e(Cu) = 35µm, S(Cu) = 40mm<sup>2</sup> under “com” pins) (ACS102-5T1) (SO-8).

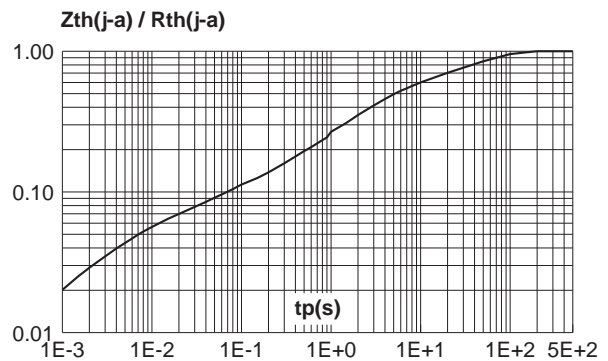

**Fig. 8:** Relative variation of gate trigger current versus junction temperature.

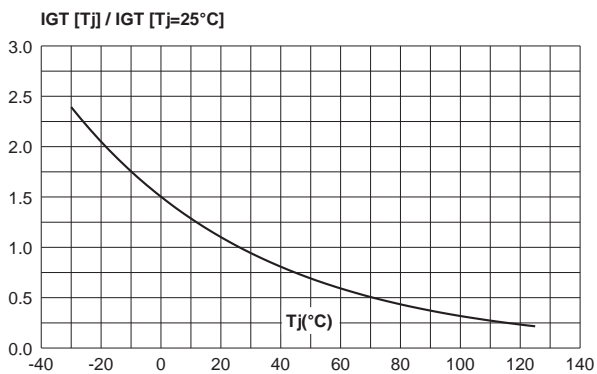

**Fig. 9:** Relative variation of holding and latching current versus junction temperature.

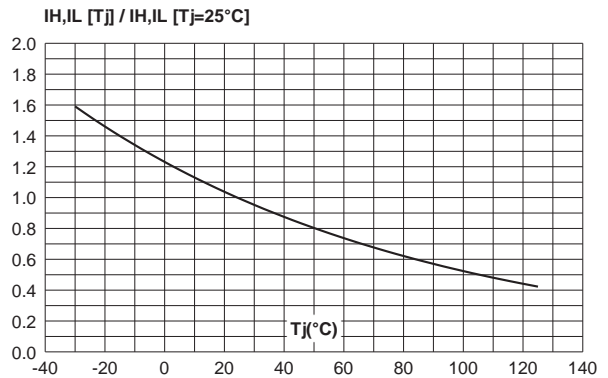

**Fig. 10:** Surge peak on-state current versus number of cycles.

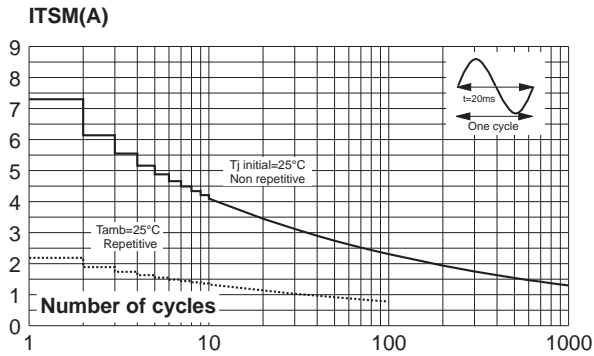

**Fig. 11:** Non-repetitive surge peak on-state current for a sinusoidal pulse with width  $t_p < 10ms$ , and corresponding value of  $I^2t$ .

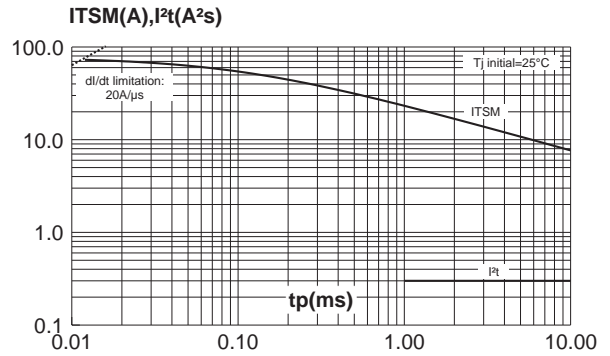

**Fig. 12:** On-state characteristics (maximum values).

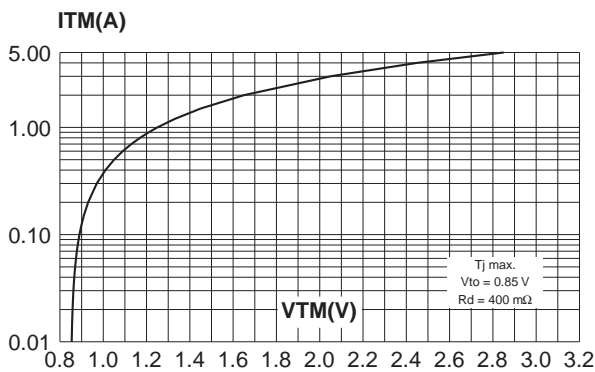

**Fig. 13:** Thermal resistance junction to ambient versus copper surface under tab (Epoxy printed circuit board FR4, copper thickness under "com" pins: 35μm) (ACS102-5T1).

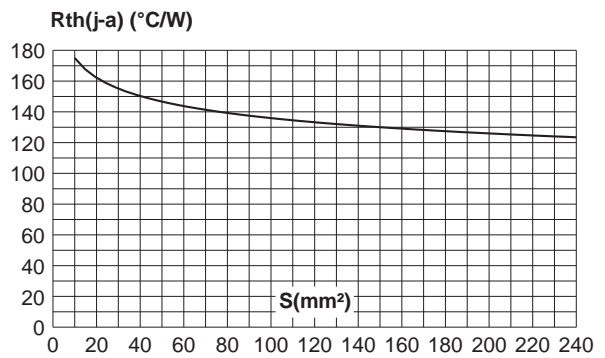

**Fig. 14:** Relative variation of critical  $(di/dt)_c$  versus junction temperature (ACS102-5T1).

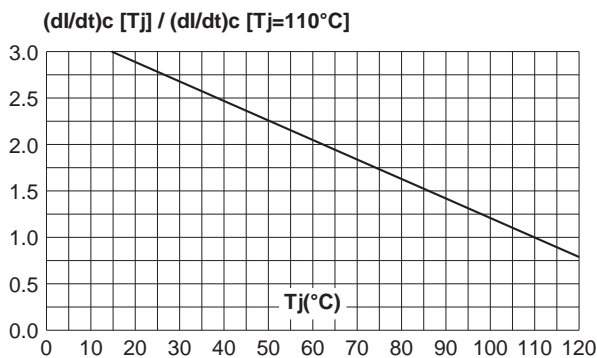

ORDERING INFORMATION

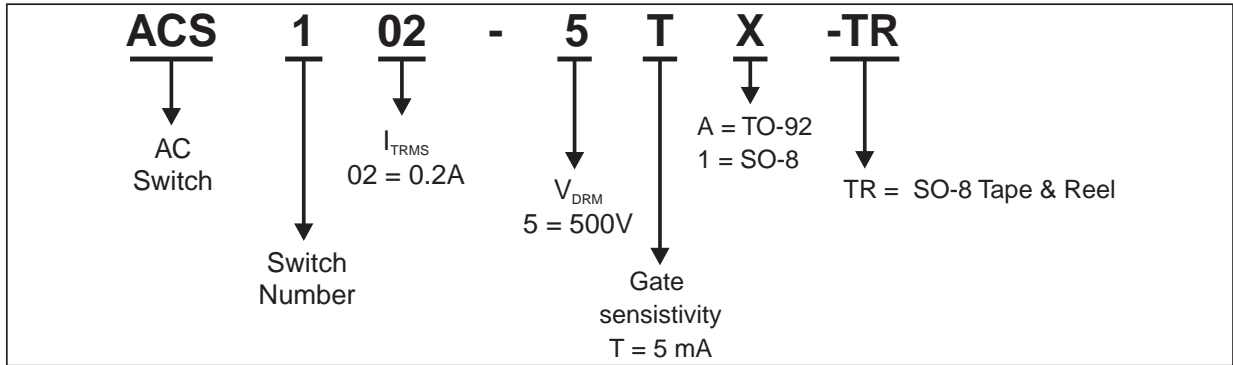

PACKAGE OUTLINE MECHANICAL DATA

SO-8

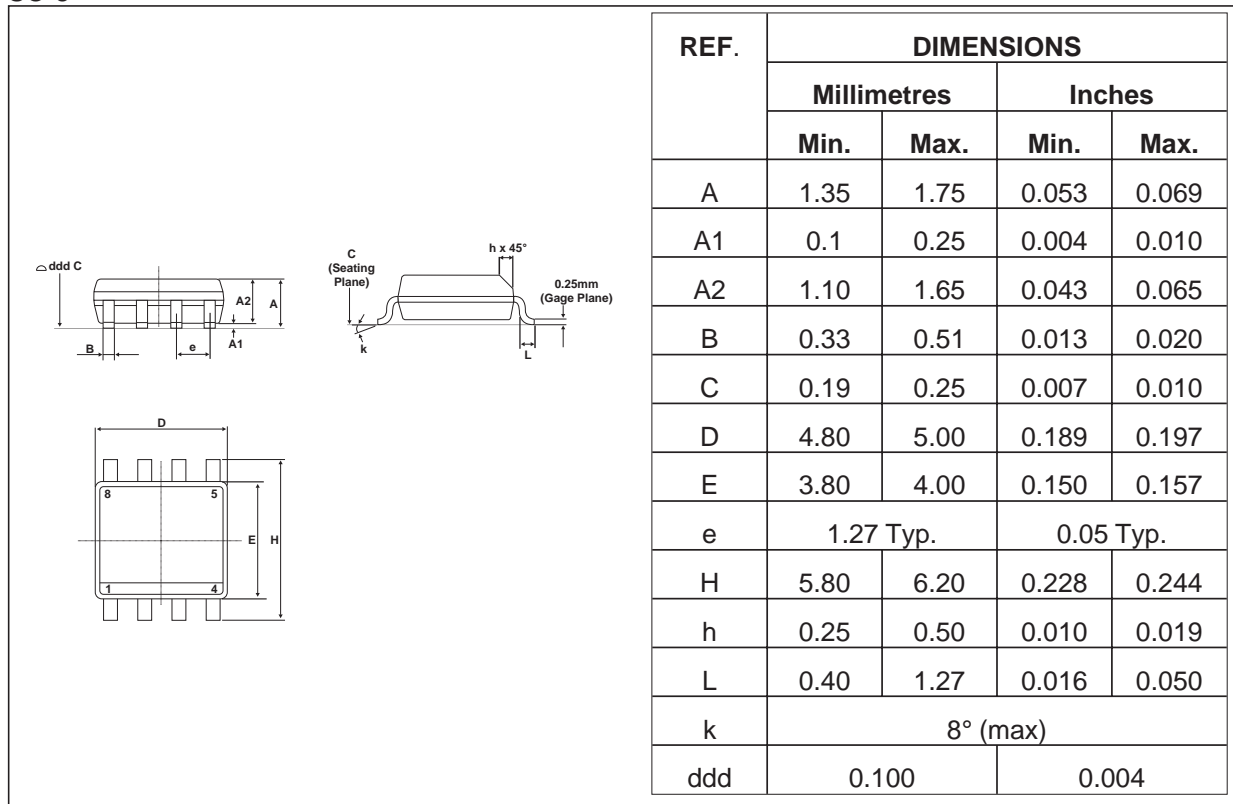

PACKAGE FOOT PRINT

SO-8

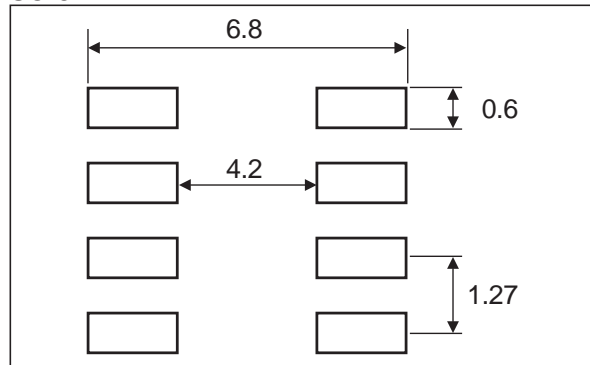

# ACS102-5Tx

## PACKAGE OUTLINE MECHANICAL DATA TO-92 (Plastic)

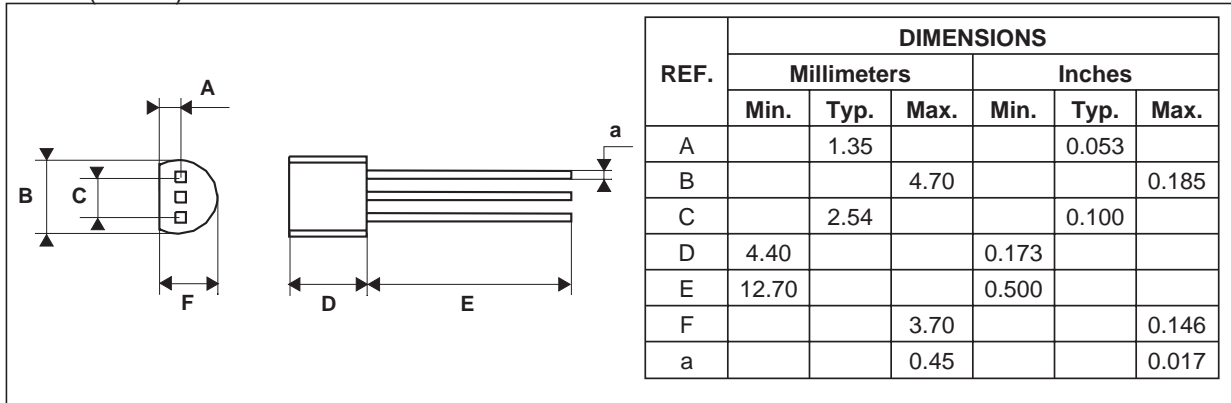

### OTHER INFORMATION

| Ordering type | Marking | Package | Weight | Base qty | Delivery mode |
|---------------|---------|---------|--------|----------|---------------|
| ACS102-5TA    | ACS102  | TO-92   | 0.2g   | 2500     | Bulk          |
| ACS102-5TA-TR | ACS102  | TO-92   | 0.2g   | 2000     | Tape & reel   |
| ACS102-5T1    | ACS102  | SO-8    | 0.11g  | 100      | Tube          |
| ACS102-5T1-TR | ACS102  | SO-8    | 0.11g  | 2500     | Tape & reel   |

ASD and ACS are a trademarks of STMicroelectronics.

Information furnished is believed to be accurate and reliable. However, STMicroelectronics assumes no responsibility for the consequences of use of such information nor for any infringement of patents or other rights of third parties which may result from its use. No license is granted by implication or otherwise under any patent or patent rights of STMicroelectronics. Specifications mentioned in this publication are subject to change without notice. This publication supersedes and replaces all information previously supplied. STMicroelectronics products are not authorized for use as critical components in life support devices or systems without express written approval of STMicroelectronics.

The ST logo is a registered trademark of STMicroelectronics

© 2001 STMicroelectronics - Printed in Italy - All rights reserved.

STMicroelectronics GROUP OF COMPANIES

Australia - Brazil - China - Finland - France - Germany - Hong Kong - India - Italy - Japan - Malaysia  
Malta - Morocco - Singapore - Spain - Sweden - Switzerland - United Kingdom - U.S.A.

<http://www.st.com>



LittleDiode supplies new, hard to find or obsolete electronic components and semiconductors all over the world.

With over two million different components listed you are sure to find the part you need.

Feel free to visit us today at our online store:

[LittleDiode.com](http://LittleDiode.com)

Looking forward to providing you with the best possible service.