

FEATURES

- AC '97 2.3 COMPATIBLE FEATURES
- S/PDIF Output, 20 Bits Data Format, Supporting 48 kHz and 44.1 kHz Sample Rates
- Integrated Stereo Headphone Amplifier
- Variable Sample Rate Audio
- External Audio Power-Down Control
- Greater than 90 dB Dynamic Range
- Stereo Full-Duplex Codec
- 20-Bit PCM DAC
- 3 Analog Line-Level Stereo Inputs for Line-In, AUX, and CD
- Mono Line-Level Phone Input
- Dual MIC Input with Built-In Programmable Preamp
- High Quality CD Input with Ground Sense

- Mono Output for Speakerphone or Internal Speaker
- Power Management Support
- 48-Lead LQFP Package, Lead-Free Package Available

ENHANCED FEATURES

- Stereo MIC Preamps Support
- Built-In Digital Equalizer Function for Optimized Speaker Sound
- Full-Duplex Variable Sample Rates from 7040 Hz to 48 kHz with 1 Hz Resolution
- Jack Sense Pins Provide Automatic Output Switching
- Software Programmed V_{REFOUT} Output for Biasing Microphone and External Power Amp
- Low Power 3.3 V Operation for Analog and Digital Supplies
- Multiple Codec Configuration Options

FUNCTIONAL BLOCK DIAGRAM

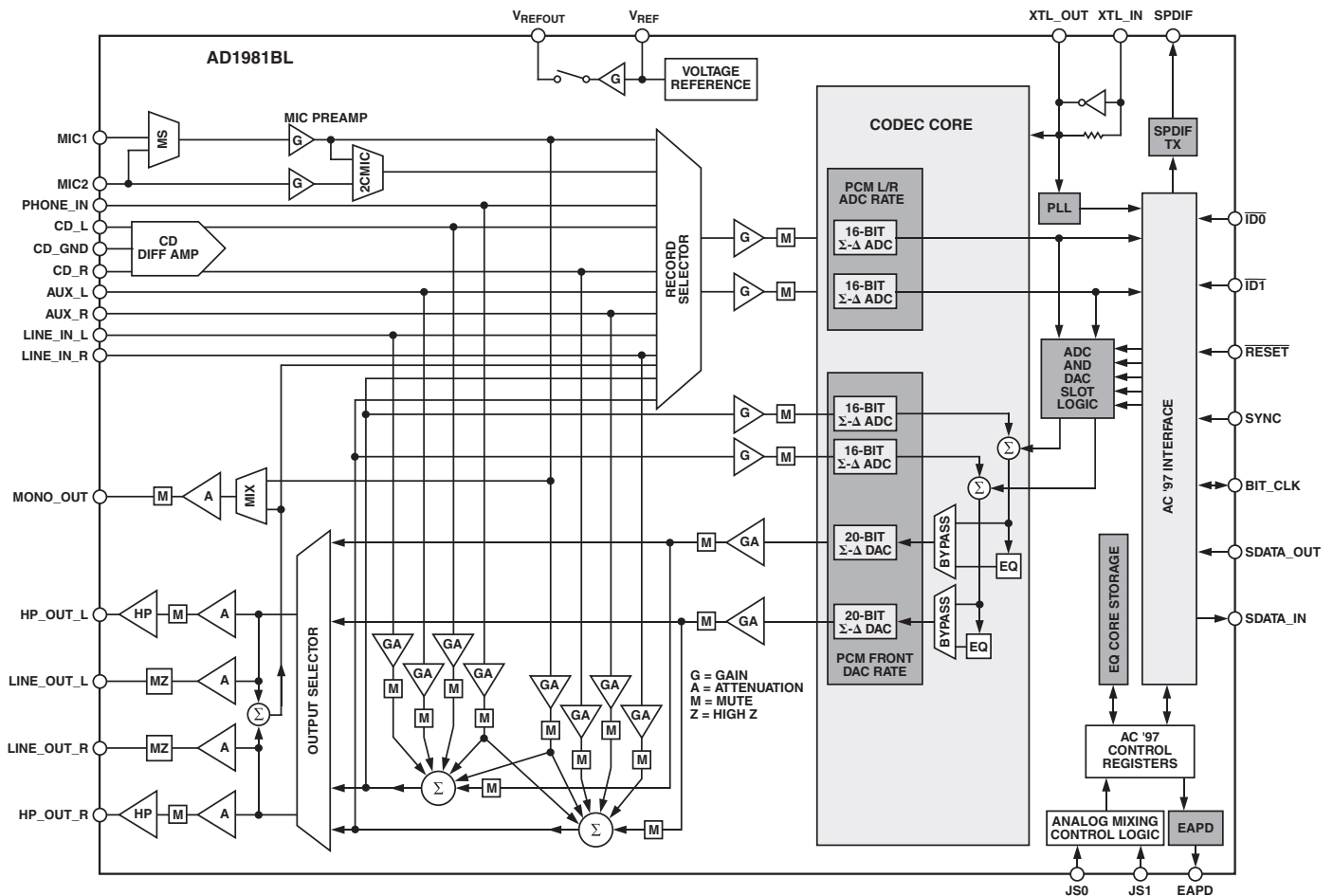

REV. 0

Information furnished by Analog Devices is believed to be accurate and reliable. However, no responsibility is assumed by Analog Devices for its use, nor for any infringements of patents or other rights of third parties that may result from its use. No license is granted by implication or otherwise under any patent or patent rights of Analog Devices. Trademarks and registered trademarks are the property of their respective owners.

AD1981BL—SPECIFICATIONS

STANDARD TEST CONDITIONS, UNLESS OTHERWISE NOTED

Temperature	25°C
Digital Supply (DVDD)	3.3 V
Analog Supply (AVDD)	3.3 V
Sample Rate (f_s)	48 kHz
Input Signal	1008 Hz
Analog Output Pass Band	20 Hz to 20 kHz

DAC Test Conditions

Calibrated
-3 dB Attenuation Relative to Full Scale
0 dB Input
10 k Ω Output Load (LINE_OUT)
32 Ω Output Load (HP_OUT)

ADC Test Conditions

Calibrated
0 dB Gain
Input -3.0 dB Relative to Full Scale

Parameter	Min	Typ	Max	Unit
ANALOG INPUT				
Input Voltage (RMS Values Assume Sine Wave Input) LINE_IN, AUX, CD, PHONE_IN		0.707		V rms
		2.0		V p-p
MIC_IN with +20 dB Gain		0.0707		V rms
		0.2		V p-p
MIC_IN with 0 dB Gain		0.707		V rms
		2.0		V p-p
Input Impedance ¹		20		k Ω
Input Capacitance ¹		5	7.5	pF
MASTER VOLUME				
Step Size (0 dB to -46.5 dB): LINE_OUT_L, LINE_OUT_R		1.5		dB
Output Attenuation Range ¹		46.5		dB
Step Size (0 dB to -46.5 dB): MONO_OUT		1.5		dB
Output Attenuation Range ¹		46.5		dB
Step Size (0 dB to -46.5 dB): HP_OUT_R, HP_OUT_L		1.5		dB
Output Attenuation Range Span ¹		46.5		dB
Mute Attenuation of 0 dB Fundamental ¹	80			dB
PROGRAMMABLE GAIN AMPLIFIER—ADC				
Step Size (0 dB to 22.5 dB)		1.5		dB
PGA Gain Range		22.5		dB
ANALOG MIXER—INPUT GAIN/AMPLIFIERS/ATTENUATORS				
Signal-to-Noise Ratio (SNR) CD to LINE_OUT		90		dB
Other to LINE_OUT ¹		90		dB
Step Size (+12 dB to -34.5 dB) (All Steps Tested): MIC_IN, LINE_IN, CD, AUX, PHONE_IN, DAC		1.5		dB
Input Gain/Attenuation Range: MIC_IN, LINE_IN, CD, AUX, PHONE_IN, DAC		46.5		dB
DIGITAL DECIMATION AND INTERPOLATION FILTERS¹				
Pass Band	0		$0.4 \times f_s$	Hz
Pass-Band Ripple			± 0.09	dB
Transition Band	$0.4 \times f_s$		$0.6 \times f_s$	Hz
Stop Band	$0.6 \times f_s$		∞	Hz
Stop-Band Rejection	-74			dB
Group Delay		$16/f_s$		sec
Group Delay Variation over Pass Band		0		μ s

Parameter	Min	Typ	Max	Unit
ANALOG-TO-DIGITAL CONVERTERS				
Resolution		16		Bits
Total Harmonic Distortion (THD)		-87		dB
Dynamic Range (-60 dB Input THD+N Referenced to Full Scale, A-Weighted)	78	83		dB
Signal-to-Intermodulation Distortion ¹ (CCIF Method)		85		dB
ADC Crosstalk ¹				
Line Inputs (Input L, Ground R, Read R; Input R, Ground L, Read L)		-80		dB
Line_In to Other		-100	-80	dB
Gain Error ² (Full-Scale Span Relative to Nominal Input Voltage)			±10	%
Interchannel Gain Mismatch (Difference of Gain Errors)			±0.5	dB
ADC Offset Error ¹			±5	mV
DIGITAL-TO-ANALOG CONVERTERS				
Resolution		20		Bits
Total Harmonic Distortion (THD) LINE_OUT		-88		dB
Total Harmonic Distortion (THD) HP_OUT		-81		dB
Dynamic Range (-60 dB Input THD+N Referenced to Full Scale, A-Weighted)	82	87.5		dB
Signal-to-Intermodulation Distortion ¹ (CCIF Method)		-100		dB
Gain Error ² (Output FS Voltage Relative to Nominal Output FS Voltage)			±10	%
Interchannel Gain Mismatch (Difference of Gain Errors)			±0.7	dB
DAC Crosstalk ¹ (Input L, Zero R, Measure R_OUT; Input R, Zero L, Measure L_OUT)			-80	dB
ANALOG OUTPUT				
Full-Scale Output Voltage; LINE_OUT and MONO_OUT		0.707 2.0		V rms V p-p
Output Impedance ¹			800	Ω
External Load Impedance ¹	10			kΩ
Output Capacitance ¹		15		pF
External Load Capacitance ¹			100	pF
Full-Scale Output Voltage; HP_OUT (0 dB Gain)		1		V rms
External Load Impedance ¹	32			Ω
V _{REF}	1	1.12	1.225	V
V _{REF_OUT}		2.25		V
V _{REF_OUT} Current Drive			5	mA
Mute Click (Muted Output Minus Unmuted Midscale DAC Output)		±5		mV
STATIC DIGITAL SPECIFICATIONS				
High Level Input Voltage (V _{IH}): Digital Inputs	0.65 × DVDD			V
Low Level Input Voltage (V _{IL})			0.35 × DVDD	V
High Level Output Voltage (V _{OH}), I _{OH} = 2 mA	0.9 × DVDD			V
Low Level Output Voltage (V _{OL}), I _{OL} = 2 mA			0.1 × DVDD	V
Input Leakage Current	-10		+10	μA
Output Leakage Current	-10		+10	μA
POWER SUPPLY				
Power Supply Range—(AV _{DD} and DV _{DD})	3.0		3.47	V
Power Dissipation		287		mW
Analog Supply Current—3.3 V (AV _{DD})		39		mA
Digital Supply Current—3.3 V (DV _{DD})		48		mA
Power Supply Rejection (100 mV p-p Signal @ 1 kHz) ¹ (At Both Analog and Digital Supply Pins, Both ADCs and DACs)		40		dB

AD1981BL

SPECIFICATIONS (continued)

Parameter	Min	Typ	Max	Unit
CLOCK SPECIFICATIONS¹				
Input Clock Frequency		24.576		MHz
Recommended Clock Duty Cycle	40	50	60	%

NOTES

¹Guaranteed but not tested.

²Measurements reflect main ADC.

Specifications subject to change without notice.

Parameter	Set Bits	DV _{DD} Typ	AV _{DD} Typ	Unit
POWER-DOWN STATES*				
(Fully Active)	(No Bits Value)	47.76	38.9	mA
ADC	PR0	40.1	34.39	mA
DAC	PR1	32.8	26.3	mA
ADC + DAC	PR1, PR0	13.2	20.55	mA
Mixer	PR2	47.7	19.39	mA
ADC + Mixer	PR2, PR0	40	14.86	mA
DAC + Mixer	PR2, PR1	32.77	6.39	mA
ADC + DAC + Mixer	PR2, PR1, PR0	13.9	1.15	mA
Standby	PR5, PR4, PR3, PR2, PR1, PR0	0	0	mA
Headphone Standby	PR6	47.7	32	mA

*Values presented with V_{REFOUT} not loaded.

Specifications subject to change without notice.

TIMING PARAMETERS (Guaranteed over Operating Temperature Range)

Parameter	Symbol	Min	Typ	Max	Unit
RESET Active Low Pulse Width	t _{RST_LOW}		1.0		ms
RESET Inactive to BIT_CLK Start-Up Delay	t _{RST2CLK}	162.8			ns
SYNC Active High Pulse Width	t _{SYNC_HIGH}		1.3		μs
SYNC Low Pulse Width	t _{SYNC_LOW}		19.5		μs
SYNC Inactive to BIT_CLK Start-Up Delay	t _{SYNC2CLK}	162.8			ns
BIT_CLK Frequency			12.288		MHz
BIT_CLK Frequency Accuracy				±1	ppm
BIT_CLK Period	t _{CLK_PERIOD}		81.4		ns
BIT_CLK Output Jitter ^{1, 2, 3}			750	2000	ps
BIT_CLK High Pulse Width	t _{CLK_HIGH}	32.56	42	48.84	ns
BIT_CLK Low Pulse Width	t _{CLK_LOW}	32.56	38		ns
SYNC Frequency			48.0		kHz
SYNC Period	t _{SYNC_PERIOD}		20.8		ms
Setup to Falling Edge of BIT_CLK	t _{SETUP}	5	2.5		ns
Hold from Falling Edge of BIT_CLK	t _{HOLD}	5			ns
BIT_CLK Rise Time	t _{RISECLK}	2	4	6	ns
BIT_CLK Fall Time	t _{FALLCLK}	2	4	6	ns
SYNC Rise Time	t _{RISESYNC}	2	4	6	ns
SYNC Fall Time	t _{FALLSYNC}	2	4	6	ns
SDATA_IN Rise Time	t _{RISEDIN}	2	4	6	ns
SDATA_IN Fall Time	t _{FALLDIN}	2	4	6	ns
SDATA_OUT Rise Time	t _{RISEDOUT}	2	4	6	ns
SDATA_OUT Fall Time	t _{FALLDOUT}	2	4	6	ns
End of Slot 2 to BIT_CLK, SDATA_IN Low	t _{S2_PDOW}	0		1.0	ms
Setup to Trailing Edge of RESET (Applies to SYNC, SDATA_OUT)	t _{SETUP2RST}	15			ns
Rising Edge of RESET to Hi-Z Delay	t _{OFF}			25	ns
Propagation Delay				15	ns
RESET Rise Time				50	ns
Output Valid Delay from Rising Edge of BIT_CLK to SDI Valid				15	ns

NOTES

¹Guaranteed but not tested.

²Output jitter is directly dependent on crystal input jitter.

³Maximum jitter specification for noncrystal operation only. Crystal operation maximum is much lower.

Specifications subject to change without notice.

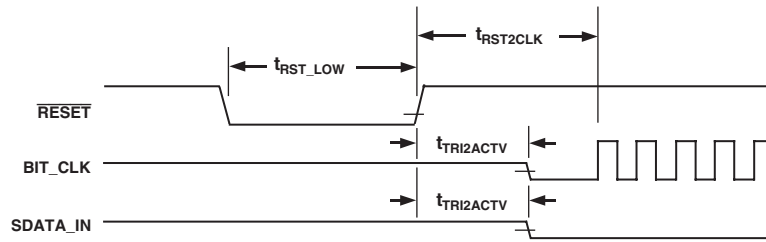

Figure 1. Cold Reset Timing (Codec Is Supplying the BIT_CLK Signal)

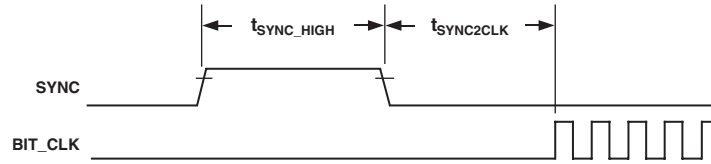

Figure 2. Warm Reset Timing

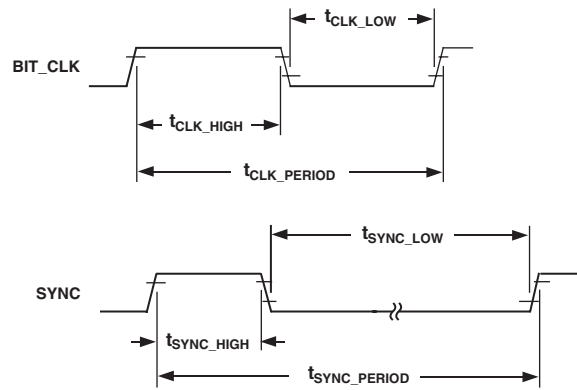

Figure 3. Clock Timing

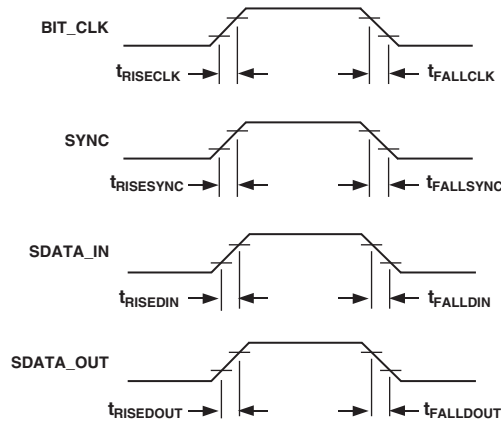

Figure 4. Signal Rise and Fall Times

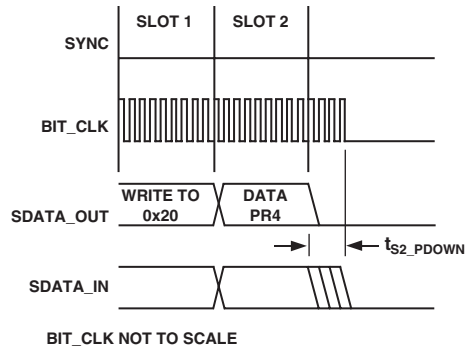

Figure 5. AC-Link Low Power Mode Timing

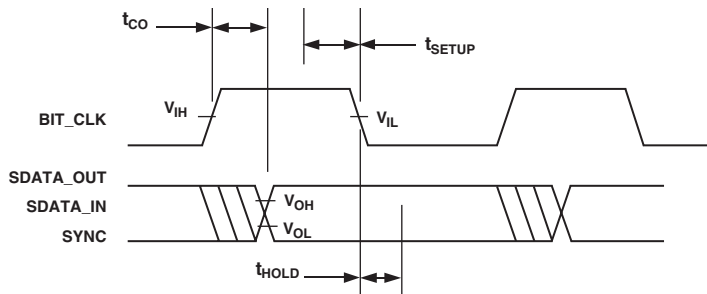

Figure 6. AC-Link Low Power Mode Timing, SYNC and BIT_CLK Chopped

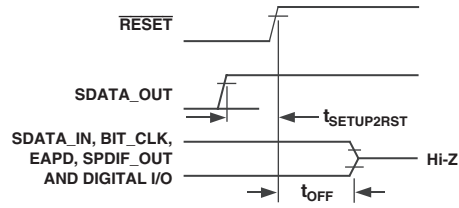

Figure 7. ATE Test Mode

ABSOLUTE MAXIMUM RATINGS*

(T_A = 25°C, unless otherwise noted.)

Power Supplies

Digital (DV_{DD}) -0.3 V to +3.6 V

Analog (AV_{DD}) -0.3 V to +6.0 V

Input Current (Except Supply Pins) ±10 mA

Signals Pins

Digital Input Voltage -0.3 V to DV_{DD} + 0.3 V

Analog Input Voltage -0.3 V to AV_{DD} + 0.3 V

Ambient Temperature Range (Operating) 0°C to 70°C

*Stresses greater than those listed under Absolute Maximum Ratings may cause permanent damage to the device. This is a stress rating only; functional operation of the device at these or any other conditions above those indicated in the operational section of this specification is not implied. Exposure to absolute maximum rating conditions for extended periods may affect device reliability.

ENVIRONMENTAL CONDITIONS*

Ambient Temperature Rating (LQFP Package)

T_{CASE} = Case Temperature in °C

PD = Power Dissipation in W

θ_{JA} Thermal Resistance (Junction to Ambient)

θ_{JC} Thermal Resistance (Junction to Case)

Package	θ _{JA}	θ _{JC}
LQFP	50.1°C/W	17.8°C/W

*All measurements per EIA-JESD51 with 2S2P test board per EIA-JESD51-7

ORDERING GUIDE

Model	Temperature Range	Package Description	Package Option ¹
AD1981BLJST	0°C to 70°C	48-Lead LQFP (Tray)	ST-48
AD1981BLJST-REEL	0°C to 70°C	48-Lead LQFP (Reel)	ST-48
AD1981BLJSTZ ²	0°C to 70°C	48-Lead LQFP (Tray)	ST-48
AD1981BLJSTZ-REEL ²	0°C to 70°C	48-Lead LQFP (Reel)	ST-48

NOTES

¹ST = Low Profile Quad Flatpack.

²The AD1981BLJSTZ is a lead-free environmentally friendly product. It is manufactured using the most up-to-date materials and processes. The coating on the leads of each device is 100% pure tin electroplate. The device is suitable for lead-free applications and is able to withstand surface-mount soldering at up to 255°C (±5°C). In addition, it is backward compatible with conventional tin-lead soldering processes. This means that the electroplated tin coating can be soldered with tin-lead solder pastes at reflow temperatures of 220°C to 235°C.

CAUTION

ESD (electrostatic discharge) sensitive device. Electrostatic charges as high as 4000 V readily accumulate on the human body and test equipment and can discharge without detection. Although the AD1981BL features proprietary ESD protection circuitry, permanent damage may occur on devices subjected to high energy electrostatic discharges. Therefore, proper ESD precautions are recommended to avoid performance degradation or loss of functionality.



PIN CONFIGURATION 48-Lead LQFP

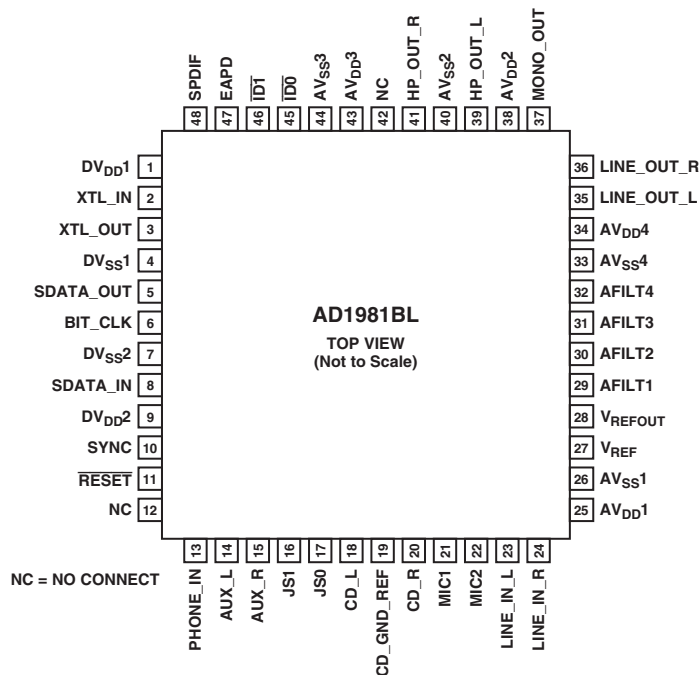

AD1981BL

PIN FUNCTION DESCRIPTIONS

Pin No.	Mnemonic	I/O	Function
DIGITAL I/O			
2	XTL_IN	I	Crystal Input (24.576 MHz) or External Clock Input.
3	XTL_OUT	O	Crystal Output.
5	SDATA_OUT	I	AC-Link Serial Data Output, AD1981BL Data Input Stream.
6	BIT_CLK	O/I	AC-Link Bit Clock Output (12.288 MHz) or Bit Clock Input if Secondary Mode Selected.
8	SDATA_IN	O	AC-Link Serial Data Input, AD1981BL Data Output Stream.
10	SYNC	I	AC-Link Frame Sync.
11	RESET	I	AC-Link Reset, AD1981BL Master Hardware Reset.
48	SPDIF	O	S/PDIF Output.
CHIP SELECTS (These pins can also be used to select an external clock. See Table IX.)			
45	$\overline{\text{ID0}}$	I	Chip Select Input 0 (Active Low). This pin can also be used as the chain input from a secondary codec.
46	$\overline{\text{ID1}}$	I	Chip Select Input 1 (Active Low).
JACK SENSE AND EAPD			
17	JS0	I	Jack Sense 0 Input.
16	JS1	I	Jack Sense 1 Input.
47	EAPD	O	External Amp Power-Down Control.
ANALOG I/O			
13	PHONE_IN	I	Phone Input. Mono input from telephony subsystem speaker phone or handset.
14	AUX_L	I	Auxiliary Input Left Channel.
15	AUX_R	I	Auxiliary Input Right Channel.
18	CD_L	I	CD Audio Left Channel.
19	CD_GND_REF	I	CD Audio Analog Ground Reference for Differential CD Input.
20	CD_R	I	CD Audio Right Channel.
21	MIC1	I	Microphone 1 Input (Mono) or Left Channel when 2-Channel Mode Selected (Stereo MIC).
22	MIC2	I	Microphone 2 Input (Mono) or Right Channel when 2-Channel Mode Selected (Stereo MIC).
23	LINE_IN_L	I	Line In Left Channel.
24	LINE_IN_R	I	Line In Right Channel.
35	LINE_OUT_L	O	Line Out (Front) Left Channel.
36	LINE_OUT_R	O	Line Out (Front) Right Channel.
37	MONO_OUT	O	Monaural Output to Telephony Subsystem Speakerphone.
39	HP_OUT_L	O	Headphone Left Channel Output.
41	HP_OUT_R	O	Headphone Right Channel Output.
FILTER/REFERENCE (These signals are connected to resistors, capacitors, or specific voltages.)			
27	V _{REF}	O	Voltage Reference Filter.
28	V _{REFOUT}	O	Voltage Reference Output 5 mA Drive (Intended for MIC Bias and Power Amp Bias).
29	AFILT1	O	Antialiasing Filter Capacitor—ADC Right Channel.
30	AFILT2	O	Antialiasing Filter Capacitor—ADC Left Channel.
31	AFILT3	O	Antialiasing Filter Capacitor—Mixer ADC Right Channel.
32	AFILT4	O	Antialiasing Filter Capacitor—Mixer ADC Left Channel.
POWER AND GROUND SIGNALS			
1	DV _{DD1}	I	Digital V _{DD} 3.3 V.
4	DV _{SS1}	I	Digital GND.
7	DV _{SS2}	I	Digital GND.
9	DV _{DD2}	I	Digital V _{DD} 3.3 V.
25	AV _{DD1}	I	Analog V _{DD} 5.0 V.
26	AV _{SS1}	I	Analog GND.
38	AV _{DD2}	I	Analog V _{DD} 5.0 V.
40	AV _{SS2}	I	Analog GND.
43	AV _{DD3}	I	Analog V _{DD} 5.0 V.
44	AV _{SS3}	I	Analog GND.
34	AV _{DD4}	I	Analog V _{DD} 5.0 V.
33	AV _{SS4}	I	Analog GND.
NO CONNECTS			
12	NC		No Connect.
42	NC		No Connect.

Indexed Control Registers

Reg	Name	D15	D14	D13	D12	D11	D10	D9	D8	D7	D6	D5	D4	D3	D2	D1	D0	Default
00h	Reset	X	SE4	SE3	SE2	SE1	SE0	ID9	ID8	ID7	ID6	ID5	ID4	ID3	ID2	ID1	ID0	0090h
02h	Master Volume	MM	X	X	LMV4	LMV3	LMV2	LMV1	LMV0	RM*	X	X	RMV4	RMV3	RMV2	RMV1	RMV0	8000h
04h	Headphones Volume	HPM	X	X	LHV4	LHV3	LHV2	LHV1	LHV0	RM*	X	X	RHV4	RHV3	RHV2	RHV1	RHV0	8000h
06h	Mono Volume	MVM	X	X	X	X	X	X	X	X	X	X	MV4	MV3	MV2	MV1	MV0	8000h
0Ch	Phone Volume	PHM	X	X	X	X	X	X	X	X	X	X	PHV4	PHV3	PHV2	PHV1	PHV0	8008h
0Eh	MIC Volume	MCM	X	X	X	X	X	X	X	X	M20	X	MCV4	MCV3	MCV2	MCV1	MCV0	8008h
10h	Line-In Volume	LVM	X	X	LLV4	LLV3	LLV2	LLV1	LLV0	RM*	X	X	RLV4	RLV3	RLV2	RLV1	RLV0	8808h
12h	CD Volume	CVM	X	X	LCV4	LCV3	LCV2	LCV1	LCV0	RM*	X	X	RCV4	RCV3	RCV2	RCV1	RCV0	8808h
16h	AUX Volume	AM	X	X	LAV4	LAV3	LAV2	LAV1	LAV0	RM*	X	X	RAV4	RAV3	RAV2	RAV1	RAV0	8808h
18h	PCM-Out Vol	OM	X	X	LOV4	LOV3	LOV2	LOV1	LOV0	RM*	X	X	ROV4	ROV3	ROV2	ROV1	ROV0	8808h
1Ah	Record Select	X	X	X	X	X	LS2	LS1	LS0	X	X	X	X	X	RS2	RS1	RS0	0000h
1Ch	Record Gain	IM	X	X	X	LIM3	LIM2	LIM1	LIM0	RM*	X	X	X	RIM3	RIM2	RIM1	RIM0	8000h
20h	General-Purpose	X	X	X	X	X	X	MIX	MS	LPBK	X	X	X	X	X	X	X	0000h
26h	Power-Down Ctrl/Stat	EAPD	PR6	PR5	PR4	PR3	PR2	PR1	PR0	X	X	X	X	REF	ANL	DAC	ADC	000Xh
28h	Ext'd Audio ID	IDC1	IDC0	X	X	REVC1	REVC0	AMAP	X	X	X	DSA1	DSA0	X	SPDIF	X	VRAS	X605h
2Ah	Ext'd Audio Stat/ Ctrl	VFORCE	X	X	X	X	SPCV	X	X	X	X	SPSA1	SPSA0	X	SPDIF	X	VRA	0000h
2Ch	PCM Front DAC Rate	SRF15	SRF14	SRF13	SRF12	SRF11	SRF10	SRF9	SRF8	SRF7	SRF6	SRF5	SRF4	SRF3	SRF2	SRF1	SRF0	BB80h
32h	PCM L/R ADC Rate	SRA15	SRA14	SRA13	SRA12	SRA11	SRA10	SRA9	SRA8	SRA7	SRA6	SRA5	SRA4	SRA3	SRA2	SRA1	SRA0	BB80h
3Ah	SPDIF Control	V	X	SPSR1	SPSR0	L	CC6	CC5	CC4	CC3	CC2	CC1	CC0	PRE	COPY	/AUD	PRO	2000h
60h	EQ CTRL	EQM	MAD LBEN	X	X	X	X	X	X	SYM	CHS	BCA5	BCA4	BCA3	BCA2	BCA1	BCA0	8080h
62h	EQ DATA	CFD15	CFD14	CFD13	CFD12	CFD11	CFD10	CFD9	CFD8	CFD7	CFD6	CFD5	CFD4	CFD3	CFD2	CFD1	CFD0	0000h
64h	Mixer ADC, Volume	MXM	X	X	X	LMG3	LMG2	LMG1	LMG0	RM*	X	X	X	RMG3	RMG2	RMG1	RMG0	8000h
72h	Jack Sense	X	X	X	JS MT2	JS MT1	JS MT0	JS1 EQB	JS0 EQB	JS1 TMR	JS0 TMR	JS1 MD	JS0 MD	JS1 ST	JS0 ST	JS1 INT	JS0 INT	0000h
74h	Serial Configuration	SLOT 16	REGM 2	REGM 1	REGM 0	X	X	X	CHEN	X	X	X	INTS	X	SPAL	SPDZ	SPLNK	7001h
76h	Misc Control Bits	DACZ	X	M SPLT	LODIS	DAM	X	FMXE	X	MAD PD	2CMIC	X	MAD ST	VREF H	VREF D	MBG1	MBG0	0000h
7Ch	Vendor ID1	F7	F6	F5	F4	F3	F2	F1	F0	S7	S6	S5	S4	S3	S2	S1	S0	4144h
7Eh	Vendor ID2	T7	T6	T5	T4	T3	T2	T1	T0	REV7	REV6	REV5	REV4	REV3	REV2	REV1	REV0	5374h

NOTES

All registers not shown. Bits containing an X are assumed to be reserved.

Odd register addresses are aliased to the next lower even address.

Reserved registers should not be written.

Zeros should be written to reserved bits.

*For AC '97 compatibility, Bit D7 (RM) is available only by setting the MSPLT bit, Register 76h. The MSPLT bit enables separate mute bits for the left and right channels. If MSPLT is not set, RM bit has no effect.

AD1981BL

Reset Register (Index 00h)

Reg No.	Name	D15	D14	D13	D12	D11	D10	D9	D8	D7	D6	D5	D4	D3	D2	D1	D0	Default
00h	Reset	X	SE4	SE3	SE2	SE1	SE0	ID9	ID8	ID7	ID6	ID5	ID4	ID3	ID2	ID1	ID0	0090h

NOTES

X in the above table is a wild card and has no effect on the value.

Writing any value to this register performs a register reset that causes all registers to revert to their default values (except 74h, which forces the serial configuration).

Reading this register returns the ID code of the part and a code for the type of 3D stereo enhancement.

ID[9:0] Identify Capability. The ID decodes the capabilities of AD1981BL based on the following:

Bit	Function	AD1981BL
ID0	Dedicated Mic PCM In Channel	0
ID1	Modem Line Codec Support	0
ID2	Bass and Treble Control	0
ID3	Simulated Stereo (Mono to Stereo)	0
ID4	Headphone Out Support	1
ID5	Loudness (Bass Boost) Support	0
ID6	18-Bit DAC Resolution	0
ID7	20-Bit DAC Resolution	1
ID8	18-Bit ADC Resolution	0
ID9	20-Bit ADC Resolution	0

SE[4:0] Stereo Enhancement. The AD1981BL does not provide hardware 3D stereo enhancement (all bits are zeros).

Master Volume Register (Index 02h)

Reg No.	Name	D15	D14	D13	D12	D11	D10	D9	D8	D7	D6	D5	D4	D3	D2	D1	D0	Default
02h	Master Volume	MM	X	X	LMV4	LMV3	LMV2	LMV1	LMV0	RM*	X	X	RMV4	RMV3	RMV2	RMV1	RMV0	8000h

* For AC '97 compatibility, Bit D7 (RM) is available only by setting the MSPLT bit, Register 76h. The MSPLT bit enables separate mute bits for the left and right channels. If MSPLT is not set, RM bit has no effect. All registers not shown and bits containing an X are assumed to be reserved.

Refer to Table I for examples. This register controls the Line_Out volume controls for both stereo channels and the mute bit. Each volume subregister contains five bits, generating 32 volume levels with 31 steps of 1.5 dB each. Because AC '97 defines 6-bit volume registers, to maintain compatibility whenever the D5 or D13 bits are set to 1, their respective lower five volume bits are automatically set to 1 by the codec logic. On readback, all lower five bits will read 1s whenever these bits are set to 1.

RMV[4:0]	Right Master Volume Control. The least significant bit represents 1.5 dB. This register controls the output from 0 dB to a maximum attenuation of 46.5 dB.
RM	Right Channel Mute. Once enabled by the MSPLT bit in Register 76h, this bit mutes the right channel separately from the MM bit. Otherwise, this bit will always read 0 and will have no effect when set to 1.
LMV[4:0]	Left Master Volume Control. The least significant bit represents 1.5 dB. This register controls the output from 0 dB to a maximum attenuation of 46.5 dB.
MM	Master Volume Mute. When this bit is set to 1, both the left and right channels are muted, unless the MSPLT bit in Register 76h is set to 1, in which case this mute bit will affect only the left channel.

Headphones Volume Register (Index 04h)

Reg No.	Name	D15	D14	D13	D12	D11	D10	D9	D8	D7	D6	D5	D4	D3	D2	D1	D0	Default
04h	Headphone Volume	HPM	X	X	LHV 4	LHV 3	LHV 2	LHV 1	LHV 0	RM*	X	X	RHV 4	RHV 3	RHV 2	RHV 1	RHV 0	8000h

*For AC '97 compatibility, Bit D7 (RM) is available only by setting the MSPLT bit, Register 76h. The MSPLT bit enables separate mute bits for the left and right channels. If MSPLT is not set, RM bit has no effect. All registers not shown, and bits containing an X are assumed to be reserved.

Refer to Table I for examples. This register controls the headphone volume controls for both stereo channels and mute bit. Each volume subregister contains five bits, generating 32 volume levels with 31 steps of 1.5 dB each. Because AC '97 defines 6-bit volume registers, to maintain compatibility, whenever the D5 or D13 bits are set to 1, their respective lower five volume bits are automatically set to 1 by the codec logic. On readback, all lower five bits will read 1s whenever these bits are set to 1.

RHV [4:0]	Right Headphone Volume Control. The least significant bit represents 1.5 dB. This register controls the output from 0 dB to a maximum attenuation of 46.5 dB.
RM	Right Channel Mute. Once enabled by the MSPLT bit in Register 76h, this bit mutes the right channel separately from the HPM bit. Otherwise, this bit will always read 0 and will have no effect when set to 1.
LHV [4:0]	Left Headphone Volume Control. The least significant bit represents 1.5 dB. This register controls the output from 0 dB to a maximum attenuation of 46.5 dB.
HPM	Headphones Volume Mute. When this bit is set to 1, both the left and right channels are muted, unless the MSPLT bit in Register 76h is set to 1, in which case this mute bit will affect only the left channel.

Table I. Volume Settings for Master and Headphone

Reg. 76h	Control Bits							
	Master Volume (02h) and Headphone Volume (04h)							
MSPLT*	Left Channel Volume D[13:8]				Right Channel Volume D[5:0]			
	D15	Write	Readback	Function	D7*	Write	Readback	Function
0	0	00 0000	00 0000	0 dB Gain	x	00 0000	00 0000	0 dB Gain
0	0	00 1111	00 1111	-22.5 dB Gain	x	00 1111	00 1111	-22.5 dB Gain
0	0	01 1111	01 1111	-46.5 dB Gain	x	01 1111	01 1111	-46.5 dB Gain
0	0	1x xxxx	01 1111	-46.5 dB Gain	x	1x xxxx	01 1111	-46.5 dB Gain
0	1	xx xxxx	xx xxxx	-∞ dB Gain, Muted	x	xx xxxx	xx xxxx	-∞ dB Gain, Muted
1	0	1x xxxx	01 1111	-46.5 dB Gain	1	xx xxxx	xx xxxx	-∞ dB Gain, Right Only Muted
1	1	xx xxxx	xx xxxx	-∞ dB Gain, Left Only Muted	0	xx xxxx	xx xxxx	-46.5 dB Gain
1	1	xx xxxx	xx xxxx	-∞ dB Gain, Left Muted	1	xx xxxx	xx xxxx	-∞ dB Gain, Right Muted

*For AC '97 compatibility, Bit D7 (RM) is available only by setting the MSPLT bit, Register 76h. The MSPLT bit enables separate mute bits for the left and right channels. If MSPLT is not set, RM bit has no effect.

x in the above table is a wild card and has no effect on the value.

AD1981BL

Mono Volume Register (Index 06h)

Reg No.	Name	D15	D14	D13	D12	D11	D10	D9	D8	D7	D6	D5	D4	D3	D2	D1	D0	Default
06h	Mono Volume	MVM	X	X	X	X	X	X	X	X	X	X	MV4	MV3	MV2	MV1	MV0	8000h

All registers not shown and bits containing an X are assumed to be reserved.

Refer to Table II for examples. This register controls the mono output volume and mute bit. The volume register contains five bits, generating 32 volume levels with 31 steps of 1.5 dB each. Because AC '97 defines 6-bit volume registers, to maintain compatibility, whenever the D5 bit is set to 1, their respective lower five volume bits are automatically set to 1 by the codec logic. On readback, all lower five bits will read 1s whenever this bit is set to 1.

MV[4:0]	Mono Volume Control. The least significant bit represents 1.5 dB. This register controls the output from 0 dB to a maximum attenuation of 46.5 dB.
MVM	Mono Volume Mute. When this bit is set to 1, the channel is muted.

Table II. Volume Settings for Mono

D15	Control Bits D[4:0] for Mono (06h)		Function
	WRITE	READBACK	
0	0000	0 0000	0 dB Gain
0	0 1111	0 1111	-22.5 dB Gain
0	1 1111	1 1111	-46.5 dB Gain
1	x xxxx	x xxxx	-∞ dB Gain, Muted

x in the above table is a wild card and has no effect on the value.

Phone Volume Register (Index 0Ch)

Reg No.	Name	D15	D14	D13	D12	D11	D10	D9	D8	D7	D6	D5	D4	D3	D2	D1	D0	Default
0Ch	Phone Volume	PHM	X	X	X	X	X	X	X	X	X	X	PHV4	PHV3	PHV2	PHV1	PHV0	8008h

All registers not shown and bits containing an X are assumed to be reserved. Refer to Table III for examples.

PHV[4:0]	Phone Volume. Allows setting the phone volume attenuator in 32 volume levels with 31 steps of 1.5 dB each. The LSB represents 1.5 dB, and the gain range is +12 dB to -34.5 dB. The default value is 0 dB, with the mute bit enabled.
PHM	Phone Mute. When this bit is set to 1, the phone channel is muted.

All registers not shown and bits containing an X are assumed to be reserved. Refer to Table III for examples.

MIC Volume Register (Index 0Eh)

Reg No.	Name	D15	D14	D13	D12	D11	D10	D9	D8	D7	D6	D5	D4	D3	D2	D1	D0	Default
0Eh	MIC Volume	MCM	X	X	X	X	X	X	X	X	M20	X	MCV4	MCV3	MCV2	MCV1	MCV0	8008h

All registers not shown and bits containing an X are assumed to be reserved. Refer to Table III for examples.

MCV[4:0]	MIC Volume Gain. Allows setting the phone volume attenuator in 32 volume levels with 31 steps of 1.5 dB each. The LSB represents 1.5 dB, and the gain range is +12 dB to -34.5 dB. The default value is 0 dB, with the mute bit enabled.
M20	MIC Gain Boost. This bit allows setting additional MIC gain to increase the microphone sensitivity. The nominal gain boost by default is 20 dB; however, Bits D0 and D1 (MBG[1:0]) on the miscellaneous control bits register (76h) allow changing the gain boost to 10 dB or 30 dB if necessary. 0 = Disabled; Gain = 0 dB 1 = Enabled; Default Gain = 20 dB (see Register 76h, Bits D0, D1)
MCM	MIC Mute. When this bit is set to 1, the MIC channel is muted.

Table III. Volume Settings for Phone and MIC

D15	Control Bits D[4:0] Phone (0Ch) and MIC (0Eh)		Function
	WRITE	READBACK	
0	0 0000	0 0000	12 dB Gain
0	0 1000	0 1000	0 dB Gain
0	1 1111	1 1111	-34.5 dB Gain
1	x xxxx	x xxxx	-∞ dB Gain, Muted

x in the above table is a wild card, and has no effect on the value.

Line-In Volume Register (Index 10h)

Reg No.	Name	D15	D14	D13	D12	D11	D10	D9	D8	D7	D6	D5	D4	D3	D2	D1	D0	Default
10h	Line-In Volume	LVM	X	X	LLV4	LLV3	LLV2	LLV1	LLV0	RM*	X	X	RLV4	RLV3	RLV2	RLV1	RLV0	8808h

*For AC '97 compatibility, Bit D7 (RM) is available only by setting the MSPLT bit, Register 76h. The MSPLT bit enables separate mute bits for the left and right channels. If MSPLT is not set, the RM bit has no effect. All registers not shown, and bits containing an X are assumed to be reserved. Refer to Table IV for examples.

RLV[4:0]	Line-In Volume Right. Allows setting the line-in right channel attenuator in 32 volume levels. The LSB represents 1.5 dB, and the range is +12 dB to -34.5 dB. The default value is 0 dB, mute enabled.
RM	Right Channel Mute. Once enabled by the MSPLT bit in Register 76h, this bit mutes the right channel separately from the LM bit. Otherwise, this bit will always read 0 and will have no effect when set to 1.
LLV[4:0]	Line-In Volume Left. Allows setting the line in left channel attenuator in 32 volume levels. The LSB represents 1.5 dB, and the range is +12 dB to -34.5 dB. The default value is 0 dB, mute enabled.
LVM	Line-In Mute. When this bit is set to 1, both the left and right channels are muted unless the MSPLT bit in Register 76h is set to 1, in which case this mute bit will affect only the left channel.

CD Volume Register (Index 12h)

Reg No.	Name	D15	D14	D13	D12	D11	D10	D9	D8	D7	D6	D5	D4	D3	D2	D1	D0	Default
12h	CD Volume	CVM	X	X	LCV4	LCV3	LCV2	LCV1	LCV0	RM*	X	X	RCV4	RCV3	RCV2	RCV1	RCV0	8808h

*For AC '97 compatibility, Bit D7 (RM) is only available by setting the MSPLT bit, Register 76h. The MSPLT bit enables separate mute bits for the left and right channels. If MSPLT is not set, the RM bit has no effect. All registers not shown, and bits containing an X are assumed to be reserved. Refer to Table IV for examples.

RCV[4:0]	Right CD Volume. Allows setting the CD right channel attenuator in 32 volume levels. The LSB represents 1.5 dB, and the gain range is +12 dB to -34.5 dB. The default value is 0 dB, mute enabled.
RM	Right Channel Mute. Once enabled by the MSPLT bit in Register 76h, this bit mutes the right channel separately from the CVM bit. Otherwise, this bit will always read 0 and will have no affect when set to 1.
LCV[4:0]	Left CD Volume. Allows setting the CD left channel attenuator in 32 volume levels. The LSB represents 1.5 dB, and the gain range is +12 dB to -34.5 dB. The default value is 0 dB, mute enabled.
CVM	CD Volume Mute. When this bit is set to 1, both the left and right channels are muted, unless the MSPLT bit in Register 76h is set to 1, in which case this mute bit will affect only the left channel.

AD1981BL

AUX Volume Register (Index 16h)

Reg No.	Name	D15	D14	D13	D12	D11	D10	D9	D8	D7	D6	D5	D4	D3	D2	D1	D0	Default
16h	AUX Volume	AM	X	X	LAV4	LAV3	LAV2	LAV1	LAV0	RM*	X	X	RAV4	RAV3	RAV2	RAV1	RAV0	8808h

*For AC '97 compatibility, Bit D7 (RM) is available only by setting the MSPLT bit, Register 76h. The MSPLT bit enables separate mute bits for the left and right channels. If MSPLT is not set, RM bit has no effect. All registers not shown, and bits containing an X are assumed to be reserved. Refer to Table IV for examples.

RAV[4:0]	Right AUX Volume. Allows setting the AUX right channel attenuator in 32 volume levels. The LSB represents 1.5 dB, and the gain range is +12 dB to -34.5 dB. The default value is 0 dB, mute enabled.
RM	Right Channel Mute. Once enabled by the MSPLT bit in Register 76h, this bit mutes the right channel separately from the AM bit. Otherwise, this bit will always read 0 and will have no affect when set to 1.
LAV[4:0]	Left AUX Volume. Allows setting the AUX left channel attenuator in 32 volume levels. The LSB represents 1.5 dB, and the gain range is +12 dB to -34.5 dB. The default value is 0 dB, mute enabled.
AM	AUX Mute. When this bit is set to 1, both the left and right channels are muted, unless the MSPLT bit in Register 76h is set to 1, in which case this mute bit will affect only the left channel.

PCM-Out Volume Register (Index 18h)

Reg No.	Name	D15	D14	D13	D12	D11	D10	D9	D8	D7	D6	D5	D4	D3	D2	D1	D0	Default
18h	PCM-Out Volume	OM	X	X	LOV4	LOV3	LOV2	LOV1	LOV0	RM*	X	X	ROV4	ROV3	ROV2	ROV1	ROV0	8808h

*For AC '97 compatibility, Bit D7 (RM) is available only by setting the MSPLT bit, Register 76h. The MSPLT bit enables separate mute bits for the left and right channels. If MSPLT is not set, RM bit has no effect. All registers not shown, and bits containing an X are assumed to be reserved. Refer to Table IV for examples.

ROV[4:0]	Right PCM-Out Volume. Allows setting the PCM right channel attenuator in 32 volume levels. The LSB represents 1.5 dB, and the range is +12 dB to -34.5 dB. The default value is 0 dB, mute enabled.
RM	Right Channel Mute. Once enabled by the MSPLT bit in Register 76h, this bit mutes the right channel separately from the OM bit. Otherwise, this bit will always read 0 and will have no effect when set to 1.
LOV[4:0]	Left PCM-Out Volume. Allows setting the PCM left channel attenuator in 32 volume levels. The LSB represents 1.5 dB, and the range is +12 dB to -34.5 dB. The default value is 0 dB, mute enabled.
OM	PCM-Out Volume Mute. When this bit is set to 1, both the left and right channels are muted unless the MSPLT bit in Register 76h is set to 1, in which case this mute bit will affect only the left channel.

Table IV. Volume Settings for Line-In, CD Volume, AUX, and PCM-Out

Reg. 76h	Control Bits							
	Line-In (10h), CD (12h), AUX (16h), and PCM-Out (18h)							
	Left Channel Volume D[12:8]				Right Channel Volume D[4:0]			
MSPLT*	D15	Write	Readback	Function	D7*	Write	Readback	Function
0	0	0 0000	0 0000	12 dB Gain	x	0 0000	0 0000	+12 dB Gain
0	0	0 1000	0 1000	0 dB Gain	x	0 1000	0 1000	0 dB Gain
0	0	1 1111	1 1111	34.5 dB Gain	x	1 1111	1 1111	-34.5 dB Gain
0	1	x xxxx	x xxxx	-∞ dB Gain, Muted	x	x xxxx	x xxxx	-∞ dB Gain, Muted
1	0	1 1111	1 1111	-34.5 dB Gain	1	x xxxx	x xxxx	-∞ dB Gain, Right Only Muted
1	1	x xxxx	x xxxx	-∞ dB Gain, Left Only Muted	0	1 1111	1 1111	-34.5 dB Gain
1	1	x xxxx	x xxxx	-∞ dB Gain, Left Muted	1	x xxxx	x xxxx	-∞ dB Gain, Right Muted

*For AC '97 compatibility, Bit D7 (RM) is available only by setting the MSPLT bit, Register 76h. The MSPLT bit enables separate mute bits for the left and right channels. If MSPLT is not set, RM bit has no effect.

x in the above table is a wild card and has no effect on the value.

Record Select Control Register (Index 1Ah)

Reg No.	Name	D15	D14	D13	D12	D11	D10	D9	D8	D7	D6	D5	D4	D3	D2	D1	D0	Default
1Ah	Record Select	X	X	X	X	X	LS2	LS1	LS0	X	X	X	X	X	RS2	RS1	RS0	0000h

All registers not shown and bits containing an X are assumed to be reserved. Used to select the record source independently for right and left. The default value is 0000h, which corresponds to MIC In. Refer to Table V for examples.

RS[2:0]	Right Record Select
LS[2:0]	Left Record Select

Table V. Settings for Record Select Control

LS [10:8]	Left Record Source	RS [2:0]	Right Record Source
000	MIC	000	MIC
001	CD_L	001	CD_R
010	Muted	010	Muted
011	AUX_L	011	AUX_R
100	LINE_IN_L	100	LINE_IN_R
101	Stereo Mix (L)	101	Stereo Mix (R)
110	Mono Mix	110	Mono Mix
111	PHONE_IN	111	PHONE_IN

Record Gain Register (Index 1Ch)

Reg No.	Name	D15	D14	D13	D12	D11	D10	D9	D8	D7	D6	D5	D4	D3	D2	D1	D0	Default
1Ch	Record Gain	IM	X	X	X	LIM3	LIM2	LIM1	LIM0	RM*	X	X	X	RIM3	RIM2	RIM1	RIM0	8000h

*For AC '97 compatibility, Bit D7 (RM) is available only by setting the MSPLT bit, Register 76h. The MSPLT bit enables separate mute bits for the left and right channels. If MSPLT is not set, RM bit has no effect. All registers not shown and bits containing an X are assumed to be reserved. Refer to Table VI for examples.

RIM[3:0]	Right Input Mixer Gain Control. Each LSB represents 1.5 dB, 0000 = 0 dB, and the gain range is 0 dB to 22.5 dB.
RM	Right Channel Mute. Once enabled by the MSPLT bit in Register 76h, this bit mutes the right channel separately from the IM bit. Otherwise, this bit will always read 0 and will have no affect when set to 1.
LIM[3:0]	Left Input Mixer Gain Control. Each LSB represents 1.5 dB, 0000 = 0 dB, and the gain range is 0 dB to 22.5 dB.
IM	Input Mute. When this bit is set to 1, both the left and right channels are muted, unless the MSPLT bit in Register 76h is set to 1, in which case this mute bit will affect only the left channel.

Table VI. Settings for Record Gain Register

Reg. 76h	Control Bits—Record Gain (1Ch)							
	Left Channel Input Mixer D[11:8]				Right Channel Input Mixer D[3:0]			
MSPLT*	D15	Write	Readback	Function	D7*	Write	Readback	Function
0	0	1111	1111	22.5 dB Gain	x	1111	1111	22.5 dB Gain
0	0	0000	0000	0 dB Gain	x	0000	0000	0 dB Gain
0	1	xxxx	xxxx	-∞ dB Gain, Muted	x	xxxx	xxxx	-∞ dB Gain, Muted
1	0	1111	1111	22.5 dB Gain	1	xxxx	xxxx	-∞ dB Gain, Right Only Muted
1	1	xxxx	xxxx	-∞ dB Gain, Left Only Muted	0	1111	1111	22.5 dB Gain
1	1	xxxx	xxxx	-∞ dB Gain, Left Muted	1	xxxx	xxxx	-∞ dB Gain, Right Muted

*For AC '97 compatibility, Bit D7 (RM) is available only by setting the MSPLT bit, Register 76h. The MSPLT bit enables separate mute bits for the left and right channels. If MSPLT is not set, RM bit has no effect.

x is a wild card and has no effect on the value.

AD1981BL

General-Purpose Register (Index 20h)

Reg No.	Name	D15	D14	D13	D12	D11	D10	D9	D8	D7	D6	D5	D4	D3	D2	D1	D0	Default
20h	General-Purpose	X	X	X	X	X	X	MIX	MS	LPBK	X	X	X	X	X	X	X	0000h

This register should be read before writing to generate a mask for only the bit(s) that need to be changed. All registers not shown and bits containing an X are assumed to be reserved.

LPBK	<p>Loopback Control. ADC/DAC Digital Loopback Mode.</p> <p>0 = No Loopback (Default).</p> <p>1 = Loopback PCM Digital Data from ADC Output to DAC.</p>
MS	<p>MIC Select. Selects mono MIC input.</p> <p>0 = Select MIC1.</p> <p>1 = Select MIC2.</p> <p>See 2CMIC bit in Register 76h to enable stereo microphone recording.</p>
MIX	<p>Mono Output Select. Selects mono output audio source.</p> <p>0 = Mixer mono output (reset default).</p> <p>1 = MIC1 channel.</p>

Power-Down Control/Status Register (Index 26h)

Reg No.	Name	D15	D14	D13	D12	D11	D10	D9	D8	D7	D6	D5	D4	D3	D2	D1	D0	Default
26h	Power-Down Ctrl/Stat	EAPD	PR6	PR5	PR4	PR3	PR2	PR1	PR0	X	X	X	X	REF	ANL	DAC	ADC	000Xh

The ready bits are read-only; writing to REF, ANL, DAC, ADC will have no effect. These bits indicate the status for the AD1981BL subsections. If the bit is a 1, that subsection is *ready*. *Ready* is defined as the subsection able to perform in its nominal state. All registers not shown, and bits containing an X are assumed to be reserved.

ADC	ADC Sections Ready to Transmit Data.
DAC	DAC Sections Ready to Accept Data.
ANL	Analog Amplifiers, Attenuators, and Mixers Ready.
REF	Voltage References, V_{REF} and V_{REFOUT} up to Nominal Level.
PR [6:0]	<p>Codec Power-Down Modes. The first three bits are to be used individually rather than in combination with each other. PR3 can be used in combination with PR2 or by itself. The mixer and reference cannot be powered down via PR3 unless the ADCs and DACs are also powered down.</p> <p>Nothing else can be powered up until the reference is up. PR5 has no effect unless all ADCs, DACs, and the ac-link are powered down. The reference and the mixer can be either up or down, but all power-up sequences must be allowed to run to completion before PR5 and PR4 are both set.</p> <p>In multiple codec systems, the master codec's PR5 and PR4 bits control the slave codec. PR5 is also effective in the slave codec if the master's PR5 bit is clear, but the PR4 bit has no effect except to enable or disable PR5.</p>
EAPD	<p>External Audio Power-Down Control. Controls the state of the EAPD pin.</p> <p>EAPD = 0 sets the EAPD pin low, enabling an external power amplifier (reset default).</p> <p>EAPD = 1 sets the EAPD pin high, shutting the external power amplifier off.</p>

Power-Down State	Set Bits	PR [6:0]
ADCs and Input Mux Power-Down	PR0	[000 0001]
DACs Power-Down	PR1	[000 0010]
Analog Mixer Power-Down (V_{REF} and V_{REFOUT} On)	PR1, PR2	[000 0101]
Analog Mixer Power-Down (V_{REF} and V_{REFOUT} Off)	PR0, PR1, PR3	[000 1011]
AC-Link Interface Power-Down	PR4	[001 0000]
Internal Clocks Disabled	PR0, PR1, PR4, PR5	[011 0011]
ADC and DAC Power-Down	PR0, PR1	[000 0011]
V_{REF} Standby Mode	PR0, PR1, PR2, PR4, PR5	[011 0111]
Total Power-Down	PR0, PR1, PR2, PR3, PR4, PR5, PR6	[111 1111]
Headphone Amp Power-In Standby	PR6	[100 0000]

AD1981BL

Extended Audio ID Register (Index 28h)

Reg No.	Name	D15	D14	D13	D12	D11	D10	D9	D8	D7	D6	D5	D4	D3	D2	D1	D0	Default
28h	Ext'd Audio ID	IDC1	IDC0	X	X	REVC1	REVC0	AMAP	X	X	X	DSA1	DSA0	X	SPDIF	X	VRAS	X605h

The Extended Audio ID register identifies which extended audio features are supported. A nonzero Extended Audio ID value indicates that one or more of the extended audio features are supported. All registers not shown, and bits containing an X are assumed to be reserved.

VRAS	Variable Rate PCM Audio Support (Read-Only). This bit returns a 1 when Read To indicates that the variable rate PCM audio is supported.
SPDIF	SPDIF Support (Read-Only). This bit returns a 1 when Read To indicates that the SPDIF transmitter is supported (IEC958). This bit is also used to validate that the SPDIF transmitter output is actually enabled. The SPDIF bit is allowed to be set high only if the SPDIF pin (48) is pulled down at power-up, enabling the codec transmitter logic. If the SPDIF pin is floating or pulled high at power-up, the transmitter logic is disabled; therefore, this bit returns a low, indicating that the SPDIF transmitter is not available. This bit must always be read back to verify that the SPDIF transmitter is actually enabled.
DSA[1,0]	DAC Slot Assignments (Read/Write) (Reset Default = 00). 00 DACs 1, 2 = 3 and 4. 01 DACs 1, 2 = 7 and 8. 10 DACs 1, 2 = 6 and 9. 11 Reserved.
AMAP	Slot DAC Mappings Based on Codec ID (Read-Only). This bit returns a 1 when read to indicate that slot/DAC mappings based on the codec ID are supported.
REVC[1,0]	REVC[1,0] = 01 indicates codec is AC '97 revision 2.2 compliant (Read-Only).
IDC[1:0]	Indicates Codec Configuration (Read-Only). 00 = Primary. 01, 10, 11 = Secondary.

Extended Audio Status and Control Register (Index 2Ah)

Reg No.	Name	D15	D14	D13	D12	D11	D10	D9	D8	D7	D6	D5	D4	D3	D2	D1	D0	Default
2Ah	Ext'd Audio Stat/Ctrl	VFORCE	X	X	X	X	SPCV	X	X	X	X	SPSA1	SPSA0	X	SPDIF	X	VRA	0000h

All registers not shown and bits containing an X are assumed to be reserved. The Extended Audio Status and Control register is a read/write register that provides status and control of the extended audio features.

VRA	Variable Rate Audio (Read/Write). VRA = 0 sets fixed sample rate audio at 48 kHz (reset default). VRA = 1 enables variable rate audio mode (enables sample rate registers and SLOTREQ signaling).
SPDIF	SPDIF Transmitter Subsystem Enable/Disable Bit (Read/Write). SPDIF = 1 enables the SPDIF transmitter. SPDIF = 0 disables the SPDIF transmitter (default). This bit is also used to validate that the SPDIF transmitter output is actually enabled. The SPDIF bit is allowed to be set high only if the SPDIF pin (48) is pulled down at power-up, enabling the codec transmitter logic. If the SPDIF pin is floating or pulled high at power-up, the transmitter logic is disabled and this bit therefore returns a low, indicating that the SPDIF transmitter is not available. This bit must always be read back to verify that the SPDIF transmitter is actually enabled.
SPSA[1:0]	SPDIF Slot Assignment Bits (Read/Write). These bits control the SPDIF slot assignment and respective defaults, depending on the codec ID configuration.
SPCV	SPDIF Configuration Valid (Read-Only). Indicates the status of the SPDIF transmitter subsystem, enabling the driver to determine if the currently programmed SPDIF configuration is supported. SPCV is always valid, independent of the SPDIF enable bit status. SPCV = 0 indicates current SPDIF configuration (SPSA, SPSR, DAC slot rate, DRS) is not valid (not supported). SPCV = 1 indicates current SPDIF configuration (SPSA, SPSR, DAC slot rate, DRS) is valid (is supported).
VFORCE	Validity Force Bit (Reset Default = 0). When asserted, this bit forces the SPDIF stream Validity flag (Bit 28 within each SPDIF L/R subframe) to be controlled by the V bit (D15) in Register 3Ah (SPDIF control register). VFORCE = 0 and V = 0; the Validity bit is managed by the codec error detection logic. VFORCE = 0 and V = 1; the Validity bit is forced high, indicating subframe data is invalid. VFORCE = 1 and V = 0; the Validity bit is forced low, indicating subframe data is valid. VFORCE = 1 and V = 1; the Validity bit is forced high, indicating subframe data is invalid.

AD1981BL

AC '97 2.2 AMAP Compliant Default SPDIF Slot Assignments

Codec ID	Function	SPSA = 00	SPSA = 01	SPSA = 10	SPSA = 11
00	2-Ch Primary w/SPDIF	3 and 4	7 and 8 (default)	6 and 9	10 and 11
00	4-Ch Primary w/SPDIF	3 and 4	7 and 8	6 and 9 (default)	10 and 11
00	6-Ch Primary w/SPDIF	3 and 4	7 and 8	6 and 9	10 and 11 (default)
01	+2-Ch Secondary w/SPDIF	3 and 4	7 and 8	6 and 9 (default)	
01	+4-Ch Secondary w/SPDIF	3 and 4	7 and 8	6 and 9	10 and 11 (default)
10	+2-Ch Secondary w/SPDIF	3 and 4	7 and 8	6 and 9 (default)	
10	+4-Ch Secondary w/SPDIF	3 and 4	7 and 8	6 and 9	10 and 11 (default)
11	+2-Ch Secondary w/SPDIF	3 and 4	7 and 8	6 and 9	10 and 11 (default)

PCM Front DAC Rate Register (Index 2Ch)

Reg No.	Name	D15	D14	D13	D12	D11	D10	D9	D8	D7	D6	D5	D4	D3	D2	D1	D0	Default
2Ch	PCM Front DAC Rate	SRF15	SRF14	SRF13	SRF12	SRF11	SRF10	SRF9	SRF8	SRF7	SRF6	SRF5	SRF4	SRF3	SRF2	SRF1	SRF0	BB80h

This read/write sample rate control register contains a 16-bit unsigned value, representing the rate of operation in Hz.

SRF[15:0]	Sample Rate. The sampling frequency range is from 7 kHz (1B58h) to 48 kHz (BB80h) in 1 Hz increments. If 0 is written to VRA, the sample rate is reset to 48 kHz.
-----------	---

PCM ADC Rate Register (Index 32h)

Reg No.	Name	D15	D14	D13	D12	D11	D10	D9	D8	D7	D6	D5	D4	D3	D2	D1	D0	Default
32h	PCM L/R ADC Rate	SRA15	SRA14	SRA13	SRA12	SRA11	SRA10	SRA9	SRA8	SRA7	SRA6	SRA5	SRA4	SRA3	SRA2	SRA1	SRA0	BB80h

This read/write sample rate control register contains 16-bit unsigned value, representing the rate of operation in Hz.

SRA[15:0]	Sample Rate. The sampling frequency range is from 7 kHz (1B58h) to 48 kHz (BB80h) in 1 Hz increments. If 0 is written to VRA, the sample rate is reset to 48 kHz.
-----------	---

SPDIF Control Register (Index 3Ah)

Reg No.	Name	D15	D14	D13	D12	D11	D10	D9	D8	D7	D6	D5	D4	D3	D2	D1	D0	Default
3Ah	SPDIF Control	V	X	SPSR1	SPSR0	L	CC6	CC5	CC4	CC3	CC2	CC1	CC0	PRE	COPY	$\overline{\text{AUD}}$	PRO	2000h

Register 3Ah is a read/write register that controls SPDIF functionality and manages bit fields propagated as channel status (or subframe in the V case). With the exception of V, this register should be written to only when the SPDIF transmitter is disabled (SPDIF bit in Register 2Ah is 0). This ensures that control and status information start up correctly at the beginning of SPDIF transmission.

PRO	Professional. 1 indicates professional use of channel status. 0 indicates consumer.
$\overline{\text{AUD}}$	Non-Audio. 1 indicates data is non-PCM format. 0 data is PCM.
COPY	Copyright. 1 indicates copyright is asserted. 0 copyright is not asserted.
PRE	Pre-Emphasis. 1 indicates filter pre-emphasis is 50 μ s/15 μ s. 0 pre-emphasis is none.
CC[6:0]	Category Code. Programmed according to IEC standards, or as appropriate.
L	Generation Level. Programmed according to IEC standards, or as appropriate.
SPSR[1:0]	SPDIF Transmit Sample Rate. SPSR[1:0] = 00 Transmit sample rate = 44.1 kHz. SPSR[1:0] = 01 Reserved. SPSR[1:0] = 10 Transmit sample rate = 48 kHz (reset default). SPSR[1:0] = 11 Not supported.
V	Validity. This bit affects the validity flag (Bit 28 transmitted in each SPDIF L/R subframe) and enables the SPDIF transmitter to maintain connection during error or mute conditions. V = 1 Each SPDIF subframe (L + R) has Bit 28 set to 1. This tags both samples as invalid. V = 0 Each SPDIF subframe (L + R) has Bit 28 set to 0 for valid data and 1 for invalid data (error condition). Note that when V = 0, asserting the VFORCE bit (D15) in Register 2Ah (Ext'd Audio Stat/Ctrl) will force the Validity flag low, marking both samples as valid.

AD1981BL

EQ Control Register (Index 60h)

Reg No.	Name	D15	D14	D13	D12	D11	D10	D9	D8	D7	D6	D5	D4	D3	D2	D1	D0	Default
60h	EQ CTRL	EQM	MAD LBEN	X	X	X	X	X	X	SYM	CHS	BCA5	BCA4	BCA3	BCA2	BCA1	BCA0	8080h

Register 60h is a read/write register that controls the equalizer functionality and data setup. This register also contains the Biquad and Coefficient Address pointer, which is used in conjunction with the EQ Data Register (78h) to set up the equalizer coefficients. The reset default disables the equalizer function until the coefficients can be properly set up by the software and sets the Symmetry bit to allow equal coefficients for left and right channels. All registers not shown and bits containing an X are assumed to be reserved.

BCA[5,0]	<p>Biquad and Coefficient Address Pointer</p> <p>biquad 0 coef a0 BCA[5,0] = 011011</p> <p>biquad 0 coef a1 BCA[5,0] = 011010</p> <p>biquad 0 coef a2 BCA[5,0] = 011001</p> <p>biquad 0 coef b1 BCA[5,0] = 011101</p> <p>biquad 0 coef b2 BCA[5,0] = 011100</p> <p>biquad 1 coef a0 BCA[5,0] = 100000</p> <p>biquad 1 coef a1 BCA[5,0] = 011111</p> <p>biquad 1 coef a2 BCA[5,0] = 011110</p> <p>biquad 1 coef b1 BCA[5,0] = 100010</p> <p>biquad 1 coef b2 BCA[5,0] = 100001</p> <p>biquad 2 coef a0 BCA[5,0] = 100101</p> <p>biquad 2 coef a1 BCA[5,0] = 100100</p> <p>biquad 2 coef a2 BCA[5,0] = 100011</p> <p>biquad 2 coef b1 BCA[5,0] = 100111</p> <p>biquad 2 coef b2 BCA[5,0] = 100110</p> <p>biquad 3 coef a0 BCA[5,0] = 101010</p> <p>biquad 3 coef a1 BCA[5,0] = 101001</p> <p>biquad 3 coef a2 BCA[5,0] = 101000</p> <p>biquad 3 coef b1 BCA[5,0] = 101100</p> <p>biquad 3 coef b2 BCA[5,0] = 101011</p> <p>biquad 4 coef a0 BCA[5,0] = 101111</p> <p>biquad 4 coef a1 BCA[5,0] = 101110</p> <p>biquad 4 coef a2 BCA[5,0] = 101101</p> <p>biquad 4 coef b1 BCA[5,0] = 110001</p> <p>biquad 4 coef b2 BCA[5,0] = 110000</p> <p>biquad 5 coef a0 BCA[5,0] = 110100</p> <p>biquad 5 coef a1 BCA[5,0] = 110011</p> <p>biquad 5 coef a2 BCA[5,0] = 110010</p> <p>biquad 5 coef b1 BCA[5,0] = 110110</p> <p>biquad 5 coef b2 BCA[5,0] = 110101</p> <p>biquad 6 coef a0 BCA[5,0] = 111001</p> <p>biquad 6 coef a1 BCA[5,0] = 111000</p> <p>biquad 6 coef a2 BCA[5,0] = 110111</p> <p>biquad 6 coef b1 BCA[5,0] = 111011</p> <p>biquad 6 coef b2 BCA[5,0] = 111010</p>
CHS	<p>Channel Select.</p> <p>CHS = 0 selects left channel coefficients data block.</p> <p>CHS = 1 selects right channel coefficients data block.</p>
SYM	<p>Symmetry. When set to 1, this bit indicates that the left and right channel coefficients are equal. This shortens the coefficients' setup sequence since only the left channel coefficients need to be addressed and set up (the right channel coefficients are fetched from the left channel memory).</p>
MAD LBEN	<p>Mixer ADC Loopback Enable. Enables mixer ADC data to be summed into PCM stream.</p> <p>0 = No loopback allowed (default).</p> <p>1 = Enable loopback.</p>
EQM	<p>Equalizer Mute. When set to 1, this bit disables the equalizer function (allows all data to pass through). The reset default sets this bit to 1, disabling the equalizer function until the biquad coefficients can be properly set.</p>

EQ Data Register (Index 62h)

Reg No.	Name	D15	D14	D13	D12	D11	D10	D9	D8	D7	D6	D5	D4	D3	D2	D1	D0	Default
62h	EQ DATA	CFD15	CFD14	CFD13	CFD12	CFD11	CFD10	CFD9	CFD8	CFD7	CFD6	CFD5	CFD4	CFD3	CFD2	CFD1	CFD0	0000h

This read/write register is used to transfer EQ biquad coefficients into memory. The register data is transferred to, or retrieved from, the address pointed to by the BCA bits in the EQ CNTRL Register (60h). Data will be written to memory only if the EQM bit (Register 60h, Bit 15) is asserted.

CFD[15:0]	Coefficient Data. The biquad coefficients are fixed point format values with 16 bits of resolution. The CFD15 bit is the MSB, and the CFD0 bit is the LSB.
-----------	--

Mixer ADC, Input Gain Register (Index 64h)

Reg No.	Name	D15	D14	D13	D12	D11	D10	D9	D8	D7	D6	D5	D4	D3	D2	D1	D0	Default
64h	Mixer Volume	MXM	X	X	X	LMG3	LMG2	LMG1	LMG0	RM*	X	X	X	RMG3	RMG2	RMG1	RMG0	8000h

*For AC '97 compatibility, Bit D7 (RM) is available only by setting the MSPLT bit, Register 76h. The MSPLT bit enables separate mute bits for the left and right channels. If MSPLT is not set, the RM bit has no effect. All registers not shown and bits containing an X are assumed to be reserved. Refer to Table VII for examples.

RMG[3:0]	Right Mixer Gain Control. This register controls the gain into the mixer ADC from 0 dB to a maximum gain of 22.5 dB. The least significant bit represents 1.5 dB.
RM	Right Channel Mute. Once enabled by the MSPLT bit in Register 76h, this bit mutes the right channel separately from the MXM bit. Otherwise, this bit will always read 0 and will have no affect when set to 1.
LMG[3:0]	Left Mixer Gain Control. This register controls the gain into the mixer ADC, from 0 dB to a maximum gain of 22.5 dB. The least significant bit represents 1.5 dB.
MXM	Mixer Gain Register Mute. 0 = Unmuted. 1 = Muted (reset default).

Table VII. Settings for Mixer ADC, Input Gain

Reg. 76h	Control Bits Mixer ADC, Input Gain (64h)								
	Left Channel Mixer Gain D[11:8]				Right Channel Mixer Gain D[3:0]				
	MSPLT*	D15	Write	Readback	Function	D7*	Write	Readback	Function
	0	0	1111	1111	22.5 dB Gain	x	1111	1111	22.5 dB Gain
	0	0	0000	0000	0 dB Gain	x	0000	0000	0 dB Gain
	0	1	xxxx	xxxx	-∞ dB Gain, Muted	x	xxxx	xxxx	-∞ dB Gain, Muted
	1	0	1111	1111	22.5 dB Gain	1	xxxx	xxxx	-∞ dB Gain, Right Only Muted
	1	1	xxxx	xxxx	-∞ dB Gain, Left Only Muted	0	1111	1111	22.5 dB Gain
	1	1	xxxx	xxxx	-∞ dB Gain, Left Muted	1	xxxx	xxxx	-∞ dB Gain, Right Muted

*For AC '97 compatibility, Bit D7 (RM) is available only by setting the MSPLT bit, Register 76h. The MSPLT bit enables separate mute bits for the left and right channels. If MSPLT is not set, RM bit has no effect.

x is a wild card and has no effect on the value.

AD1981BL

Jack Sense/Audio Interrupt/Status Register (Index 72h)

Reg No.	Name	D15	D14	D13	D12	D11	D10	D9	D8	D7	D6	D5	D4	D3	D2	D1	D0	Default
72h	Jack Sense	X	X	X	JS MT2	JS MT1	JS MT0	JS1 EQB	JS0 EQB	JS1 TMR	JS0 TMR	JS1 MD	JS0 MD	JS1 ST	JS0 ST	JS1 INT	JS0 INT	0000h

All register bits are read/write except for JS0ST and JS1ST, which are read-only. All registers not shown and bits containing an X are assumed to be reserved.

JS0INT	Indicates Pin JS0 Has Generated an Interrupt. Remains set until the software services JS0 interrupt, i.e., JS0 ISR should clear this bit by writing a 0 to it. Note that the interrupt to the system is actually an OR combination of this bit and JS1INT. Also note that the actual interrupt implementation is selected by the INTS bit (Register 76h). It is also possible to generate a software system interrupt by writing a 1 to this bit.
JS1INT	Indicates Pin JS1 Has Generated an Interrupt. Remains set until the software services JS1 interrupt, i.e., JS1 ISR should clear this bit by writing a 0 to it. See JS0INT description for additional details.
JS0ST	JS0 State. This bit always reports the logic state of JS0 pin.
JS1ST	JS1 State. This bit always reports the logic state of JS1 pin.
JS0MD	JS0 Mode. This bit selects the operation mode for the JS0 pin. 0 = Jack Sense mode (default). 1 = Interrupt mode.
JS1MD	JS1 Mode. This bit selects the operation mode for the JS1 pin. 0 = Jack Sense mode (default). 1 = Interrupt mode.
JS0TMR	JS0 Timer Enable. If this bit is set to a 1, JS0 must be high for greater than 278 ms to be recognized.
JS1TMR	JS1 Timer Enable. If this bit is set to a 1, JS1 must be high for greater than 278 ms to be recognized.
JS0EQB	JS0 EQ Bypass Enable. This bit enables JS0 to control the EQ bypass. When this bit is set to 1, JS0 = 1 will cause the EQ to be bypassed.
JS1EQB	JS1 EQ Bypass Enable. This bit enables JS1 to control the EQ bypass. When this bit is set to 1, JS1 = 1 will cause the EQ to be bypassed.
JSMT[2,0]	JS Mute Enable Selector. These three bits select and enable the Jack Sense muting action (see Table VIII).

Table VIII. Jack Sense Mute Select-JSMT [2:0]

REF	JS1 Headphone	JS0 Line Out	JSMT2	JSMT1	JSMT0	H.P. Out	Line Out	Mono Out	Notes
0	OUT (0)	OUT (0)	0	0	0	ACTIVE	ACTIVE	ACTIVE	JS0 and JS1 Ignored.
1	OUT (0)	IN (1)	0	0	0	ACTIVE	ACTIVE	ACTIVE	
2	IN (1)	OUT (0)	0	0	0	ACTIVE	ACTIVE	ACTIVE	
3	IN (1)	IN (1)	0	0	0	ACTIVE	ACTIVE	ACTIVE	
4	OUT (0)	OUT (0)	0	0	1	FMUTE	FMUTE	ACTIVE	JS0 No Mute Action; JS1 Mutes Line_Out.
5	OUT (0)	IN (1)	0	0	1	FMUTE	ACTIVE	ACTIVE	
6	IN (1)	OUT (0)	0	0	1	ACTIVE	FMUTE	ACTIVE	
7	IN (1)	IN (1)	0	0	1	ACTIVE	FMUTE	ACTIVE	
8	OUT (0)	OUT (0)	0	1	0	FMUTE	FMUTE	ACTIVE	JS0 No Mute Action; JS1 Mutes Mono and Line_Out.
9	OUT (0)	IN (1)	0	1	0	FMUTE	ACTIVE	ACTIVE	
10	IN (1)	OUT (0)	0	1	0	ACTIVE	FMUTE	FMUTE	
11	IN (1)	IN (1)	0	1	0	ACTIVE	FMUTE	FMUTE	
12	OUT (0)	OUT (0)	0	1	1	**	**	**	** Reserved
13	OUT (0)	IN (1)	0	1	1	**	**	**	
14	IN (1)	OUT (0)	0	1	1	**	**	**	
15	IN (1)	IN (1)	0	1	1	**	**	**	
16	OUT (0)	OUT (0)	1	0	0	FMUTE	FMUTE	ACTIVE	JS0 Mutes Mono; JS1 No Mute Action.
17	OUT (0)	IN (1)	1	0	0	FMUTE	ACTIVE	FMUTE	
18	IN (1)	OUT (0)	1	0	0	ACTIVE	FMUTE	ACTIVE	
19	IN (1)	IN (1)	1	0	0	ACTIVE	ACTIVE	FMUTE	
20	OUT (0)	OUT (0)	1	0	1	FMUTE	FMUTE	ACTIVE	JS0 Mutes Mono; JS1 Mutes Line_Out.
21	OUT (0)	IN (1)	1	0	1	FMUTE	ACTIVE	FMUTE	
22	IN (1)	OUT (0)	1	0	1	ACTIVE	FMUTE	ACTIVE	
23	IN (1)	IN (1)	1	0	1	ACTIVE	FMUTE	FMUTE	
24	OUT (0)	OUT (0)	1	1	0	FMUTE	FMUTE	ACTIVE	JS0 Mutes Mono; JS1 Mutes Mono and Line_Out.
25	OUT (0)	IN (1)	1	1	0	FMUTE	ACTIVE	FMUTE	
26	IN (1)	OUT (0)	1	1	0	ACTIVE	FMUTE	FMUTE	
27	IN (1)	IN (1)	1	1	0	ACTIVE	FMUTE	FMUTE	
28	OUT (0)	OUT (0)	1	1	1	**	**	**	** Reserved
29	OUT (0)	IN (1)	1	1	1	**	**	**	
30	IN (1)	OUT (0)	1	1	1	**	**	**	
31	IN (1)	IN (1)	1	1	1	**	**	**	

FMUTE = Output is forced to mute independent of the respective volume register setting.

ACTIVE = Output is not muted and its status is dependent on the respective volume register setting.

OUT = Nothing plugged into the jack and therefore the JS status is low (via the load resistor pull-down).

IN = Jack has plug inserted and therefore the JS status is high (via the codec JS internal pull-up).

AD1981BL

Serial Configuration Register (Index 74h)

Reg No.	Name	D15	D14	D13	D12	D11	D10	D9	D8	D7	D6	D5	D4	D3	D2	D1	D0	Default
74h	Serial Configuration	SLOT16	REGM2	REGM1	REGM0	X	X	X	CHEN	X	X	X	INTS	X	SPAL	SPDZ	SPLNK	7001h

This register is not reset when the reset register (Register 00h) is written. All registers not shown and bits containing an X are assumed to be reserved.

SPLNK	SPDIF Link. This bit enables the SPDIF to link with the DAC for data requesting. 0 = SPDIF and DAC are not linked. 1 = SPDIF and DAC are linked and receive the same data requests (reset default).
SPDZ	SPDIF DACZ. 0 = Repeat last sample out of the SPDIF stream if FIFO underruns (reset default). 1 = Forces midscale sample out the SPDIF stream if FIFO underruns.
SPAL	SPDIF ADC Loop-Around. 0 = SPDIF transmitter is connected to the ac-link stream (reset default). 1 = SPDIF transmitter is connected to the digital ADC stream, not the ac-link.
INTS	Interrupt Mode Select. This bit selects the JS interrupt implementation path. 0 = Bit 0 SLOT 12 (modem interrupt). 1 = Slot 6 valid bit (MIC ADC interrupt).
CHEN	Chain Enable. This bit enables chaining of a slave codec SDATA_IN stream into the ID0 pin (Pin 45). 0 = Disable chaining (reset default). 1 = Enable chaining into ID0 pin.
REGM0	Master Codec Register Mask.
REGM1	Slave 1 Codec Register Mask.
REGM2	Slave 2 Codec Register Mask.
SLOT16	Enable 16-Bit Slot Mode. SLOT16 makes all ac-link slots 16 bits in length, formatted into 16 slots. This is a preferred mode for DSP serial port interfacing.

Miscellaneous Control Bit Register (Index 76h)

Reg No.	Name	D15	D14	D13	D12	D11	D10	D9	D8	D7	D6	D5	D4	D3	D2	D1	D0	Default
76h	Misc Control Bits	DACZ	X	MSPLT	LODIS	DAM	X	FMXE	X	MADPD	2CMIC	X	MADST	VREFH	VREFD	MBG1	MBG0	0000h

All registers not shown and bits containing an X are assumed to be reserved.

MBG[1:0]	MIC Boost Gain Change Register. These two bits allow changing the MIC preamp gain from the nominal 20 dB gain. Note: This gain setting takes affect only while Bit D6 (M20) on the MIC volume register (0Eh) is set to 1; otherwise, the MIC boost block has a gain of 0 dB. 00 = 20 dB gain (reset default). 01 = 10 dB gain. 10 = 30 dB gain. 11 = Reserved.
VREFD	V_{REFOUT} Disable. Disables V_{REFOUT} , placing it into High Z Out mode. Note that this bit overrides the VREFH bit selection (see below). 0 = V_{REFOUT} pin is driven by the internal reference (reset default). 1 = V_{REFOUT} pin is placed into High Z Out mode.
VREFH	V_{REFOUT} High. Changes V_{REFOUT} from 2.25 V to 3.70 V for MIC bias applications. 0 = V_{REFOUT} pin is set to 2.25 V output (reset default). 1 = V_{REFOUT} pin is set to 2.25 V output.

MADST	Mixer ADC Status Bit. Indicates status of mixer digitizing ADC (left and right channels). 0 = Mixer ADC not ready. 1 = Mixer ADC ready.
MADPD	Mixer ADC Power-Down. Controls power down for mixer digitizing ADC. 0 = Mixer ADC is powered on (default). 1 = Mixer ADC is powered down.
2CMIC	2-Channel MIC Select. This bit enables simultaneous recording from MIC1 and MIC2 inputs for applications that use a stereo microphone array. Note that this register works in conjunction with the MS bit in Register 20h. 0 = MIC1 or MIC2 (determined by MS bit) is routed to the record selector's left and right MIC channels as well as to the mixer (reset default). 1 = MIC1 is routed to the record selector's left MIC channel and MIC2 is routed to the record selector's right MIC channel. Note that in this mode, the MS bit should be set low and MIC1 can still be enabled into the mixer.
FMXE	Front DAC into Mixer Enable. Controls the front (main) DAC to mixer mute switches. 0 = Front DAC outputs are allowed to sum into the mixer (reset default). 1 = Front DAC outputs are muted into the mixer (blocked).
DAM	Digital Audio Mode. PCM DAC outputs bypass the analog mixer and are sent directly to the codec output.
LODIS	LINE_OUT Disable. Disables the LINE_OUT pins (L/R), placing them into High Z mode so that the assigned output audio jack can be shared for input function (or other function). 0 = LINE_OUT pins have normal audio drive capability (reset default). 1 = LINE_OUT pins are placed into High Z mode.
MSPLT	Mute Split. Allows separate mute control bits for Master, Headphone, LINE_IN, CD, AUX, and PCM volume control registers as well as record gain register. 0 = Both left and right channel mutes are controlled by Bit 15 in the respective registers (reset default). 1 = Bit 15 affects only the left channel mute and Bit 7 affects only the right channel mute.
DACZ	DAC Zero-Fill. Determines DAC data fill under starved conditions. 0 = DAC data is repeated when DACs are starved for data (reset default). 1 = DAC is zero-filled when DACs are starved for data.

Vendor ID Register (Index 7Ch to 7Eh)

Reg No.	Name	D15	D14	D13	D12	D11	D10	D9	D8	D7	D6	D5	D4	D3	D2	D1	D0	Default
7Ch	Vendor ID1	F7	F6	F5	F4	F3	F2	F1	F0	S7	S6	S5	S4	S3	S2	S1	S0	4144h

S[7:0] This register is ASCII encoded to A.

F[7:0] This register is ASCII encoded to D.

Reg No.	Name	D15	D14	D13	D12	D11	D10	D9	D8	D7	D6	D5	D4	D3	D2	D1	D0	Default
7Eh	Vendor ID2	T7	T6	T5	T4	T3	T2	T1	T0	REV7	REV6	REV5	REV4	REV3	REV2	REV1	REV0	5374h

T[7:0] This register is ASCII encoded to S.

REV[7:0] Vendor specific revision number: The AD1981BL assigns 74h to this field.

Table IX. Codec ID and External Clock Selection Table

ID1	ID0	Codec ID	Codec Clocking Source
1	1	(00) Primary	24.576 MHz (Local Xtal or External into XTL_IN)
1	0	(01) Secondary	12.288 MHz (External into BIT_CLK)
0	1	(00) Primary	48.000 MHz (External into XTL_IN)
0	0	(00) Primary	14.31818 MHz (External into XTL_IN)

Note that internally, the \overline{ID} pins have weak pull-ups and are inverted.

OUTLINE DIMENSIONS

48-Lead Low Profile Quad Flat Package [LQFP]
(ST-48)

Dimensions shown in millimeters

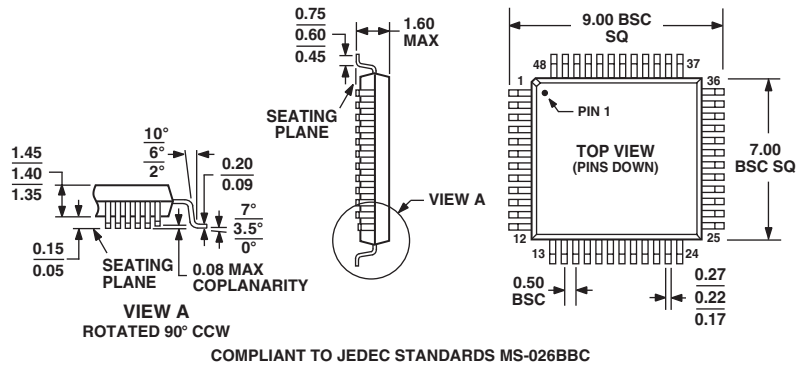

D04321-0-1/04(0)



LittleDiode supplies new, hard to find or obsolete electronic components and semiconductors all over the world.

With over two million different components listed you are sure to find the part you need.

Feel free to visit us today at our online store:

LittleDiode.com

Looking forward to providing you with the best possible service.