



High-Side Bi-directional Current Shunt Monitor

Preliminary Technical Data

AD8210

FEATURES

High common-mode voltage range

- 2 V to +65 V operating
- 5 V to +68 V survival

Gain = 20

Wide operating temperature range

- Die: -40°C to +150°C
- 8-lead SOIC: -40°C to +125°C

Adjustable offset

Available in SOIC and die form

EXCELLENT AC AND DC PERFORMANCE

- 5 $\mu\text{V}/^\circ\text{C}$ offset drift
- 30 ppm/ $^\circ\text{C}$ gain drift
- 80 dB CMRR dc to 10 kHz

APPLICATIONS

- 42V DC/DC Converter Current Sensing
- High Side Current Sensing
- Motor controls
- Transmission controls
- Diesel injection controls
- Engine management
- Suspension controls
- Vehicle dynamic controls

GENERAL DESCRIPTION

The AD8210 is a high-side, single-supply, bi-directional current shunt monitor featuring a wide input common mode voltage range of -2V to 65V, high bandwidth, set gain of 20, and a typical supply voltage of 5V.

The AD8210 is offered in die and packaged form. The operating temperature range for the die is 25°C higher (up to 150°C) than that of the packaged part to enable the user to apply the AD8210 in high temperature applications.

Rev. PrA

Information furnished by Analog Devices is believed to be accurate and reliable. However, no responsibility is assumed by Analog Devices for its use, nor for any infringements of patents or other rights of third parties that may result from its use. Specifications subject to change without notice. No license is granted by implication or otherwise under any patent or patent rights of Analog Devices. Trademarks and registered trademarks are the property of their respective owners.

FUNCTIONAL BLOCK DIAGRAM

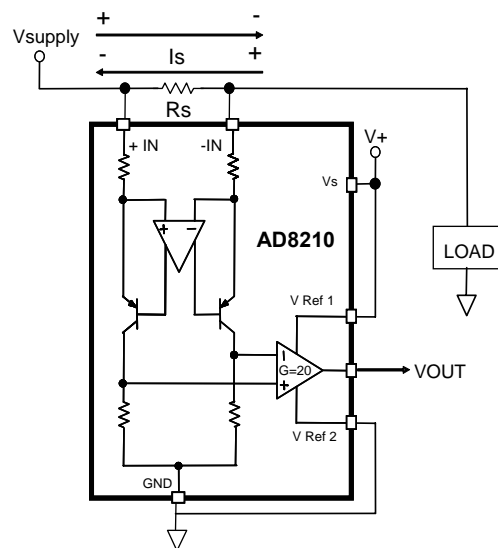

Figure 1: Typical Operating Circuit

Excellent AC and DC performance over temperature keeps errors in the measurement loop to a minimum. Offset drift is typically below 5 $\mu\text{V}/^\circ\text{C}$, and the Gain drift is typically below 30ppm/ $^\circ\text{C}$.

Bi-directional current measurement is achieved by offsetting the output between 0.05V and 4.8V with a 5V supply. With the $V_{\text{REF}2}$ pin connected to the V+ pin, and $V_{\text{REF}1}$ pin connected to GND pin, the output is set at half scale. Attaching both V_{REF} pins to GND causes the output to be unipolar, starting near ground. Attaching both V_{REF} pins to V+ cause the output to be

unipolar starting near V_+ . Other offsets can be obtained by applying an external voltage to V_{REF1} and V_{REF2} pins.

Specifications

T_A = Operating Temperature Range, $V_S=5V$, unless otherwise noted

Parameter	Conditions	AD8210 SOIC			AD8210 DIE			Unit
		Min	Typ	Max	Min	Typ	Max	
GAIN								
Gain			20		20			V/V
Accuracy	$V_O \geq 0.1V$ DC		± 0.5	± 1	± 0.5	± 1.5		%
Accuracy Over Temperature	Specified Temperature Range			± 1.5		± 2.5		%
Gain vs. Temperature			± 30		± 50			ppm/ $^{\circ}C$
VOLTAGE OFFSET								
Offset Voltage (RTI)	$25^{\circ}C$			± 1		± 2		mV
Over Temperature (RTI)	Specified Temperature Range			± 2		± 4		mV
Offset Drift			5		10			$\mu V/^{\circ}C$
INPUT								
Input Impedance								
Differential			2		2			k Ω
Common Mode	V common mode $> 5V$		5		5			M Ω
Common Mode	V common mode $< 5V$		3.5		3.5			k Ω
Input Voltage Range	Common-Mode, Continuous	-2		65	-2		65	V
Input Voltage Range	Differential, Uni-directional		250		250			mV
Input Voltage Range	Differential		± 125		± 125			mV
Common-Mode Rejection	$f = 1$ kHz	80						dB
Common-Mode Rejection	$f = 10$ kHz ¹	80			80			dB
OUTPUT								
Output Voltage Range		0.05		4.8	0.05		4.8	V
DYNAMIC RESPONSE								
Small Signal -3 dB Bandwidth			400		400			kHz
Slew Rate			3		3			V/ μs
NOISE								
0.1 Hz to 10 Hz, RTI			TBD		TBD			μV p-p
Spectral Density, 1 kHz, RTI			TBD		TBD			$\mu V/\sqrt{Hz}$
OFFSET ADJUSTMENT								
Offset Adjustment Range	$V_S = 5V$	0.05		4.8	0.05		4.8	V
POWER SUPPLY								
Operating Range	For Specified Performance	4.5		5.5	4.5		5.5	V
Quiescent Current Over Temp	$V_O = 0.1V$ dc		0.5	1.5		0.5	1.5	mA
Power Supply Rejection Ratio		80			80			dB
Temperature Range								
For Specified Performance	Operating Temperature Range	-40		+125	-40 $^{\circ}C$		+150	$^{\circ}C$

ABSOLUTE MAXIMUM RATINGS

Table 1.

Parameter	Rating
Supply Voltage	12.5 V
Continuous Input Voltage	65V
Transient Input Voltage	72V
Reverse Supply Voltage	-0.3 V
Negative Common Mode Range	-2.3V
Operating Temperature Range	-40°C to +125°C
Storage Temperature	-65 to +150°C
Lead Temperature Range	300°C

Stresses above those listed under Absolute Maximum Ratings may cause permanent damage to the device. This is a stress rating only and functional operation of the device at these or any other conditions above those indicated in the operational section of this specification is not implied. Exposure to absolute maximum rating conditions for extended periods may affect device reliability.

ESD CAUTION

ESD (electrostatic discharge) sensitive device. Electrostatic charges as high as 4000 V readily accumulate on the human body and test equipment and can discharge without detection. Although this product features proprietary ESD protection circuitry, permanent damage may occur on devices subjected to high energy electrostatic discharges. Therefore, proper ESD precautions are recommended to avoid performance degradation or loss of functionality.



OUTPUT OFFSET ADJUSTMENT

The output of the AD8210 can be adjusted for unidirectional or bidirectional operation.

UNIDIRECTIONAL OPERATION

Unidirectional operation allows the AD8210 to measure currents through a resistive shunt in one direction. The basic modes for unidirectional operation are ground referenced output mode and V+ referenced output mode.

In the case of unidirectional operation, the output could be set at the negative rail (near ground) or at the positive rail (near V+) when the differential input is 0 V. The output moves to the opposite rail when a correct polarity differential input voltage is applied. In this case, full scale is approximately 250 mV. The required polarity of the differential input depends on the output voltage setting. If the output is set at the positive rail, the input polarity needs to be negative to move the output down. If the output is set at ground, the polarity is positive to move the output up.

GROUND REFERENCED OUTPUT

When using the AD8210 in this mode, both reference inputs are tied to ground, which causes the output to sit at the negative rail when there are zero differential volts at the input (see Figure 2).

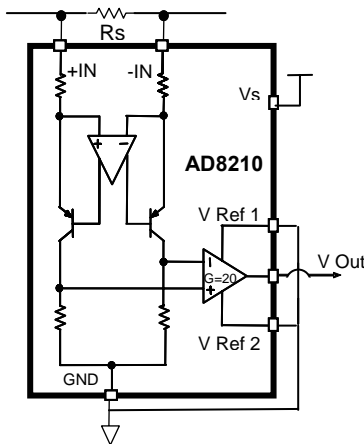

Figure 2. Ground Referenced Output

Table 2. V+ = 5 V

V _{IN} (Referred to -IN)	V _O
0 V	0.05 V
250 mV	4.8 V

V+ REFERENCED OUTPUT

This mode is set when both reference pins are tied to the positive supply. It is typically used when the diagnostic scheme requires detection of the amplifier and the wiring before power is applied to the load (see Figure 3).

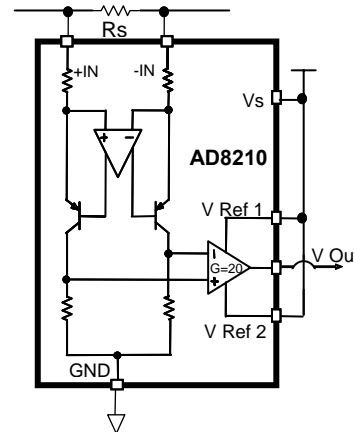

Figure 3. V+ Referenced Output

Table 3. V+ = 5 V

V _{IN} (Referred to -IN)	V _O
0 V	4.8 V
250 mV	0.05 V

BIDIRECTIONAL OPERATION

Bidirectional operation allows the AD8210 to measure currents through a resistive shunt in two directions.

In this case, the output is set anywhere within the output range. Typically, it is set at half-scale for equal range in both directions. In some cases, however, it is set at a voltage other than half-scale when the bidirectional current is nonsymmetrical.

Table 4. V+ = 5 V, V_O = 2.5 with V_{IN} = 0 V

V _{IN} (Referred to -IN)	V _O
+100 mV	4.5 V
-100 mV	0.5 V

Adjusting the output is accomplished by applying voltage(s) to the reference inputs.

V_{REF1} and V_{REF2} are tied to internal resistors that connect to an internal offset node. There is no operational difference between the pins

EXTERNAL REFERENCE OUTPUT

Tying both pins together and to a reference produces an output at the reference voltage when there is no differential input (see Figure 4). The output moves down from the reference voltage when the input is negative relative to the -IN pin and up when the input is positive relative to the -IN pin.

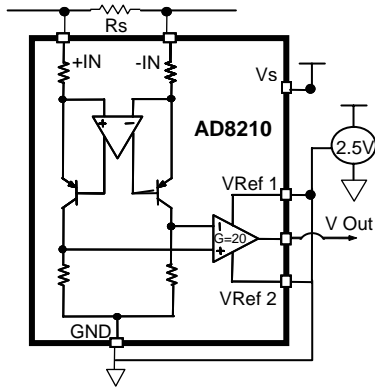

Figure 4. External Reference Output

SPLITTING AN EXTERNAL REFERENCE

In this case, an external reference is divided by 2 with an accuracy of approximately 0.5% by connecting one VREF pin to ground and the other VREF pin to the reference (see Figure 5).

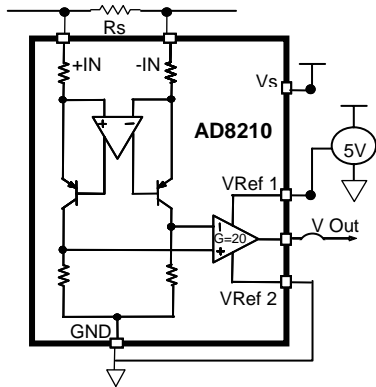

Figure 5: Split External Reference

SPLITTING THE SUPPLY

By tying one reference pin to V+ and the other to the ground pin, the output is set at half of the supply when there is no differential input (see Figure 6). The benefit is that no external reference is required to offset the output for bidirectional current measurement. This creates a midscale offset that is ratiometric to the supply, which means that if the supply increases or decreases, the output remains at half the supply. For example, if the supply is 5.0 V, the output is at half scale or 2.5 V. If the supply increases by 10% (to 5.5 V), the output goes to 2.75 V.

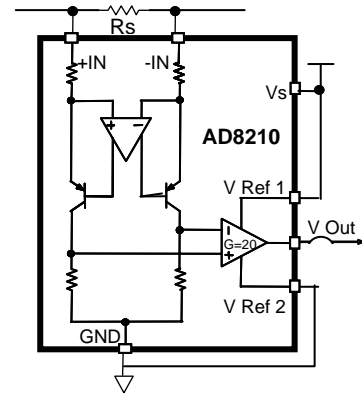

Figure 6: Split Supply

APPLICATIONS

A typical application for the AD8210 is high-side measurement of a current through a solenoid for PWM control of the solenoid opening. Typical applications include hydraulic transmission control and diesel injection control.

Two typical circuit configurations are used for this type of application.

HIGH-SIDE CURRENT SENSE WITH A LOW-SIDE SWITCH

In this case, the PWM control switch is ground referenced. An inductive load (solenoid) is tied to a power supply. A resistive shunt is placed between the switch and the load (see Figure 7). An advantage of placing the shunt on the high side is that the entire current, including the re-circulation current, can be measured since the shunt remains in the loop when the switch is off. In addition, diagnostics can be enhanced because shorts to ground can be detected with the shunt on the high side.

In this circuit configuration, when the switch is closed, the common-mode voltage moves down to near the negative rail. When the switch is opened, the voltage reversal across the inductive load causes the common-mode voltage to be held one diode drop above the battery by the clamp diode.

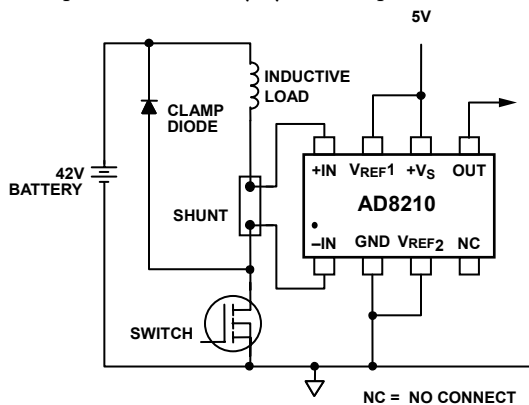

Figure 7. Low-Side Switch

HIGH-SIDE CURRENT SENSE WITH A HIGH-SIDE SWITCH

This configuration minimizes the possibility of unexpected solenoid activation and excessive corrosion (see Figure 8). In this case, both the switch and the shunt are on the high side. When the switch is off, this removes the battery from the load, which prevents damage from potential shorts to ground, while still allowing the recirculation current to be measured and providing for diagnostics. Removing the power supply from the load for the majority of the time minimizes the corrosive effects that could be caused by the differential voltage between the load and ground.

When using a high-side switch, the battery voltage is connected to the load when the switch is closed, causing the common-mode voltage to increase to the battery voltage. In this case, when the switch is opened, the voltage reversal across the inductive load causes the common-mode voltage to be held one diode drop below ground by the clamp diode.

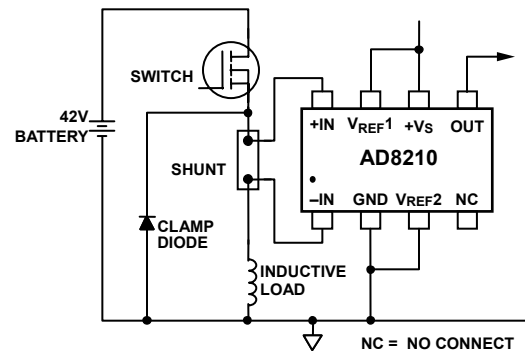

Figure 8. High-Side Switch

Another typical application for the AD8210 is as part of the control loop in H-bridge motor control. In this case, the AD8210 is placed in the middle of the H-bridge (see Figure 9) so that it can accurately measure current in both directions by using the shunt available at the motor. This is a better solution than a ground referenced op amp because ground is not typically a stable reference voltage in this type of application. This instability in the ground reference causes the measurements that could be made with a simple ground referenced op amp to be inaccurate.

The AD8210 measures current in both directions as the H-bridge switches and the motor changes direction. The output of the AD8210 is configured in an external reference bidirectional mode, see the Output Offset Adjustment section.

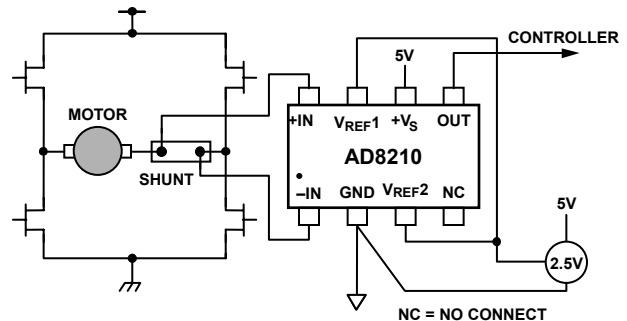
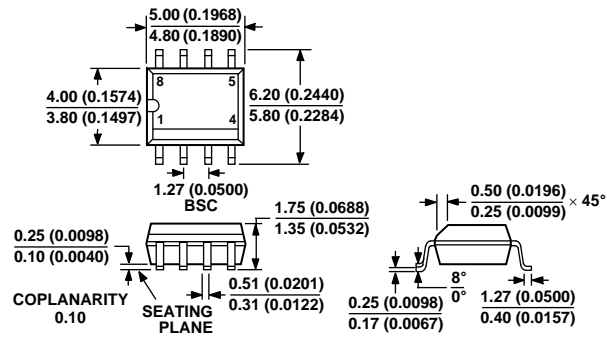

Figure 9. Motor Control Application

OUTLINE DIMENSIONS



COMPLIANT TO JEDEC STANDARDS MS-012AA
 CONTROLLING DIMENSIONS ARE IN MILLIMETERS; INCH DIMENSIONS
 (IN PARENTHESES) ARE ROUNDED-OFF MILLIMETER EQUIVALENTS FOR
 REFERENCE ONLY AND ARE NOT APPROPRIATE FOR USE IN DESIGN

Figure 10. 8-Lead Standard Small Outline Package [SOIC]
 Narrow Body
 (R-8)
 Dimensions shown in millimeters and (inches)



LittleDiode supplies new, hard to find or obsolete electronic components and semiconductors all over the world.

With over two million different components listed you are sure to find the part you need.

Feel free to visit us today at our online store:

LittleDiode.com

Looking forward to providing you with the best possible service.