



Am53CF94/Am53CF96

Enhanced SCSI-2 Controller (ESC)

DISTINCTIVE CHARACTERISTICS

- Pin/function compatible with Emulex FAS216/236
- AMD's Patented programmable GLITCH EATER™ Circuitry on \overline{REQ} and \overline{ACK} inputs
- 10 Mbytes/s synchronous Fast SCSI transfer rate
- 20 Mbytes/s DMA transfer rate
- 16-Bit DMA interface plus 2 bits of parity
- Flexible three bus architecture
- Single-ended SCSI bus supported by Am53CF94
- Differential SCSI bus supported by Am53CF96
- Selection of multiplexed or non-multiplexed address and data bus
- High current drivers (48 mA) for direct connection to the single-ended SCSI bus
- Supports Disconnect and Reselect commands
- Supports burst mode DMA operation with a threshold of eight
- Supports 3-byte tagged-queueing as per the SCSI-2 specification
- Supports group 2 and 5 command recognition as per the SCSI-2 specification
- Advanced CMOS process for lower power consumption
- AMD's exclusive programmable power-down feature
- 24-Bit extended transfer counter allows for data block transfer of up to 16 Mbytes
- Independently programmable 3-byte message and group 2 identification
- Additional check for ID message during bus-initiated Select with \overline{ATN}
- Reselection has QTAG features of $\overline{ATN3}$
- Access FIFO Command
- Delayed enable signal for differential drivers avoid contention on SCSI differential lines
- Programmable Active Negation on \overline{REQ} , \overline{ACK} and Data lines
- Register programmable control of assertion/deassertion delay for \overline{REQ} and \overline{ACK} lines
- Part-unique ID code
- Am53CF94 available in 84-pin PLCC package
- Am53CF96 available in 100-pin PQFP package
- Am53CF94 available in 3.3 V version
- Supports clock operating frequencies from 10 MHz–40 MHz
- Supports Scatter-Gather or Back-to-Back synchronous data transfers

GENERAL DESCRIPTION

The Enhanced SCSI-2 Controller (ESC) was designed to support Fast SCSI-2 transfer rates of up to 10 Mbytes/s in synchronous mode and up to 7 Mbytes/s in the asynchronous mode. The ESC is downward compatible with the Am53C94/96, combining its functionality with features such as Fast SCSI, programmable Active Negation, a 24-bit transfer counter, and a part-unique ID code containing manufacturer and serial # information. AMD's proprietary features such as power-down mode for SCSI transceivers, programmable GLITCH EATER, and extended Target command set are also included for improved product performance.

The Enhanced SCSI-2 Controller (ESC) has a flexible three bus architecture. The ESC has a 16-bit DMA interface, an 8-bit host data interface and an 8-bit SCSI data interface. The ESC is designed to minimize host intervention by implementing common SCSI sequences in hardware. An on-chip state machine reduces protocol overheads by performing the required sequences in response to a single command from the host. Selection,

reselection, information transfer and disconnection commands are directly supported.

The 16-byte-internal FIFO further assists in minimizing host involvement. The FIFO provides a temporary storage for all command, data, status and message bytes as they are transferred between the 16-bit host data bus and the 8-bit SCSI data bus. During DMA operations the FIFO acts as a buffer to allow greater latency in the DMA channel. This permits the DMA channel to be suspended for higher priority operations such as DRAM refresh or reception of an ISDN packet.

Parity on the DMA bus is optional. Parity can either be generated and checked or it can be simply passed through.

The Target command set for the Am53CF94/96 includes an additional command, the Access FIFO command, to allow the host or DMA controller to remove remaining FIFO data following the host's issuance of a Target abort DMA command or following an abort due to

parity error. This command facilitates data recovery and thereby minimizes the need to re-transmit data.

AMD's exclusive power-down feature can be enabled to help reduce power consumption during the chip's sleep mode. The receivers on the SCSI bus may be turned off to eliminate current that may flow because termination power (~3 V) is close to the trip point of the input buffers.

The patented GLITCH EATER Circuitry in the Enhanced SCSI-2 Controller can be programmed to filter glitches with widths up to 35 ns. It is designed to dramatically increase system reliability by detecting and

removing glitches that may cause system failure. The GLITCH EATER Circuitry is implemented on the \overline{ACK} and \overline{REQ} lines since they are most susceptible to electrical anomalies such as reflections and voltage spikes. Such signal inconsistencies can trigger false $\overline{REQ}/\overline{ACK}$ handshaking, false data transfers, addition of random data, and double clocking. AMD's GLITCH EATER Circuitry therefore maintains system performance and improves reliability. The following diagram illustrates this circuit's operation.

The Am53CF94 is also available in a 3.3 V version.

GLITCH EATER Circuitry in SCSI Environment

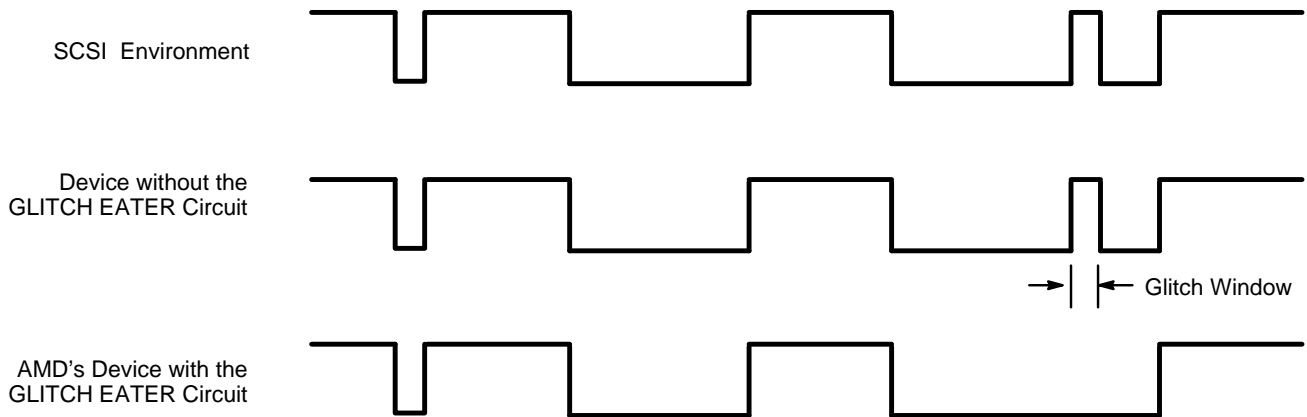

Note:

The Glitch Window is programmable via Control Register Four (0DH), bits 6 & 7. Window may be set to 35 ns (max). Default setting is 12 ns (single-ended).

17348B-1

SYSTEM BLOCK DIAGRAM

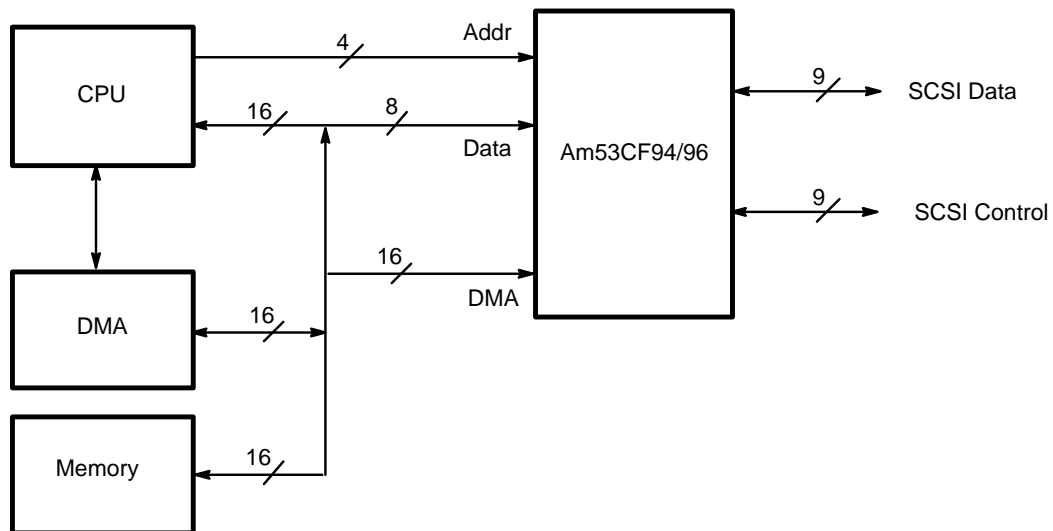

17348B-2

SYSTEM BUS MODE DIAGRAMS

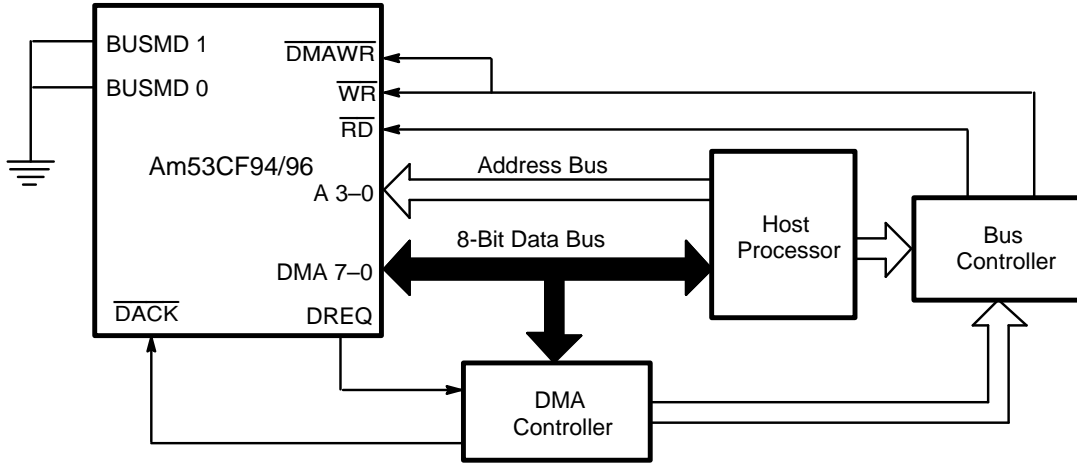

Bus Mode 0

17348B-3

Single Bus Architecture: 8-Bit DMA, 8-Bit Processor

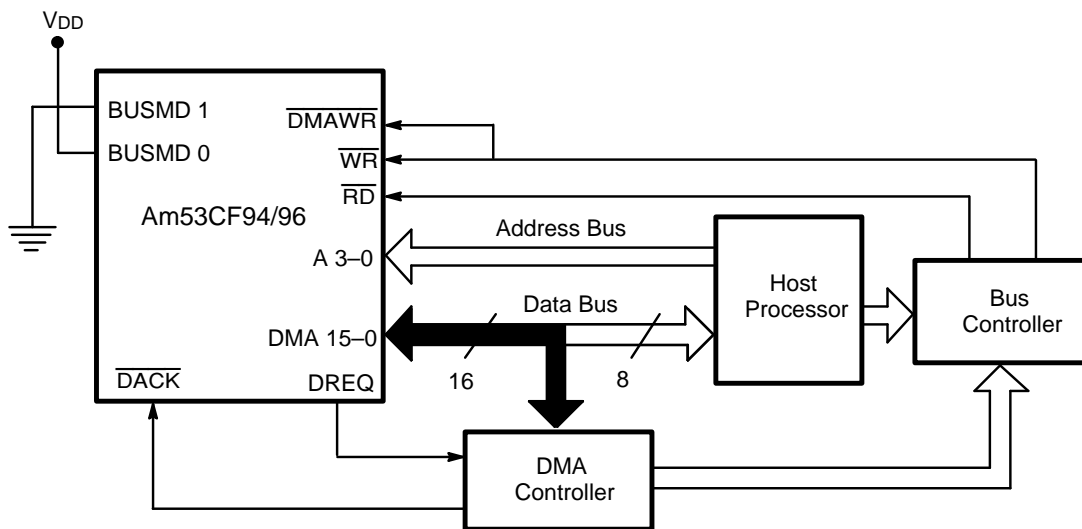

Bus Mode 1

17348B-4

Single Bus Architecture: 16-Bit DMA, 8-Bit Processor

SYSTEM BUS MODE DIAGRAMS

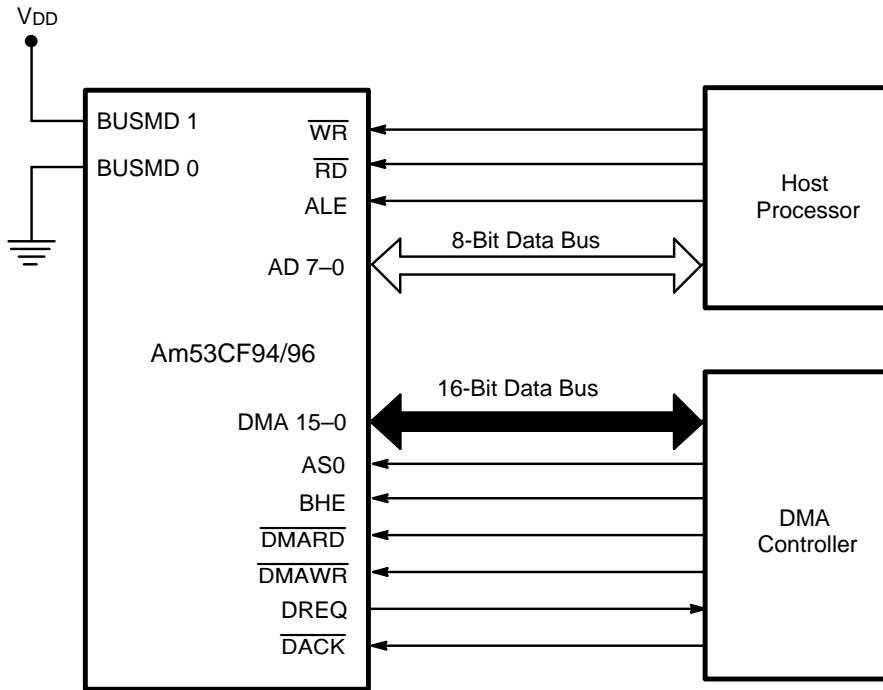

Bus Mode 2

17348B-5

Dual Bus Architecture: 16-Bit DMA with Byte Control, 8-Bit Multiplexed Processor Address Data

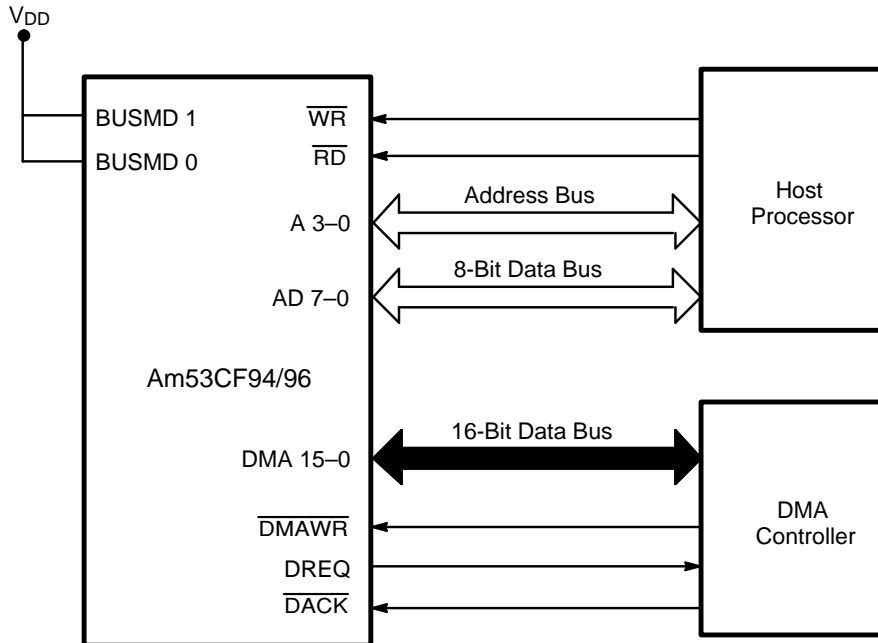

Bus Mode 3

17348B-6

Dual Bus Architecture: 16-Bit DMA, 8-Bit Processor

BLOCK DIAGRAM

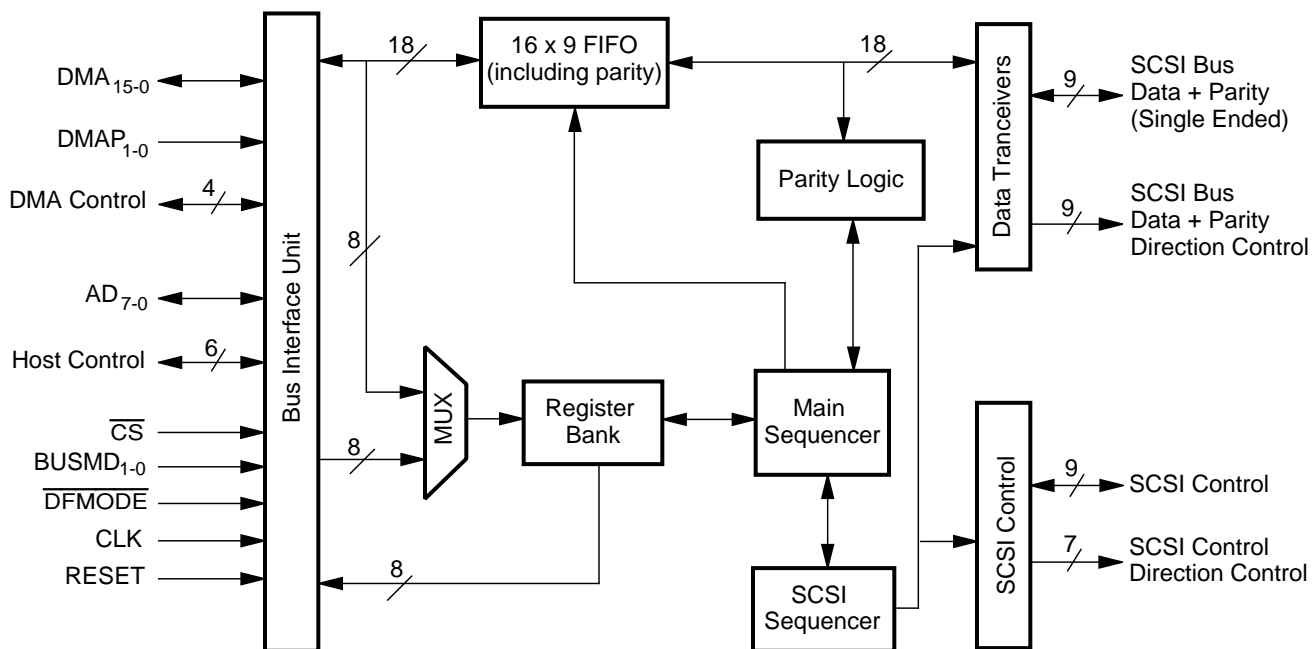

17348B-7

CONNECTION DIAGRAMS

Top View

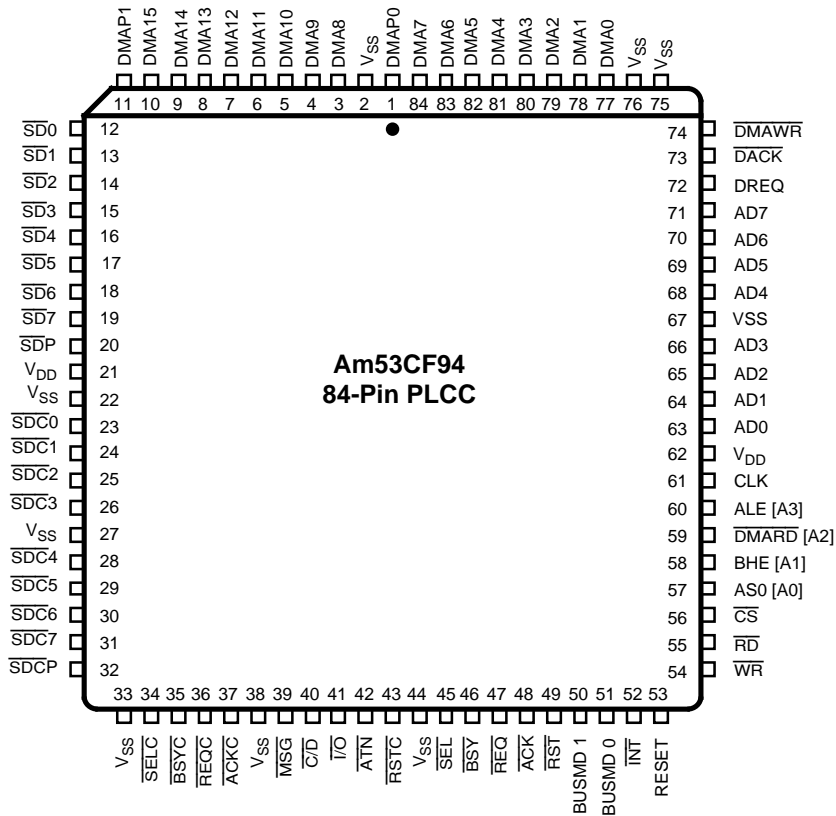

17348B-8

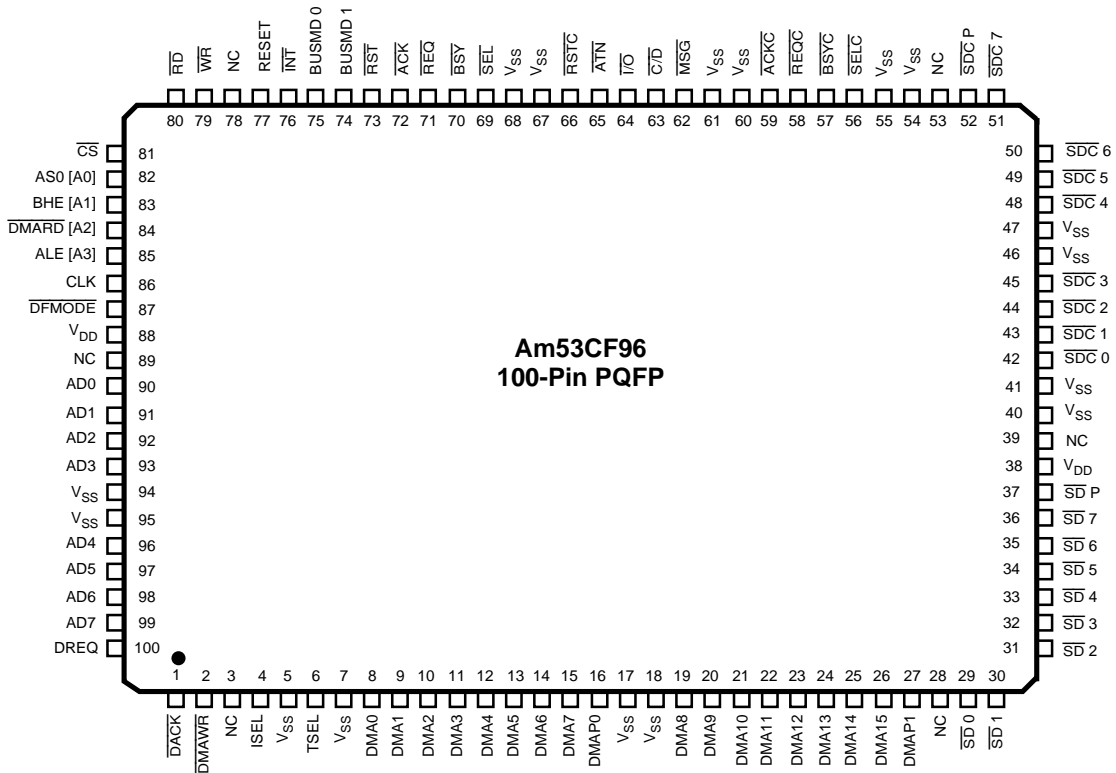

17348B-9

LOGIC SYMBOL

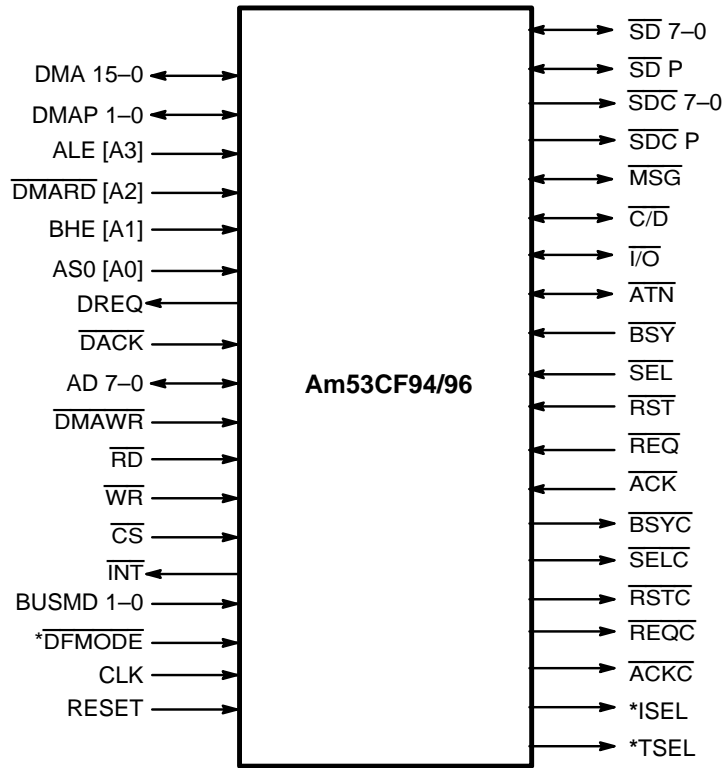

Note:

*Pins available on the Am53CF96 only.

17348B-10

RELATED AMD PRODUCTS

Part Number	Description	Part Number	Description
85C30	Enhanced Serial Communication Controller	Am386™	High-Performance 32-Bit Microprocessor
26LSXX	Line Drivers/Receivers	53C80A	SCSI Bus Controller
33C93A	Enhanced CMOS SCSI Bus Interface Controller	80188	Highly Integrated 8-Bit Microprocessor
80C186	Highly Integrated 16-Bit Microprocessor	85C80	Combination 53C80A SCSI and 85C30 ESCC
80C286 80286	High-Performance 16-Bit Microprocessor	53C94LV	Low Voltage, High Performance SCSI Controller

ORDERING INFORMATION

Standard Products

AMD standard products are available in several packages and operating ranges. The order number (Valid Combination) is formed by a combination of:

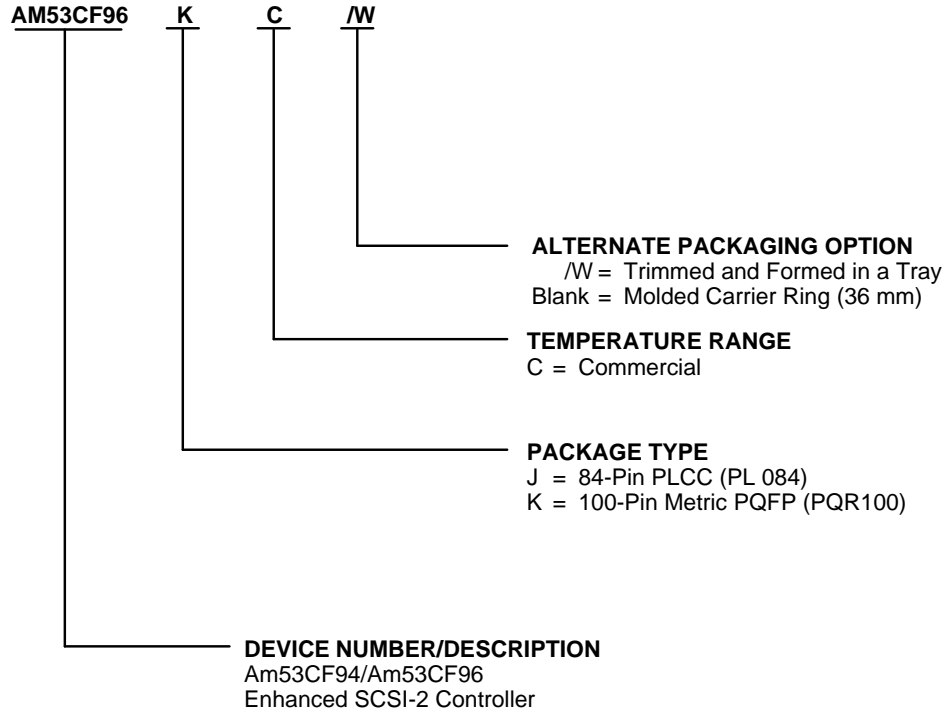

Valid Combinations	
AM53CF94	JC
AM53CF96	KC, KC/W

Valid Combinations

Valid Combinations list configurations planned to be supported in volume for this device. Consult the local AMD sales office to confirm availability of specific valid combinations or to check on newly released combinations.

SCSI OUTPUT CONNECTIONS

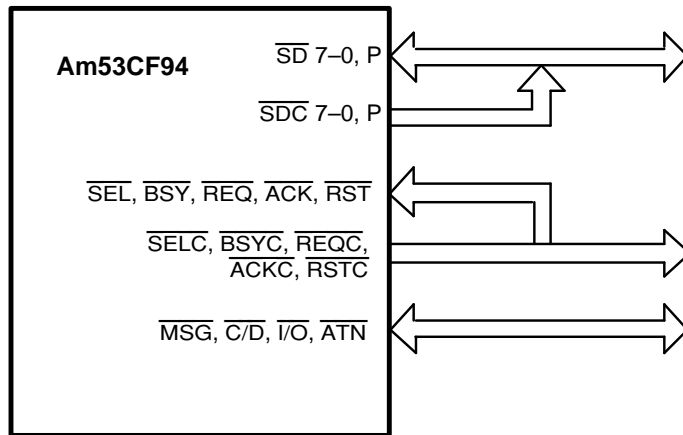

17348B-11

Am53CF94 Single Ended SCSI Bus Configuration

SCSI OUTPUT CONNECTIONS

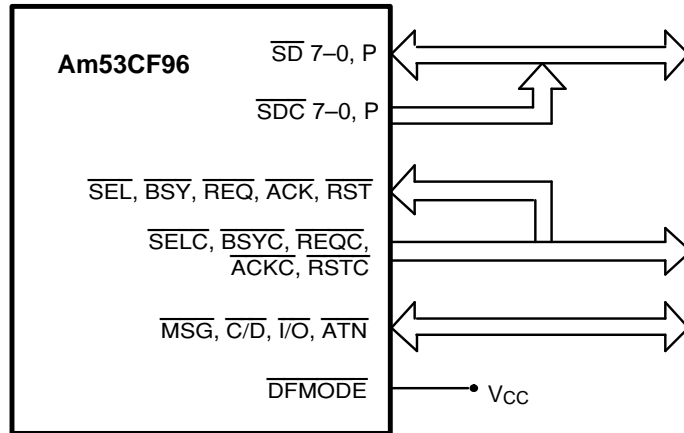

17348B-12

Am53CF96 Single Ended SCSI Bus Configuration

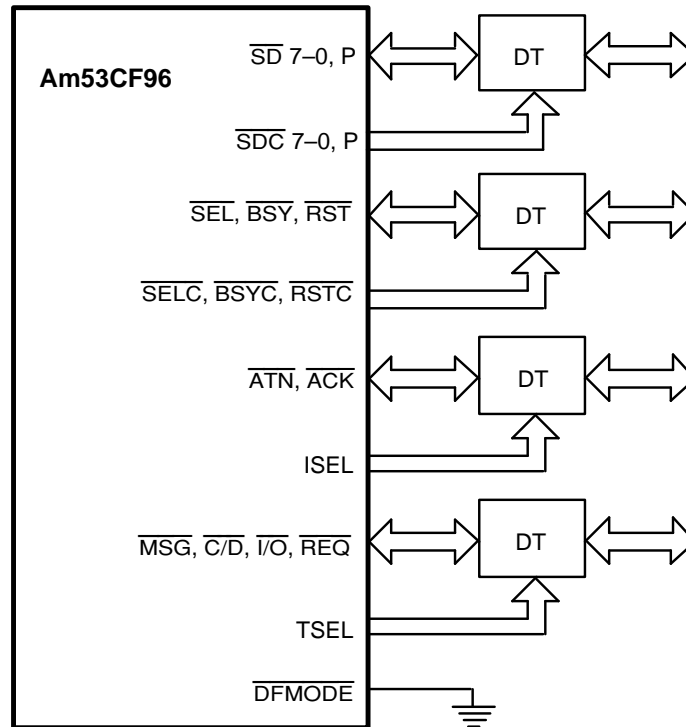

17348B-13

Am53CF96 Differential SCSI Bus Configuration

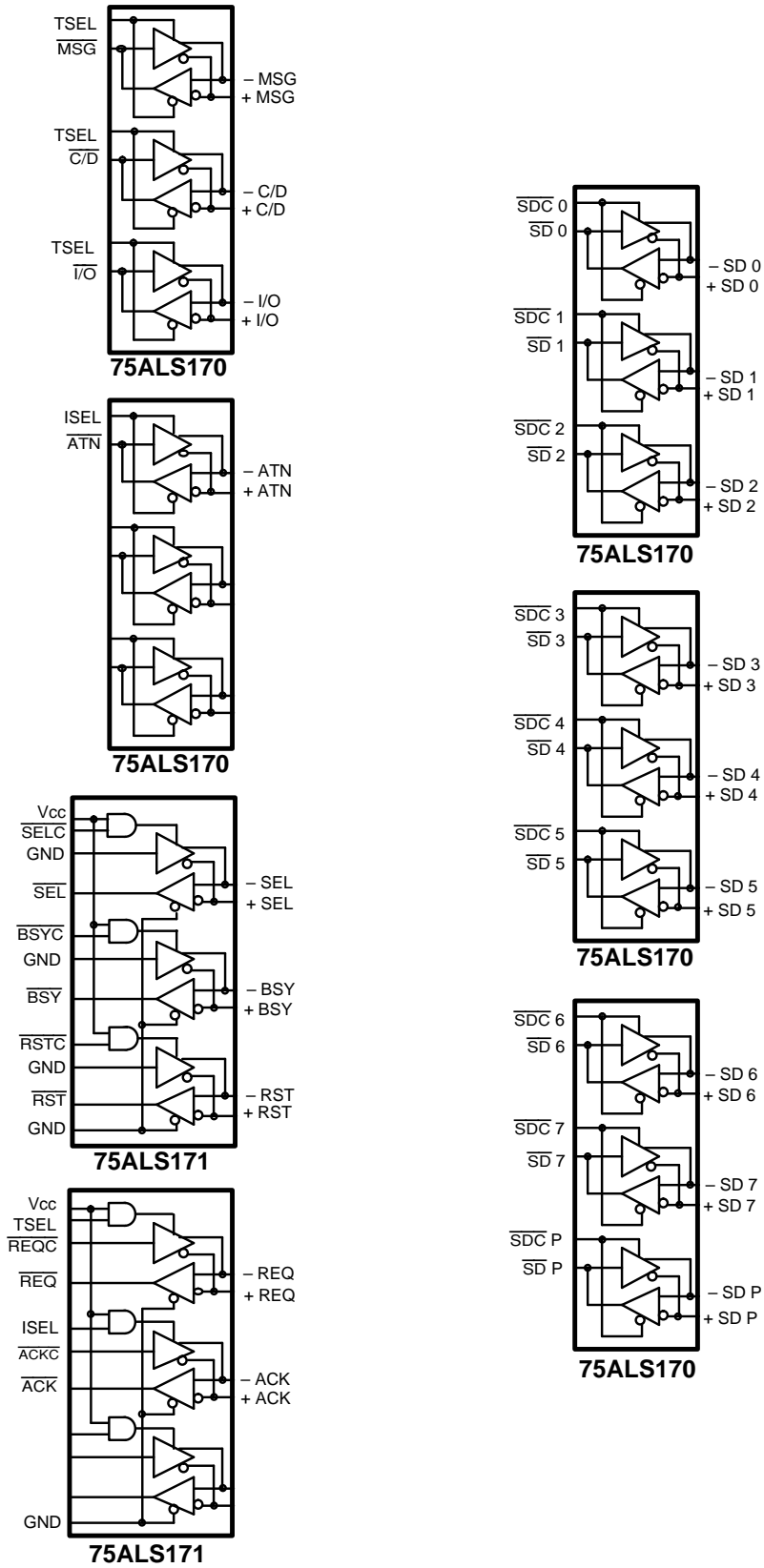

17348B-14

Differential Transceiver Connections for the Differential SCSI Bus Configuration Using 75ALS170 and 75ALS171 Transceivers

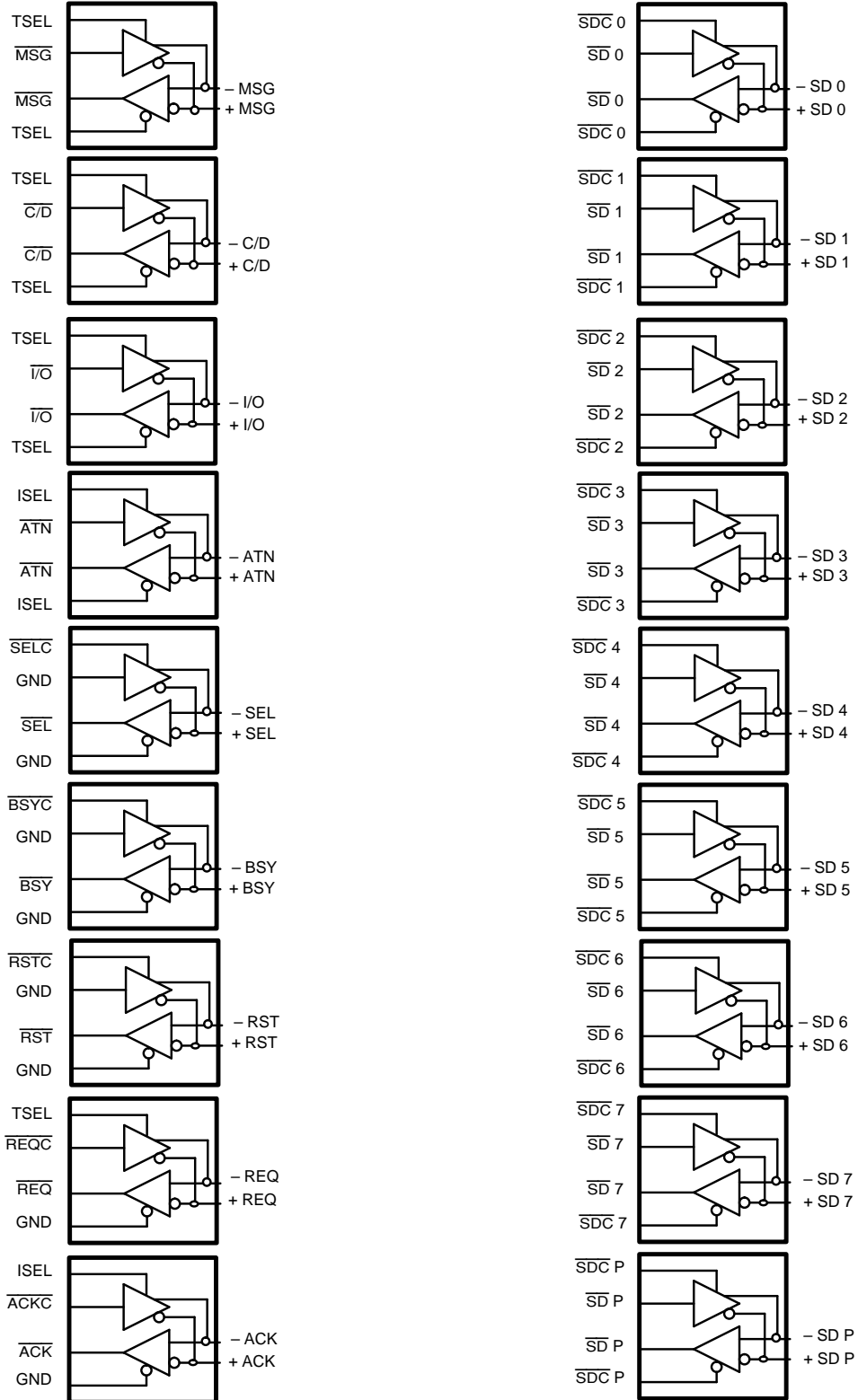

17348B-15

Differential Transceiver Connections for the Differential SCSI Bus Configuration Using 75176A Transceiver

PIN DESCRIPTION

Host Interface Signals

DMA 15–0

Data/DMA Bus

(Input/Output, Active High, Internal Pull-up)

The configuration of this bus depends on the Bus Mode 1–0 (BUSMD 1–0) inputs. When the device is configured for single bus operation, the host can access the internal register set on the lower eight lines while DMA accesses can be made to the FIFO using the entire bus. When using the Byte Mode via the BHE and A0 inputs the data can be transferred on either the upper or lower half of the DMA 15–0 bus.

DMAP 1–0

Data/DMA Parity Bus

(Input/Output, Active High, Internal Pull-up)

These lines are odd parity for the DMA 15–0 bus. DMAP 1 is the parity for the upper half of the bus (DMA 15–8) and DMAP 0 is the parity for the lower half of the bus (DMA 7–0).

ALE [A3]

Address Latch Enable [Address 3]

(Input, Active High)

This is a dual function input. When the device is configured for the dual bus mode (two buses, multiplexed and byte control), this input acts as ALE. As ALE, this input latches the address on the AD 7–0 bus on its low going edge. When the device is configured for all other bus modes, this input acts as A3. As A3, this input is the third bit of the address bus.

$\overline{\text{DMARD}}$ [A2]

DMA Read [Address 2]

(Input, Active Low [Active High])

This is a dual function input. When the device is configured for the dual bus mode (two buses, multiplexed and byte control), this input acts as $\overline{\text{DMARD}}$. As $\overline{\text{DMARD}}$, this input is the read signal for the DMA 15–0 bus. When the device is configured for all other bus modes, this input acts as A2. As A2, this input is the second bit of the address bus.

BHE [A1]

Bus High Enable [Address 1]

(Input, Active High)

This is a dual function input. When the device is configured for the dual bus mode (two buses, multiplexed and byte control), this input acts as BHE. As BHE, this input works in conjunction with AS0 to indicate the lines on which data transfer will take place. When the device is configured for all other bus modes this input acts as A1. As A1, this input is the first bit of the address bus.

AS0 [A0]

Address Status [Address 0]

(Input, Active High)

This is a dual function input. When the device is configured for the dual bus mode (two buses, multiplexed and byte control), this input acts as AS0. As AS0, this input works in conjunction with BHE to indicate the lines on which data transfer will take place. When the device is configured for all other bus modes, this input acts as A0. As A0, this input is the zeroth bit of the address bus.

The following is the decoding for the BHE and AS0 inputs:

BHE	AS0	Bus Used
1	1	Upper Bus – DMA 15–8, DMAP 1
1	0	Full Bus – DMA 15–0, DMAP 1–0
0	1	Reserved
0	0	Lower Bus – DMA 7–0, DMAP 0

DREQ

DMA Request

(Output, Active High, Hi-Z)

This output signal to the DMA controller will be active during DMA read and write cycles. During a DMA read cycle it will be active as long as there is a word (or a byte in the byte mode) in the FIFO to be transferred to memory. During a DMA write cycle it will be active as long as there is an empty space for a word (or a byte in mode 2) in the FIFO.

$\overline{\text{DACK}}$

DMA Acknowledge

(Input, Active Low)

This input signal from the DMA controller will be active during DMA read and write cycles. The $\overline{\text{DACK}}$ signal is used to access the DMA FIFO only and should never be active simultaneously with the $\overline{\text{CS}}$ signal, which accesses the registers only.

AD 7–0

Host Address Data Bus

(Input/Output, Active High, Internal Pull-up)

This bus is used only in the dual bus mode. This bus allows the host processor to access the device's internal registers while the DMA bus is transferring data. When using multiplexed bus, these lines can be used for address and data. When using non multiplexed bus these lines can be used for the data only.

$\overline{\text{DMAWR}}$

**DMA Write
(Input, Active Low)**

This signal writes the data onto the DMA 15–0 and DMAP 1–0 bus into the internal FIFO when $\overline{\text{DACK}}$ is also active. When in the single bus mode this signal must be tied to the $\overline{\text{WR}}$ signal.

$\overline{\text{RD}}$

**Read
(Input Active Low)**

This signal reads the internal device registers and places their contents on the data bus, when either $\overline{\text{CS}}$ signal or $\overline{\text{DACK}}$ signal is active.

$\overline{\text{WR}}$

**Write
(Input Active Low)**

This signal writes the internal device registers with the value present on the (AD 7–0 bus or the DMA 15–0 and DMAP 1–0 bus), when the $\overline{\text{CS}}$ signal is also active.

$\overline{\text{CS}}$

**Chip Select
(Input Active Low)**

This signal enables the read and write of the device registers. $\overline{\text{CS}}$ enables access to any register (including the FIFO) while the $\overline{\text{DACK}}$ enables access only to the FIFO. $\overline{\text{CS}}$ and $\overline{\text{DACK}}$ should never be active simultaneously in the single bus mode, they may however be active simultaneously in the dual bus mode provided the $\overline{\text{CS}}$ signal is not enabling access to the FIFO.

$\overline{\text{INT}}$

**Interrupt
(Output, Active Low, Open Drain)**

This signal is a non-maskable interrupt flag to the host processor. This signal is latched on the output on the high going edge of the clock. This flag may be cleared by reading the Interrupt Status Register (ISTAT) or by performing a device reset (hard or soft). This flag is not cleared by a SCSI reset.

$\overline{\text{DFMODE}}$

**Differential Mode
(Input, Active Low)**

This input is available only on the Am53CF96. This input configures the SCSI bus to either single ended or differential mode. When this input is active, the device operates in the differential SCSI mode. The SCSI data is available on the $\overline{\text{SD}}$ 7–0 lines and the high active transceiver enables on the $\overline{\text{SDC}}$ 7–0 outputs. When this input is inactive, the device operates in the single ended SCSI mode. The SCSI input data is available on $\overline{\text{SD}}$ 7–0 lines and the output data is available on $\overline{\text{SDC}}$ 7–0 lines. In the single ended SCSI mode, the $\overline{\text{SD}}$ 7–0 and the $\overline{\text{SDC}}$ 7–0 buses can be tied together externally.

BUSMD 1–0

**Bus Mode
(Input, Active High)**

These inputs configure the device for single bus or dual bus operation and the DMA bus width.

BUSMD1	BUSMD0	Bus Configuration
1	1	Two buses: 8-bit Host Bus and 16-bit DMA Bus Register Address on A 3–0 and Data on AD Bus
1	0	Two buses: Multiplexed and byte control Register Address on AD 3–0 and Data on AD Bus
0	1	Single bus: 8-bit Host Bus and 16-bit DMA Bus Register Address on A 3–0 and Data on DMA Bus
0	0	Single bus: 8-bit Host Bus and 8-bit DMA Bus Register Address on A 3–0 and Data on DMA Bus

CLK

**Clock
(Input)**

Clock input used to generate all the internal device timings. The maximum frequency of this input is 40 MHz. and a minimum of 10 MHz to maintain the SCSI bus timings.

RESET

**Reset
(Input, Active High)**

This input when active resets the device. The RESET input must be active for at least two CLK periods after the voltage on the power inputs have reached V_{cc} minimum.

SCSI Interface Signals

$\overline{\text{SD}}$ 7–0

**SCSI Data
(Input/Output, Active Low, Schmitt Trigger)**

When the device is configured in the Single Ended SCSI Mode ($\overline{\text{DFMODE}}$ inactive) these pins are defined as inputs for the SCSI data bus. When the device is configured in the Differential SCSI Mode ($\overline{\text{DFMODE}}$ active) these pins are defined as bidirectional SCSI data bus.

\overline{SDP} **SCSI Data Parity
(Input/Output, Active Low, Schmitt Trigger)**

When the device is configured in the Single Ended SCSI Mode (\overline{DFMODE} inactive) this pin is defined as the input for the SCSI data parity. When the device is configured in the Differential SCSI Mode (\overline{DFMODE} active) this pin is defined as bidirectional SCSI data parity.

 $\overline{SDC7-0}$ **SCSI Data Control
(Output, Active Low, Open Drain)**

When the device is configured in the Single Ended SCSI Mode (\overline{DFMODE} inactive) these pins are defined as outputs for the SCSI data bus. When the device is configured in the Differential SCSI Mode (\overline{DFMODE} active) these pins are defined as direction controls for the external differential transceivers. In this mode, a signal high state corresponds to an output to the SCSI bus and a low state corresponds to an input from the SCSI bus.

 \overline{SDCP} **SCSI Data Control Parity
(Output, Active Low, Open Drain)**

When the device is configured in the Single Ended SCSI Mode (\overline{DFMODE} inactive) this pin is defined as an output for the SCSI data parity. When the device is configured in the Differential SCSI Mode (\overline{DFMODE} active) this pin is defined as the direction control for the external differential transceiver. In this mode, a signal high state corresponds to an output to the SCSI bus and a low state corresponds to an input from the SCSI bus.

 \overline{MSG} **Message
(Input/Output, Active Low, Schmitt Trigger)**

This is a bidirectional signal with 48 mA output driver. It is an output in the Target mode and a Schmitt trigger input in the Initiator mode.

 $\overline{C/D}$ **Command/Data
(Input/Output, Schmitt Trigger)**

This is a bidirectional signal with 48 mA output driver. It is an output in the Target mode and a Schmitt trigger input in the Initiator mode.

 $\overline{I/O}$ **Input/Output
(Input/Output, Schmitt Trigger)**

This is a bidirectional signal with 48 mA output driver. It is an output in the Target mode and a Schmitt trigger input in the Initiator mode.

 \overline{ATN} **Attention
(Input/Output, Active Low, Schmitt Trigger)**

This signal is a 48 mA output in the Initiator mode and a Schmitt trigger input in the Target mode. This signal will

be asserted when the Initiator detects a parity error or it can be asserted via certain Initiator commands.

 \overline{BSY} **Busy
(Input, Active Low, Schmitt Trigger)**

This is a SCSI input signal with a Schmitt trigger.

 \overline{SEL} **Select
(Input, Active Low, Schmitt Trigger)**

This is a SCSI input signal with a Schmitt trigger.

 \overline{RST} **Reset
(Input, Active Low, Schmitt Trigger)**

This is a SCSI input signal with a Schmitt trigger.

 \overline{REQ} **Request
(Input, Active Low, Schmitt Trigger)**

This is a SCSI input signal with a Schmitt trigger.

 \overline{ACK} **Acknowledge
(Input, Active Low, Schmitt Trigger)**

This is a SCSI input signal with a Schmitt trigger.

 \overline{BSYC} **Busy Control
(Output, Active Low, Open Drain)**

This is a SCSI output with 48 mA drive. When the device is configured in the Single Ended SCSI Mode (\overline{DFMODE} inactive) this pin is defined as a BSY output for the SCSI bus. When the device is configured in the Differential SCSI Mode (\overline{DFMODE} active) this pin is defined as the direction control for the external differential transceiver. In this mode, a signal high state corresponds to an output to the SCSI bus and a low state corresponds to an input from the SCSI bus.

 \overline{SELC} **Select Control
(Output, Active Low, Open Drain)**

This is a SCSI output with 48 mA drive. When the device is configured in the Single Ended SCSI Mode (\overline{DFMODE} inactive) this pin is defined as a \overline{SEL} output for the SCSI bus. When the device is configured in the Differential SCSI Mode (\overline{DFMODE} active) this pin is defined as the direction control for the external differential transceiver. In this mode, a signal high state corresponds to an output to the SCSI bus and a low state corresponds to an input from the SCSI bus.

RSTC

Reset Control (Output, Active Low, Open Drain)

This is a SCSI output with 48 mA drive. The Reset SCSI command will cause the device to drive $\overline{\text{RSTC}}$ active for 25 ms–40 ms, which will depend on the CLK frequency and the conversion factor. When the device is configured in the Single Ended SCSI Mode ($\overline{\text{DFMODE}}$ inactive) this pin is defined as a $\overline{\text{RST}}$ output for the SCSI bus. When the device is configured in the Differential SCSI Mode ($\overline{\text{DFMODE}}$ active) this pin is defined as the direction control for the external differential transceiver. In this mode, a signal high state corresponds to an output to the SCSI bus and a low state corresponds to an input from the SCSI bus.

REQC

Request Control (Output, Active Low, Open Drain)

This is a SCSI output with 48 mA drive. This signal is activated only in the Target mode.

ACKC

Acknowledge Control (Output, Active Low, Open Drain)

This is a SCSI output with 48 mA drive. This signal is activated only in the Initiator mode.

ISEL

Initiator Select (Output, Active High)

This signal is available on the Am53CF96 only. This signal is active whenever the device is in the Initiator mode. In the differential mode this signal is used to enable the Initiator signals $\overline{\text{ACKC}}$ and $\overline{\text{ATN}}$ and the device also drives these signals.

TSEL

Target Select (Output, Active High)

This signal is available on the Am53CF96 only. This signal is active whenever the device is in the Target mode. In the differential mode this signal is used to enable the Target signals $\overline{\text{REQC}}$, $\overline{\text{MSG}}$, $\overline{\text{C/D}}$ and $\overline{\text{I/O}}$ and the device also drives these signals.

FUNCTIONAL DESCRIPTION

Register Map

Address (Hex.)	Operation	Register	Address (Hex.)	Operation	Register
00	Read	Current Transfer Count Register Low	07	Read	Current FIFO/Internal State Register
00	Write	Start Transfer Count Register Low	07	Write	Synchronous Offset Register
01	Read	Current Transfer Count Register Middle	08	Read/Write	Control Register 1
01	Write	Start Transfer Count Register Middle	09	Write	Clock Factor Register
02	Read/Write	FIFO Register	0A	Write	Forced Test Mode Register
03	Read/Write	Command Register	0B	Read/Write	Control Register 2
04	Read	Status Register	0C	Read/Write	Control Register 3
04	Write	SCSI Destination ID Register	0D	Read/Write	Control Register 4
05	Read	Interrupt Status Register	0E	Read	Current Transfer Count Register High
05	Write	SCSI Timeout Register	0E	Write	Start Transfer Count Register High
06	Read	Internal State Register	0F	Write	Data Alignment Register
06	Write	Synchronous Transfer Period Register			

Note:

Not all registers in this device are both readable and writable. Some read only registers share the same address with write only registers. The registers can be accessed by asserting the $\overline{\text{CS}}$ signal and then asserting either $\overline{\text{RD}}$ or $\overline{\text{WR}}$ signal depending on the operation to be performed. Only the FIFO Register can be accessed by asserting either $\overline{\text{CS}}$ or $\overline{\text{DACK}}$ in conjunction with $\overline{\text{RD}}$ and $\overline{\text{WR}}$ signals or $\overline{\text{DMARD}}$ and $\overline{\text{DMAWR}}$ signals. The register address inputs are ignored when $\overline{\text{DACK}}$ is used but must be valid when $\overline{\text{CS}}$ is used.

Current Transfer Count Register (00H, 01H, 0EH) Read Only

Current Transfer Count Register Address: 00H, 01H, 0EH
CTCREG Type: Read

23	22	21	20	19	18	17	16
CRVL23	CRVL22	CRVL21	CRVL20	CRVL19	CRVL18	CRVL17	CRVL16
X	X	X	X	X	X	X	X

15	14	13	12	11	10	9	8
CRVL15	CRVL14	CRVL13	CRVL12	CRVL11	CRVL10	CRVL9	CRVL8
X	X	X	X	X	X	X	X

7	6	5	4	3	2	1	0
CRVL7	CRVL6	CRVL5	CRVL4	CRVL3	CRVL2	CRVL1	CRVL0
X	X	X	X	X	X	X	X

17348B-16

CTCREG – Bits 23:0 – CRVL 23:0 – Current Value 23:0

This is a three-byte register which decrements to keep track of the number of bytes transferred during a DMA transfer. Reading these registers returns the current value of the counter. The counter will decrement by one for every byte and by two for every word transferred. The transaction is complete when the count reaches zero, and bit 4 of the Status Register (04H) is set. Should the sequence terminate early, the sum of the values in the Current FIFO (07H) and the Current Transfer Count Register reflect the number of bytes remaining.

The least significant byte is located at address 00H, the middle byte is located at address 01H, and the most significant byte is located at address 0EH. **Register 0EH extends the total width of the register from 16 to 24 bits, and is only enabled when the Enable Features bit (bit 6) of Control Register Two is set to a value of '1'.**

These registers are automatically loaded with the values in the Start Transfer Count Register every time a DMA command is issued. However, following a chip or power on reset, up until the time register 0EH is loaded, the Am53CF94/96's part-unique ID can be obtained by reading register 0EH.

In the Target mode, this counter is decremented by the active edge of $\overline{\text{DACK}}$ during the Data-In phase and by $\overline{\text{REQC}}$ during the Data-Out phase.

In the Initiator mode, the counter is decremented by the active edge of $\overline{\text{DACK}}$ during the Synchronous Data-In phase or by $\overline{\text{ACKC}}$ during the Asynchronous Data-In phase and by $\overline{\text{DACK}}$ during the Data-Out phase.

Start Transfer Count Register (00H, 01H, 0EH) Write Only

Start Transfer Count Register Address: 00H-01H
STCREG Type: Write

23	22	21	20	19	18	17	16
STVL23	STVL22	STVL21	STVL20	STVL19	STVL18	STVL17	STVL16
X	X	X	X	X	X	X	X

15	14	13	12	11	10	9	8
STVL15	STVL14	STVL13	STVL12	STVL11	STVL10	STVL9	STVL8
X	X	X	X	X	X	X	X

7	6	5	4	3	2	1	0
STVL7	STVL6	STVL5	STVL4	STVL3	STVL2	STVL1	STVL0
X	X	X	X	X	X	X	X

17348B-17

STCREG – Bits 15:0 – STVL 15:0 – Start Value 15:0

This is a three-byte register which contains the number of bytes to be transferred during a DMA operation. The value in the Start Transfer Count Register must be programmed prior to command execution.

The least significant byte is located at address 00H, the middle byte is located at address 01H, and the most significant byte is located at address 0EH. Register 0EH extends the total width of the register from 16 to 24 bits, and is only enabled when the Enable Features bit (bit 6) of Control Register Two is set to a value of '1'. This sets the maximum transfer count to 16.78 MBytes. When a value of '0' is written to these registers, the transfer count will be set to the maximum. A DMA NOP command must be issued before the transfer counter values can be written to 00H, 01H, and 0EH.

These registers retain their value until overwritten, and are therefore unaffected by a hardware or software reset. This reduces programming redundancy since it is no longer necessary to reprogram the count for subsequent DMA transfers of the same size.

FIFO Register (02H) Read/Write

FIFO Register Address: 02H
FFREG Type: Read/Write

7	6	5	4	3	2	1	0
FF7	FF6	FF5	FF4	FF3	FF2	FF1	FF0
0	0	0	0	0	0	0	0

17348B-18

FFREG – Bits 7:0 – FF 7:0 – FIFO 7:0

The FIFO on the Am53CF94/96 is 16 bytes deep and is used to transfer SCSI data to and from the ESC. The bottom of the FIFO may be accessed via a read or write to this register. This is the only register that can also be accessed by DACK along with DMARD or DMAWR or with REQ or ACK. This register is reset to zero by hardware or software reset, or at the start of a selection or reselection sequence, or if Clear FIFO command is issued.

Command Register (03H) Read/Write

Command Register Address: 03H
CMDREG Type: Read/Write

7	6	5	4	3	2	1	0
DMA	CMD6	CMD5	CMD4	CMD3	CMD2	CMD1	CMD0
x	x	x	x	x	x	x	x

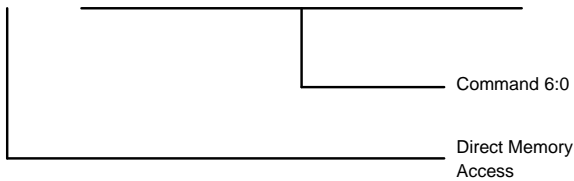

17348B-19

Commands to the ESC are issued by writing to this register which is two bytes deep. Commands may be queued, and will be read from the bottom of the queue. At the completion of the bottom command, the top command, if present, will drop to the bottom of the register to begin execution. All commands are executed within six clock cycles of dropping to the bottom of the Command Register, with the exception of the Reset SCSI Bus, Reset Device, and DMA Stop commands. These commands are not queued and are executed within four clock cycles of being loaded into the top this register.

Interrupts are sometimes generated upon command completion. Should both commands generate interrupts, and the first interrupt has not been serviced, the interrupt from the second (top) command will be stacked behind the first. The Status Register, Interrupt Register, and Internal State Register will be updated to apply to the second interrupt after the microprocessor services the first interrupt.

Reading this register will return the command currently being executed (or the last command executed if there are no pending commands). When this register is cleared, existing commands will be terminated and any queued commands will be ignored. However, it does not reset the register bits to '00H'.

CMDREG – Bit 7 – DMA – Direct Memory Access

When set, this bit notifies the device that the command is a DMA instruction, when reset it is a non-DMA instruction. For DMA instructions the Current Transfer Count Register (CTCREG) will be loaded with the contents of the Start Transfer Count Register (STCREG). The data is then transferred and the CTCREG is decremented for each byte until it reaches zero.

CMDREG – Bits 6:0 – CMD 6:0 – Command 6:0

These command bits decode the commands that the device needs to perform. There are a total of 31 commands grouped into four categories. The groups are Initiator Commands, Target Commands, Selection/Reselection Commands and General Purpose Commands.

Initiator Commands

CMD6	CMD5	CMD4	CMD3	CMD2	CMD1	CMD0	Command
0	0	1	0	0	0	0	Information Transfer
0	0	1	0	0	0	1	Initiator Command Complete Steps
0	0	1	0	0	1	0	Message Accepted
0	0	1	1	0	0	0	Transfer Pad Bytes
0	0	1	1	0	1	0	*Set $\overline{\text{ATN}}$
0	0	1	1	0	1	1	*Reset $\overline{\text{ATN}}$

Target Commands

CMD6	CMD5	CMD4	CMD3	CMD2	CMD1	CMD0	Command
0	1	0	0	0	0	0	Send Message
0	1	0	0	0	0	1	Send Status
0	1	0	0	0	1	0	Send Data
0	1	0	0	0	1	1	Disconnect Steps
0	1	0	0	1	0	0	Terminate Steps
0	1	0	0	1	0	1	Target Command Complete Steps
0	1	0	0	1	1	1	*Disconnect
0	1	0	1	0	0	0	Receive Message Steps
0	1	0	1	0	0	1	Receive Command
0	1	0	1	0	1	0	Receive Data
0	1	0	1	0	1	1	Receive Command Steps
0	0	0	0	1	0	0	*DMA Stop
0	0	0	0	1	0	1	Access FIFO Command

Idle Commands

CMD6	CMD5	CMD4	CMD3	CMD2	CMD1	CMD0	Command
1	0	0	0	0	0	0	Reselect Steps
1	0	0	0	0	0	1	Select without $\overline{\text{ATN}}$ Steps
1	0	0	0	0	1	0	Select with $\overline{\text{ATN}}$ Steps
1	0	0	0	0	1	1	Select with $\overline{\text{ATN}}$ and Stop Steps
1	0	0	0	1	0	0	*Enable Selection/Reselection
1	0	0	0	1	0	1	Disable Selection/Reselection
1	0	0	0	1	1	0	Select with $\overline{\text{ATN3}}$ Steps
1	0	0	0	1	1	1	Reselect with $\overline{\text{ATN3}}$ Steps

General Commands

CMD6	CMD5	CMD4	CMD3	CMD2	CMD1	CMD0	Command
0	0	0	0	0	0	0	*No Operation
0	0	0	0	0	0	1	*Clear FIFO
0	0	0	0	0	1	0	*Reset Device
0	0	0	0	0	1	1	Reset SCSI Bus

Note:

*Denotes commands which do not generate interrupts upon completion.

Status Register (04H) Read

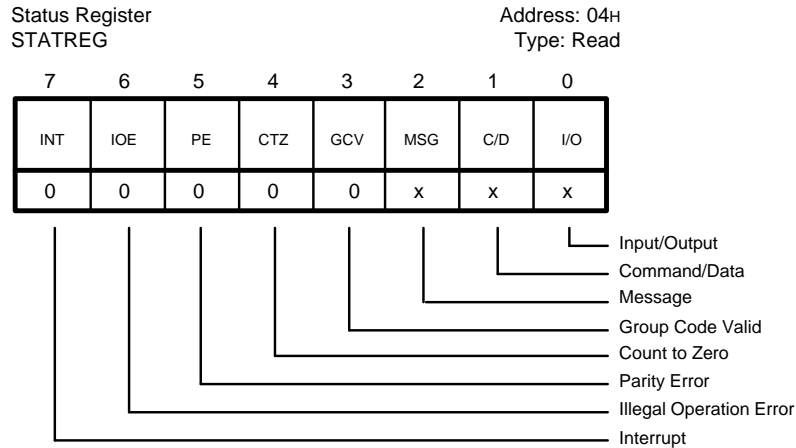

17348B-20

This read only register contains flags to indicate the status and phase of the SCSI transactions. It indicates whether an interrupt or error condition exists. It should be read every time the host is interrupted to determine which device is asserting an interrupt. If the ENF bit is set (CNTLREG2, bit 6), the SCSI bus phase of the last complete command (preceding the interrupt) will be latched until the Interrupt Status Register (INSTREG) is read. If the ENF bit is disabled, this register will reflect the current bus phase. If command stacking is used, two interrupts might occur. Reading this register will clear the status information for the first interrupt and update the Status Register for the second interrupt.

STATREG – Bit 7 – INT – Interrupt

The INT bit is set when the device asserts the interrupt output. This bit will be cleared by a hardware or software reset. Reading the Interrupt Status Register (INSTREG) will deassert the interrupt output and also clear this bit.

STATREG – Bit 6 – IOE – Illegal Operation Error

The IOE bit is set when an illegal operation is attempted. This condition will not cause an interrupt, it will be detected by reading the Status Register (STATREG) while servicing another interrupt. The following conditions will cause the IOE bit to be set:

- DMA and SCSI transfer directions are opposite.
- FIFO overflows or data is overwritten.
- In Initiator mode an unexpected phase change detected during synchronous data transfer.
- Command Register overwritten.

This bit will be cleared by reading the Interrupt Status Register (INSTREG) or by a hard or soft reset.

STATREG – Bit 5 – PE – Parity Error

The PE bit is set if any of the parity checking options are enabled and the device detects a parity error on bytes sent or received on the SCSI Bus. Parity options are controlled by bits 5:4 in Control Register One (CNTLREG1), and by bits 2:0 in Control Register Two

(CNTLREG2). The combination of enabled options will determine if parity is generated from the data bytes internally by the chip, or if it is passed between buffer and SCSI Bus without being altered. Detection of a parity error condition will not cause an interrupt but will be reported with other interrupt causing conditions.

This bit will be cleared by reading the Interrupt Status Register (INSTREG) or by a hard or soft reset.

STATREG – Bit 4 – CTZ – Count To Zero

The CTZ bit is set when the Current Transfer Count Register (CTCREG) has counted down to zero. This bit will be reset when the CTCREG is written with a non-zero value.

Reading the Interrupt Status Register (INSTREG) will not affect this bit. This bit will however be cleared by a hard or soft reset.

Note:

A non-DMA NOP will not reset the CTZ bit since it does not load the CTCREG. However, a DMA NOP will reset this bit since it loads the CTCREG.

STATREG – Bit 3 – GCV – Group Code Valid

The GCV bit is set if the group code field in the Command Descriptor Block (CDB) is one that is defined by the ANSI Committee in their document X3.131 – 1986. If the SCSI-2 Feature Enable (S2FE) bit in the Control Register 2 (CNTLREG2) is set, Group 2 commands will be treated as ten byte commands and the GCV bit will be set. If S2FE is reset then Group 2 commands will be treated as reserved commands. Group 3 and 4 commands will always be considered reserved commands. The device will treat all reserved commands as six byte commands. Group 6 commands will always be treated as vendor unique six byte commands and Group 7 commands will always be treated as vendor unique ten byte commands.

The GCV bit is cleared by reading the Interrupt Status Register (INSTREG) or by a hard or soft reset.

STATREG – Bit 2 – MSG – Message

STATREG – Bit 1 – C/D – Command/Data

STATREG – Bit 0 – I/O – Input/Output

Bit2 MSG	Bit1 C/D	Bit0 I/O	SCSI Phase
1	1	1	Message In
1	1	0	Message Out
1	0	1	Reserved
1	0	0	Reserved
0	1	1	Status
0	1	0	Command
0	0	1	Data_In
0	0	0	Data_Out

The MSG, C/D and I/O bits together can be referred to as the SCSI Phase bits. They indicate the phase of the SCSI bus. These bits may be latched or unlatched depending on whether or not the ENF bit in Control Register Two is set.

In the latched mode the SCSI phase bits are latched at the end of a command and the latch is opened when the Interrupt Status Register (INSTREG) is read. In the unlatched mode, they indicate the phase of the SCSI bus when this register is read.

SCSI Destination ID Register (04H) Write

SCSI Destination ID Register
SDIDREG

Address: 04H
Type: Write

7	6	5	4	3	2	1	0
RES	RES	RES	RES	RES	DID2	DID1	DID0
0	0	0	0	0	x	x	x

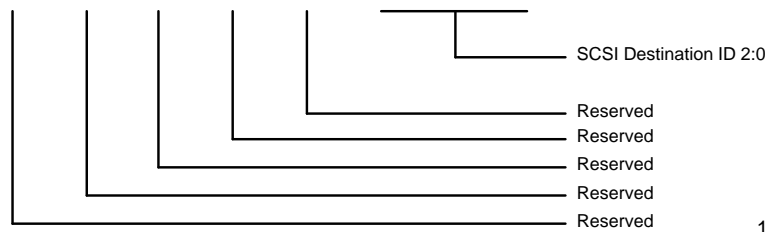

17348B-21

SDIDREG – Bits 7:3 – RES – Reserved

SDIDREG – Bits 2:0 – DID 2:0 – Destination ID 2:0

The DID 2:0 bits are the encoded SCSI ID of the device on the SCSI bus which needs to be selected or reselected.

At power-up the state of these bits is undefined. The DID 2:0 bits are not affected by reset.

DID2	DID1	DID0	SCSI ID
1	1	1	7
1	1	0	6
1	0	1	5
1	0	0	4
0	1	1	3
0	1	0	2
0	0	1	1
0	0	0	0

Interrupt Status Register (05H) Read

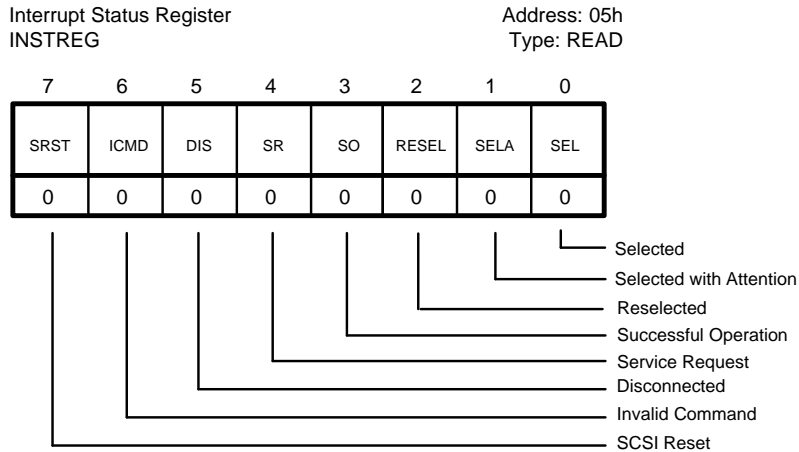

17348B-22

The Interrupt Status Register (INSTREG) will indicate the reason for the interrupt. This register is used with the Status Register (STATREG) and Internal State Register (ISREG) to determine the reason for the interrupt. Reading the INSTREG will clear all three registers. Therefore the Status Register (STATREG) and Internal State Register (ISREG) should be examined prior to reading the INSTREG.

INSTREG – Bit 7 – SRST – SCSI Reset

The SRST bit will be set if a SCSI Reset is detected and SCSI reset reporting is enabled via the DISR (bit 6) of Control Register One (CNTLREG1).

INSTREG – Bit 6 – ICMD – Invalid Command

The ICMD bit will be set if the device detects an illegal command code. This bit is also set if a command code is detected from a mode that is different from the mode the device is currently in. Once this bit is set, and invalid command interrupt will be generated.

INSTREG – Bit 5 – DIS – Disconnected

The DIS bit can be set in the Target or the Initiator mode when the device disconnects from the SCSI bus. In the Target mode this bit will be set if a Terminate or a Command Complete steps causes the device to disconnect from the SCSI bus. In the Initiator mode this bit will be set if the Target disconnects; while in Idle mode, this bit will be set if a selection or reselection timeout occurs.

INSTREG – Bit 4 – SR – Service Request

The SR bit can be set in the Target or the Initiator mode when another device on the SCSI bus has a service

request. In the Target mode this bit will be set when the Initiator asserts the \overline{ATN} signal. In the Initiator mode this bit is set when a Command Steps Successfully Completed Command is issued.

INSTREG – Bit 3 – SO – Successful Operation

The SO bit can be set in the Target or the Initiator mode when an operation has successfully completed. In the Target mode this bit will be set when any Target or Idle state command is completed. In the Initiator mode this bit is set after a Target has been successfully selected, after a command has successfully completed and after an information transfer command when the Target requests a Message In phase.

INSTREG – Bit 2 – RESEL – Reselected

The RESEL bit is set at the end of the reselection phase indicating that the device has been reselected as an Initiator.

INSTREG – Bit 1 – SELA – Selected with Attention

The SELA bit is set at the end of the selection phase indicating that the device has been selected as a Target by the Initiator and that the \overline{ATN} signal was active during the selection.

INSTREG – Bit 0 – SEL – Selected

The SEL bit is set at the end of the selection phase indicating that the device has been selected as a Target by the Initiator and that the \overline{ATN} signal was inactive during the selection.

SCSI Timeout Register (05H) Write

SCSI Timeout Register
STIMREG
Address: 05H
Type: Write

7	6	5	4	3	2	1	0
STIM7	STIM6	STIM5	STIM4	STIM3	STIM2	STIM1	STIM0
X	X	X	X	X	X	X	X

17348B-23

This register determines how long the Initiator (Target) will wait for a response to a Selection (Reselection) before timing out. It should be set to yield 250 ms to comply with ANSI standards for SCSI, but the maximum time out period may be calculated using the following formulas.

Note: A hardware reset will clear this register.

STIMREG – Bits 7:0 – STIM 7:0 – SCSI Timer 7:0

The value loaded in STIM 7:0 can be calculated as shown below:

STIM 7:0 =

$$[(\text{SCSI Time Out}) (\text{Clock Frequency}) / (8192 (\text{Clock Factor}))]$$

Example:

SCSI Time Out (in seconds): 250 ms. (Recommended by the ANSI Standard) = 250 x 10⁻³ s.

Clock Frequency: 20 MHz. (assume) = 20 x 10⁶ Hz.

Clock Factor: CLKF 2:0 from Clock Conversion Register (09H) = 5

$$\text{STIM 7:0} = (250 \times 10^{-3}) \times (20 \times 10^6) / (8192 (5)) = 122 \text{ decimal}$$

Internal State Register (06H) Read

Internal State Register
ISREG
Address: 06H
Type: Read

7	6	5	4	3	2	1	0
RES	RES	RES	RES	$\overline{\text{SOF}}$	IS2	IS1	IS0
X	X	X	X	0	0	0	0

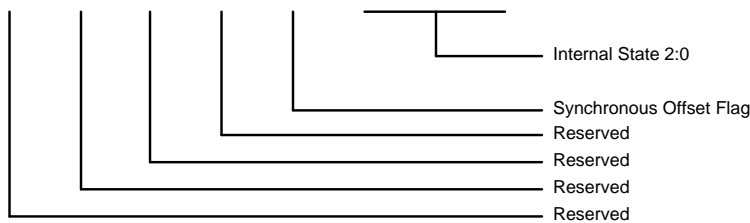

17348B-24

The Internal State Register (ISREG) tracks the progress of a sequence-type command. It is updated after each successful completion of an intermediate operation. If an error occurs, the host can read this register to determine the point where the command failed and take the necessary procedure for recovery. Reading the Interrupt Status Register (INSTREG) while an interrupt is pending will clear this register. A hard or soft reset will also zero this register .

ISREG – Bits 7:4 – RES – Reserved

ISREG – Bit 3 – $\overline{\text{SOF}}$ – Synchronous Offset Flag

The SOF is reset when the Synchronous Offset Register (SOFREG) has reached its maximum value.

Note:

The SOF bit is active Low.

ISREG – Bits 2:0 – IS 2:0 – Internal State 2:0

The IS 2:0 bits along with the Interrupt Status Register (INSTREG) indicates the status of the successfully completed intermediate operation. Refer to the Status Decode section for more details.

Initiator Select without $\overline{\text{ATN}}$ Steps		
Internal State Register (06H) Bits 2:0 (Hex)	Interrupt Status Register (05H) Bits 7:0 (Hex)	Explanation
0	20	Arbitration steps completed. Selection time-out occurred, then disconnected
4	18	Selection without $\overline{\text{ATN}}$ steps fully executed
3	18	Sequence halted during command transfer due to premature phase change (Target)
2	18	Arbitration and selection completed; sequence halted because Target failed to assert command phase

Initiator Select with $\overline{\text{ATN}}$ Steps		
Internal State Register (06H) Bits 2:0 (Hex)	Interrupt Status Register (05H) Bits 7:0 (Hex)	Explanation
0	20	Arbitration steps completed. Selection time-out occurred then disconnected
4	18	Selection with $\overline{\text{ATN}}$ steps fully executed
3	18	Sequence halted during command transfer due to premature phase change; some CDB bytes may not have been sent; check FIFO flags
2	18	Message out completed; sent one message byte with $\overline{\text{ATN}}$ true, then released $\overline{\text{ATN}}$; sequence halted because Target failed to assert command phase after message byte was sent
0	18	Arbitration and selection completed; sequence halted because Target did not assert message out phase; $\overline{\text{ATN}}$ still driven by ESC

Initiator Select with $\overline{\text{ATN3}}$ Steps		
Internal State Register (06H) Bits 2:0 (Hex)	Interrupt Status Register (05H) Bits 7:0 (Hex)	Explanation
0	20	Arbitration steps completed. Selection time-out occurred then disconnected
4	18	Selection with $\overline{\text{ATN3}}$ steps fully executed
3	18	Sequence halted during command transfer due to premature phase change; some CDB bytes may not have been sent; check FIFO flags
2	18	One, two, or three message bytes sent; sequence halted because Target failed to assert command phase after third message byte, or prematurely released message out phase; $\overline{\text{ATN}}$ released only if third message byte was sent
0	18	Arbitration and selection completed; sequence halted because Target failed to assert message out phase; $\overline{\text{ATN}}$ still driven by ESC

Initiator Select with $\overline{\text{ATN}}$ and Stop Steps		
Internal State Register (06H) Bits 2:0 (Hex)	Interrupt Status Register (05H) Bits 7:0 (Hex)	Explanation
0	20	Arbitration steps completed. Selection time-out occurred then disconnected
0	18	Arbitration and selection completed; sequence halted because Target failed to assert message out phase; $\overline{\text{ATN}}$ still asserted by ESC
1	18	Message out completed; one message byte sent; $\overline{\text{ATN}}$ on

Target Select without \overline{ATN} Steps

Internal State Register (06H) Bits 2:0 (Hex)	Interrupt Status Register (05H) Bits 7:0 (Hex)	Explanation
2	11	Selected; received entire CDB; check group code valid bit
1	11	Sequence halted in command phase due to parity error; some CDB bytes may not have been received; check FIFO flags; Initiator asserted \overline{ATN} in command phase
2	01	Selected; received entire CDB; check group code valid bit
1	01	Sequence halted in command phase because of parity error; some CDB bytes may not have been received; check FIFO flags
0	01	Selected; loaded bus ID into FIFO; null-byte message loaded into FIFO

Target Select with \overline{ATN} Steps, SCSI-2 Bit NOT SET

Internal State Register (06H) Bits 2:0 (Hex)	Interrupt Status Register (05H) Bits 7:0 (Hex)	Explanation
2	12	Selection complete; received one message byte and entire CDB; Initiator asserted \overline{ATN} during command phase
1	12	Halted in command phase; parity error and \overline{ATN} true
0	12	Selected with \overline{ATN} ; stored bus ID and one message byte; sequence halted because \overline{ATN} remained true after first message byte
2	02	Selection completed; received one message byte and the entire CDB
1	02	Sequence halted in command phase because of parity error; some CDB bytes not received; check group code valid bit and FIFO flags
0	02	Selected with \overline{ATN} ; stored bus ID and one message byte; sequence halted because of parity error or invalid ID message

Target Select with \overline{ATN} Steps, SCSI-2 Bit SET

Internal State Register (06H) Bits 2:0 (Hex)	Interrupt Status Register (05H) Bits 7:0 (Hex)	Explanation
6	12	Selection completed; received three message bytes and entire CDB. \overline{ATN} is true
5	12	Halted in command phase; parity error and \overline{ATN} true
4	12	\overline{ATN} remained true after third message byte
2	12	Selection completed; Initiator deasserts \overline{ATN} after receipt of one message byte; entire CDB received. \overline{ATN} asserted during command phase
1	12	Sequence halted during command phase because of parity error; one message byte received; some bytes of CDB not received; parity error and \overline{ATN} true
0	12	Selected with \overline{ATN} ; stored bus ID and one message byte; sequence halted because of parity error or invalid ID message; \overline{ATN} is true
6	02	Selection completed; received three message bytes and the entire CDB
5	02	Received three message bytes then halted in command phase because of parity error; some CDB bytes not received; check group code valid bit and FIFO flags
4	02	Parity error during second or third message byte
2	02	Selection completed; Initiator deasserts \overline{ATN} after receipt of one message byte; entire CDB received
1	02	Sequence halted during command phase because of parity error; one message byte received; some bytes of CDB not received; check FIFO flags and group code valid bit
0	02	Selected with \overline{ATN} ; stored bus ID and one message byte; sequence halted because of parity error or invalid ID message

Target Receive Command Steps		
Internal State Register (06H) Bits 2:0 (Hex)	Interrupt Status Register (05H) Bits 7:0 (Hex)	Explanation
2	18	Received entire CDB; Initiator asserted \overline{ATN}
1	18	Sequence halted during command transfer due to parity error; \overline{ATN} asserted by Initiator
2	08	Received entire CDB
1	08	Sequence halted during command transfer due to parity error; check FIFO flags

Target Disconnect Steps		
Internal State Register (06H) Bits 2:0 (Hex)	Interrupt Status Register (05H) Bits 7:0 (Hex)	Explanation
2	28	Disconnect steps fully executed; disconnected; bus is free
1	18	Two message bytes sent; sequence halted because Initiator asserted \overline{ATN}
0	18	One message byte sent; sequence halted because Initiator asserted \overline{ATN}

Target Terminate Steps		
Internal State Register (06H) Bits 2:0 (Hex)	Interrupt Status Register (05H) Bits 7:0 (Hex)	Explanation
2	28	Terminate steps fully executed; disconnected; bus is free
1	18	Status and message bytes sent; sequence halted because Initiator asserted \overline{ATN}
0	18	Status byte sent; sequence halted because Initiator asserted \overline{ATN}

Synchronous Transfer Period Register (06H) Write

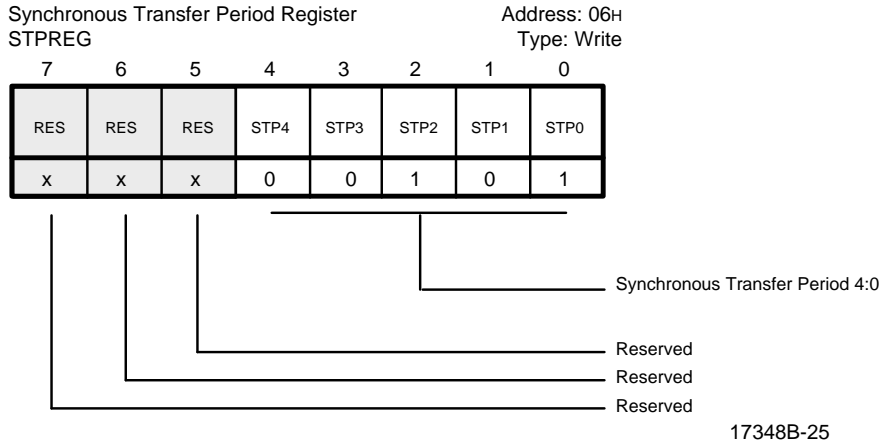

The Synchronous Transfer Period Register (STPREG) contains a 5-bit value indicating the number of clock cycles each byte will take to be transferred over the SCSI bus in synchronous mode. The minimum value allowed is 4. The STPREG defaults to 5 clocks/byte after a hard or soft reset.

STPREG – Bits 7:5 – RES – Reserved

STPREG – Bits 4:0 – STP 4:0 – Synchronous Transfer Period 4:0

The STP 4:0 bits are programmed to specify the synchronous transfer period or the number of clock cycles for each byte transfer in the synchronous mode. The minimum value for STP 4:0 is 4 clocks/byte. Missing table entries follow the binary code.

STP4	STP3	STP2	STP1	STP0	Clocks/Byte
0	0	1	0	0	4
0	0	1	0	1	5
0	0	1	1	0	6
0	0	1	1	1	7
•	•	•	•	•	•
•	•	•	•	•	•
1	1	1	1	1	31
0	0	0	0	0	32
0	0	0	0	1	33
0	0	0	1	0	34
0	0	0	1	1	35

Current FIFO/Internal State Register (07H) Read

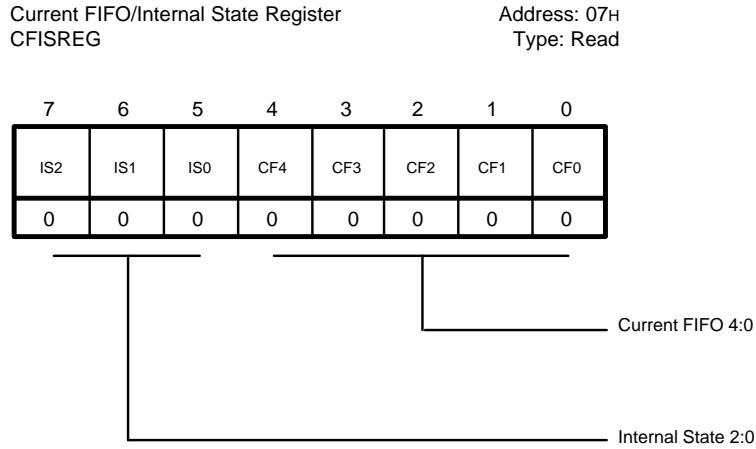

17348B-26

This register has two fields, the Current FIFO field and the Internal State field.

CFISREG – Bits 7:5 – IS 2:0 – Internal State 2:0

The Internal State Register (ISREG) tracks the progress of a sequence-type command.

The IS 2:0 bits are duplicated from the IS 2:0 field in the Internal State Register (ISREG) in the normal mode. If the device is in the test mode, (see CNTLREG1, bit 3) IS 0 is set to indicate that the offset value is non-zero. A non-zero value indicates that synchronous data

transfer can continue. A zero value indicates that the synchronous offset count has been reached and no more data can be transferred until an acknowledge is received.

CFISREG – Bits 4:0 – CF 4:0 – Current FIFO 4:0

The CF 4:0 bits are the binary coded value of the number of bytes in the FIFO. These bits should not be read when the device is transferring data since this count may not be stable.

Synchronous Offset Register (07H) Write

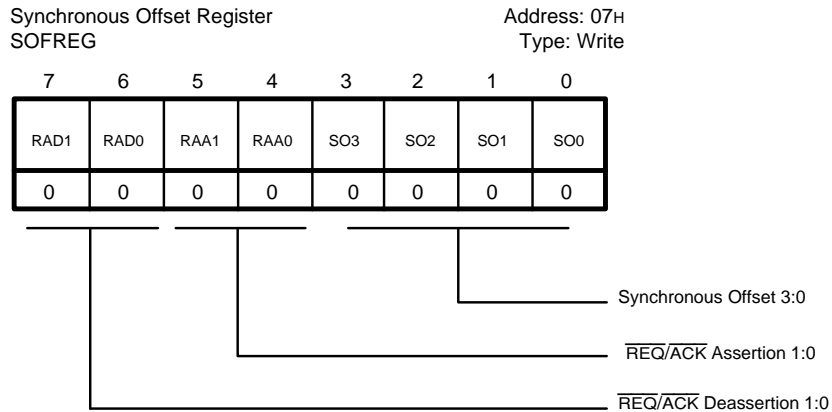

17348B-27

The Synchronous Offset Register (SOFREG) controls $\overline{REQ}/\overline{ACK}$ deassertion/assertion delay and stores a 4-bit count of the number of bytes that can be sent to (or received from) the SCSI bus during synchronous transfers without an \overline{ACK} (or \overline{REQ}). Bytes exceeding the threshold will be sent one byte at a time (asynchronously). That is, each byte will require an $\overline{ACK}/\overline{REQ}$ handshake. To set up an asynchronous transfer, the SOFREG is set to zero. The SOFREG is set to zero after a hard or soft reset.

SOFREG – Bits 7:6 – RAD 1:0

These bits may be programmed to control the deassertion delay of the \overline{REQ} and \overline{ACK} signals during synchronous transfers. Deassertion delay is expressed as input clock cycles, and depends on the implementation of FASTCLK. (See CNTLREG3, bit 3)

SOFREG Bits 7:6	FASTCLK Ctrl 3, Bit 3	Deassertion Delay REQ/ACK Input CLK Cycles
00	0	Default – 0 cycles
01	0	1/2 cycle early
10	0	1 cycle delay
11	0	1/2 cycle delay
00	1	Default – 0 cycles
01	1	1/2 cycle delay
10	1	1 cycle delay
11	1	1 1/2 cycles delay

SOFREG Bits 5:4	Assertion Delay REQ/ACK Input CLK Cycles
00	Default – 0 cycles
01	1/2 cycle delay
10	1 cycle delay
11	1 1/2 cycles delay

SOFREG – Bits 5:4 – RAA 1:0

These bits may be programmed to control the assertion delay of the \overline{REQ} and \overline{ACK} signals during synchronous transfers. Unlike deassertion delay, assertion delay is independent of the FASTCLK setting.

SOFREG – Bits 3:0 – SO 3:0 – Synchronous Offset 3:0

The SO 3:0 bits are the binary coded value of the number of bytes that can be sent to (or received from) the SCSI bus without an \overline{ACK} (or \overline{REQ}) signal. A zero value designates Asynchronous xfer, while a non-zero value designates the number of bytes for synchronous transfer.

Control Register One (08H) Read/Write

Control Register One
CNTLREG1

Address: 08H
Type: Read/Write

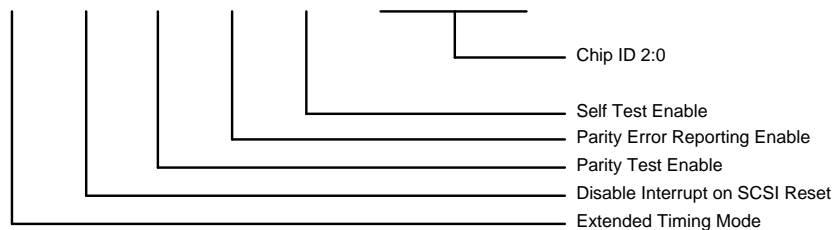
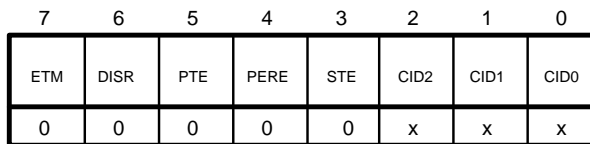

17348B-28

The Control Register 1 (CNTLREG1) sets up the device with various operating parameters.

CNTLREG1 – Bit 7 – ETM – Extended Timing Mode

Enabling this feature will increase the minimum setup time for data being transmitted on the SCSI bus. This bit should only be set if the external cabling conditions produce SCSI timing violations. FASTCLK operation is unaffected by this feature.

CNTLREG1 – Bit 6 – DISR – Disable Interrupt on SCSI Reset

The DISR bit masks the reporting of the SCSI reset. When the DISR bit is set and a SCSI reset is asserted, the device will disconnect from the SCSI bus and remain idle without interrupting the host processor. When the DISR bit is reset and a SCSI reset is asserted the device will respond by interrupting the host processor. The DISR bit is reset to zero by a hard or soft reset.

CNTLREG1 – Bit 5 – PTE – Parity Test Enable

The PTE bit is for test use only. When the PTE bit is set the parity on the output (SCSI or host processor) bus is forced to the value of the MSB (bit 7) of the output data from the internal FIFO. This allows parity errors to be created to test the hardware and software. The PTE bit is reset to zero by a hard or soft reset. This bit should not be set in normal operation.

CNTLREG1 – Bit 4 – PERE – Parity Error Reporting Enable

The PERE bit enables the checking and reporting of parity errors on incoming SCSI bytes during the information transfer phase. When the PERE bit set and bad parity is detected, the PE bit in the STATREG is will be set but an interrupt will not be generated. In the Initiator mode the \overline{ATN} signal will also be asserted on the SCSI bus. When

the PERE bit is reset and bad parity occurs it is not detected and no action is taken.

CNTLREG1 – Bit 3 – STE – Self Test Enable

The STE bit is for test use only. When the STE bit is set the device is placed in a test mode which enables the device to access the test register at address 0AH. To reset this bit and to resume normal operation the device must be issued a hard or soft reset.

CNTLREG1 – Bit 2:0 – CID 2:0 – Chip ID 2:0

The Chip ID 2:0 bits specify the binary coded value of the device ID on the SCSI bus. The device will arbitrate with this ID and will respond to Selection or Reselection to this ID. At power-up the state of these bit are undefined. These bits are not affected by hard or soft reset.

Clock Factor Register (09H) Write

Clock Factor Register
CLKFREG

Address: 09H
Type: Write

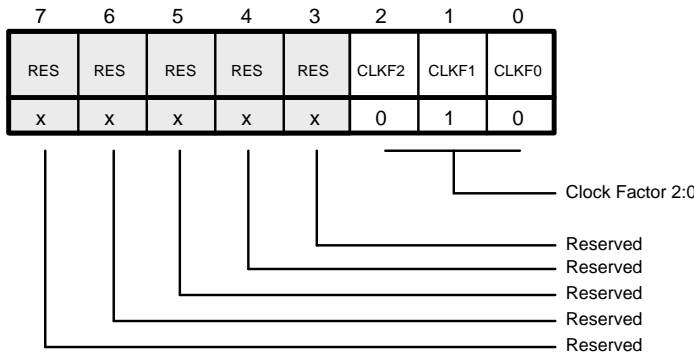

17348B-29

The Clock Factor Register (CLKFREG) must be set to indicate the input frequency range of the device. This value is crucial for controlling various timings to meet the SCSI specification. The value of bits CLKF 2:0 can be calculated by rounding off the quotient of (Input Clock Frequency in MHz)/(5 MHz). The device has a frequency range of 10 to 40 MHz.

CLKFREG – Bits 7:3 – RES – Reserved

CLKFREG – Bits 2:0 – CLKF 2:0 – Clock Factor 2:0

The CLKF 2:0 bits specify the binary coded value of the clock factor. The CLKF 2:0 bits will default to a value of 2 by a hard or soft reset.

CLKF2	CLKF1	CLKF0	Input Clock Frequency in MHz
0	1	0	10
0	1	1	10.01 to 15
1	0	0	15.01 to 20
1	0	1	20.01 to 25
1	1	0	25.01 to 30
1	1	1	30.01 to 35
0	0	0	35.01 to 40

Forced Test Mode Register (0AH) Write

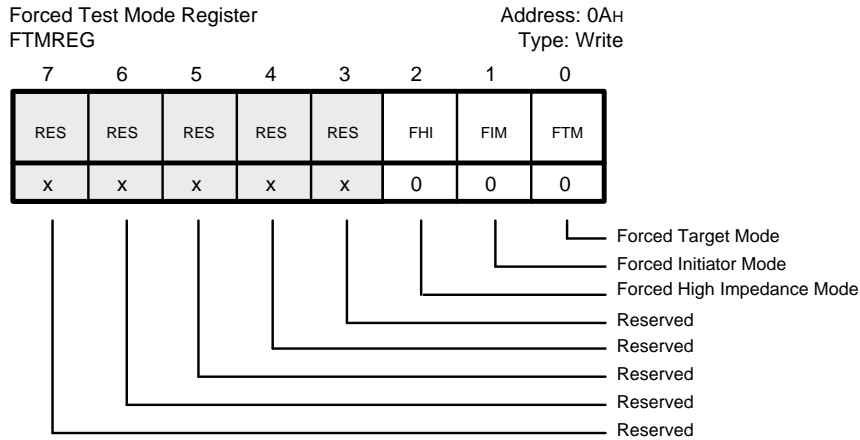

17348B-30

The Forced Test Mode Register (FTMREG) is for test use only. The STE bit in the Control Register One (CNTLREG1) must be set for the FTMREG to operate.

FTMREG – Bits 7:3 – RES – Reserved

FTMREG – Bit 2 – FHI – Forced High Impedance Mode

The FHI bit when set places all the output and bidirectional pins into a high impedance state. It is zeroed by a hardware or chip reset.

FTMREG – Bit 1 – FIM – Forced Initiator Mode

The FIM bit when set forces the ESC into the Initiator mode. As an Initiator, the device will drive SCSI data lines, and \overline{ACK} or \overline{ATN} (depending on the bus phase and

the command loaded in the Command Register). The ESC will remain in this mode for as long as \overline{BSY} is asserted, or until a Reset SCSI Bus or Reset Device command occurs. During normal operation this bit must not be set.

FTMREG – Bit 0 – FTM – Forced Target Mode

The FTM bit when set forces the ESC into the Target mode. As a Target, the device does not assert \overline{BSY} ; rather, it drives SCSI data lines, \overline{REQ} , \overline{MSG} , $\overline{C/D}$ or $\overline{I/O}$ (depending on the command loaded in the Command Register). The ESC will remain in this mode until a Disconnect Steps, Reset SCSI Bus, or Reset Device command occurs. During normal operation this bit must not be set.

Control Register Two (0BH) Read/Write

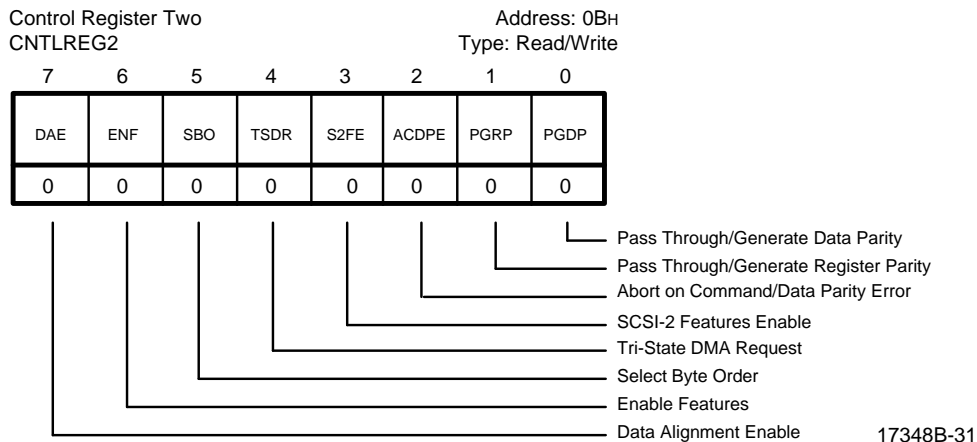

17348B-31

The Control Register Two (CNTLREG2) sets up the device with various operating parameters.

CNTLREG2 – Bit 7 – DAE – Data Alignment Enable

The DAE bit is used in the Initiator Synchronous Data-In phase only. When the DAE bit is set one byte is reserved at the bottom of the FIFO when the phase changes to the Synchronous Data-In phase. The contents of this byte will become the lower byte of the DMA word (16-bit)

transferred to the memory, the upper byte being the first byte of the first word received from the SCSI bus.

Note:

If an interrupt is received for a misaligned boundary on a phase change to synchronous data the following recovery procedure may be followed. The host processor should copy the byte at the start address in the host memory to the Data Alignment Register 0FH (DALREG)

and then issue an information transfer command. The first word the device will write to the memory (via DMA) will consist of the lower byte from the DALREG and the upper byte from the first byte received from the SCSI bus.

The DAE bit must be set before the phase changes to the Synchronous Data-In. The DAE bit is reset to zero by a hard or soft reset or by writing the DALREG when interrupted in the Synchronous Data-In phase.

CNTLREG2 – Bit 6 – ENF – Enable Features

A software or hardware reset will clear this bit to its default value of '0'; a SCSI reset will leave this bit unaffected. When set to a value of '1', this bit activates the following product enhancements:

- 1) The Current Transfer Count Register High (0EH) will be enabled, extending the transfer counter from 16 to 24 bits to allow for larger transfers.
- 2) Following a chip or power on reset, up until the point where the Current Transfer Count Register High (0EH) is loaded with a value, it is possible to read the part-unique ID from this register.
- 3) The SCSI phase will be latched at the completion of each command by bits 2:0 in the Status Register (STATREG). When this bit is '0', the Status Register (STATREG) will reflect real-time SCSI phases.
- 4) The enable signal for the differential drivers may be delayed to avoid bus contention on the SCSI differential lines when the direction for $\overline{I/O}$ is switching. When the SCSI bus changes direction from input to output, the output drivers are not asserted for two clock cycles to avoid bus contention. When the bus changes from output to input, SDC7:0 are given time to switch direction before the SCSI drivers are asserted.

CNTLREG2 – Bit 5 – SBO – Select Byte Order

The SBO bit is used only when the BUSMD 1:0 = 10 to enable or disable the byte control on the DMA interface. When SBO is set and the BUSMD 1:0 = 10, the byte control inputs BHE and AS0 control the byte positions. When SBO is reset the byte control inputs BHE and AS0 are ignored.

CNTLREG2 – Bit 4 – TSDR – Tri-State DMA Request

The TSDR bit when set sends the DREQ output signal to high impedance state and the device ignores all activity on the DMA request (DREQ) input. This is useful for wiring-OR several devices that share a common DMA request line. When the TSDR bit is reset the DREQ output is driven to TTL levels.

CNTLREG2 – Bit 3 – S2FE – SCSI-2 Features Enable

The S2FE bit allows the device to recognize two SCSI-2 features: the extended message feature and the Group 2 command recognition. (These features can also be controlled independently by bits 6:5 in CNTLREG3).

Extended Message Feature: When the S2FE bit is set and the device is selected with attention, the device will monitor the \overline{ATN} signal at the end of the first message byte. If the \overline{ATN} signal is active, the device will request two more message bytes before switching to the command phase. If the \overline{ATN} signal is inactive the device will switch to the Command phase. When the S2FE bit is reset as a Target the device will request a single message byte. As an Initiator, the device will abort the selection sequence if the Target does not switch to the Command phase after receiving a single message byte.

Group 2 Command Recognition: When the S2FE bit is set, the GCV (Group Code Valid) bit in the STATREG (04H) is set, allowing the Group 2 commands to be recognized as 10 byte commands. When the S2FE bit is reset, the GCV bit in the STATREG is not set, and the device will interpret the Group 2 commands as reserved commands and will request 6 byte commands.

CNTLREG2 – Bit 2 – ACDPE – Abort on Command/Data Parity Error

The ACDPE bit when set allows the device to abort a command or data transfer when a parity error is detected. When the ACDPE bit is reset parity error is ignored.

CNTLREG2 – Bit 1 – PGRP – Pass Through/Generate Register Parity

The PGRP bit, when set, allows parity from DMAP1–0 to pass during register writes to the FIFO. Enabling this bit also causes parity checking as data is unloaded from the FIFO to the SCSI bus.

When this bit is reset to zero, parity is generated for register writes to the FIFO, however no additional checking will be done as FIFO data is unloaded to the SCSI bus unless the PGDP bit is set.

CNTLREG2 – Bit 0 – PGDP – Pass Through/Generate Data Parity

The PGDP bit, when set, allows parity from DMAP1–0 to pass during DMA writes to the FIFO. Parity checking will also be performed as data is unloaded from the FIFO to the SCSI bus.

When this bit is reset to zero, parity is generated during DMA Writes to the FIFO, however no additional checking will be done as FIFO data is unloaded, unless the PGRP bit is set.

Control Register Three (0CH) Read/Write

Control Register Three
CNTLREG3

Address: 0CH
Type: Read/Write

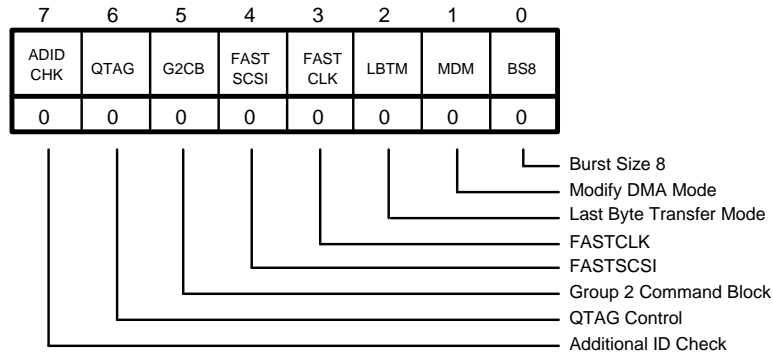

17348B-32

CNTLREG3 – Bit 7 – ADIDCHK – Additional ID Check

Enables additional check on ID message during bus-initiated Select or Reselect with \overline{ATN} . The ESC will check bits 7, and bits 5:3 in the first byte of the ID message during Selection of Reselection. An interrupt will be generated if bit 7 is '0', or if bits 5, 4, or 3 are '1'.

CNTLREG3 – Bit 6 – QTAG – QTAG Control

This bit controls the Queue Tag feature in the ESC. When enabled, the ESC is capable of receiving 3-byte messages during bus-initiated Select/Reselect with \overline{ATN} . (Bit 3, Control Register Two also enables this feature). The 3-byte message consists of one byte Identify Message and two bytes of Queue Tag message. The ESC will check the second byte for values of 20h, 21h, and 22h. If this condition is not satisfied, the sequence halts and the ESC generates an interrupt.

When the QTAG feature is not enabled, the ESC halts the Selected with \overline{ATN} sequence following the receipt of one ID message byte if \overline{ATN} is still true.

CNTLREG3 – Bit 5 – G2CB – Group 2 Command Block

When this bit is set, the ESC is capable of recognizing 10-byte Group 2 Commands as valid CDBs (Command Descriptor Blocks). (This feature is also controlled by bit 3 of CNTLREG2). When this feature is enabled, the Target receives 10 bytes of Group 2 commands, and sets the group code valid bit (bit 3) in Status Register (STATREG). When this feature is disabled, the Target receives only 6 bytes of command code, and does not set bit 3 in register (04H).

This bit may be programmed in conjunction with bit 6 (described above) to send 1 or 3 byte messages with 6 or 10 byte CDBs. The following table illustrates the transmission options:

CNTLREG3 – Bit 4 – FASTSCSI – Fast SCSI

CNTLREG3 – Bit 3 – FASTCLK – Fast SCSI Clocking

These bits configure the ESC's state machine to support both Fast SCSI timings and SCSI-1 timings. These bits will affect the SCSI transfer rate, and must be considered in conjunction with the ESC's clock frequency and mode of operation.

CNTLREG3 Bit 6 QTAG	CNTLREG3 Bit 5 G2CB	CNTLREG2 Bit 3 S2FE	Enabled Features
—	—	1	10-byte CDB, 3-byte message
1	0	0	3-byte message
0	1	0	10-byte CDB
1	1	0	10-byte CDB, 3-byte message
0	0	0	Features disabled

— = don't care

CNTLREG3 FASTSCSI Bit 4	CNTLREG3 FASTCLK Bit 3	Clock Frequency	Mode of Operation
1	1	25–40 MHz	10 MBytes/sec, Fast SCSI
0	1	25–40 MHz	5 MBytes/sec, SCSI-1
—	0	<= 25 MHz	5 MBytes/sec, SCSI-1

— = don't care

CNTLREG3 – Bit 2 – LBTM – Last Byte Transfer Mode

The LBTM bit specifies how the last byte in an odd byte transfer is handled during 16-bit DMA transfers (modes 1, 2, 3). This mode is not used if byte control is selected via BUSMD 1:0 = 10 and SBO (Select Byte Order) bit in the CNTLREG2 is set to '1'. This mode has no affect during 8-bit DMA transfers (mode 0) and on transfers on the SCSI bus.

When the LBTM bit is set the DREQ signal will not be asserted for the last byte, instead the host will read or write the last byte from or to the FIFO. When the LBTM bit is reset the DREQ signal will be asserted for the last byte and the following 16-bit DMA transfer will contain the last byte on the lower bus. While the upper bus (DMA 15:8/DMA 1) will be all ones.

The LBTM bit is reset by hard or soft reset.

CNTLREG3 – Bit 1 – MDM – Modify DMA Mode

The MDM bit is used to modify the timing of the \overline{DACK} signal with respect to the \overline{DMARD} and \overline{DMAWR} signals. The MDM bit is used in conjunction with the Burst Size 8 (BS8) bit in the CNTLREG3. Both bits have to be set for proper operation.

When the MDM bit is set and the device is in a DMA read or write mode the \overline{DACK} signal will remain asserted while the data is strobed by the \overline{DMARD} or \overline{DMAWR} signals. In the DMA read mode when BUSMD 1:0 = 11 the \overline{DACK} signal will toggle for every DMA read.

When the MDM bit is reset and the device is in a DMA read or write mode the \overline{DACK} signal will toggle every time the data is strobed by the \overline{DMARD} or \overline{DMAWR} signals.

CNTLREG3 – Bit 0 – BS8 – Burst Size 8

The BS8 bit is used to modify the timing of the DREQ signal with respect to the \overline{DMARD} and \overline{DMAWR} signals.

The BS8 bit is used in conjunction with the Modify DMA Mode (MDM) bit in the CNTLREG3. Both bits have to be set for proper operation.

When the BS8 bit is set the device delays the assertion of the DREQ signal until 8 bytes or 4 words transfer is possible.

When the BS8 bit is set and the device is in a DMA write mode the DREQ signal will be asserted only when 8 byte locations are available for writing. In the DMA read mode the DREQ signal will go active under the following circumstances:

At the end of a transfer,

- In the Target mode,
 - when the transfer is complete
 - or
 - when the \overline{ATN} signal is active
- In the Initiator mode,
 - when the Current Transfer Register (CTCREG) is decremented to zero
 - or
 - after any phase change

In the middle of a transfer

- In the Initiator mode,
 - when the last 8 bytes of the FIFO are full
 - during Synchronous Data-In transfer when the Event Transfer Count Register is greater than 7 and the last 8 bytes of the FIFO are full.

When the BS8 bit is reset and the device is in a DMA read or write mode the DREQ signal will toggle every time the data is strobed by the \overline{DMARD} or \overline{DMAWR} signals.

Using (Bit 0 (BS8) and Bit 1 (MDM) of Control Register Three (CNTLREG3), one can enable the different combination modes shown in the table below.

(MDM) Bit 1	(BS8) Bit 0	Function	Maximum Synchronous Offset
0	0	Normal DMA Mode	15
0	1	Burst Size 8 Mode	7
1	0	Reserved	–
1	1	Modified DMA Mode	7

Control Register Four (0DH)

Control Register Four
CNTLREG4

Address: 00H

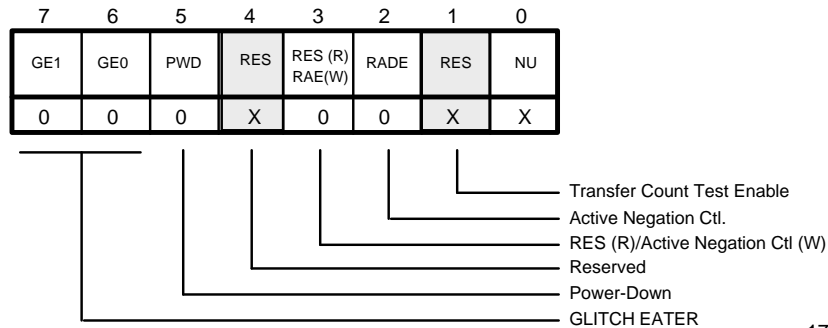

17348B-33

This register is used to control several AMD proprietary features implemented in the Am53CF94/96. At power up, this register will show a '0' value on all bits except bit 4.

CNTLREG4 – Bit 7:6 – GE1:0 – GLITCH EATER

The GLITCH EATER circuitry has been implemented on all SCSI input lines and are controlled by bits 7 and 6. The valid signal window may be adjusted by setting the bits in the combinations listed below.

CNTLREG4 Bit 7 GE1	CNTLREG4 Bit 6 GE0	Single-ended	Differential
0	0	12 ns	0 ns
1	0	25 ns	25 ns
0	1	35 ns	35 ns
1	1	0 ns	12 ns

CNTLREG4 – Bit 5 – PWD – Power-Down Feature

Setting this bit to '1' will enable AMD's exclusive power-down feature. This will turn off the input buffers on all the SCSI bus signal lines to reduce power consumption during the chip's sleep mode.

CNTLREG4 – Bit 4 – RES

This bit is reserved for internal use.

CNTLREG4 – Bit 3 (Read Only) – RES

This bit is reserved for internal use.

CNTLREG4 – Bit 3 (Write Only) – RAE – Active Negation Control

CNTLREG4 – Bit 2 – RADE – Active Negation Control

Bits 2 and 3 control the Active Negation Drivers which may be enabled on \overline{REQ} , \overline{ACK} , or DATA lines. The following table shows the programming options for this feature:

CNTLREG4 Bit 3 RAE	CNTLREG4 Bit 2 RADE	Function Selected
0	0	Active Negation Disabled
1	0	Active Negation on \overline{REQ} and \overline{ACK} only
—	1	Active Negation on \overline{REQ} , \overline{ACK} and DATA

— = don't care

CNTLREG4 – Bit 1 – RES

This bit is reserved for internal use.

CNTLREG4 – Bit 0 – NU – Not Used

The NCR53CF94/96 uses this bit to control back-to-back transfers. This bit may be read or written but is not used by the Am53CF94/96. Back-to-Back transfers are always enabled.

Data Alignment Register (0FH) Write

Data Alignment Register DALREG							Address: 0F H
							Type: Write
7	6	5	4	3	2	1	0
DA7	DA6	DA5	DA4	DA3	DA2	DA1	DA0
0	0	0	0	0	0	0	0

17348B-34

The Data Alignment Register (DALREG) is used if the first byte of a 16-bit DMA transfer from the SCSI bus to the host processor is misaligned. Prior to issuing an information transfer command, the host processor must set the Data Alignment Enable (DAE) bit in Control Register Two (CNTLREG2).

This register may be loaded immediately following the phase change to Synchronous Data In. This byte will become the LSB of the first word transmitted from the FIFO to the DMA controller. The MSB will be comprised of the first byte received over the SCSI bus. Together, these bytes constitute the first 16-bit word transferred to memory.

DALREG – Bits 7:0 – DA 7:0 – Data Alignment 7:0

Part-Unique ID Register (0EH) Read Only

This register extends the transfer counter from 16 to 24 bits and is only enabled when the ENF bit is set (bit 6, Control Register Two). The descriptions accompanying the Start Transfer Count Registers and the Current Count Registers should be referenced for more information regarding the transfer counter.

This register is also used to store the part-unique ID code for the Am53CF94/96. This information may be accessed when all of the following are true:

- 1) A value has not been loaded into this register
- 2) A DMA NOP command has been issued (code 80h)
- 3) Bit 6 in Control Register Two is set (ENF bit)
- 4) A power up or chip reset has taken place

When the above conditions are satisfied, the following bit descriptions apply:

	ID
Am53CF94, 3 V	12
Am53CF94, 5 V	12

COMMANDS

The device commands can be broadly divided into two categories, DMA commands and non-DMA commands. DMA commands are those which cause data movement between the host memory and the SCSI bus while non-

DMA commands are those that cause data movement between the device FIFO and the SCSI bus. The MSB of the command byte differentiate the DMA from the non-DMA commands.

Summary of Commands

Command	Command Code (Hex.)		Command	Command Code (Hex.)	
	Non-DMA Mode	DMA Mode		Non-DMA Mode	DMA Mode
Initiator Commands			Idle State Commands		
Information Transfer	10	90	Reselect Steps	40	C0
Initiator Command Complete Steps	11	91	Select without $\overline{\text{ATN}}$ Steps	41	C1
Message Accepted	12	–	Select with $\overline{\text{ATN}}$ Steps	42	C2
Transfer Pad Bytes	18	98	Select with $\overline{\text{ATN}}$ and Stop Steps	43	C3
Set $\overline{\text{ATN}}$	1A	–	Enable Selection/Reselection	44	C4
Reset $\overline{\text{ATN}}$	1B	–	Disable Selection/Reselection	45	C5
Target Commands			Select With $\overline{\text{ATN3}}$ Steps	46	C6
Send Message	20	A0	Reselect with $\overline{\text{ATN3}}$ Steps	47	C7
Send Status	21	A1	General Commands		
Send Data	22	A2	No Operation	00	80
Disconnect Steps	23	A3	Clear FIFO	01	81
Terminate Steps	24	A4	Reset Device	02	82
Target Command Complete Steps	25	A5	Reset SCSI bus	03	83
Disconnect	27	A7			
Receive Message	28	A8			
Receive Command Steps	29	A9			
Receive Data	2A	AA			
Receive Command Steps	2B	AB			
DMA Stop Command	04	84			
Access FIFO Command	05	85			

COMMAND DESCRIPTION

Initiator Commands

Initiator commands are executed by the device when it is in the Initiator mode. If the device is not in the Initiator mode and an Initiator command is received the device will ignore the command, generate an Invalid Command interrupt and clear the Command Register (CMDREG).

Should the Target disconnect from the SCSI bus by deasserting the BSY signal line while the ESC (Initiator) is waiting for the Target to assert REQ, a Disconnected Interrupt will be issued 1.5 to 3.5 clock cycles following BSY going false.

Upon receipt of the last byte during Msg In phase, ACK will remain asserted to prevent the Target from issuing any additional bytes, while the Initiator decides to accept/reject the message. If non-DMA commands are used, the last byte signals the FIFO is empty. If DMA commands are used, the transfer counter signals the last byte.

If parity checking is enabled in the Initiator mode and an error is detected, ATN will be asserted for the erroneous byte before deasserting ACK. An exception to this is following a phase change to Synchronous Data In.

To program Synchronous Transfer, the Synchronous Offset Register (SOFREG) must be set to a non-zero value. While in this mode, if the phase changes to Data In, the DMA interface is disabled, and parity generation is delayed. The Data In phase will latch the FIFO flags to indicate the number of bytes in the FIFO, clear the FIFO, load the FIFO with the first byte of Data In, generate an interrupt, and continue to load the FIFO with incoming bytes up to the synchronous offset.

Information Transfer Command (Command Code 10H/90H)

The Information Transfer command is used to transfer information bytes over the SCSI bus. This command may be issued during any SCSI Information Transfer phase. Synchronous data transmission requires use of the DMA mode.

The device will continue to transfer information until it is terminated by any one of the following conditions:

- The Target changes the SCSI bus phase before the expected number of bytes are transferred. The device clears the Command Register (CMDREG), and generates a service interrupt when the Target asserts REQ.
- Transfer is successfully complete. If the phase is Message Out, the device deasserts ATN before asserting ACK for the last byte of the message. When the Target asserts REQ, a service interrupt is generated.
- In the Message In phase when the device receives the last byte. The device keeps the ACK signal asserted and generates a Successful Operation interrupt.

During synchronous data Transfers the Target may send up to the maximum synchronous threshold number of REQ pulses to the Initiator. If it is the Synchronous Data-In phase then the Target sends the data and the REQ pulses. These bytes are stored by the Initiator in the FIFO as they are received.

Information Transfer Command, when issued during the following SCSI phases and terminated in synchronous data phases, is handled as described below:

- Message In/Status Phase – When a phase change to Synchronous Data-In or Synchronous Data-Out is detected by the device, the Command Register (CMDREG) is cleared and the DMA interface is disabled to disallow any transfer of data phase bytes. If the phase change is to Synchronous Data-In and bad parity is detected on the data bytes coming in, it is not reported since the Status Register (STATREG) will report the status of the command just completed. The parity error flag and the ATN signal will be asserted when the Transfer Information command begins execution.
- Message Out/Command Phase – When a phase change to Synchronous Data-In or Synchronous Data-Out is detected by the device, the Command Register (CMDREG) is cleared and the DMA interface is disabled to disallow any transfer of data phase bytes. If the phase change is to Synchronous Data-In and bad parity is detected on the data bytes coming in, it is not reported since the Status Register (STATREG) will report the status of the command just completed. The parity error flag and the ATN signal will be asserted when the Transfer Information command begins execution. The FIFO Register (FFREG) will be latched and will remain in that condition until the next command begins execution. The value in the FFREG indicates the number of bytes in the FIFO when the phase changed to Synchronous Data-In. These bytes are cleared from the FIFO, which now contains only the incoming data bytes.
- In the Synchronous Data-Out phase, the threshold counter is incremented as REQ pulses are received. The transfer is completed when the FIFO is empty and the Current Transfer Count Register (CTCREG) is zero. The threshold counter will not be zero.
- In the Synchronous Data-In phase, the Current Transfer Count Register (CTCREG) is decremented as bytes are read from the FIFO rather than being decremented when the bytes are being written to the FIFO. The transfer is completed when Current Transfer Count Register (CTCREG) is zero but the FIFO may not be empty.

Initiator Command Complete Steps (Command Code 11H/91H)

The Initiator Command Complete Steps command is normally issued when the SCSI bus is in the Status In phase. One Status byte followed by one Message byte is transferred if this command completes normally. After receiving the message byte the device will keep the $\overline{\text{ACK}}$ signal asserted to allow the Initiator to examine the message and assert the $\overline{\text{ATN}}$ signal if it is unacceptable. The command terminates early if the Target does not switch to the Message In phase or if the Target disconnects from the SCSI bus.

Message Accepted Command (Command Code 12H)

The Message Accepted Command is used to release the $\overline{\text{ACK}}$ signal. This command is normally used to complete a Message In handshake. Upon execution of this command the device generates a service request interrupt after $\overline{\text{REQ}}$ is asserted by the Target.

After the device has received the last byte of message, it keeps the $\overline{\text{ACK}}$ signal asserted. This allows the device to either accept or reject the message. To accept the message, Message Accepted Command is issued. To reject the message the $\overline{\text{ATN}}$ signal must be asserted (with the help of the Set $\overline{\text{ATN}}$ Command) before issuing the Message Accepted Command. In either case the Message Accepted Command has to be issued to release the $\overline{\text{ACK}}$ signal.

Transfer Pad Bytes Command (Command Code 18H/98H)

The Transfer Pad Bytes Command is used to recover from an error condition. This command is similar to the Information Transfer Command, only the information bytes consists of null data. It is used when the Target expects more data bytes than the Initiator has to send. It is also used when the Initiator receives more information than expected from the Target.

When sending data to the SCSI bus, the FIFO is loaded with null bytes which are sent out to the SCSI bus. Although an actual DMA request is not made, DMA must be enabled when pad bytes are transmitted since the ESC uses Current Transfer Count Register (CTCREG) to terminate transmission.

When receiving data from the SCSI bus, the device will receive the pad bytes and place them on the top of the FIFO and unload them from the bottom of the FIFO.

This command terminates under the same conditions as the Information Transfer Command, but the device does not keep the $\overline{\text{ACK}}$ signal asserted during the last byte of the Message In phase. Should this command terminate prematurely due to a disconnect or a phase change, (before the Current Transfer Count Register (CTCREG) decrements to zero), the FIFO may contain residual pad bytes.

Set $\overline{\text{ATN}}$ Command (Command Code 1AH)

The Set $\overline{\text{ATN}}$ Command is used to drive the $\overline{\text{ATN}}$ signal active on the SCSI bus. An interrupt is not generated at

the end of this command. The $\overline{\text{ATN}}$ signal is deasserted before asserting the $\overline{\text{ACK}}$ signal during the last byte of the Message Out phase.

Note:

The $\overline{\text{ATN}}$ signal is asserted by the device without this command in the following cases:

- If any select with $\overline{\text{ATN}}$ command is issued and the arbitration is won.
- An Initiator needs the Target's attention to send a message. The $\overline{\text{ATN}}$ signal is asserted before deasserting the $\overline{\text{ACK}}$ signal.

Reset $\overline{\text{ATN}}$ Command (Command Code 1BH)

The Reset $\overline{\text{ATN}}$ Command is used to deassert the $\overline{\text{ATN}}$ signal on the SCSI bus. An interrupt is not generated at the end of this command. This command is used only when interfacing with devices that do not support the Common Command Set (CCS). These older devices do not deassert their $\overline{\text{ATN}}$ signal automatically on the last byte of the Message Out phase. This device does deassert its $\overline{\text{ATN}}$ signal automatically on the last byte of the Message Out phase.

Target Commands

Target commands are executed by the device when it is in the Target mode. If the device is not in the Target mode and a Target command is received the device will ignore the command, generate an Invalid Command interrupt and clear the Command Register (CMDREG).

A SCSI bus reset during any Target command will cause the device to abort the command sequence, flag a SCSI bus reset interrupt (if the interrupt is enabled) and disconnect from the SCSI bus.

Normal or successful completion of a Target command will cause a Successful Operation interrupt to be flagged. If the $\overline{\text{ATN}}$ signal is asserted during a Target command sequence the Service Request bit is asserted in the Interrupt Status Register (INSTREG). If the $\overline{\text{ATN}}$ signal is asserted when the device is in an Idle state a Service Request interrupt will be generated, the Successful Operation bit in the Interrupt Status Register (INSTREG) will be reset and the Command Register (CMDREG) cleared.

Send Message Command (Command Code 20H/A0H)

The Send Message Command is used by the Target to inform the Initiator to receive a message. The SCSI bus phase lines are set to the Message In Phase and message bytes are transferred from the device FIFO to the buffer memory.

Send Status Command (Command Code 21H/A1H)

The Send Status Command is used by the Target to inform the Initiator to receive status information. The SCSI bus phase lines are set to the Status Phase and status bytes are transferred from the Target device to the Initiator device.

Send Data Command (Command Code 22H/A2H)

The Send Data Command is used by the Target to inform the Initiator to receive data bytes. The SCSI bus phase lines are set to the Data-In Phase and data bytes are transferred from the Target device to the Initiator device.

Disconnect Steps Command (Command Code 23H/A3H)

The Disconnect Steps Command is used by the Target to disconnect from the SCSI bus. This command is executed in two steps. In the Message In phase, the Target sends two bytes of the Save Data Pointers commands. Following transmission, the Target disconnects from the SCSI bus. Successful Operation and Disconnected bits are set in the Interrupt Status Register (INSTREG) upon command completion. If $\overline{\text{ATN}}$ signal is asserted by the Initiator then Successful Operation and Service Request bits are set in the INSTREG, the Command Register (CMDREG) is cleared and Disconnect Steps Command terminates without disconnecting.

Terminate Steps Command (Command Code 24H/A4H)

The Terminate Steps Command is used by the Target to disconnect from the SCSI bus. This command is executed in three steps. While in Status phase, the Target first sends a 1 byte status message. Following the Status phase the Target moves to the Message In phase and sends another 1 byte message. Lastly, the Target disconnects from the SCSI bus. The Disconnected bit is set in the Interrupt Status Register (INSTREG) upon command completion. If $\overline{\text{ATN}}$ signal is asserted by the Initiator, then Successful Operation and Service Request bits are set in the INSTREG, an interrupt is generated and the Command Register (CMDREG) is cleared and Terminate Steps Command terminates without disconnecting.

Target Command Complete Steps Command (Command Code 25H/A5H)

The Target Command Complete Steps Command is used by the Target to inform the Initiator of a linked command completion. This command consists of two steps. In the first step, the Target sends one status byte to the Initiator in the Status Phase. The Target then sends one message byte to the Initiator in the Message In Phase. The Successful Operation bit is set in the Interrupt Status Register (INSTREG) upon command completion. If $\overline{\text{ATN}}$ signal is asserted by the Initiator then Successful Operation and Service Request bits are set in the INSTREG, the Command Register (CMDREG) is cleared and Target Command Complete Steps Command terminates prematurely.

Disconnect Command (Command Code 27H/A7H)

The Disconnect Command is used by the Target to disconnect from the SCSI bus. All SCSI bus signals except $\overline{\text{RSTC}}$ are released and the device returns to the Disconnected state. The $\overline{\text{RSTC}}$ signal is driven active for about 25 micro seconds (depending on clock frequency

and clock factor). Interrupt is not generated to the micro-processor.

Receive Message Steps Command (Command Code 28H/A8H)

The Receive Message Steps Command is used by the Target to request message bytes from the Initiator. The Target receives the message bytes from the Initiator while the SCSI bus is in the Message Out Phase. The Successful Operation bit is set in the Interrupt Status Register (INSTREG) upon command completion. If $\overline{\text{ATN}}$ signal is asserted by the Initiator then Successful Operation and Service Request bits are set in the INSTREG, the Command Register (CMDREG) is cleared, but if a parity error is detected, the device ignores the received message bytes until $\overline{\text{ATN}}$ signal is deasserted, the Successful Operation bit is set in the INSTREG, and the CMDREG is cleared.

Receive Commands Command (Command Code 29H/A9H)

The Receive Commands Command is used by the Target to request command bytes from the Initiator. The Target receives the command bytes from the Initiator while the SCSI bus is in the Command Phase. The Successful Operation bit is set in the Interrupt Status Register (INSTREG) upon command completion. If $\overline{\text{ATN}}$ signal is asserted by the Initiator then Successful Operation and Service Request bits are set in the INSTREG, the Command Register (CMDREG) is cleared and the command terminates prematurely. If a parity error is detected, the device continues to receive command bytes until the transfer is complete. However, if the Abort on Command Data/Parity Error (ACDPE) bit in Control Register Two (CNTLREG2) is set, the command is terminated immediately. The Parity Error (PE) bit in the Status Register (STATREG) is set and CMDREG is cleared.

Receive Data Command (Command Code 2AH/AAH)

The Receive Data Command is used by the Target to request data bytes from the Initiator. During this command the Target receives the data bytes from the Initiator while the SCSI bus is in the Data-Out Phase. The Successful Operation bit is set in the Interrupt Status Register (INSTREG) upon command completion. If $\overline{\text{ATN}}$ signal is asserted by the Initiator then Successful Operation and Service Request bits are set in the INSTREG, the Command Register (CMDREG) is cleared and the command terminates prematurely. If a parity error is detected, the device continues to receive data bytes until the transfer is complete (Abort on Command/Data Parity Error (ACDPE) bit in Control Register Two (CNTLREG2) is reset). If the ACDPE bit is set, the command is terminated immediately. The Parity Error (PE) bit in the Status Register (STATREG) is set and CMDREG is cleared.

Receive Command Steps Command (Command Code 2BH/ABH)

The Receive Command Steps Command is used by the Target to request command information bytes from the Initiator. During this command the Target receives the command information bytes from the Initiator while the SCSI bus is in the Command Phase.

The Target device determines the command block length from the first byte. If an unknown length is received, the Start Transfer Count Register (STCREG) is loaded with five and the Group Code Valid (GCV) bit in the Status Register (STATREG) is reset. If a valid length is received, the STCREG is loaded with the appropriate value and the GCV bit in the STATREG is set. If \overline{ATN} signal is asserted by the Initiator then the Service Request bit is set in the Interrupt Status Register (INSTREG), and the Command Register (CMDREG) is cleared. If a parity error is detected, the command is terminated prematurely and the CMDREG is cleared.

DMA Stop Command (Command Code 04H/84H)

The DMA Stop Command is used by the Target to allow the microprocessor to discontinue data transfers due to a lack of activity on the DMA channel. This command is executed from the top of the command queue. If there is a queued command waiting execution, it will be overwritten and the Illegal Operation Error (IOE) bit in the Status Register (STATREG) will be set. This command is cleared from the command queue once it is decoded.

Caution must be exercised when using this command. The following conditions must be true:

- The DMA Stop Command can be used only during DMA Target Send Data Command or DMA Target Receive Data Command execution. In both cases the DMA controller and the ESC must be in the idle state.
- During a DMA Target Send Data Command: the FIFO is empty or the Current FIFO (CF 4:0) bits in the Current FIFO/Internal State Register (CFISREG) are zero.
- During a DMA Synchronous Target Receive Data Command: the Current Transfer Count Register (CTCREG) is zero, (indicated by the Count to Zero (CTZ) bit of the Status Register (STATREG)), or the Synchronous Offset Register (SOFREG) has reached its maximum value (indicated by the Synchronous Offset Flag (SOF) bit of the Internal State Register (ISREG)).
- During a DMA Asynchronous Target Receive Data Command: the FIFO is full (CF 4:0 set to '1' in the Current FIFO/Internal State Register (CFISREG)), or Current Transfer Count Register (CTCREG) is zero (indicated by the Count to Zero (CTZ) bit of the Status Register (STATREG)).

When conditions are satisfied, the ESC halts, asserts DREQ, and then waits for the DMA channel. If the ESC halted during Synchronous Transfer, the \overline{ACK} pulses not received from the SCSI bus remain outstanding.

Upon receipt of the DMA Stop Command, the ESC resets the DMA interface and DREQ pin, then terminates the command in progress. Ongoing SCSI sequences are completed as follows:

- Synch Data Send: completes when CTZ bit in Status Register is '1'.
- Synch Data Receive: when all outstanding \overline{ACK} s received, command completes
- Asynchronous Data Send: immediately completes
- Asynchronous Data Receive: immediately completes. Remaining data in FIFO should be removed by microprocessor.

Access FIFO Command (Command Code 05H/85H)

The host may issue the Access FIFO command following a Target Abort DMA or abort due to parity error. This command will give the DMA controller access to the data remaining in the FIFO. The following shall be true depending on the status of the DAE bit in CNTRLREG2:

DAE=1:

DREQ will be asserted if the FIFO has two or more bytes of data, and will deassert if the FIFO contains one or zero bytes of data.

DAE=0:

DREQ will be asserted if the FIFO is not empty, and will deassert when the FIFO is empty.

While DREQ is asserted, the DMA controller may read the data. This command is supported only in normal DMA mode.

Idle State Commands

The Idle State Commands can be issued to the device only when the device is disconnected from the SCSI bus. If these commands are issued to the device when it is logically connected to the SCSI bus, the commands are ignored, and the device will generate an Invalid Command interrupt and clear the Command Register (CMDREG).

Reselect Steps Command (Command Code 40H/C0H)

The Reselect Steps Command is used by the Target device to reselect an Initiator device. When this command is issued the device arbitrates for the control of the SCSI bus. If the device wins arbitration, it Reselects the Initiator device and transfers a single byte identify message. Before issuing this command the SCSI Timeout Register (STIMREG), the Control Register One (CNTLREG1) and the SCSI Destination ID Register (SDIDREG) must be set to the proper values. If DMA is enabled, the Start Transfer Count Register (STCREG) must be set to one. If DMA is not enabled, the single byte identify message must be loaded into the FIFO before issuing this command. This command will be terminated early if the SCSI Timeout Register times out, or if sequence terminates normally, a Successful Operation interrupt will be issued. This command also resets the Internal State Register (ISREG).

Select without $\overline{\text{ATN}}$ Steps Command (Command Code 41H/C1H)

The Select without $\overline{\text{ATN}}$ Steps Command is used by the Initiator to select a Target. When this command is issued the device arbitrates for the control of the SCSI bus. When the device wins arbitration, it selects the Target device and transfers the Command Descriptor Block (CDB). Before issuing this command the SCSI Timeout Register (STIMREG), the Control Register One (CNTLREG1) and the SCSI Destination ID Register (SDIDREG) must be set to the proper values. If DMA is enabled, the Start Transfer Count Register (STCREG) must be set to the total length of the command. If DMA is not enabled, the data must be loaded into the FIFO before issuing this command. This command will be terminated early if the SCSI Timeout Register times out or if the Target does not go to the Command Phase following the Selection Phase or if the Target exits the Command Phase prematurely. A Successful Operation interrupt will be generated following normal command execution.

Select with $\overline{\text{ATN}}$ Steps Command (Command Code 42H/C2H)

The Select with $\overline{\text{ATN}}$ Steps Command is used by the Initiator to select a Target. When this command is issued the device arbitrates for the control of the SCSI bus. When the device wins arbitration, it selects the Target device with the $\overline{\text{ATN}}$ signal asserted and transfers the Command Descriptor Block (CDB) and a one byte message. Before issuing this command the SCSI Timeout Register (STIMREG), the Control Register One (CNTLREG1) and the SCSI Destination ID Register (SDIDREG) must be set to the proper values. If DMA is enabled, the Start Transfer Count Register (STCREG) must be set to the total length of the command and message. If DMA is not enabled, the data must be loaded into the FIFO before issuing this command. This command will be terminated early in the following situations:

- The SCSI Timeout Register times out
- The Target does not go to the Message Out Phase following the Selection Phase
- The Target exits the Message Phase early
- The Target does not go to the Command Phase following the Message Out Phase
- The Target exits the Command Phase early

A Successful Operation/Service Request interrupt is generated when this command is completed successfully.

Select with $\overline{\text{ATN}}$ and Stop Steps Command (Command Code 43H/C3H)

The Select with $\overline{\text{ATN}}$ and Stop Steps Command is used by the Initiator to send messages with lengths other than 1 or 3 bytes. When this command is issued, the device executes the Selection process, transfers the first message byte, then STOPS the sequence. $\overline{\text{ATN}}$ is not deasserted at this time, allowing the Initiator to send additional message bytes after the ID message. To send these additional bytes, the Initiator must write the trans-

fer counter with the number of bytes which will follow, then issue an information transfer command. (Note: the Target is still in the message out phase when this command is issued). $\overline{\text{ATN}}$ will remain asserted until the transfer counter decrements to zero.

The SCSI Timeout Register (STIMREG), Control Register One (CNTLREG1), and the SCSI Destination ID Register (SDIDREG) must be set to the proper values before beginning the Initiator issues this command. This command will be terminated early if the STIMREG times out or if the Target does not go to the Message Out Phase following the Selection Phase.

Enable Selection/Reselection Command (Command Code 44H/C4H)

The Enable Selection/Reselection Command is used by the Target to respond to a bus-initiated Selection or Reselection. Upon disconnecting from the bus the Selection/Reselection circuit is automatically disabled by device. This circuit has to be enabled for the device to respond to subsequent reselection attempts and the Enable Selection/Reselection Command is issued to do that. This command is normally issued within 250 ms (select/reselect timeout) after the device disconnects from the bus. If DMA is enabled the device loads the received data to the buffer memory, but if the DMA is disabled, the received data stays in the FIFO.

Disable Selection/Reselection Command (Command Code 45H/C5H)

The Disable Selection/Reselection Command is used by the Target to disable response to a bus-initiated Reselection. When this command is issued before a bus initiated Selection or Reselection is initiated, it resets the internal mode bits previously set by the Enable Selection/Reselection Command. The device also generates a function complete interrupt to the processor. If however, this command is issued after a bus initiated Selection/Reselection has already begun the command is ignored since the Command Register (CMDREG) is held reset and all incoming commands are ignored. The device generates a selected or reselected interrupt when the sequence is complete.

Select with $\overline{\text{ATN3}}$ Steps Command (Command Code 46H/C6H)

The Select with $\overline{\text{ATN3}}$ Steps Command is used by the Initiator to select a Target. This command is similar to the Select with $\overline{\text{ATN}}$ Steps Command, except that it sends exactly three message bytes. When this command is issued the ESC arbitrates for the control of the SCSI bus. When the device wins arbitration, it selects the Target device with the $\overline{\text{ATN}}$ signal asserted and transfers the Command Descriptor Block (CDB) and three message bytes. Before issuing this command the SCSI Timeout Register (STIMREG), the Control Register One (CNTLREG1) and the SCSI Destination ID Register (SDIDREG) must be set to the proper values. If DMA is enabled, the Start Transfer Count Register (STCREG) must be set to the total length of the command. If DMA is not enabled, the data must be loaded

into the FIFO before issuing this command. This command will be terminated early in the following situations:

- The SCSI Timeout Register times out
- The Target does not go to the Message Out Phase following the Selection Phase
- The Target removes Command Phase early
- The Target does not go to the Command Phase following the Message Out Phase
- The Target exits the Command Out Phase early

A Successful Operation/Service Request interrupt is generated when this command is executed successfully.

Reselect with $\overline{\text{ATN3}}$ Steps Command (Command Code 47H/C7H)

The Queue Tag feature of the Select with $\overline{\text{ATN3}}$ command has been implemented in the Reselection command. Therefore, a Target reselecting an Initiator can use the QTAG feature of $\overline{\text{ATN3}}$. Following Reselection, one message byte and 2 bytes QTAG will be sent. The three message bytes must be loaded into the FIFO before this command is issued if DMA is not enabled.

General Commands

No Operation Command (Command Code 00H/80H)

The No Operation Command administers no operation, therefore an interrupt is not generated upon completion. This command is issued following the Reset Device Command to clear the Command Register (CMDREG).

A No Operation Command in the DMA mode may be used to verify the contents of the Start Transfer Count Register (STCREG). After the STCREG is loaded with the transfer count and a DMA No Operation Command is issued, reading the Current Transfer Count Register (CTCREG) will give the transfer count value.

Clear FIFO Command (Command Code 01H/81H)

The Clear FIFO Command is used to initialize the FIFO to the empty condition. The Current FIFO Register (CFISREG) reflects the empty FIFO status and the bottom of the FIFO is set to zero. No interrupt is generated at the end of this command.

Reset Device Command (Command Code 02H/82H)

The Reset Device Command immediately stops any device operation and resets all the functions of the device. It returns the device to the disconnected state and it also generates a hard reset. The Reset Device Command remains on the top of the Command Register FIFO holding the device in the reset state until the No Operation Command is loaded. The No Operation command serves to enable the Command Register.

Reset SCSI Bus Command (Command Code 03H/83H)

The Reset SCSI Bus Command forces the $\overline{\text{RSTC}}$ signal active for a period of 25 μs , and drives the chip to the Disconnected state. An interrupt is not generated upon command completion, however, if bit 6 is not disabled in Control Register One (CNTLREG1), a SCSI reset interrupt will be issued.

ABSOLUTE MAXIMUM RATINGS

Storage Temperature	-65°C to +150°C
Ambient Temperature		
Under Bias	-55°C to +125°C
V _{DD}	-0.5 V to +7.0 V
DC Voltage Applied		
to Any Pin	-0.5 to (V _{DD} + 0.5) V
Input Static Discharge Protection	...	4K V pin-to-pin (Human body model: 100 pF at 1.5K Ω)

Stresses above those listed under Absolute Maximum Ratings may cause permanent device failure. Functionality at or above these limits is not implied. Exposure to absolute maximum ratings for extended periods may affect device reliability.

OPERATING RANGES**Commercial Devices**

Ambient Temperature (T _A)	0°C to +70°C
Supply Voltage (V _{DD})	4.5 V to 5.5 V

Operating ranges define those limits between which the functionality of the device is guaranteed.

DC OPERATING CHARACTERISTICS

Parameter Symbol	Parameter Description	Pin Names	Test Conditions	Min	Max	Unit
I _{DD} S	Static Supply Current		V _{DD} MAX		4.0	mA
I _{DD} D	Dynamic Supply Current		V _{DD} MAX		30	mA
I _{LU}	Latch Up Current	All I/O	V _{LU} ≤ 10 V	-100	+100	mA
C	Capacitance	All Pins			10	pF
SCSI Pins						
V _{IH}	Input High Voltage	All SCSI Inputs		2.0	V _{DD} + 0.5	V
V _{IL}	Input Low Voltage	All SCSI Inputs		V _{SS} - 0.5	0.8	V
V _{IHST}	Input Hysteresis	All SCSI Inputs	4.5 V < V _{DD} < 5.5 V	300		mV
V _{OH}	Output High Voltage	\overline{SD} 7-0, \overline{SD} P	I _{OH} = -2 mA	2.4	V _{DD}	V
V _{SOL1}	SCSI Output Low Voltage	\overline{SD} 7-0, \overline{SD} P	I _{OL} = 4 mA	V _{SS}	0.4	V
V _{SOL2}	SCSI Output Low Voltage	\overline{SDC} 7-0, \overline{SDC} P, \overline{MSG} , $\overline{C/D}$, $\overline{I/O}$, \overline{ATN} , \overline{RSTC} , \overline{SELC} , \overline{BSYC} , \overline{ACKC} and \overline{REQC}	I _{OL} = 48 mA	V _{SS}	0.5	V
I _{IL}	Input Low Leakage		0.0 V < V _{IN} < 2.7 V	-10	+10	μA
I _{IH}	Input High Leakage		2.7 V < V _{IN} < V _{DD}	-10	+10	μA
I _{OZ}	High Impedance Leakage		0 V < V _{OUT} < V _{DD}	-10	+10	μA
Bidirectional Pins						
V _{IH}	Input High Voltage			2.0	V _{DD} + 0.5	V
V _{IL}	Input Low Voltage			V _{SS} - 0.5	0.8	V
V _{OH}	Output High Voltage	DMA 15-0 and DMAP 1-0 AD 7-0	I _{OH} = -2 mA I _{OH} = -1 mA	2.4	V _{DD}	V
V _{OL}	Output Low Voltage	DMA 15-0 and DMAP 1-0 AD 7-0	I _{OL} = 4 mA I _{OL} = 2 mA	V _{SS}	0.4	V
I _{IL}	Input Low Leakage	DMA 15-0, DMAP 1-0 and AD 7-0	0 V ≤ V _{IN} ≤ V _{IL}	-10	+10	μA
I _{IH}	Input High Leakage	DMA 15-0, DMAP 1-0 and AD 7-0	V _{IH} ≤ V _{IN} ≤ V _{DD}	-10	+10	μA
I _{OZ}	High Impedance Leakage		0 V < V _{OUT} < V _{DD}	-10	+10	μA
Output Pins						
V _{OH}	Output High Voltage	\overline{DREQ} , \overline{ISEL} , \overline{TSEL} , \overline{REQC}^* , \overline{ACKC}^*	I _{OH} = -2 mA	2.4	V _{DD}	V
V _{OL}	Output Low Voltage	\overline{DREQ} , \overline{ISEL} , \overline{TSEL} , \overline{REQC}^* , \overline{ACKC}^*	I _{OL} = 4 mA	V _{SS}	0.4	V
I _{OZ}	High Impedance Leakage		0 V < V _{OUT} < V _{DD}	-10	+10	μA

* \overline{REQC} and \overline{ACKC} in Differential Mode only.

DC OPERATING CHARACTERISTICS (continued)

Parameter Symbol	Parameter Description	Pin Names	Test Conditions	Min	Max	Unit
Input Pins						
V_{IH}	Input High Voltage	A 3-0, \overline{CS} , \overline{RD} , \overline{WR} , \overline{DMAWR} , CLK, BUSMD 1-0, \overline{DACK} , RESET, and \overline{DFMODE}		2.0	$V_{DD} + 0.5$	V
V_{IL}	Input Low Voltage	A 3-0, \overline{CS} , \overline{RD} , \overline{WR} , \overline{DMAWR} , CLK, BUSMD 1-0, \overline{DACK} , RESET, and \overline{DFMODE}		$V_{SS} + 0.5$	0.8	V
I_{IL}	Input Low Voltage	A 3-0, \overline{CS} , \overline{RD} , \overline{WR} , \overline{DMAWR} , CLK, BUSMD 1-0, \overline{DACK} , RESET, and \overline{DFMODE}	$0 \leq V_{IN} \leq V_{IL}$	-10	+10	μA
I_{IH}	Input High Voltage	A 3-0, \overline{CS} , \overline{RD} , \overline{WR} , \overline{DMAWR} , CLK, BUSMD 1-0, \overline{DACK} , RESET, and \overline{DFMODE}	$V_{IH} \leq V_{IN} \leq V_{DD}$	-10	+10	μA

SWITCHING TEST CIRCUIT

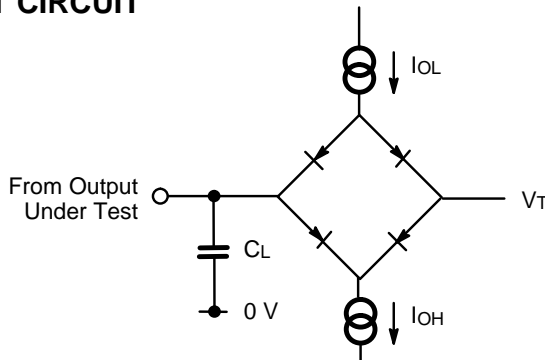



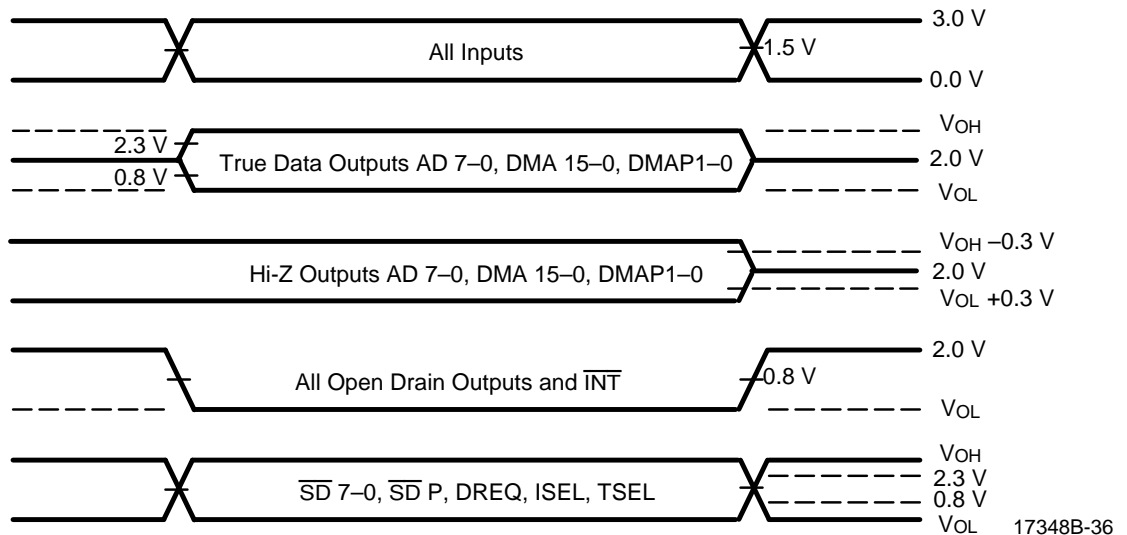

17348B-35

SWITCHING TEST WAVEFORMS

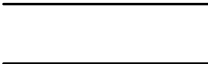

17348B-36

KEY TO SWITCHING WAVEFORMS

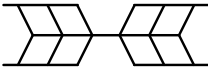
WAVEFORM	INPUTS	OUTPUTS
	Must be Steady	Will be Steady
	May Change from H to L	Will be Changing from H to L
	May Change from L to H	Will be Changing from L to H
	Don't Care, Any Change Permitted	Changing, State Unknown
	Does Not Apply	Center Line is High-Impedance "Off" State

KS000010

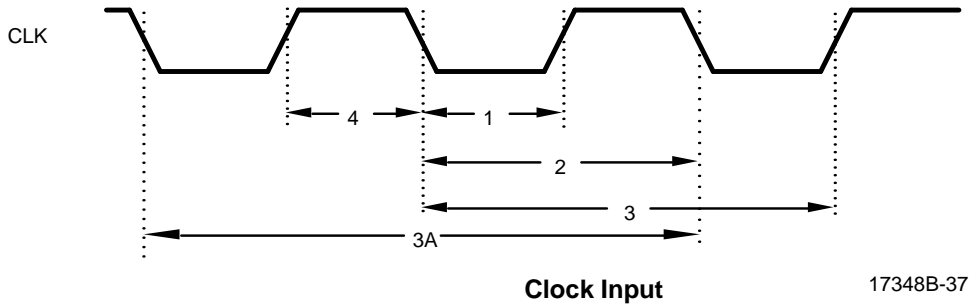

17348B-37

FastClk Disabled (Control Register Three (0CH) bit 3=0)

No.	Parameter Symbol	Parameter Description	Test Conditions	Min	Max	Unit
1	t_{PWL}^1	Clock Pulse Width Low		14.58	$0.65 \cdot t_{CP}$	ns
2	t_{CP}	Clock period ($1 \div$ Clock Frequency)		40	100	ns
3	t_L	Synchronization latency		54.58	$t_{PWL} + t_{CP}$	ns
4	t_{PWH}^1	Clock Pulse Width High		14.58	$0.65 \cdot t_{CP}$	ns

Note:

Clock Frequency Range for Fast Clk disabled.
 = 10 MHz to 25 MHz for Asynchronous transmission
 = 12 MHz to 25 MHz for Synchronous transmission

¹For Synchronous data transmissions, the following conditions must be true:

$2t_{CP} + t_{PWL} \geq 97.92 \text{ ns}$
 $2t_{CP} + t_{PWH} \geq 97.92 \text{ ns}$

FastClk Enabled (Control Register Three (0CH) bit 3=1)

No.	Parameter Symbol	Parameter Description	Test Conditions	Min	Max	Unit
1	t_{PWL}	Clock Pulse Width Low		$0.4 \cdot t_{CP}$	$0.6 \cdot t_{CP}$	ns
2	t_{CP}	Clock period ($1 \div$ Clock Frequency)		25	50	ns
3A	t_L	Synchronization latency		54.58	$2 \cdot t_{CP}$	ns
4	t_{PWH}	Clock Pulse Width High		$0.4 \cdot t_{CP}$	$0.6 \cdot t_{CP}$	ns

Note:

Clock Frequency Range for Fast Clk enabled.
 = 20 MHz to 40 MHz for Asynchronous Transmission
 = 20 MHz to 40 MHz for Synchronous Transmission

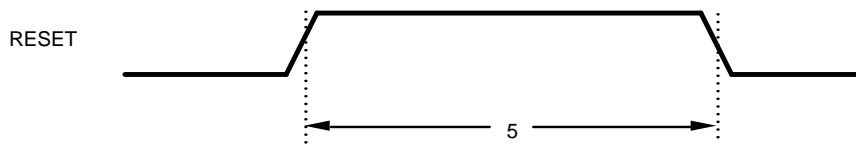

17348B-38

Reset Input

No.	Parameter Symbol	Parameter Description	Test Conditions	Min	Max	Unit
5	t_{PWH}	Reset Pulse Width High		500		ns

Note:

There is a one-to-one relationship between every AMD and Emulex Parameter (refer to Appendix B).

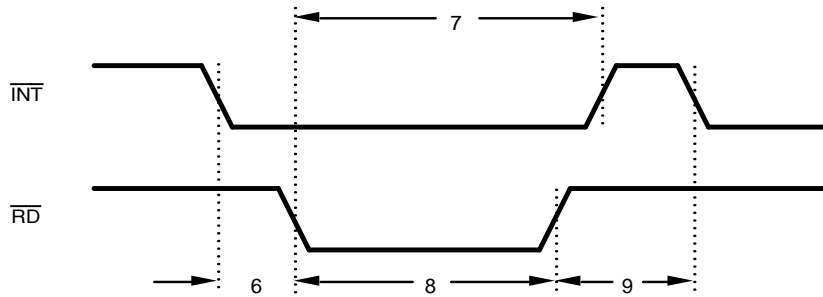

17348B-39

Interrupt Output

No.	Parameter Symbol	Parameter Description	Test Conditions	Min	Max	Unit
6	t_s	$\overline{INT} \downarrow$ to $\overline{RD} \downarrow$ Set Up Time		0		ns
7	t_{PD}	$\overline{RD} \downarrow$ to $\overline{INT} \uparrow$ Delay		0	100	ns
8	t_{PWL}	\overline{RD} Pulse Width Low		50		ns
9	t_{PD}	$\overline{RD} \uparrow$ to $\overline{INT} \downarrow$ Delay		t_L		ns

Note:

There is a one-to-one relationship between every AMD and Emulex Parameter (refer to Appendix B).

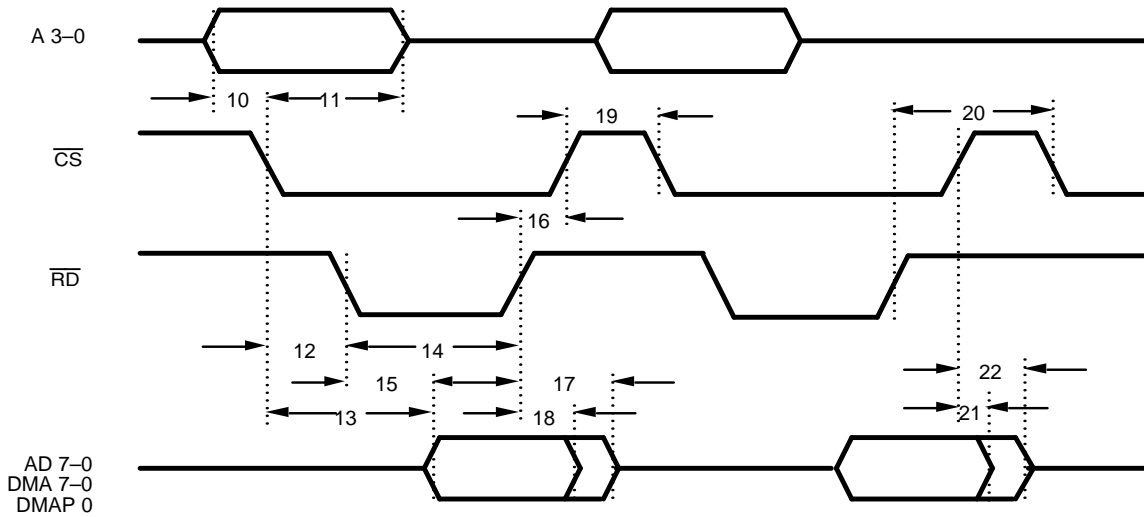

17348B-40

Register Read with Non-Multiplexed Address Data Bus

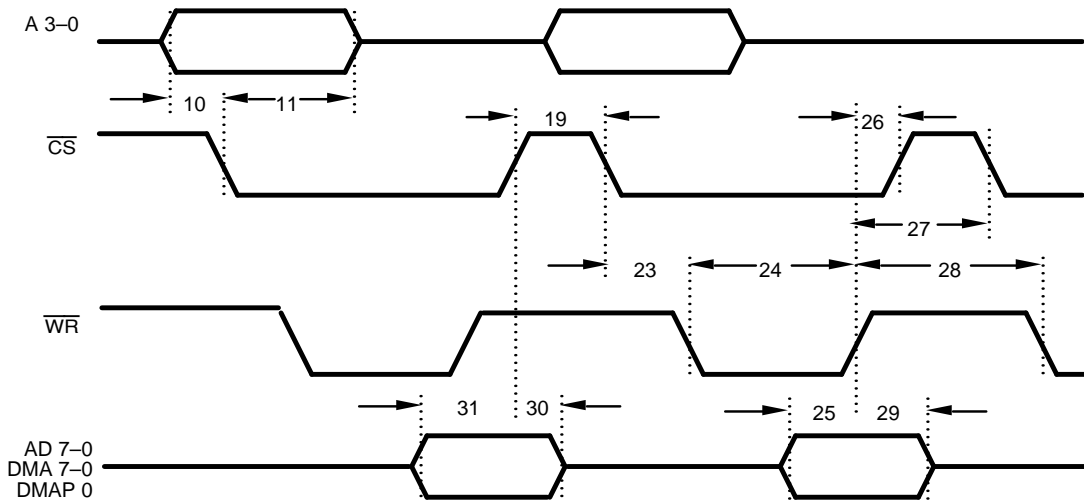

17348B-41

Register Write with Non-Multiplexed Address Data Bus

Register Read/Write with Non-Multiplexed Address Data Bus

No.	Parameter Symbol	Parameter Description	Test Conditions	Min	Max	Unit
10	ts	Address to \overline{CS} \downarrow Set Up Time		0		ns
11	tH	Address to \overline{CS} \downarrow Hold Time		30		ns
12	ts	\overline{CS} \downarrow to \overline{RD} \downarrow Set Up Time		0		ns
13	tPD	\overline{CS} \downarrow to Data Valid Delay			65	ns
14	tPWL	\overline{RD} Pulse Width Low		30		ns
15	tPD	\overline{RD} \downarrow to Data Valid Delay			30	ns
16	tH	\overline{RD} \uparrow to \overline{CS} \uparrow Hold Time		0		ns
17	tz	\overline{RD} \uparrow to Data High Impedance			30	ns
18	tH	\overline{RD} \uparrow to Data Hold Time		2		ns
19	tPWH	\overline{CS} Pulse Width High		30		ns
20	ts	\overline{RD} \uparrow to \overline{CS} \downarrow Set Up Time		40		ns
21	tH	\overline{CS} \uparrow to Data Hold Time		2		ns
22	tz	\overline{CS} \uparrow to Data High Impedance			30	ns
23	ts	\overline{CS} \downarrow to \overline{WR} \downarrow Set Up Time		0		ns
24	tPWL	\overline{WR} Pulse Width Low		30		ns
25	ts	Data to \overline{WR} \uparrow Set Up Time		15		ns
26	tH	\overline{WR} \uparrow to \overline{CS} \uparrow Hold Time		0		ns
27	ts	\overline{WR} \uparrow to \overline{CS} \downarrow Set Up Time		30		ns
28	tPWH	\overline{WR} Pulse Width High		40		ns
29	tH	Data to \overline{WR} \uparrow Hold Time		0		ns
30	tH	\overline{CS} \uparrow to Data Hold		30		ns
31	ts	Data to \overline{CS} \uparrow Setup Time		10		ns

Note:

There is a one-to-one relationship between every AMD and Emulex Parameter (refer to Appendix B).

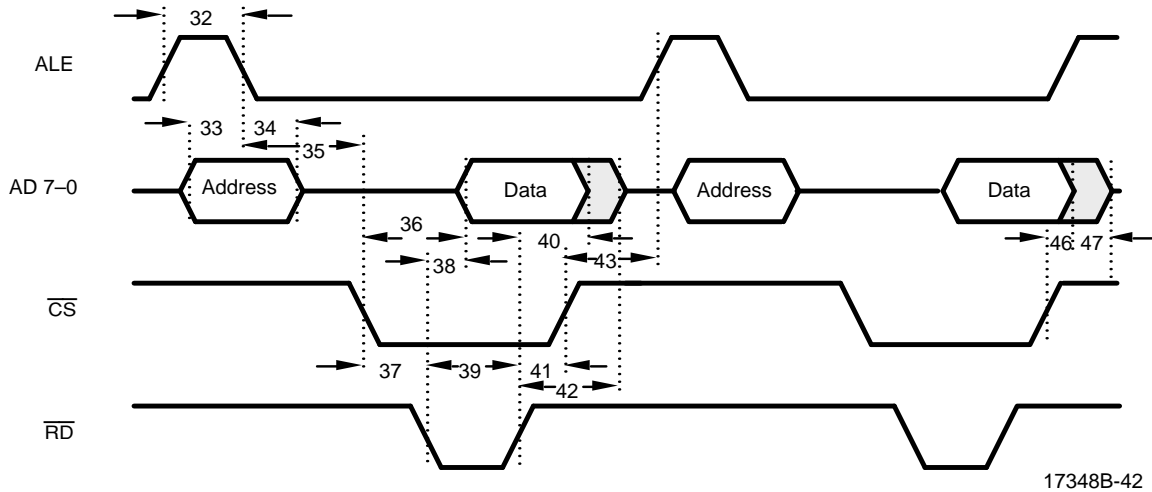

Register Read with Multiplexed Address Data Bus

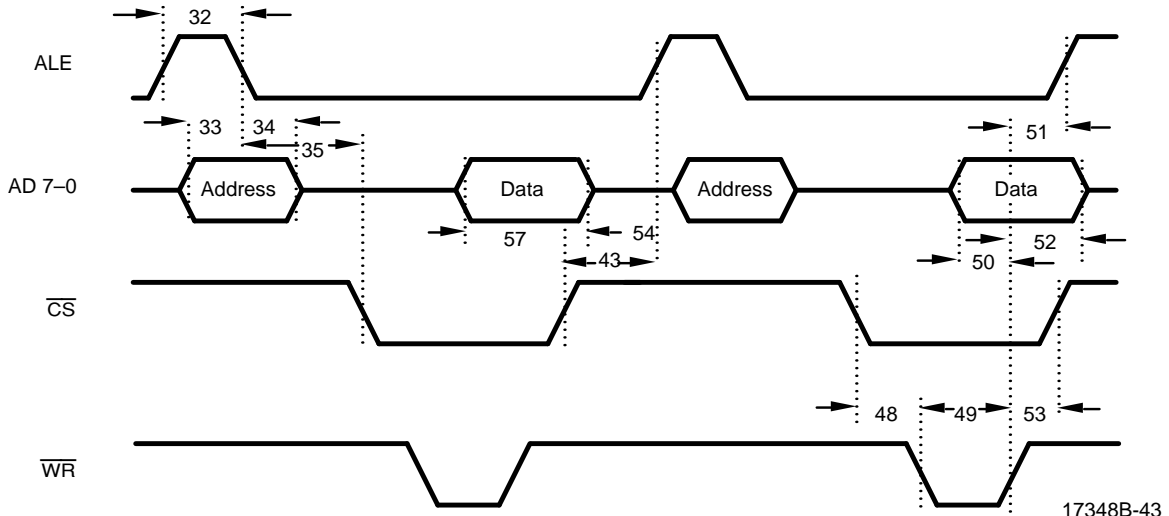

Register Write with Multiplexed Address Data Bus

Register Read/Write with Multiplexed Address Data Bus

No.	Parameter Symbol	Parameter Description	Test Conditions	Min	Max	Unit
32	t _{PWH}	ALE Pulse Width High		20		ns
33	t _s	Address to ALE \downarrow Set Up Time		10		ns
34	t _H	Address to ALE \downarrow Hold Time		10		ns
35	t _s	ALE \downarrow to \overline{CS} \downarrow Set Up Time		10		ns
36	t _{PD}	\overline{CS} \downarrow to Data Valid Delay			65	ns
37	t _s	\overline{CS} \downarrow to \overline{RD} \downarrow Set Up Time		0		ns
38	t _{PD}	\overline{RD} \downarrow to Data Valid Delay			30	ns
39	t _{PWL}	\overline{RD} Pulse Width Low		30		ns
40	t _H	\overline{RD} \uparrow to Data Hold Time		2		ns
41	t _H	\overline{RD} \uparrow to \overline{CS} \uparrow Hold Time		0		ns
42	t _z	\overline{RD} \uparrow to Data High Impedance			30	ns
43	t _s	\overline{CS} \uparrow to ALE \uparrow Set Up Time		50		ns
44		PARAMETER DOES NOT EXIST				
45		PARAMETER DOES NOT EXIST				
46	t _{PD}	\overline{CS} \uparrow to Data Hold Time		2		ns
47	t _z	\overline{CS} \uparrow to Data High Impedance			30	ns
48	t _s	\overline{CS} \downarrow to \overline{WR} \downarrow Set Up Time		0		ns
49	t _{PWL}	\overline{WR} Pulse Width Low		30		ns
50	t _s	Data to \overline{WR} \uparrow Set Up Time		15		ns
51	t _s	\overline{WR} \uparrow to ALE \uparrow Set Up Time		50		ns
52	t _H	Data to \overline{WR} \uparrow Hold Time		0		ns
53	t _H	\overline{WR} \uparrow to \overline{CS} \uparrow Hold Time		0		ns
54	t _H	\overline{CS} \uparrow to Data Hold Time		30		ns
55		PARAMETER DOES NOT EXIST				
56		PARAMETER DOES NOT EXIST				
57	t _s	Data Setup to \overline{CS} \uparrow		10		ns

Note:

There is a one-to-one relationship between every AMD and Emulex Parameter (refer to Appendix B).

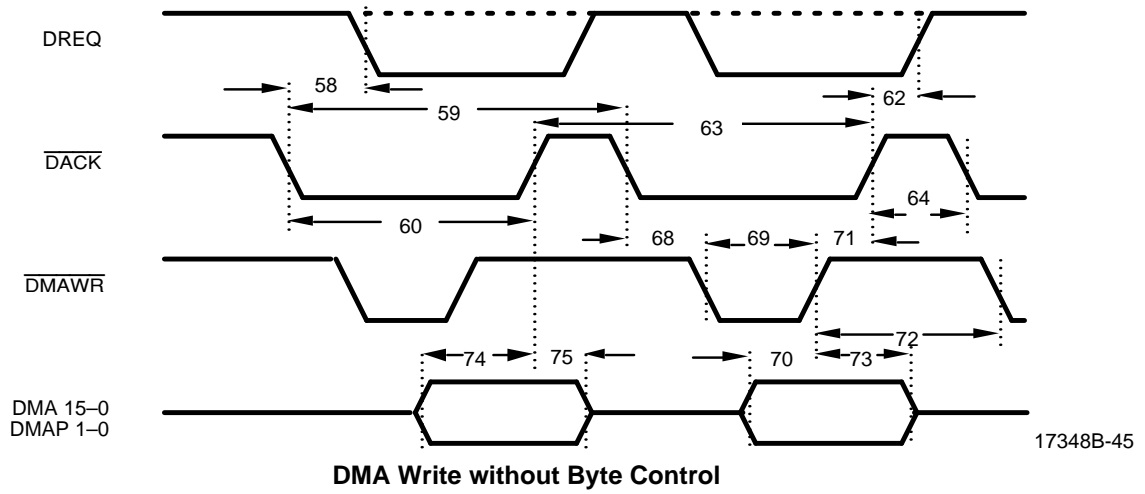
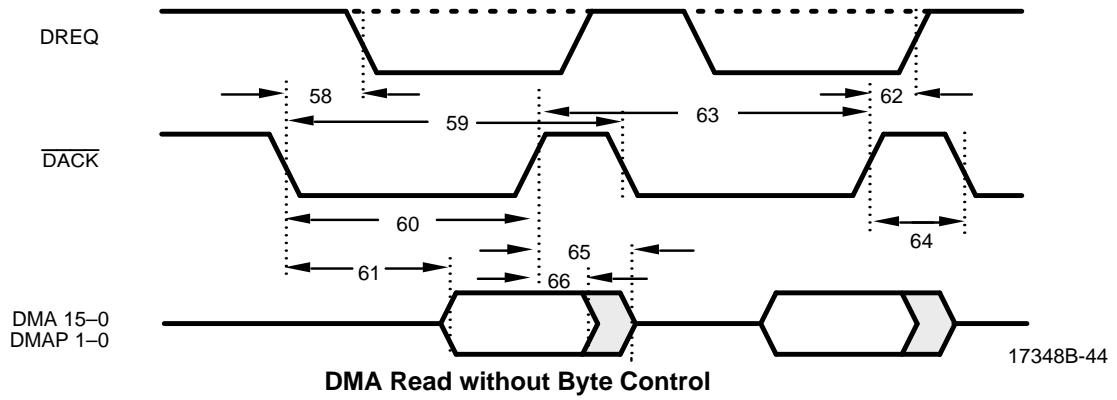

DMA Read/Write without Byte Control

No.	Parameter Symbol	Parameter Description	Test Conditions	Min	Max	Unit
58	t _{PD}	\overline{DACK} \downarrow to \overline{DREQ} \downarrow Valid Delay			30	ns
59	t _P	\overline{DACK} \downarrow to \overline{DACK} \downarrow period		95		ns
60	t _{PWL}	\overline{DACK} Pulse Width Low		45		ns
61	t _{PD}	\overline{DACK} \downarrow to Data Valid Delay			30	ns
62	t _{PD}	\overline{DACK} \uparrow to \overline{DREQ} \uparrow Valid Delay			30	ns
63	t _P	\overline{DACK} \uparrow to \overline{DACK} \uparrow period		t _L +25		ns
64	t _{PWH}	\overline{DACK} Pulse Width High		12		ns
65	t _Z	\overline{DACK} \uparrow to Data High Impedance			25	ns
66	t _H	\overline{DACK} \uparrow to Data Hold Time		2		ns
67		PARAMETER DOES NOT EXIST				
68	t _S	\overline{DACK} \downarrow to \overline{DMAWR} \downarrow Set Up Time		0		ns
69	t _{PWL}	\overline{DMAWR} Pulse Width Low		30		ns
70	t _S	Data to \overline{DMAWR} \uparrow Set Up Time		15		ns
71	t _H	\overline{DMAWR} \uparrow to \overline{DACK} \uparrow Hold Time		0		ns
72	t _{PWH}	\overline{DMAWR} Pulse Width High		25		ns
73	t _H	Data to \overline{DMAWR} \uparrow Hold Time		0		ns
74	t _S	Data to \overline{DACK} \uparrow Set Up Time		10		ns
75	t _H	\overline{DACK} \uparrow to Data Hold Time		10		ns

Note:

There is a one-to-one relationship between every AMD and Emulex Parameter (refer to Appendix B).

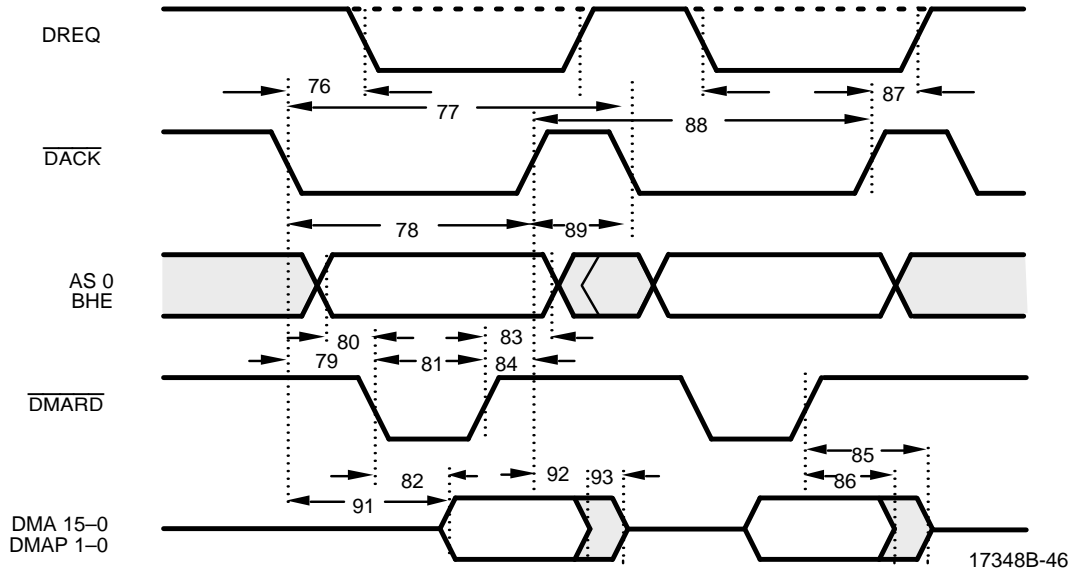

DMA Read with Byte Control

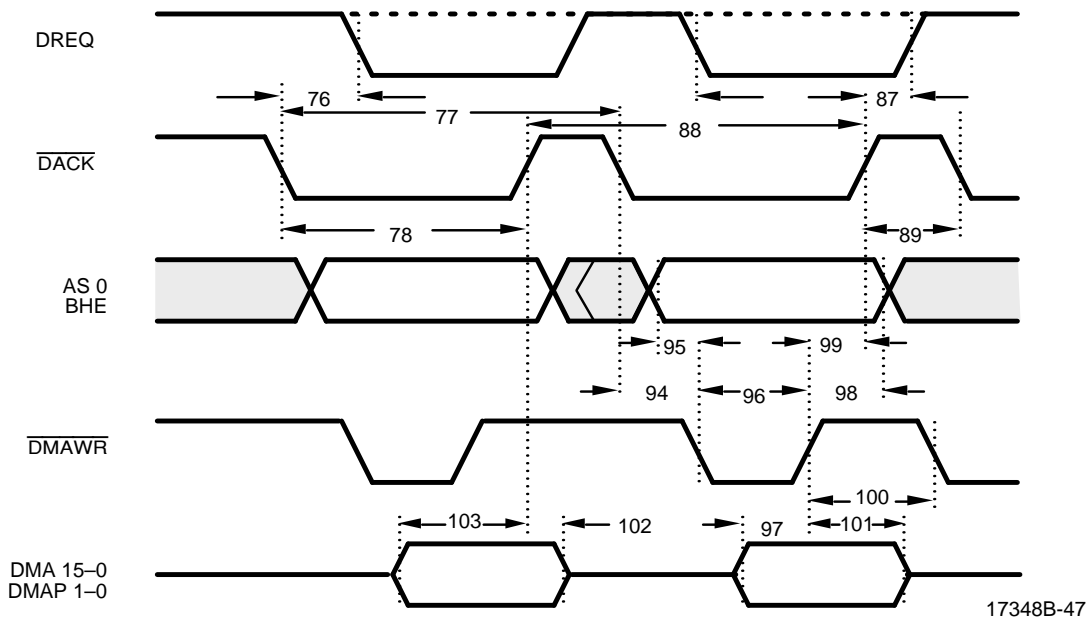

DMA Write with Byte Control

DMA Read/Write with Byte Control

No.	Parameter Symbol	Parameter Description	Test Conditions	Min	Max	Unit
76	t _{PD}	\overline{DACK} \downarrow to \overline{DREQ} \downarrow Valid Delay			30	ns
77	t _P	\overline{DACK} \downarrow to \overline{DACK} \downarrow period		95		ns
78	t _{PWL}	\overline{DACK} Pulse Width Low		45		ns
79	t _s	\overline{DACK} \downarrow to \overline{DMARD} \downarrow Set Up Time		0		ns
80	t _s	BHE, AS0 to \overline{DMARD} \downarrow Set Up Time		20		ns
81	t _{PWL}	\overline{DMARD} Pulse Width Low		35		ns
82	t _{PD}	\overline{DMARD} \downarrow to Data Valid Delay			35	ns
83	t _H	BHE, AS0 to \overline{DMARD} \uparrow Hold Time		20		ns
84	t _H	\overline{DMARD} \uparrow to \overline{DACK} \uparrow Hold Time		0		ns
85	t _z	\overline{DMARD} \uparrow to Data High Impedance			35	ns
86	t _H	\overline{DMARD} \uparrow to Data Hold Time		2		ns
87	t _{PD}	\overline{DACK} \uparrow to \overline{DREQ} \uparrow Valid Delay			30	ns
88	t _P	\overline{DACK} \uparrow to \overline{DACK} \uparrow period		t _L + 25		ns
89	t _{PWH}	\overline{DACK} Pulse Width High		12		ns
90		PARAMETER DOES NOT EXIST				
91	t _{PD}	\overline{DACK} \downarrow to Data Valid Delay			30	ns
92	t _H	\overline{DACK} \uparrow to Data Hold Time		2		ns
93	t _z	\overline{DACK} \uparrow to Data High Impedance			25	ns
94	t _s	\overline{DACK} \downarrow to \overline{DMAWR} \downarrow Set Up Time		0		ns
95	t _s	BHE, AS0 to \overline{DMAWR} \downarrow Set Up Time		20		ns
96	t _{PWL}	\overline{DMAWR} Pulse Width Low		30		ns
97	t _s	Data to \overline{DMAWR} \uparrow Set Up Time		15		ns
98	t _H	BHE, AS0 to \overline{DMAWR} \uparrow Hold Time		20		ns
99	t _H	\overline{DMAWR} \uparrow to \overline{DACK} \uparrow Hold Time		0		ns
100	t _{PWH}	\overline{DMAWR} Pulse Width High		25		ns
101	t _H	Data to \overline{DMAWR} \uparrow Hold Time		0		ns
102	t _H	\overline{DACK} \uparrow to Data Hold Time		10		ns
103	t _s	Data to \overline{DACK} \uparrow Set Up Time		10		ns

Note:

There is a one-to-one relationship between every AMD and Emulex Parameter (refer to Appendix B).

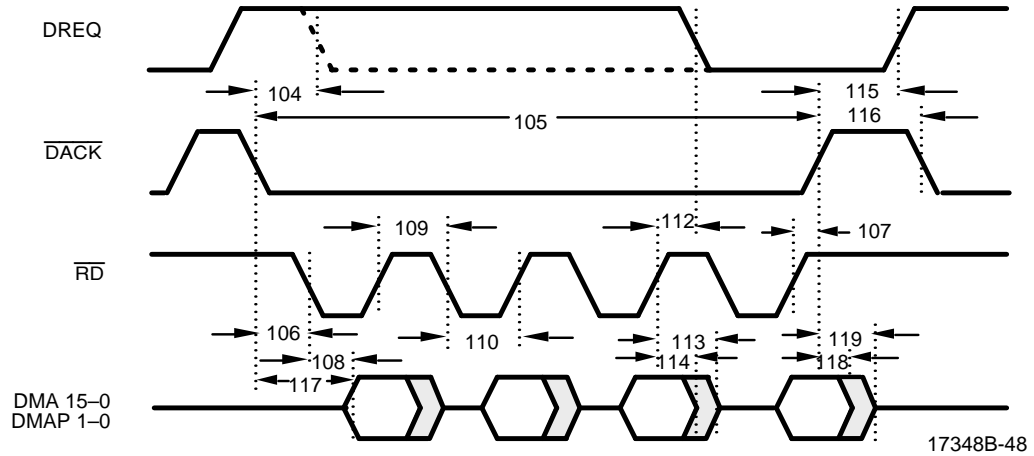

Burst DMA Read without Byte Control—Modes 0 and 1

17348B-48

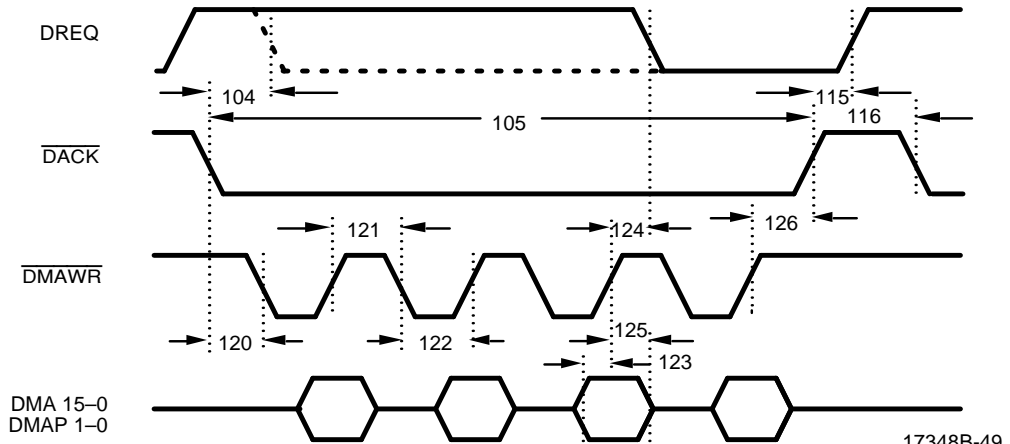

Burst DMA Write without Byte Control—Modes 0 and 1

17348B-49

Burst DMA Read/Write Mode 0, 1

No.	Parameter Symbol	Parameter Description	Test Conditions	Min	Max	Unit
104	t _{PD}	$\overline{\text{DACK}}$ \downarrow to $\overline{\text{DREQ}}$ \downarrow Valid Delay			30	ns
105	t _{PWL}	$\overline{\text{DACK}}$ Pulse Width Low		70		ns
106	t _S	$\overline{\text{DACK}}$ \downarrow to $\overline{\text{RD}}$ \downarrow Set Up Time		0		ns
107	t _P	$\overline{\text{RD}}$ \uparrow to $\overline{\text{DACK}}$ \uparrow Hold Time		0		ns
108	t _{PD}	$\overline{\text{RD}}$ \downarrow to Data Valid Delay			55	ns
109	t _{PWH}	$\overline{\text{RD}}$ Pulse Width High		60		ns
110	t _{PWL}	$\overline{\text{RD}}$ Pulse Width Low		70		ns
111		PARAMETER DOES NOT EXIST				
112	t _{PD}	$\overline{\text{RD}}$ \uparrow to $\overline{\text{DREQ}}$ \downarrow Valid Delay			90	ns
113	t _Z	$\overline{\text{RD}}$ \uparrow to Data High Impedance			45	ns
114	t _H	$\overline{\text{RD}}$ \uparrow to Data Hold Time		2		ns
115	t _{PD}	$\overline{\text{DACK}}$ \uparrow to $\overline{\text{DREQ}}$ \uparrow Valid Delay			30	ns
116	t _{PWH}	$\overline{\text{DACK}}$ Pulse Width High		60		ns
117	t _{PD}	$\overline{\text{DACK}}$ \downarrow to Data Valid Delay			35	ns
118	t _H	$\overline{\text{DACK}}$ \uparrow to Data Hold Time		2		ns
119	t _Z	$\overline{\text{DACK}}$ \uparrow to Data High Impedance			25	ns
120	t _S	$\overline{\text{DACK}}$ \downarrow to $\overline{\text{DMAWR}}$ \downarrow Set Up Time		0		ns
121	t _{PWH}	$\overline{\text{DMAWR}}$ Pulse Width High		60		ns
122	t _{PWL}	$\overline{\text{DMAWR}}$ Pulse Width Low		70		ns
123	t _S	Data to $\overline{\text{DMAWR}}$ \uparrow Set Up Time		15		ns
124	t _{PD}	$\overline{\text{DMAWR}}$ \uparrow to $\overline{\text{DREQ}}$ \downarrow Valid Delay			90	ns
125	t _H	Data to $\overline{\text{DMAWR}}$ \uparrow Hold Time		0		ns
126	t _H	$\overline{\text{DMAWR}}$ \uparrow to $\overline{\text{DACK}}$ \uparrow Hold Time		0		ns

Note:

There is a one-to-one relationship between every AMD and Emulex Parameter (refer to Appendix B).

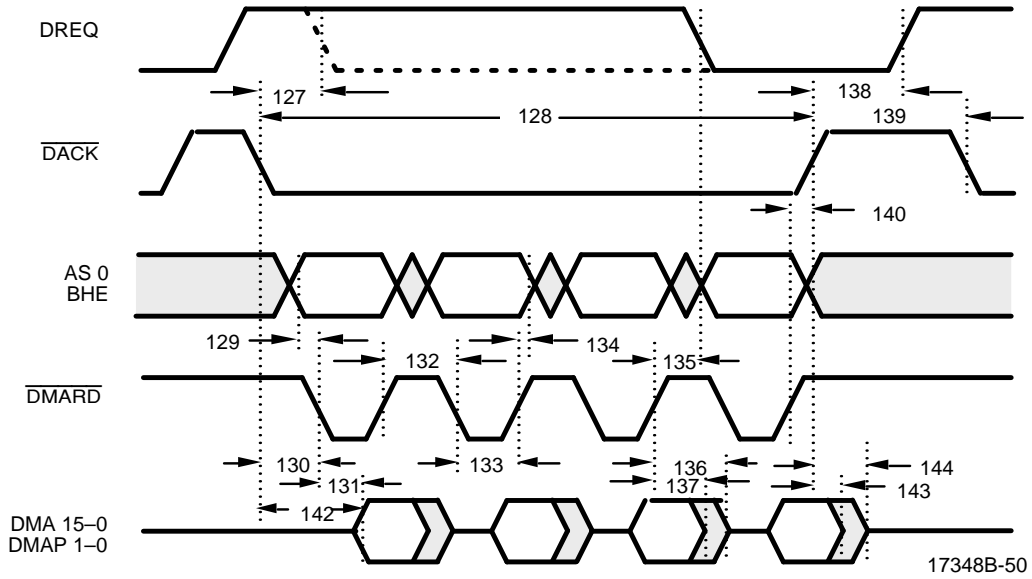

Burst DMA Read with Byte Control—Mode 2

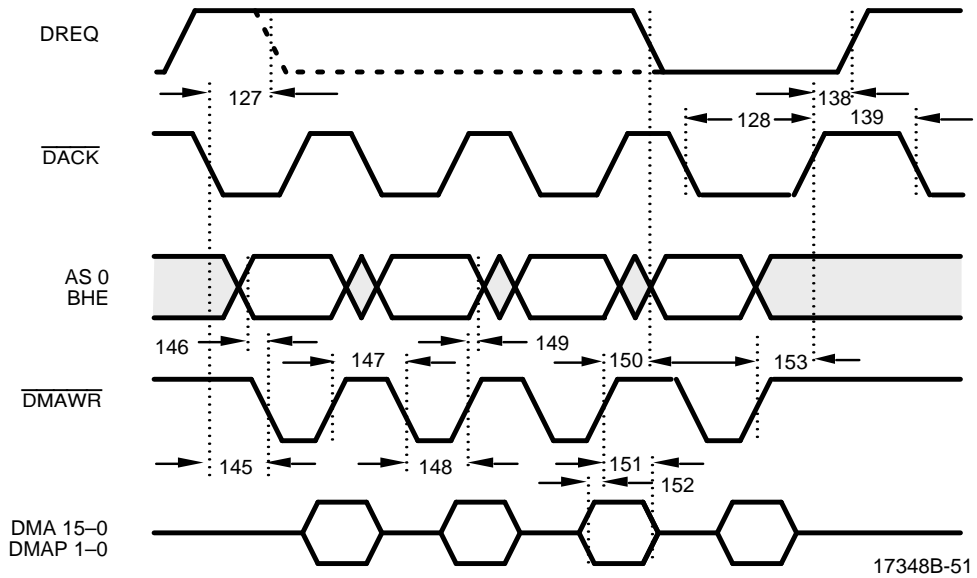

Burst DMA Write with Byte Control—Mode 2

Burst DMA–Mode 2

No.	Parameter Symbol	Parameter Description	Test Conditions	Min	Max	Unit
127	t _{PD}	\overline{DACK} \downarrow to \overline{DREQ} \downarrow Valid Delay			30	ns
128	t _{PWL}	\overline{DACK} Pulse Width Low		70		ns
129	t _s	BHE, AS0 to \overline{DMARD} \downarrow Set Up Time		20		ns
130	t _s	\overline{DACK} \downarrow to \overline{DMARD} \downarrow Set Up Time		0		ns
131	t _{PD}	\overline{DMARD} \downarrow to Data Valid Delay			55	ns
132	t _{PWH}	\overline{DMARD} Pulse Width High		60		ns
133	t _{PWL}	\overline{DMARD} Pulse Width Low		70		ns
134	t _H	BHE, AS0 to \overline{DMARD} \uparrow Hold Time		20		ns
135	t _{PD}	\overline{DMARD} \uparrow to \overline{DREQ} \downarrow Valid Delay			90	ns
136	t _z	\overline{DMARD} \uparrow to Data High Impedance			45	ns
137	t _H	\overline{DMARD} \uparrow to Data Hold Time		2		ns
138	t _{PD}	\overline{DACK} \uparrow to \overline{DREQ} \uparrow Valid Delay			30	ns
139	t _{PWH}	\overline{DACK} Pulse Width High		60		ns
140	t _H	\overline{DMARD} \uparrow to \overline{DACK} \uparrow Hold Time		0		ns
141		PARAMETER DOES NOT EXIST				
142	t _{PD}	\overline{DACK} \downarrow to Data Valid Delay			35	ns
143	t _H	\overline{DACK} \uparrow to Data Hold Time		2		ns
144	t _z	\overline{DACK} \uparrow to Data High Impedance			25	ns
145	t _s	\overline{DACK} \downarrow to \overline{DMAWR} \downarrow Set Up Time		0		ns
146	t _s	BHE, AS0 to \overline{DMAWR} \downarrow Set Up Time		20		ns
147	t _{PWH}	\overline{DMAWR} Pulse Width High		60		ns
148	t _{PWL}	\overline{DMAWR} Pulse Width Low		70		ns
149	t _H	BHE, AS0 to \overline{DMAWR} \uparrow Hold Time		20		ns
150	t _{PD}	\overline{DMAWR} \uparrow to \overline{DREQ} \downarrow Valid Delay			90	ns
151	t _H	Data to \overline{DMAWR} \uparrow Hold Time		0		ns
152	t _s	Data to \overline{DMAWR} \uparrow Set Up Time		15		ns
153	t _H	\overline{DMAWR} \uparrow to \overline{DACK} \uparrow Hold Time		0		ns

Note:

There is a one-to-one relationship between every AMD and Emulex Parameter (refer to Appendix B).

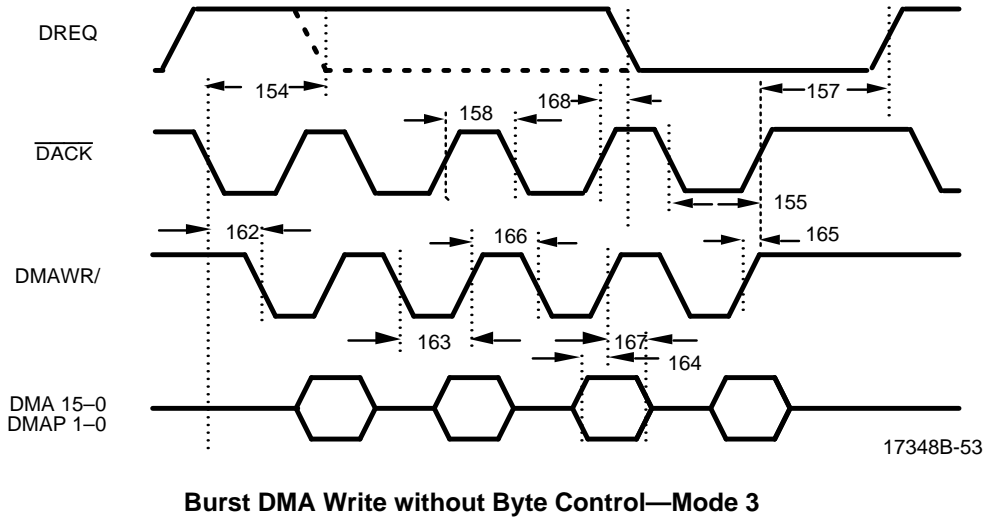
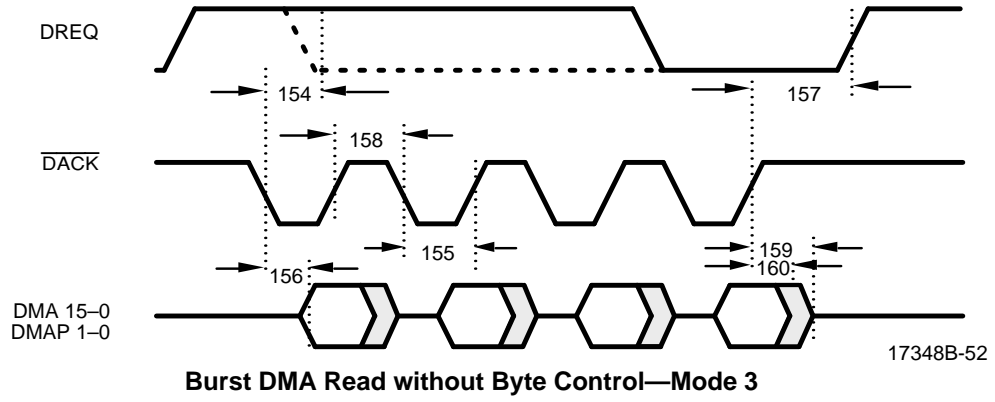

Burst DMA Mode 3

No.	Parameter Symbol	Parameter Description	Test Conditions	Min	Max	Unit
154	t _{PD}	$\overline{\text{DACK}} \downarrow$ to $\overline{\text{DREQ}} \downarrow$ Valid Delay			30	ns
155	t _{PWL}	$\overline{\text{DACK}}$ Pulse Width Low		70		ns
156	t _{PD}	$\overline{\text{DACK}} \downarrow$ to Data Valid Delay			35	ns
157	t _{PD}	$\overline{\text{DACK}} \uparrow$ to $\overline{\text{DREQ}} \uparrow$ Valid Delay			30	ns
158	t _{PWH}	$\overline{\text{DACK}}$ Pulse Width High		60		ns
159	t _z	$\overline{\text{DACK}} \uparrow$ to Data High Impedance			25	ns
160	t _H	$\overline{\text{DACK}} \uparrow$ to Data Hold Time		2		ns
161		PARAMETER DOES NOT EXIST				
162	t _s	$\overline{\text{DACK}} \downarrow$ to $\overline{\text{DMAWR}} \downarrow$ Set Up Time		0		ns
163	t _{PWL}	$\overline{\text{DMAWR}}$ Pulse Width Low		70		ns
164	t _s	Data to $\overline{\text{DMAWR}} \uparrow$ Set Up Time		15		ns
165	t _H	$\overline{\text{DMAWR}} \uparrow$ to $\overline{\text{DACK}} \uparrow$ Hold Time		0		ns
166	t _{PWH}	$\overline{\text{DMAWR}}$ Pulse Width High		60		ns
167	t _H	Data to $\overline{\text{DMAWR}} \uparrow$ Hold Time		0		ns
168	t _{PD}	$\overline{\text{DACK}} \uparrow$ to $\overline{\text{DREQ}} \downarrow$ Valid Delay			90	ns

Note:

There is a one-to-one relationship between every AMD and Emulex Parameter (refer to Appendix B).

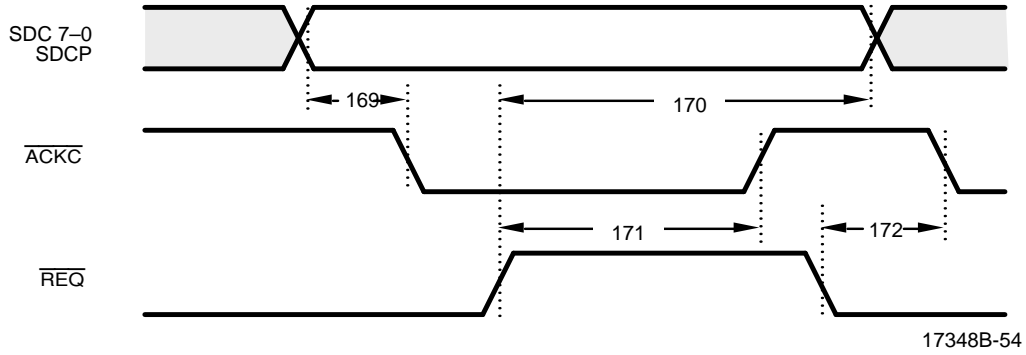

17348B-54

Asynchronous Initiator Send

Single Ended:

No.	Parameter Symbol	Parameter Description	Test Conditions	Min	Max	Unit
169	ts	Data to $\overline{\text{ACKC}}$ \downarrow Set Up Time		60		ns
170	t _{PD}	$\overline{\text{REQ}}$ \uparrow to Data Delay		5		ns
171	t _{PD}	$\overline{\text{REQ}}$ \uparrow to $\overline{\text{ACKC}}$ \uparrow Delay			50	ns
172	t _{PD}	$\overline{\text{REQ}}$ \downarrow to $\overline{\text{ACKC}}$ \downarrow Delay			50	ns

Differential:

No.	Parameter Symbol	Parameter Description	Test Conditions	Min	Max	Unit
169	ts	Data to $\overline{\text{ACKC}}$ \downarrow Set Up Time		70		ns
170	t _{PD}	$\overline{\text{REQ}}$ \uparrow to Data Delay		5		ns
171	t _{PD}	$\overline{\text{REQ}}$ \uparrow to $\overline{\text{ACKC}}$ \uparrow Delay			25	ns
172	t _{PD}	$\overline{\text{REQ}}$ \downarrow to $\overline{\text{ACKC}}$ \downarrow Delay			30	ns

Note:

There is a one-to-one relationship between every AMD and Emulex Parameter (refer to Appendix B).

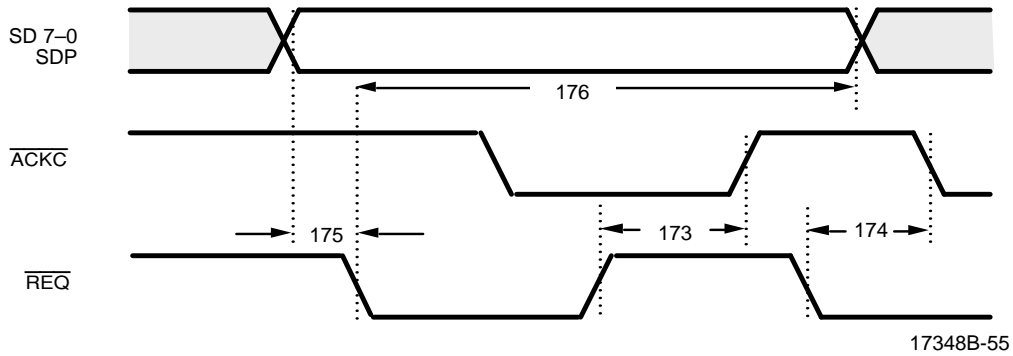

Asynchronous Initiator Receive

17348B-55

Single Ended:

No.	Parameter Symbol	Parameter Description	Test Conditions	Min	Max	Unit
173	t_{PD}	$\overline{REQ} \uparrow$ to $\overline{ACKC} \uparrow$ Delay			50	ns
174	t_{PD}	$\overline{REQ} \downarrow$ to $\overline{ACKC} \downarrow$ Delay			50	ns
175	t_s	Data to $\overline{REQ} \downarrow$ Set Up Time		0		ns
176	t_H	$\overline{REQ} \downarrow$ to Data Hold Time		18		ns

Differential:

No.	Parameter Symbol	Parameter Description	Test Conditions	Min	Max	Unit
173	t_{PD}	$\overline{REQ} \uparrow$ to $\overline{ACKC} \uparrow$ Delay			25	ns
174	t_{PD}	$\overline{REQ} \downarrow$ to $\overline{ACKC} \downarrow$ Delay			30	ns
175	t_s	Data to $\overline{REQ} \downarrow$ Set Up Time		0		ns
176	t_H	$\overline{REQ} \downarrow$ to Data Hold Time		18		ns

Note:

There is a one-to-one relationship between every AMD and Emulex Parameter (refer to Appendix B).

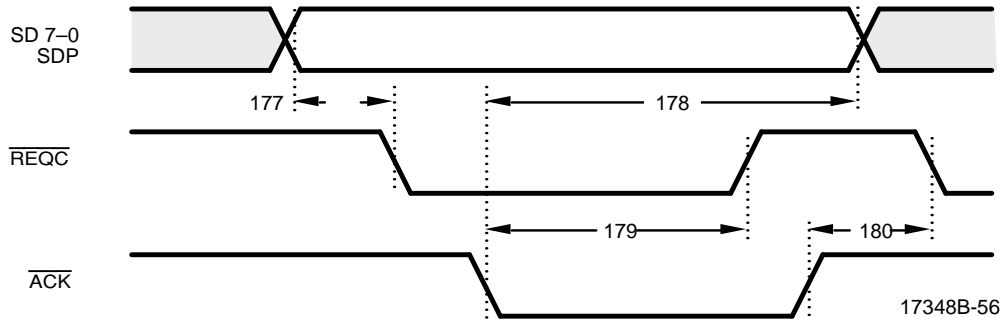

Asynchronous Target Send

Single Ended:

No.	Parameter Symbol	Parameter Description	Test Conditions	Min	Max	Unit
177	t_s	Data to \overline{REQC} \downarrow Set Up Time		60		ns
178	t_H	\overline{ACK} \downarrow to Data Hold Time		5		ns
179	t_{PD}	\overline{ACK} \downarrow to \overline{REQC} \uparrow Delay			50	ns
180	t_{PD}	\overline{ACK} \uparrow to \overline{REQC} \downarrow Delay			45	ns

Differential:

No.	Parameter Symbol	Parameter Description	Test Conditions	Min	Max	Unit
177	t_s	Data to \overline{REQC} \downarrow Set Up Time		70		ns
178	t_H	\overline{ACK} \downarrow to Data Hold Time		5		ns
179	t_{PD}	\overline{ACK} \downarrow to \overline{REQC} \uparrow Delay			30	ns
180	t_{PD}	\overline{ACK} \uparrow to \overline{REQC} \downarrow Delay			30	ns

Note:

There is a one-to-one relationship between every AMD and Emulex Parameter (refer to Appendix B).

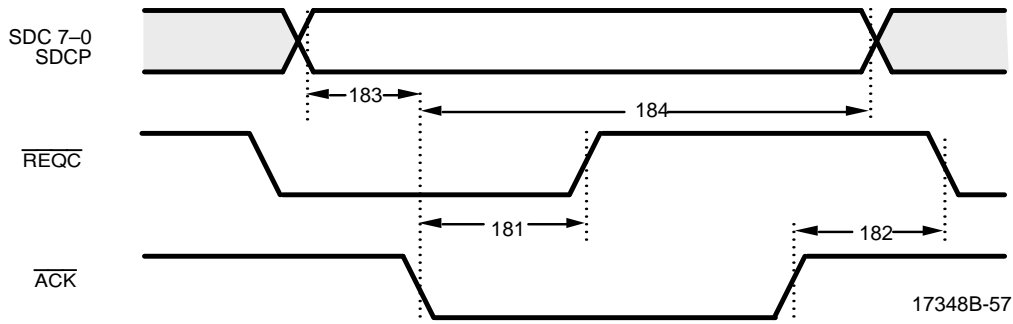

Asynchronous Target Receive

Single Ended:

No.	Parameter Symbol	Parameter Description	Test Conditions	Min	Max	Unit
181	t _{PD}	$\overline{ACK} \downarrow$ to $\overline{REQC} \uparrow$ Delay			50	ns
182	t _{PD}	$\overline{ACK} \uparrow$ to $\overline{REQC} \downarrow$ Delay			45	ns
183	t _s	Data to $\overline{ACK} \downarrow$ Set Up Time		0		ns
184	t _H	$\overline{ACK} \downarrow$ to Data Hold Time		18		ns

Differential:

No.	Parameter Symbol	Parameter Description	Test Conditions	Min	Max	Unit
181	t _{PD}	$\overline{ACK} \downarrow$ to $\overline{REQC} \uparrow$ Delay			30	ns
182	t _{PD}	$\overline{ACK} \uparrow$ to $\overline{REQC} \downarrow$ Delay			30	ns
183	t _s	Data to $\overline{ACK} \downarrow$ Set Up Time		0		ns
184	t _H	$\overline{ACK} \downarrow$ to Data Hold Time		18		ns

Note:

There is a one-to-one relationship between every AMD and Emulex Parameter (refer to Appendix B).

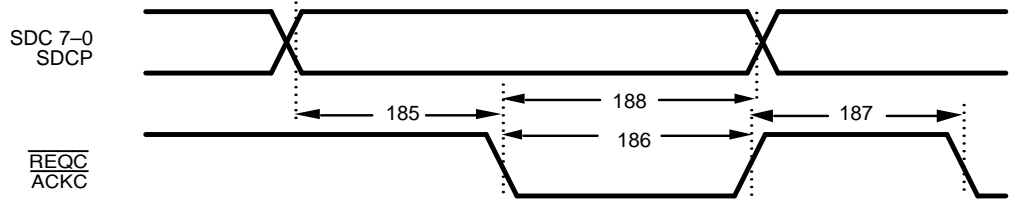

Synchronous Initiator Target Transmit

17348B-58

Normal SCSI: (Single Ended)

No.	Parameter Symbol	Parameter Description	Test Conditions	Min	Max	Unit
185	ts	ACKC or REQC \downarrow to Data Set Up Time		55		ns
186	tpWL	REQC or ACKC Pulse Width Low		90		ns
187	tpWH	REQC or ACKC Pulse Width High		90		ns
188	tH	ACKC or REQC \downarrow to Data Hold Time		100		ns

Fast SCSI: (Single Ended)

No.	Parameter Symbol	Parameter Description	Test Conditions	Min	Max	Unit
185	ts	ACKC or REQC \downarrow to Data Set Up Time		25		ns
186	tpWL	REQC or ACKC Pulse Width Low		30		ns
187	tpWH	REQC or ACKC Pulse Width High		30		ns
188	tH	ACKC or REQC \downarrow to Data Hold Time		35		ns

Normal SCSI: (Differential)

No.	Parameter Symbol	Parameter Description	Test Conditions	Min	Max	Unit
185	ts	ACKC or REQC \downarrow to Data Set Up Time		65		ns
186	tpWL	REQC or ACKC Pulse Width Low		96		ns
187	tpWH	REQC or ACKC Pulse Width High		96		ns
188	tH	ACKC or REQC \downarrow to Data Hold Time		110		ns

Fast SCSI: (Differential)

No.	Parameter Symbol	Parameter Description	Test Conditions	Min	Max	Unit
185	ts	ACKC or REQC \downarrow to Data Set Up Time		35		ns
186	tpWL	REQC or ACKC Pulse Width Low		40		ns
187	tpWH	REQC or ACKC Pulse Width High		40		ns
188	tH	ACKC or REQC \downarrow to Data Hold Time		45		ns

* The minimum values have a wide range since they depend on the Synchronization latency. The synchronization latency, in turn, depends on the operating frequency of the device.

Note:

There is a one-to-one relationship between every AMD and Emulex Parameter (refer to Appendix B).

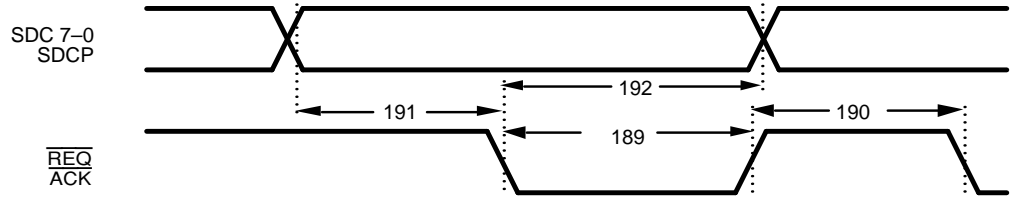

Synchronous Initiator Target Receive

No.	Parameter Symbol	Parameter Description	Test Conditions	Min	Max	Unit
189	t _{PWL}	$\overline{\text{REQ}}$ Pulse Width Low		27		ns
189	t _{PWL}	$\overline{\text{ACK}}$ Pulse Width Low		20		ns
190	t _{PWH}	$\overline{\text{REQ}}$ Pulse Width High		20		ns
190	t _{PWH}	$\overline{\text{ACK}}$ Pulse Width High		20		ns
191	t _s	Data to $\overline{\text{REQ}}$ or $\overline{\text{ACK}}$ Set Up Time		5		ns
192	t _h	$\overline{\text{REQ}}$ or $\overline{\text{ACK}}$ to Data Hold Time		15		ns

Note:

There is a one-to-one relationship between every AMD and Emulex Parameter (refer to Appendix B).

APPENDIX A
Pin Connection Cross Reference for Am53CF94

Pin#	AMD	Emulex	Pin#	AMD	Emulex
1	DMAPO	DBP0	43	$\overline{\text{RSTC}}$	RSTON
2	V _{SS}	V _{SS}	44	V _{SS}	V _{SS}
3	DMA8	DB8	45	$\overline{\text{SEL}}$	SELIN
4	DMA9	DB9	46	$\overline{\text{BSY}}$	BSYIN
5	DMA10	DB10	47	$\overline{\text{REQ}}$	REQIN
6	DMA11	DB11	48	$\overline{\text{ACK}}$	ACKIN
7	DMA12	DB12	49	$\overline{\text{RST}}$	RSTIN
8	DMA13	DB13	50	BUSMD 1	MODE 1
9	DMA14	DB14	51	BUSMD 0	MODE 0
10	DMA15	DB15	52	$\overline{\text{INT}}$	INTN
11	DMAP1	DBP1	53	RESET	RESET
12	$\overline{\text{SD0}}$	SDI0N	54	$\overline{\text{WR}}$	WRN
13	$\overline{\text{SD1}}$	SDI1N	55	$\overline{\text{RD}}$	RDN
14	$\overline{\text{SD2}}$	SDI2N	56	$\overline{\text{CS}}$	CSN
15	$\overline{\text{SD3}}$	SDI3N	57	ASO [A0]	A0/SA0
16	$\overline{\text{SD4}}$	SDI4N	58	BHE [A1]	A1/BHE
17	$\overline{\text{SD5}}$	SDI5N	59	$\overline{\text{DMARD}}$ [A2]	A2/DBRDN
18	$\overline{\text{SD6}}$	SDI6N	60	ALE [A3]	A3/ALE
19	$\overline{\text{SD7}}$	SDI7N	61	CLK	CK
20	$\overline{\text{SDP}}$	SDIPN	62	V _{DD}	V _{DD}
21	V _{DD}	V _{DD}	63	AD0	PAD0
22	V _{SS}	V _{SS}	64	AD1	PAD1
23	$\overline{\text{SDC0}}$	SDO0N	65	AD2	PAD2
24	$\overline{\text{SDC1}}$	SDO1N	66	AD3	PAD3
25	$\overline{\text{SDC2}}$	SDO2N	67	V _{SS}	V _{SS}
26	$\overline{\text{SDC3}}$	SDO3N	68	AD4	PAD4
27	V _{SS}	V _{SS}	69	AD5	PAD5
28	$\overline{\text{SDC4}}$	SDO4N	70	AD6	PAD6
29	$\overline{\text{SDC5}}$	SDO5N	71	AD7	PAD7
30	$\overline{\text{SDC6}}$	SDO6N	72	DREQ	DREQ
31	$\overline{\text{SDC7}}$	SDO7N	73	$\overline{\text{DACK}}$	DACKN
32	$\overline{\text{SDCP}}$	SDOPN	74	$\overline{\text{DMAWR}}$	DBWRN
33	V _{SS}	V _{SS}	75	V _{SS}	V _{SS}
34	$\overline{\text{SELC}}$	SELON	76	V _{SS}	V _{SS}
35	$\overline{\text{BSYC}}$	BSYON	77	DMA0	DB0
36	$\overline{\text{REQC}}$	REQON	78	DMA1	DB1
37	$\overline{\text{ACKC}}$	ACKON	79	DMA2	DB2
38	V _{SS}	V _{SS}	80	DMA3	DB3
39	$\overline{\text{MSG}}$	MSGION	81	DMA4	DB4
40	$\overline{\text{C/D}}$	CDION	82	DMA5	DB5
41	$\overline{\text{I/O}}$	IOION	83	DMA6	DB6
42	$\overline{\text{ATN}}$	ATNION	84	DMA7	DB7

APPENDIX A

Pin Connection Cross Reference for Am53CF96

Pin#	AMD	Emulex	Pin#	AMD	Emulex
1	$\overline{\text{DACK}}$	DACKN	51	$\overline{\text{SDC 7}}$	SDO7N
2	$\overline{\text{DMAWR}}$	DBWRN	52	$\overline{\text{SDC P}}$	SDOPN
3	NC	NC	53	NC	NC
4	ISEL	IGS	54	V _{ss}	V _{ss}
5	V _{ss}	V _{ss}	55	V _{ss}	V _{ss}
6	TSEL	TGS	56	$\overline{\text{SELC}}$	SELON
7	V _{ss}	V _{ss}	57	$\overline{\text{BSYC}}$	BSYON
8	DMA0	DB0	58	$\overline{\text{REQC}}$	REQON
9	DMA1	DB1	59	$\overline{\text{ACKC}}$	ACKON
10	DMA2	DB2	60	V _{ss}	V _{ss}
11	DMA3	DB3	61	V _{ss}	V _{ss}
12	DMA4	DB4	62	$\overline{\text{MSG}}$	MSGION
13	DMA5	DB5	63	$\overline{\text{C/D}}$	CDION
14	DMA6	DB6	64	$\overline{\text{I/O}}$	IOION
15	DMA7	DB7	65	$\overline{\text{ATN}}$	ATNION
16	DMAPO	DBP0	66	$\overline{\text{RSTC}}$	RSTON
17	V _{ss}	V _{ss}	67	V _{ss}	V _{ss}
18	V _{ss}	V _{ss}	68	V _{ss}	V _{ss}
19	DMA8	DB8	69	$\overline{\text{SEL}}$	SELIN
20	DMA9	DB9	70	$\overline{\text{BSY}}$	BSYIN
21	DMA10	DB10	71	$\overline{\text{REQ}}$	REQIN
22	DMA11	DB11	72	$\overline{\text{ACK}}$	ACKIN
23	DMA12	DB12	73	$\overline{\text{RST}}$	RSTIN
24	DMA13	DB13	74	BUSMD 1	MODE 1
25	DMA14	DB14	75	BUSMD 0	MODE 0
26	DMA15	DB15	76	$\overline{\text{INT}}$	INTN
27	DMA15	DB15	77	RESET	RESET
28	NC	NC	78	NC	NC
29	$\overline{\text{SD0}}$	SDI0N	79	$\overline{\text{WR}}$	WRN
30	$\overline{\text{SD1}}$	SDI1N	80	$\overline{\text{RD}}$	RDN
31	$\overline{\text{SD2}}$	SDI2N	81	$\overline{\text{CS}}$	CSN
32	$\overline{\text{SD3}}$	SDI3N	82	ASO [A0]	A0/SA0
33	$\overline{\text{SD4}}$	SDI4N	83	BHE [A1]	A1/BHE
34	$\overline{\text{SD5}}$	SDI5N	84	$\overline{\text{DMARD}}$ [A2]	A2/DBRDN
35	$\overline{\text{SD6}}$	SDI6N	85	ALE [A3]	A3/ALE
36	$\overline{\text{SD7}}$	SDI7N	86	CLK	CK
37	$\overline{\text{SDP}}$	SDIPN	87	$\overline{\text{DFMODE}}$	DIFFMN
38	V _{DD}	V _{DD}	88	V _{DD}	V _{DD}
39	NC	NC	89	NC	NC
40	V _{ss}	V _{ss}	90	AD0	PAD0
41	V _{ss}	V _{ss}	91	AD1	PAD1
42	$\overline{\text{SDC0}}$	SDO0N	92	AD2	PAD2
43	$\overline{\text{SDC1}}$	SDO1N	93	AD3	PAD3
44	$\overline{\text{SDC2}}$	SDO2N	94	V _{ss}	V _{ss}
45	$\overline{\text{SDC3}}$	SDO3N	95	V _{ss}	V _{ss}
46	V _{ss}	V _{ss}	96	AD4	PAD4
47	V _{ss}	V _{ss}	97	AD5	PAD5
48	$\overline{\text{SDC4}}$	SDO4N	98	AD6	PAD6
49	$\overline{\text{SDC5}}$	SDO5N	99	AD7	PAD7
50	$\overline{\text{SDC6}}$	SDO6N	100	DREQ	DREQ

APPENDIX B
Emulex to AMD Timing Parameters Cross Reference

Emulex Parameter #	AMD Parameter #	Emulex Parameter #	AMD Parameter #	Emulex Parameter #	AMD Parameter #
Clock Input, Reset Input, Interrupt Output:		DMA Interface Timing:		Alternate DMA Interface Timing: (Continued)	
1	2	1	58, 76	15	118, 143, 160 (min), 119, 144, 159 (max)
2	4	2	62, 87	16	114, 137 (min), 113, 136 (max)
3	1	3	64, 89	17	146
4	5	4	60, 78	18	149
5	7	5	59, 77	19	120, 145, 162
6	9	6	63, 88	20	122, 148, 163
Register Interface Timing:		7	80	21	126, 153, 165
1	10	8	83	22	124, 150, 168
2	11	9	79	23	121, 147, 166
3	33	10	81	24	123, 152, 164
4	34	11	84	25	125, 151, 167
5	32	12	None	Asynchronous Timing:	
6	35	13	61, 91	1	179, 181
7	43	14	82	2	180, 182
8	19	15	66, 92 (min), 65, 93 (max)	3	171, 173
9	12, 37	16	86 (min), 85 (max)	4	172, 174
10	14, 39	17	95	5 (REQON)	177
11	16, 41	18	98	5 (ACKON)	169
12	20	19	68, 94	6 (REQIN)	170
13	13, 36	20	69, 96	6 (ACKIN)	178
14	15, 38	21	71, 99	7 (REQIN)	175
15	21, 46 (min), 22, 47 (max)	22	72, 100	7 (ACKIN)	183
16	18, 40 (min), 17, 42 (max)	23	70, 97	8 (REQIN)	176
17	23, 48	24	73, 101	8 (ACKIN)	184
18	24, 49	25	74, 103	Synchronous Timing:	
19	26, 53	26	75, 102	1	186
20	27	Alternate DMA Interface Timing:		2	187
21	28	1	104, 127, 154	3	185
22	51	2	115, 138, 157	4	188
23	25, 50	3	116, 139, 158	5	189
24	29, 52	4	105, 128, 155	6	190
25	31, 57	5	129	7	189
26	30, 54	6	134	8	190
		7	106, 130	9	191
		8	110, 133	10	192
		9	107, 140		
		10	112, 135		
		11	109, 132		
		12	None		
		13	117, 142, 156		
		14	108, 131		

PHYSICAL DIMENSIONS*
PL 084
Plastic Leaded Chip Carrier (measured in inches)

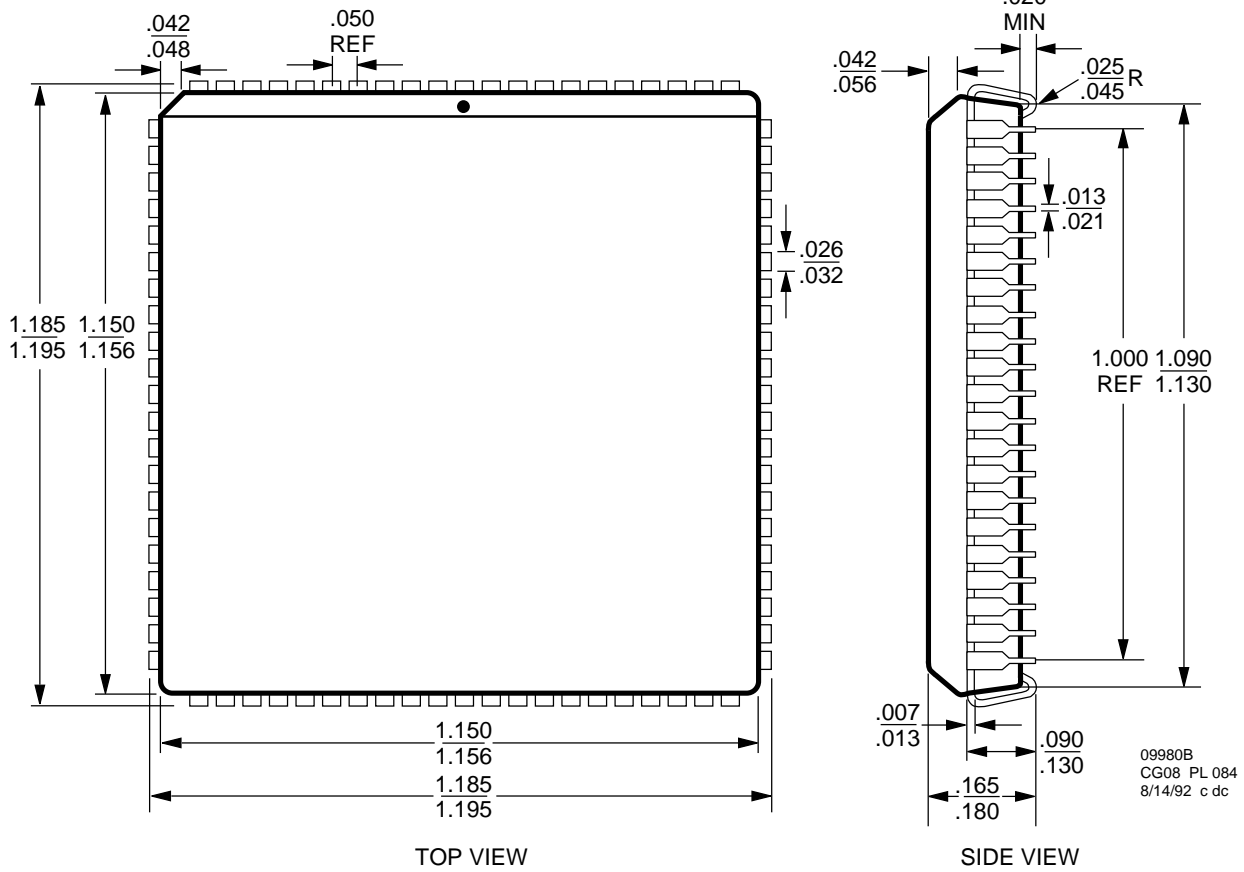

* For reference only. BSC is an ANSI standard for Basic Space Centering.

PHYSICAL DIMENSIONS*
PQR100

Plastic Quad Flatpack Trimmed and Formed (measured in millimeters)

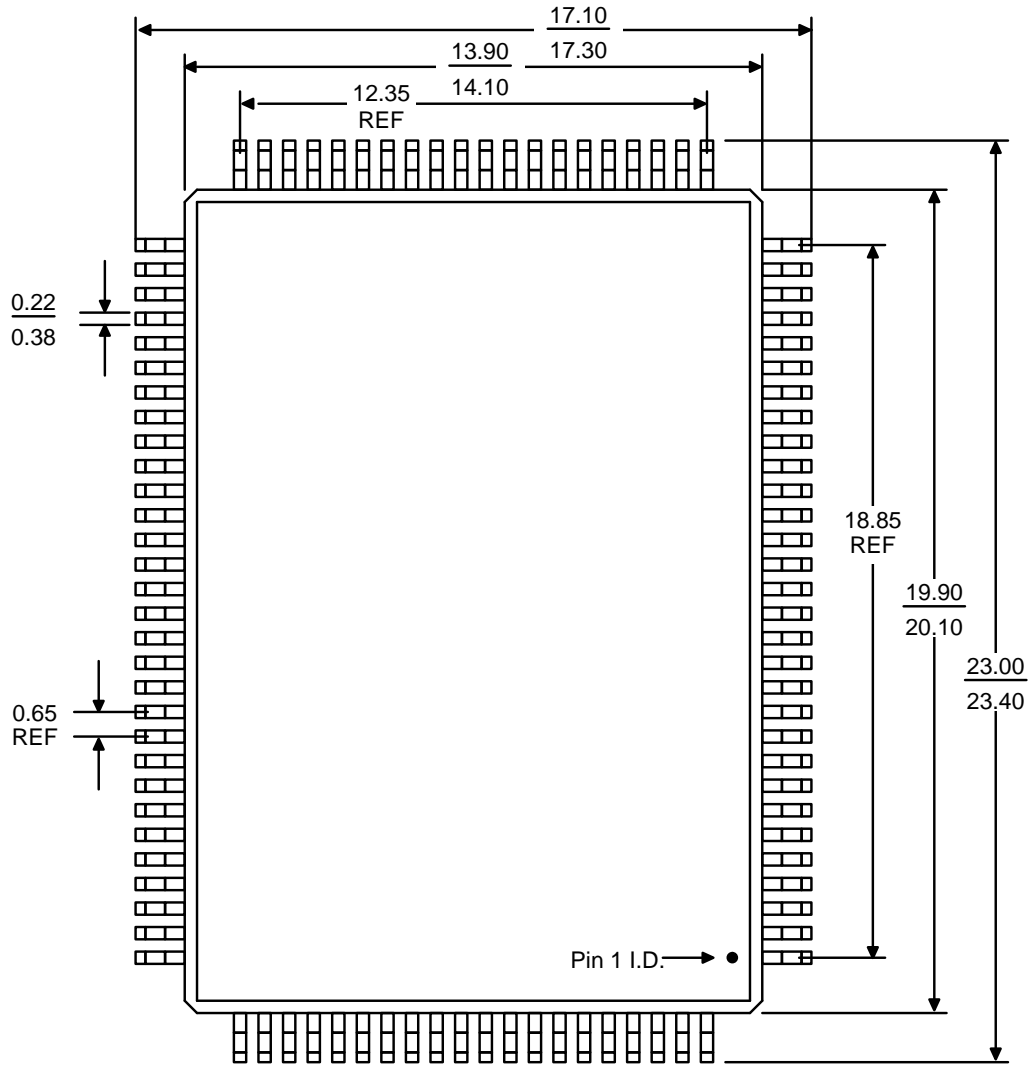

TOP VIEW

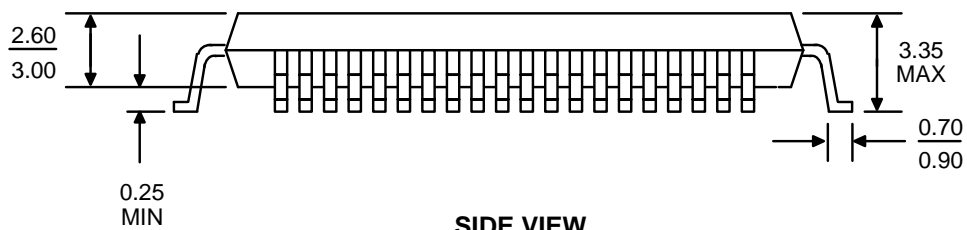

SIDE VIEW

15590D
BX 45
9/6/91 SG

* For reference only. BSC is an ANSI standard for Basic Space Centering.

Trademarks

Copyright © 1993 Advanced Micro Devices. All rights reserved.

AMD and Am386 are registered trademarks of Advanced Micro Devices, Inc.

GLITCH EATER is a trademark of Advanced Micro Devices, Inc.

Product names used in this publication are for identification purposes only and may be trademarks of their respective companies.

This datasheet has been downloaded from:

www.DatasheetCatalog.com

Datasheets for electronic components.



LittleDiode supplies new, hard to find or obsolete electronic components and semiconductors all over the world.

With over two million different components listed you are sure to find the part you need.

Feel free to visit us today at our online store:

LittleDiode.com

Looking forward to providing you with the best possible service.