

TAXIchip™ Integrated Circuits

Transparent Asynchronous
Transmitter/Receiver Interface

Am7968/Am7969-125

Am7968/Am7969-175

Data Sheet
and
Technical Manual

1994



© 1994 Advanced Micro Devices, Inc.

Advanced Micro Devices reserves the right to make changes in its products without notice in order to improve design or performance characteristics.

This publication neither states nor implies any warranty of any kind, including but not limited to implied warrants of merchantability or fitness for a particular application. AMD® assumes no responsibility for the use of any circuitry other than the circuitry in an AMD product.

The information in this publication is believed to be accurate in all respects at the time of publication, but is subject to change without notice. AMD assumes no responsibility for any errors or omissions, and disclaims responsibility for any consequences resulting from the use of the information included herein. Additionally, AMD assumes no responsibility for the functioning of undescribed features or parameters.

Trademarks

AMD and the AMD logo are registered trademarks of Advanced Micro Devices, Inc.

TAXIchip and TAXI are trademarks of Advanced Micro Devices, Inc.

Product names used in this publication are for identification purposes only and may be trademarks of their respective companies.

TABLE OF CONTENTS



Am7968/Am7969 TAXIchip Integrated Circuits	
Am7968/Am7969	Data Sheet 1
Am7968/Am7969	Technical Manual 50
Chapter 1	Introduction 50
	1.1 The Am7968 TAXI™ Transmitter 50
	1.2 The Am7969 TAXI Receiver 52
Chapter 2	Using the TAXIchip Set 52
	2.1 Data and Command 52
	2.2 Operational Modes: Local, Cascade and Test 53
Chapter 3	Data Encoding, Violation and Syncs 53
	3.1 Data Encoding 53
	3.2 Violation Logic 57
	3.3 TAXI PLL Characteristics 57
Chapter 4	Clock Generation and Distribution 59
	4.1 TAXI Transmitter Clock Connections 59
	4.1.1 Local Mode Transmitters 60
	4.2 TAXI Receiver Clock Connections 60
	4.2.1 Cascade Mode Receivers (Am7969-125 only) 61
Chapter 5	Interfacing with the Serial Media 61
	5.1 Very Short Link, DC Coupled 62
	5.2 Terminated, DC Coupled 63
	5.3 Terminated, AC Coupled 63
	5.4 Baseline Wander and the AC Coupling Capacitor 64
	5.5 Interfacing to Fiber Optic Transmitters/Receivers 66
	5.5.1 DC-Coupled TAXI-Fiber Optic Transceiver Interface 66
	5.5.2 AC-Coupled TAXI-Fiber Optic Transceiver Interface 68
	5.6 Interfacing to Coaxial Cable 68
	5.7 Interfacing to Twisted-Pair Cable 70
Chapter 6	Board Layout Considerations 71
	6.1 Printed Circuit Board Layout 71
	6.1.1 Rules for Layout 71
	6.2 Layout using Fiber Optic Data Links 73

Chapter 7	Cascade Mode Operation	74
	7.1 Transmit Cascaded Data with a Single TAXI Transmitter	76
	7.2 Receivers In Cascade Mode: Connections (Am7969-125 only)	79
	7.3 Auto-Repeat Configuration	81
	7.3.1 Receiver Connections in Auto-Repeat Configuration	81
	7.3.2 Timing Limitations of the Auto-Repeat Configuration	84
	7.4 Unbalanced Configuration (Am7968/Am7969-125 only)	85
Chapter 8	Test Mode	86
	8.1 Transmitter Connections	87
	8.2 Receiver Connections	89
	8.3 Timing Relationships in Test Mode	89
Appendix A	Optical Components Manufacturers	90
Appendix B	Error Detection Efficiency	91
Appendix C	TAXI TIPS	94



Am7968/Am7969

TAXIchip™ Integrated Circuits (Transparent Asynchronous Xmitter-Receiver Interface)

DISTINCTIVE CHARACTERISTICS

- **Parallel TTL bus interface**
 - Eight Data and four Command Pins
 - or nine Data and three Command Pins
 - or ten Data and two Command Pins
- **Transparent synchronous serial link**
 - +5 V ECL Serial I/O
 - AC or DC coupled
 - NRZI 4B/5B, 5B/6B encoding/decoding
- **Drive coaxial cable or twisted pair directly**
- **Easy interface with fiber optic data links**
- **32–140 Mbps (4–17.5 Mbyte/s) data throughput**
- **Asynchronous input using STRB/ACK**
- **Automatic MUX/DEMUX of Data and Command**
- **Complete on-chip PLL, Crystal Oscillator**
- **Single +5 V supply operation**
- **28-pin PLCC or DIP or LCC**

GENERAL DESCRIPTION

The Am7968 TAXIchip Transmitter and Am7969 TAXIchip Receiver Chipset is a general-purpose interface for very high-speed (4–17.5 Mbyte/s, 40–175 Mbaud serially) point-to-point communications over coaxial or fiber-optic media. The TAXIchip set emulates a pseudo-parallel register. They load data into one side and output it on the other, except in this case, the “other” side is separated by a long serial link.

The speed of a TAXIchip system is adjustable over a range of frequencies, with parallel bus transfer rates of 4 Mbyte/s at the low end, and up to 17.5 Mbyte/s at the high end. The flexible bus interface scheme of the TAXIchip set accepts bytes that are either 8, 9, or 10 bits wide. Byte transfers can be Data or Command signaling.

BLOCK DIAGRAM

Am7968

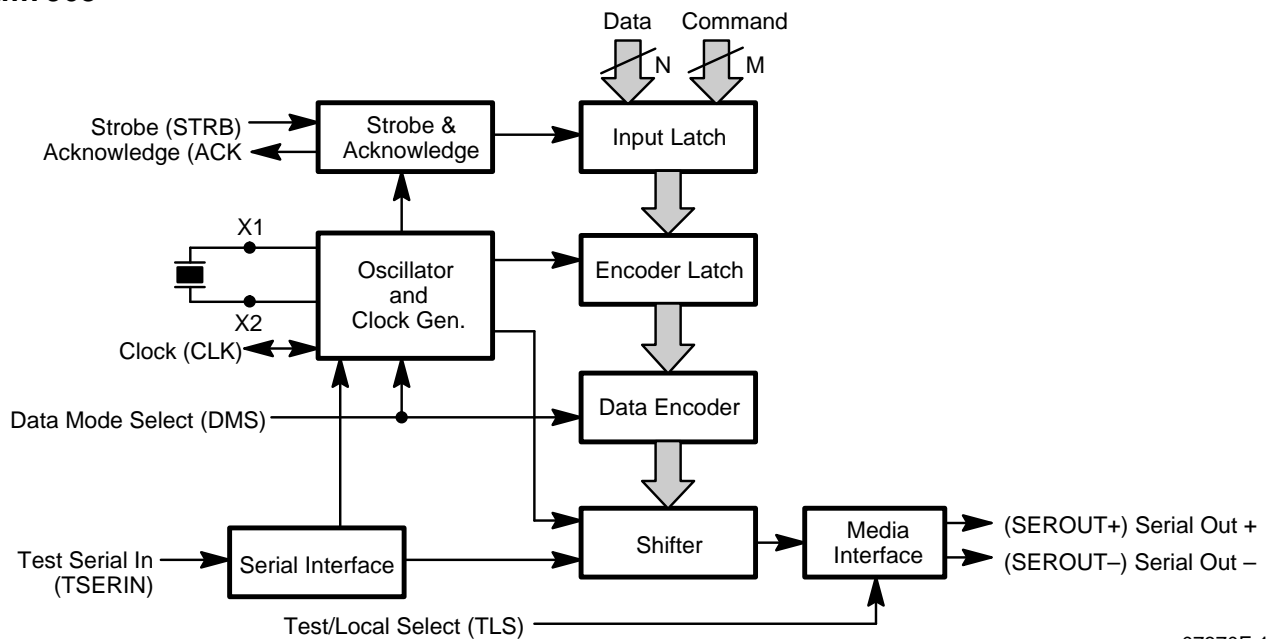

Note:

N can be 8, 9, or 10 bits; total of $N + M = 12$.

07370F-1

BLOCK DIAGRAM (continued)
Am7969

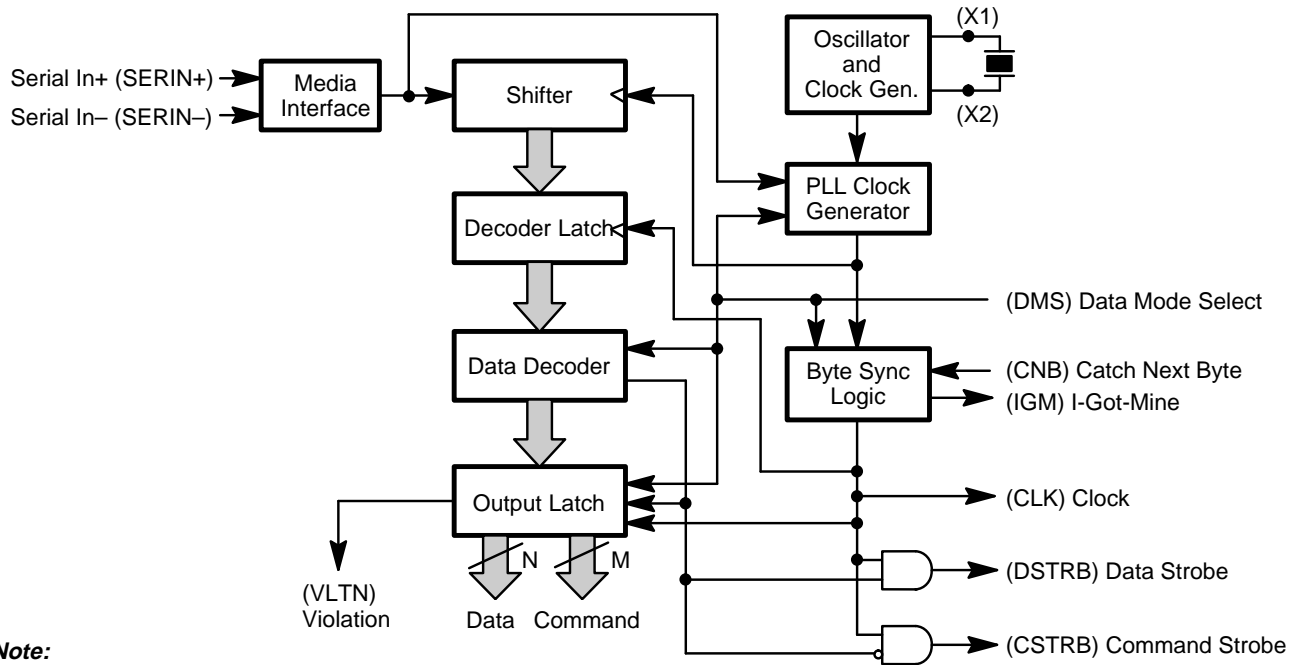

Note:

N can be 8, 9, or 10 bits Total of N + M = 12

07370F-2

CONNECTION DIAGRAMS

Top View
Am7968

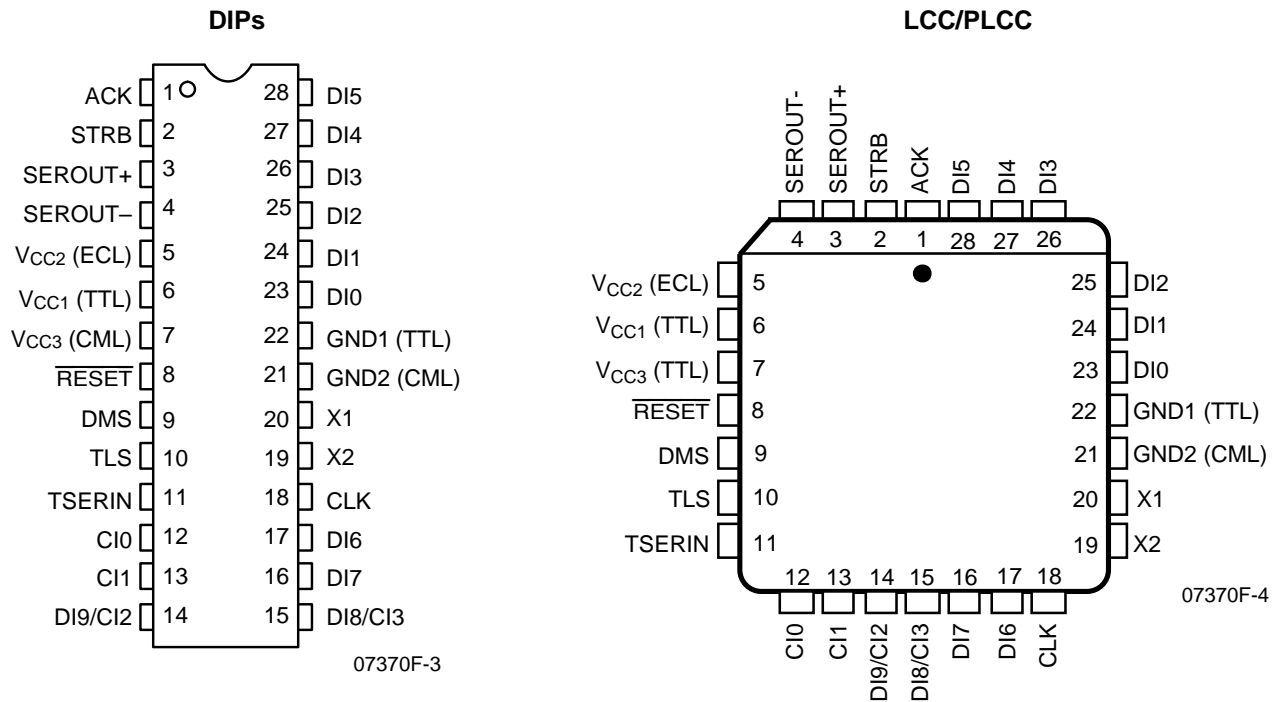

Note:

Pin 1 is marked for orientation.

07370F-4

CONNECTION DIAGRAMS (continued)

Top View Am7969

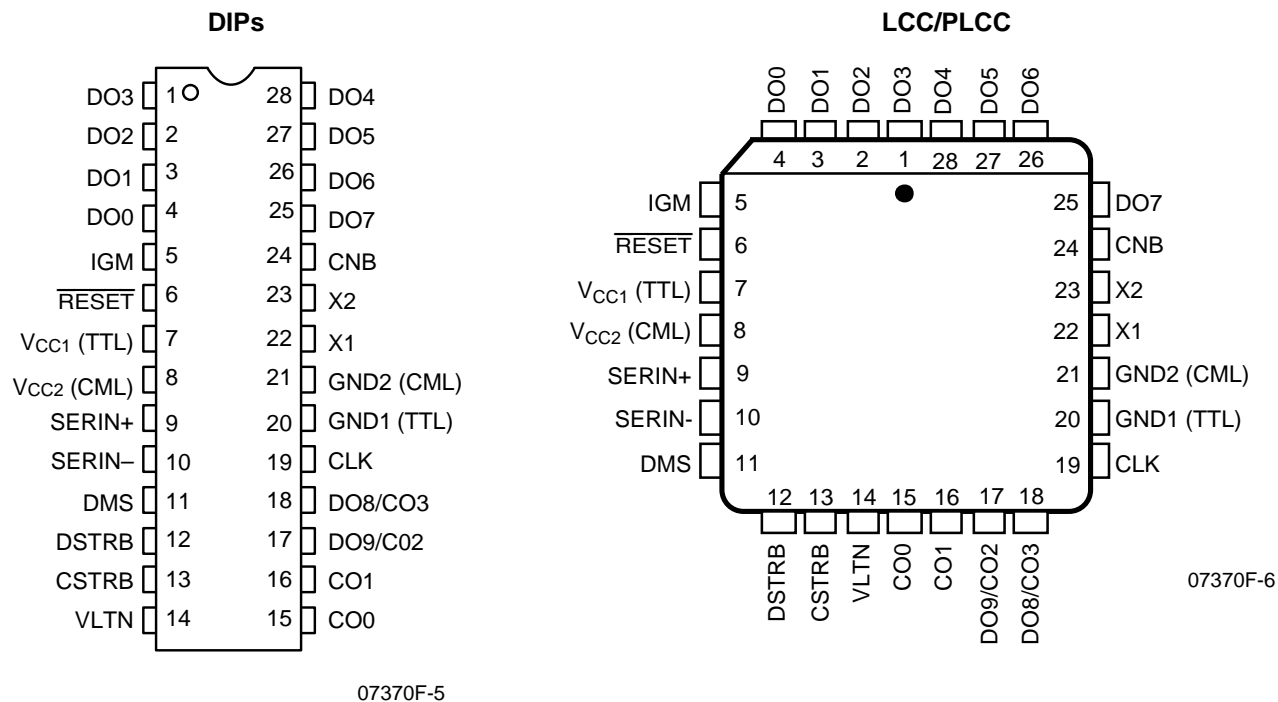

Note:

Pin 1 is marked for orientation.

LOGIC SYMBOLS

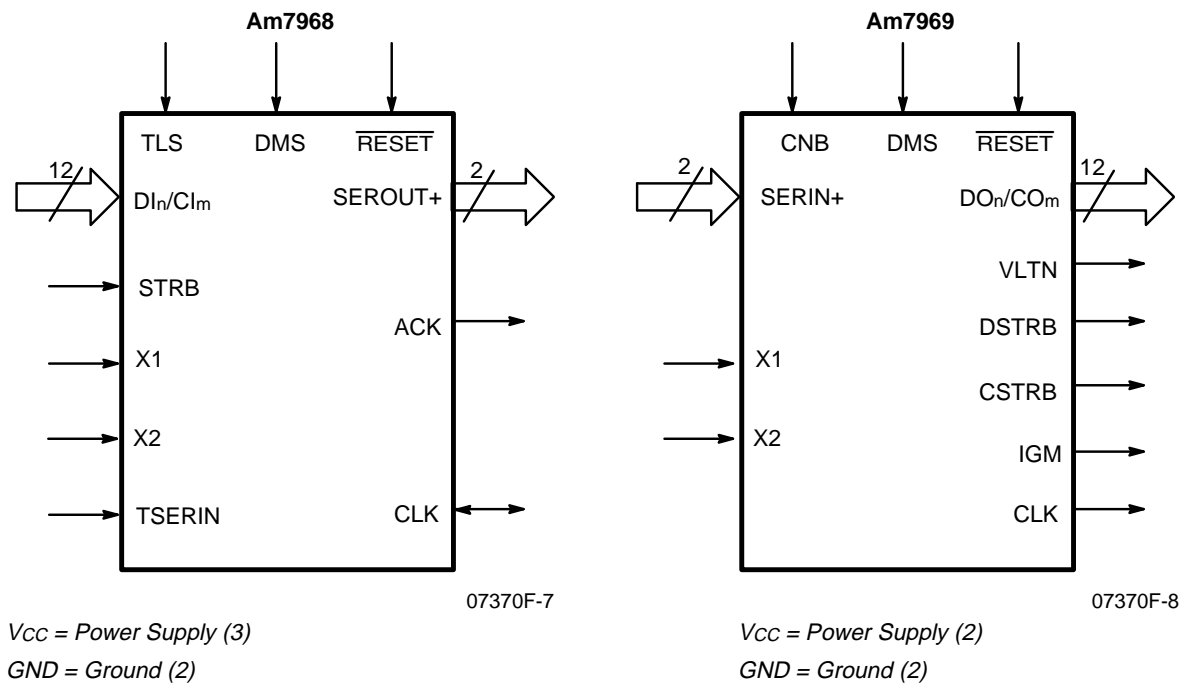

ORDERING INFORMATION

Standard Products

AMD standard products are available in several packages and operating ranges. The ordering number (Valid Combination) is formed by a combination of:

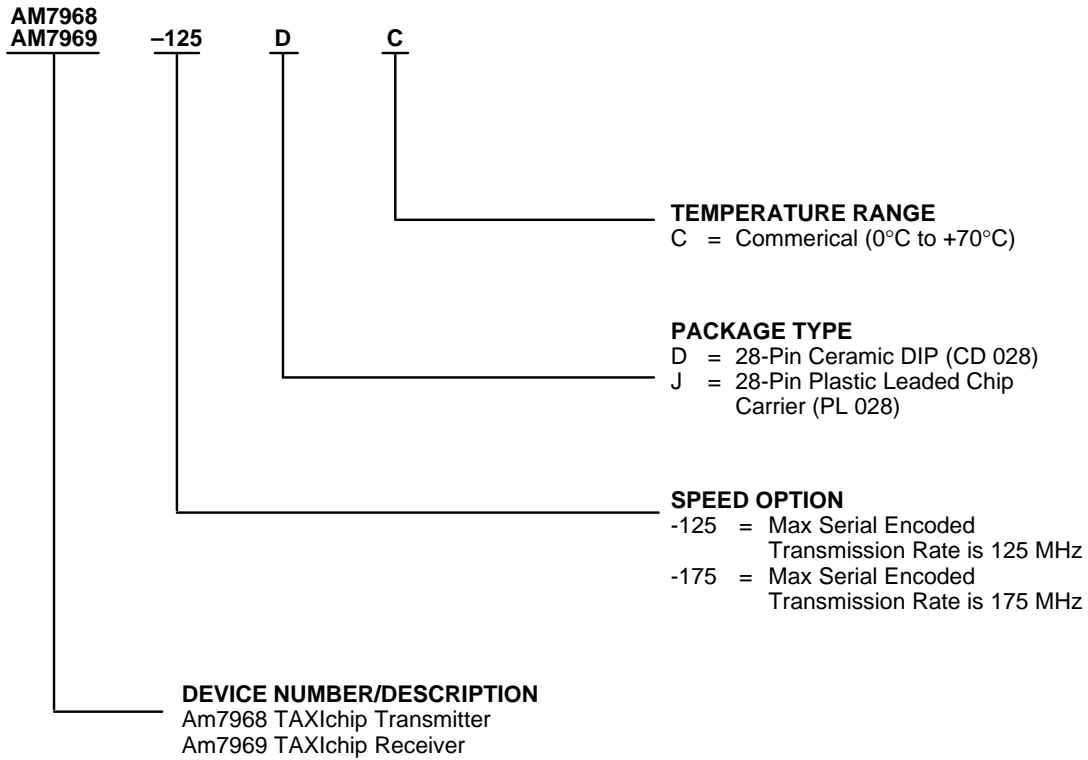

Valid Combinations	
AM7968-125	DC, JC
AM7969-125	
AM7968-175	
AM7969-175	

Valid Combinations

Valid Combinations list configurations planned to be supported in volume for this device. Consult the local AMD sales office to confirm availability of specific valid combinations and to check on newly released combinations.

MILITARY ORDERING INFORMATION

CPL Products

AMD products for Aerospace and Defense applications are available in several packages and operating ranges. CPL (Controlled Products List) products are compliant with MIL-STD-883C requirements with exceptions for V_{CC} or operating temperature. The order number (Valid Combination) is formed by a combination of:

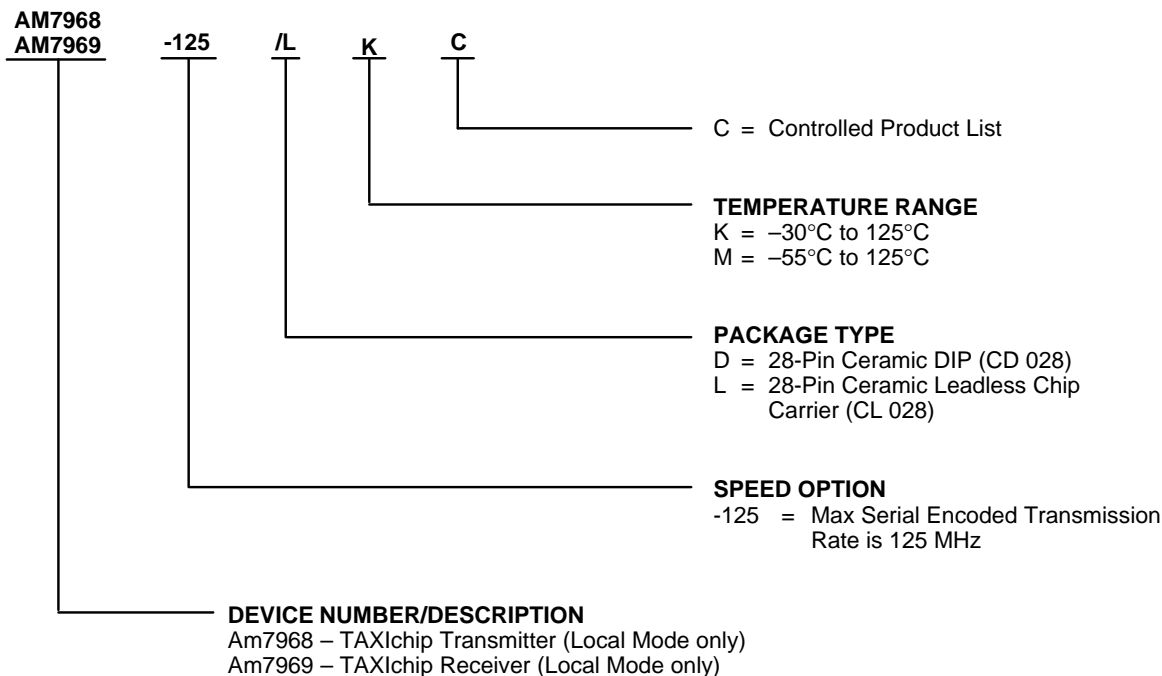

Valid Combinations

Valid Combinations list configurations planned to be supported in volume for this device. Consult the local AMD sales office to confirm availability of specific valid combinations and to check on newly released combinations.

Group A Tests

Group A tests consist of Subgroups 1, 2, 3, 7, 8, 9, 10, 11.

Valid Combinations

Pkg	Temps (TC)	V _{CC}	CPL Part Number	SMD Part Number	APL Part Number
LCC	-30°C to 125°C	4.5 V to 5.5 V	AM7968-125/LKC		
LCC	-55°C to 125°C	4.75 V to 5.5 V		5962-9052701M3A	AM7968-125V/B3A
DIP	-30°C to 125°C	4.5 V to 5.5 V	AM7968-125/DKC		
DIP	-55°C to 125°C	4.75 V to 5.5 V		5962-9052701MXA	AM7968-125V/BXA
LCC	-30°C to 125°C	4.5 V to 5.5 V	AM7969-125/LKC		
LCC	-55°C to 125°C	4.75 V to 5.5 V		5962-9052801M3A	AM7969-125V/B3A
DIP	-30°C to 125°C	4.5 V to 5.5 V	AM7969-125/DKC		
DIP	-55°C to 125°C	4.75 V to 5.5 V		5962-9052801MXA	AM7969-125V/BXA

PIN DESCRIPTION

Am7968 TAXIchip Transmitter

ACK

Input-Strobe Acknowledge (TTL Output)

ACK High signifies that the Am7968 is ready to accept new Data and Command. The timing of ACK's response to STRB depends on the condition of the Input Latch (in given CLK cycle).

If the Input Latch is empty, data is immediately stored and ACK closely follows STRB. If the Input Latch contains previously stored data when STRB is asserted, ACK is delayed until the next falling edge of CLK. Note that for ACK to rise STRB must maintain HIGH for both of the above conditions.

CI0 – CI1

Parallel Command In (TTL Inputs)

These two inputs accept parallel command information from the host system. If one or more command bits are logic "1", the command bit pattern is latched, encoded, and transmitted in place of any pattern on the Data inputs.

CLK

Clock (TTL I/O)

CLK is an I/O pin that supplies the byte-rate clock reference to drive all internal logic. When TLS is connected to ground (Local mode), CLK is enabled as a free-running (byte-rate) clock output which runs at the Crystal Oscillator frequency; this output can be used to drive the X1 input of TAXIchip Receivers or other system logic. In Test mode CLK becomes an input. In Test Mode 1 CLK is a Byte rate input and in Test Mode 2 it is a Bit rate input.

DI0 – DI7

Parallel Data In (TTL Inputs)

These eight inputs accept parallel data from the host system, to be latched, encoded and transmitted.

DI8/CI3

Parallel Data (8) In or Command (3) In (TTL Input)

DI8/CI3 input is either Data or Command, depending upon the state of DMS.

DI9/CI2

Parallel Data (9) In or Command (2) In (TTL Input)

DI9/CI2 input is either Data or Command, depending upon the state of DMS.

DMS

Data Mode Select (Input)

Data Mode Select input determines the Data pattern width. When it is wired to GND, the Am7968 Transmitter will assume Data to be eight bits wide, with four bits of

Command. When it is wired to VCC, the Am7968 Transmitter will assume Data to be nine bits wide, with three bits of Command. If DMS is left floating (or terminated to 1/2 VCC), the Am7968 will assume Data to be ten bits wide, with two bits of Command.

GND1, GND2

Ground Pins

GND1 is a TTL I/O Ground and GND2 is an internal Logic and Analog Ground.

RESET

PLL RESET (Input)

This pin is normally left open, but can be momentarily grounded to force the internal PLL to reactivate lock. This allows for correction in the unlikely occurrence of PLL lockup on application of power.

$\overline{\text{RESET}}$ has an internal pull-up resistor which causes it to float high when left unconnected (50 K ohm nominal).

If this board is driven by a board Reset signal, an open drain (or open collector) style output should be used to insure the High level signal is at V_{CC}.

SEROUT+, SEROUT–

Differential Serial Data Out (Differential Open Emitter ECL Outputs)

These differential ECL outputs generate data at ECL voltage levels referenced to +5.0 V. When connected to appropriated pull down resistors, they are capable of driving 50-Ω terminated lines, either directly or through isolating capacitors.

STRB

Input Strobe Signal (TTL Input)

A rising edge on the STRB input causes the Data (DI0 – DI9) or the Command (CI0 – CI3) inputs to be latched into the Am7968 Transmitter. The STRB signal is normally taken LOW after ACK has risen.

TLS

Test/Local Select (Input)

TLS input determines the mode of operation. When TLS is wired to GND, the Am7968 Transmitter assumes a Local mode connection to the media. It will output NRZI encoded data, and will enable its CLK output driver. The TLS pin should always be grounded during normal operation.

When TLS is wired to VCC (Test Mode 1), the serial data is NRZ, CLK becomes an input, and ACK timing is modified. This mode is only used for Automatic Test Equipment (ATE) testing at full speed.

When this input is left unconnected, it floats to an intermediate level which puts the Am7968 Transmitter into its Test Mode 2. In Test Mode 2, the internal clock

multiplier is switched out, and the internal logic is clocked directly from the CLK pin. Test Mode 2 is included to ease Automatic Test Equipment (A.T.E.) testing by making the internal logic of the Transmitter synchronous to the external clock instead of the internal PLL.

TSERIN

Test Serial Input (Pseudo ECL Input)

This pin is left unconnected in Local Mode operation. TSERIN can be used to input serial data patterns into the Shifter in Test Mode 1 operation.

V_{CC1}, V_{CC2}, V_{CC3}

Power Supply

V_{CC1}, V_{CC2}, and V_{CC3} are +5.0 volt nominal power supply pins. V_{CC1} powers TTL I/O, V_{CC2} powers ECL and V_{CC3} powers internal Logic and Analog circuitry.

X1, X2

Crystal Oscillator Inputs (Inputs)

The two crystal input pins connect to an internal parallel mode oscillator which operates at the fundamental frequency of the external crystal. The byte rate matches the crystal frequency. During normal operation, the byte rate is set by the crystal frequency.

Alternatively, X1 can be driven by an external TTL frequency source. In multiple TAXI systems this external source could be another Am7968's CLK output.

Am7969 TAXIchip Receiver

CLK

Clock (TTL Output)

This is a free-running clock output which runs at the byte rate, and is synchronous with the serial input. It falls at the time that the Decoder Latch is loaded from the Shifter, and rises at mid-byte. The *CLK* output of the Receiver is not suitable as a frequency source for another TAXI Transmitter or Receiver. It is intended to be used by the host system as a clock synchronous with the received data.

CNB

Catch Next Byte Input (TTL Input)

If this input is connected to the *CLK* output, the Receiver will be in the Local mode, and each received byte will be captured, decoded and latched to the outputs.

If the *CNB* input is HIGH, it allows the Am7969 Receiver to capture the first byte after a sync. The Am7969 Receiver will wait for another sync before latching the data out, and capturing another. If *CNB* is toggled LOW, it will react as if it had decoded a sync byte.

In Cascade mode, *CNB* input is typically connected to an upstream Am7969's *IGM* output. The first Am7969 Receiver in line will have its *CNB* input connected to V_{CC} .

For Am7969-175 applications, an inverter is required between CLK and CNB for speeds above 140 MHz. See Figure 3 and Timing Specifications T47A, T47B, T48, and T49.

CO0 – CO1

Parallel Command Out (TTL Output)

These two outputs reflect the most recent Command data received by the Am7969 Receiver.

CSTRB

Command Data Strobe (TTL Output)

The rising edge of this output signals the presence of new Command data on the CO0 – CO3 lines. Command bits are valid just before the rising edge of *CSTRB*.

DMS

Data Mode Select (Input)

DMS selects the Data pattern width. When it is wired to GND, the Am7969 Receiver will assume Data to be eight bits wide, with four bits of Command. When it is wired to V_{CC} the Am7969 Receiver will assume Data to be nine bits wide, with three bits of Command. If *DMS* is left floating (or terminated to $1/2 V_{CC}$), the Am7969 Receiver will assume Data to be ten bits wide, with two bits of Command.

DO0 – DO7

Parallel Data Out (TTL Outputs)

These eight outputs reflect the most recent Data received by the Am7969 Receiver.

DO8/CO3

Parallel Data (8) Out or Command (3) Out (TTL Output)

DO8/CO3 output will be either a Data or Command bit, depending upon the state of *DMS*.

DO9/CO2

Parallel Data (9) Out or Command (2) Out (TTL Output)

DO9/CO2 output will be either a Data or Command bit, depending upon the state of *DMS*.

DSTRB

Output Data Strobe (TTL Output)

The rising edge of this output signals the presence of new Data on the DO0 – DO9 lines. Data is valid just before the rising edge of *DSTRB*.

GND1, GND2

Ground

GND1 is a TTL I/O Ground, *GND2* is an internal Logic and Analog Ground.

IGM

I-Got-Mine (TTL Output)

This pin signals cascaded Am7969 Receivers that their upstream neighbor has captured its assigned data byte. *IGM* falls at the mid-byte when the first half of a sync byte is detected in the Shifter. It rises at mid-byte when it detects a non-sync pattern. During Local mode operation the *IGM* signal is undefined.

RESET

PLL RESET (Input)

This pin is normally left open, but can be momentarily grounded to force the internal PLL to reactivate lock. This allows for correction in the unlikely occurrence of PLL Lockup on application of power.

$\overline{\text{RESET}}$ has an internal pull-up resistor (50 K nominal) which causes it to float high when left unconnected.

If this board is driven by a board Reset signal, an open drain (or open collector) style output should be used to insure the High level signal is at V_{CC} .

SERIN+, SERIN–

Differential Serial Data In (ECL Inputs)

Data is shifted serially into the Shifter. The *SERIN+* and *SERIN–* differential ECL inputs accept ECL voltage

swings, which are referenced to +5.0 V. When *SERIN-* is grounded, the Am7969 is put into Test Mode; *SERIN+* becomes a single-ended ECL input, the PLL clock generator is bypassed, and *X1* determines the bit rate (rather than the byte rate). Both pins have internal pull down resistors which cause unterminated inputs to stay low.

V_{CC1}, V_{CC2} **Power Supply**

V_{CC1} and *V_{CC2}* are +5.0 volt nominal power supply pins. *V_{CC1}* powers TTL I/O, and *V_{CC2}* powers internal Logic and Analog circuitry.

VLTN **Violation (TTL Output)**

The rising edge of this output indicates that a transmission error has been detected. It changes state at the

same time *DOi* or *COi* change and will be followed by either *DSTRB* or *CSTRB*. This pin goes LOW when the next valid byte is decoded.

X1, X2 **Crystal Oscillator Inputs (Inputs)**

These two crystal input pins connect to an internal parallel/mode oscillator which oscillates at the fundamental frequency external crystal. During normal operation, the byte rate is set by the crystal frequency. Alternatively, *X1* can be driven by an external frequency source. In multiple TAXI systems, this external source could be a TAXI Transmitter's *CLK* output or an external TTL frequency source.

FUNCTIONAL DESCRIPTION

System Configuration

The TAXIchip system provides a means of connecting parallel data systems over a serial link (Figure 2). In LOCAL Mode (normal operation mode) each TX/RX pair is connected over a serial link which can be a Fiber Optic or Copper Media (Figure 3).

The Am7968 Transmitter accepts inputs from a sending host system using a simple *STRB/ACK* handshake. Parallel bits are saved by the Am7968's input latch on the rising edge of a *STRB* input. The input latch can be updated on every *CLK* cycle; if it still contains previously stored data when a second *STRB* pulse arrives, Data is stored in the input latch, and the second *ACK* response is delayed until the next *CLK* cycle.

The inputs to an Am7968 Transmitter can be either Data or Command and may originate from two different parts of the host system. A byte cycle may contain Data or Command, but not both. Data represents the normal data channel message traffic between host systems. Commands can come from a communication control section of the host system. Commands occur at a relatively infrequent rate but have priority over Data. Examples include communication specific commands such as REQUEST-TO-SEND or CLEAR-TO-SEND; or application specific commands such as MESSAGE-ADDRESS-FOLLOWS, MESSAGE-TYPE-FOLLOWS, INITIALIZE YOUR SYSTEM, ERROR, RETRANSMIT, HALT, etc.

The Am7968 Transmitter switches between Data and Command by examining Command input patterns. All 0s on Command input pins cause information on the Am7968's Data input pins to be latched into the device on the rising edge of *STRB*. All other Command patterns cause a Command symbol to be sent in response to an input strobe. The pattern on the Data inputs is ignored when a Command symbol is sent. In either case, if there is no *STRB* before the next byte boundary, a Sync symbol will be transmitted. The sync pattern maintains link synchronization and provides an adequate signal transition density to keep the Receiver Phase-Locked-Loop (PLL) circuits in lock. It was chosen for its unique pattern which never occurs in any Data or Command messages. This feature allows Sync to be used to establish byte boundaries.

The Sync pattern utilized by TAXIchip set keeps the automatic gain control (AGC) fiber-optic transceiver circuits in their normal range because the pattern has zero DC offset.

The Am7969 Receiver detects the difference between Data and Command patterns and routes each to the proper Output Latch. When a new Data pattern enters the output latch, *DSTRB* is pulsed and Command

information remains unchanged. If a Command pattern is sent to the output latch or if Sync is received, *CSTRB* is pulsed and Data outputs remain in their previous state. Reception of a Sync pattern clears the Command outputs to all 0's, since Sync is a legal command.

Noise-induced bit errors can distort transmitted bit patterns. The Am7969 Receiver logic detects most noise-induced transmission errors. Invalid bit patterns are recognized and indicated by the assertion of the violation (*VLTN*) output pin. This signal rises to a logic "1" state at the same time that Data or Command outputs change and remains HIGH until a valid pattern is detected by the Data Decoder. The error detection method used in the Receiver cannot identify bit errors which transform one valid Command or Data pattern to another. Fault-sensitive systems should use additional error checking mechanisms to guarantee message integrity.

Am7968 Transmitter

The Transmitter accepts messages from its parallel input pins (Command or Data). Once latched into an Am7968, a parallel message is encoded, serialized, and shifted out to the serial link. The idle time between transmitted bytes (evident by lack of *STRB*) is filled with Sync bytes.

Am7969 Receiver

Receivers accept differential signals on the *SERIN+/SERIN-* input pins. This information, previously encoded by an Am7968 Transmitter, is loaded into a decoder.

When serial patterns are received, they are decoded and routed to the appropriate outputs. If the received message is a Command, it is stored in the output latch, appears at the Command output pins, and *CSTRB* is pulsed; Data output pins continue holding the last Data byte and *DSTRB* stays inactive. If a Data message follows the reception of a Command, Command output pins continue holding the previous Command byte and *CSTRB* stays inactive. The command outputs will retain their states until another Command signal is received (Sync is considered to be a valid command which, when decoded, sets Command outputs to "0" and issues a resulting *CSTRB*).

Byte Width

The TAXIchip set has twelve parallel interface pins which are designated to carry either Command or Data bits. The Data Mode Select (*DMS*) pin on each chip can be set to select one of three modes of operation: eight Data and four Command bits, nine Data and three Command, or ten Data and two Command. This allows the system designer to select the byte-width which best suits system needs.

Am7968 Encoder/Am7969 Decoder

To guarantee that the Am7969's PLL can stay locked onto an incoming bit stream, the data encoding scheme must provide an adequate number of transitions in each data pattern. This implies a limit on the maximum time allowed between transitions. The TAXIchip set encoding scheme is based on the ANSI X3T9.5 (FDDI) committee's 4-bit/5-bit (4B/5B) code.

An ANSI X3T9.5 system used an 8-bit parallel data pattern. This pattern is divided into two 4-bit nibbles which are each encoded into a 5-bit symbol. Of the thirty-two patterns possible with these five bits, sixteen are chosen to represent the sixteen input Data patterns. Some of the others are used as Command symbols. Those remaining represent invalid patterns that fail either the run-length test or DC balance tests.

Transmitters in 8-bit mode use two 4B/5B encoders to encode eight Data bits into a 10-bit pattern. In 9-bit mode, Transmitters use one 5B/6B encoder and one 4B/5B encoder to code nine Data bits into an 11-bit pattern. In 10-bit mode, two 5B/6B encoders are used to change ten bits of Data into a 12-bit pattern (see Tables 1 and 2 for encoding patterns).

The Am7968 Transmitter further encodes all symbols using NRZI (Non Return to Zero, Invert on Ones). NRZI represents a "1" by a transition and a "0" by the lack of transition. In this system a "1" can be a HIGH-to-LOW or LOW-to-HIGH transition. This combination of 4B/5B and NRZI encoding ensures at least two transitions per symbol and permits a maximum of three consecutive non-transition bit times. The Am7969 then uses the same method to decode incoming symbols so that the whole encoding/decoding process is transparent to the user.

Most Serially transmitted data patterns with this code will have the same average amount of HIGH and LOW times. This near DC balance minimizes pattern-sensitive decoding errors which are caused by jitter in AC-coupled systems.

Operational Modes

In normal operational mode, a single Transmitter/Receiver pair is used to transfer 8, 9, or 10 bits of parallel Data over a private serial link. (On the Am7968, the *TLS* pin is tied to ground and *TSERIN* is left unconnected). On the Am7969, *CNB* must be connected to the *CLK* output. The Am7969 Receiver continuously deserializes the incoming bit stream, decodes the resulting patterns, and saves parallel data at its output latches (see Figure 3).

Local mode provides a fast and efficient parallel throughput because data can be transferred on every clock cycle. On the other hand, it is not necessary for the host to match the byte rate set by the Transmitter's crystal oscillator; the Am7968 automatically sends a Sync

pattern during each clock cycle in which no new Data or Command messages are being transmitted.

Cascade Mode (for -125 only)

For very wide parallel buses, TAXI Receiver's (commercial temperature parts only) can be Cascaded. The Am7969 Receivers all have their *SERIN+* and *SERIN-* pins connected to the media (or an optical data link). *IGM* of each Am7969 is connected to *CNB* of its downstream neighbor or is left unconnected on the Receiver farthest downstream. *CNB* of the first Receiver is tied HIGH, making this device the only Receiver in the chain that can act on the first non-Sync pattern in a message (see below).

Each TAXIchip Receiver monitors the serial link and a special acknowledgment scheme is used to direct symbols into each of the Am7969s. When a Catch-Next-Byte (*CNB*) input is HIGH, the Receiver will capture the next non-Sync symbol from the serial link. At this point, the device forces its I-Got-Mine (*IGM*) pin HIGH to tell the downstream Receiver to capture the next symbol. The Receiver then waits for the Sync symbol or for its *CNB* to be set LOW before transferring the message to its output latch. *IGM* is forced LOW whenever a Sync byte is detected or when *CNB* goes LOW. This *IGM-CNB* exchange continues down the chain until the last Receiver captures its respective byte. The next byte to appear on the serial link will be a Sync symbol which is detected by all of the cascaded Am7969s. On the following Clock cycle their messages are transferred to the output latch of each device and sent to the receiving host. *IGM* pins on all Receivers are also set LOW when the first half of the Sync symbol is detected.

Asynchronous Operation

Inputs to the Am7968 Transmitter Input Latch can be asynchronous to its internal clock. Data *STRB* will latch data into the Am7968 Transmitter and an internal clock will transfer the data to the Encoder Latch at the first byte boundary. Data can be entered at any rate less than the maximum transfer rate without regard to actual byte boundaries. As data rates approach the TAXI BYTE RATE, care must be taken to insure that the 2 BYTE FIFO inside TAXI Transmitter is not over filled. *STRB/ACK* handshake will assure that every byte is transferred correctly. At higher byte rates, where delays and setup/hold times make the *STRB/ACK* handshake impractical, *STRB* should be synchronized with *CLK*.

Synchronous Operation

The Transmitter may be strobed synchronous by tying the strobe to the input clock. When doing this a provision should be made to inhibit the strobe periodically to ensure proper byte alignment. In the absence of a strobe, Syncs will be transmitted on the serial link which will allow the receiver to re-align the byte boundaries. In addition it is essential that the delay between the falling edge

of the internal byte clock (CLK) and the rising edge of the strobe does not violate t_{BB} specification shown in the SWITCHING CHARACTERISTICS Section.

The internal byte clock controls the flow of data from the input register through the shift register. The falling edge of the internal byte clock delineates the end of one byte from the start of the next. Due to various tolerances in the PLL, the period of the internal byte clock may vary slightly. This effect may cause a shift in the location of the byte boundary with respect to the falling edge of the clock. This variation may move the byte boundary and therefore creates a window during which the part should not be strobed. This window called the t_6 window, is shown in the figure below. If the part is strobed during the t_6 window data will not be lost however, a sync may be added and the transmitter latency will be increased by one byte time.

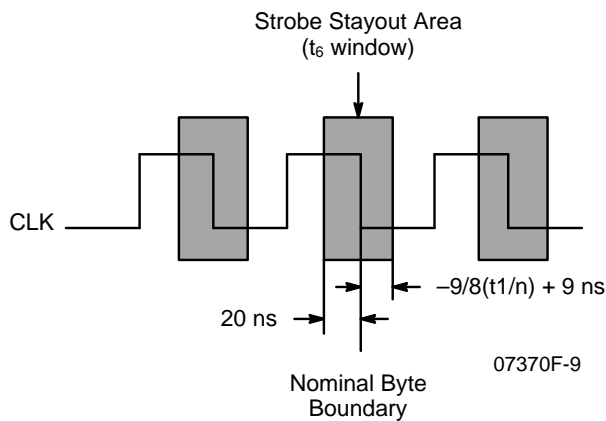

Sync Acquisition

In case of errors which cause Am7969 Receivers to lose byte/symbol sync, and on power-up, internal logic detects this loss-re-acquisition of sync and modifies the CLK output. CLK output is actually a buffered version of the signal which controls Data transfers inside the Am7969 Receiver on byte boundaries. Byte boundaries move when the Am7969 Receiver loses, and re-acquires sync. To protect slave systems (which may use this output as a clock synchronous with the incoming

data) from having clocks which are too narrow, the output logic will stretch an output pulse when the pulse would have been less than a byte-time long. The data being processed just prior to this re-acquisition of sync will be lost. The Sync symbol, and all subsequent data will be processed correctly.

TAXI User Test Modes

TLS input can be used to force the Am7968 Transmitter into either of the two Test modes. If TLS is open or terminated to approximately $V_{CC}/2$ (Test Mode 2), the internal VCO is switched out and everything is clocked directly from the CLK input. The serial output data rate will be at the CLK bit rate and not at 10X, 11X, or 12X, as is the case in normal operation. Test Mode 2 will allow testing of the logic in the Latches, Encoder, and Shifter without having to first stabilize the PLL clock multiplier. In Test Mode 1 (TLS wired to V_{CC}), the PLL is enabled and the chip operates normally, except that the output is an NRZ stream (CLK is an input & ACK function is slightly modified). This will allow testing of all functions at full rate without needing to perform match loop tests to accommodate the data inversion characteristics of NRZI.

Differential SERIN+/SERIN- inputs can be used to force the Am7969 Receiver into its Test mode. This will allow testing of the logic in the Latches, Decoder, and Shifter without having to first stabilize the the PLL. If SERIN- is tied to ground, the internal VCO is switched out and X_1 becomes the internal bit rate clock. The serial data rate will be at the CLK bit rate, not at 10X, 11X, or 12X, as is the case in normal operation. In this mode, SERIN+ becomes a single-ended serial data input with nominal 100K ECL threshold voltages (Referenced to +5 volts).

These Test Mode switches make the parts determinate, synchronous systems, instead of statistical, asynchronous ones. An automatic test system will be able to clock each part through the functional test patterns at any rate or sequence that is convenient. After the logic has been verified, the part can be put back into the normal mode, and the PLL functions verified knowing that the rest of the chip is functional.

Oscillator

The Am7968 and Am7969 contain an inverting amplifier intended to form the basis of a parallel mode oscillator. The design of this oscillator considered several factors related to its application.

The first consideration is the desired frequency accuracy. This may be subdivided into several areas. An oscillator is considered stable if it is insensitive to variations in temperature and supply voltage, and if it is unaffected by individual component changes and aging. The design of the TAXI chip set is such that the degree to which these goals are met is determined primarily by the choice of external components. Various types of crystal are available and the manufacturers' literature should be consulted to determine the appropriate type. For good temperature stability, zero temperature coefficient capacitors should be used (Type NPO).

The mechanism by which a crystal resonates is electro-mechanical. This resonance occurs at a fundamental

frequency (1st harmonic) and at all odd harmonics of this frequency (even harmonic resonance is not mechanically possible). Unless otherwise constrained, crystal oscillators operate at their fundamental frequencies.

A typical crystal specification for use in this circuit is:

Fundamental Frequency	3.3 MHz–17.5 MHz \pm 0.1%
Resonance: Mode	Parallel
Load Capacitor (Correlation)	30 pF
Operating Temperature Range	0°C to 70°C
Temperature Stability	\pm 100 ppm
Drive Level (Correlation)	2 mW
Effective Series Resistance	25 Ω (max)
Holder Type	Low profile
Aging for 10 years	\pm 10 ppm

It is good practice to ground the case of the crystal to eliminate stray pick-up and keep all connections as short as possible.

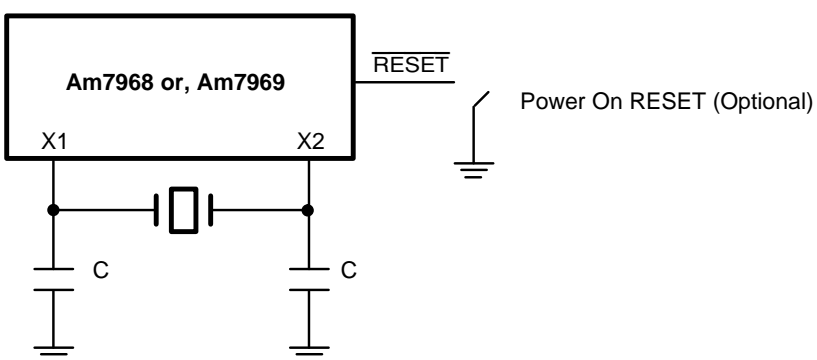

07370F-10

$C^* = 220$ pF for 4.0–12.5 MHz crystal, 150 pF for a 12.5–17.5 MHz Crystal.

*C determined by crystal specifications and trace capacities. Values shown are typical.

Figure 1. Connections for 4.0 MHz–17.5 MHz

Table 1. TAXIchip Encoder Patterns

4B/5B Encoder Scheme			5B/6B Encoder Scheme		
HEX Data	4-Bit Binary Data	5-Bit Encoded Symbol	HEX Data	5-Bit Binary Data*	6-Bit Encoded Symbol
0	0000	11110	00	00000	110110
1	0001	01001	01	00001	010001
2	0010	10100	02	00010	100100
3	0011	10101	03	00011	100101
4	0100	01010	04	00100	010010
5	0101	01011	05	00101	010011
6	0110	01110	06	00110	010110
7	0111	01111	07	00111	010111
8	1000	10010	08	01000	100010
9	1001	10011	09	01001	110001
A	1010	10110	0A	01010	110111
B	1011	10111	0B	01011	100111
C	1100	11010	0C	01100	110010
D	1101	11011	0D	01101	110011
E	1110	11100	0E	01110	110100
F	1111	11101	0F	01111	110101
			10	10000	111110
			11	10001	011001
			12	10010	101001
			13	10011	101101
			14	10100	011010
			15	10101	011011
			16	10110	011110
			17	10111	011111
			18	11000	101010
			19	11001	101011
			1A	11010	101110
			1B	11011	101111
			1C	11100	111010
			1D	11101	111011
			1E	11110	111100
			1F	11111	111101

*** Note:**

HEX data is parallel input data which is represented by the 4- or 5-bit binary data listed in the column to the immediate right of HEX data. Binary bits are listed from left to right in the following order.

8-Bit Mode: D7, D6, D5, D4, (4-Bit Binary), and D3, D2, D1, D0, (4-Bit Binary)

9-Bit Mode: D8, D7, D6, D5, D4, (5-Bit Binary), and D3, D2, D1, D0, (4-Bit Binary)

10-Bit Mode: D8, D7, D6, D5, D4, (5-Bit Binary), and D9, D3, D2, D1, D0, (5-Bit Binary)

Serial bits are shifted out with the most significant bit of the most significant nibble coming out first.

Table 2. TAXIchip Command Symbols

Am7968 Transmitter				Am7969 Receiver	
Command Input				Command Output	
HEX	Binary	Encoded Symbol	Mnemonic	HEX	Binary
8-Bit Mode					
0	0000	XXXXX XXXXX	Data	No Change (Note 2)	No Change (Note 2)
No STRB (Note 1)	No STRB (Note 1)	11000 10001	JK (8-bit Sync)	0	0000
1	0001	11111 11111	I I	1	0001
2	0010	01101 01101	TT	2	0010
3	0011	01101 11001	TS	3	0011
4	0100	11111 00100	I H	4	0100
5	0101	01101 00111	TR	5	0101
6	0110	11001 00111	SR	6	0110
7	0111	11001 11001	SS	7	0111
8 (Note 3)	1000	00100 00100	HH	8	1000
9	1001	00100 11111	HI	9	1001
A (Note 3)	1010	00100 00000	HQ	A	1010
B	1011	00111 00111	RR	B	1011
C	1100	00111 11001	RS	C	1100
D (Note 3)	1101	00000 00100	QH	D	1101
E (Note 3)	1110	00000 11111	Q I	E	1110
F (Note 3)	1111	00000 00000	QQ	F	1111
9-Bit Mode					
0	000	XXXXXX XXXXX	Data	No Change (Note 2)	No Change (Note 2)
No STRB (Note 1)	No STRB (Note 1)	011000 10001	LK (9-bit Sync)	0	000
1	001	111111 11111	I' I	1	001
2	010	011101 01101	T' T	2	010
3	011	011101 11001	T'S	3	011
4	100	111111 00100	I' H	4	100
5	101	011101 00111	T'R	5	101
6	110	111001 00111	S'R	6	110
7	111	111001 11001	S'S	7	111
10-Bit Mode					
0	00	XXXXXX XXXXXX	Data	No Change (Note 2)	No Change (Note 2)
No STRB (Note 1)	No STRB (Note 1)	011000 100011	LM (10-bit Sync)	0	00
1	01	111111 111111	I' I'	1	01
2	10	011101 011101	T' T'	2	10
3	11	011101 111001	T' S'	3	11

Notes:

1. Command pattern Sync cannot be explicitly sent by Am7968 Transmitter with any combination of inputs and STRB, but is used to pad between user data.
2. A strobe with all 0s on the Command input lines will cause Data to be sent. See Table 1.
3. While these Commands are legal data and will not disrupt normal operation if used occasionally, they may cause data errors if grouped into recurrent fields. Normal PLL operation cannot be guaranteed if one or more of these commands is continuously repeated.

Am7968 Transmitter Functional Block Description

(Refer to page 1)

Crystal Oscillator/Clock Generator

The serial link speed is derived from a master frequency source (byte rate). This source can either be the built-in Crystal Oscillator, or a clock signal applied through the *X1* pin. This signal is buffered and sent to the *CLK* output when Am7968 Transmitter is in Local mode.

CLK (input is multiplied by ten (8-bit mode), eleven (9-bit mode), or twelve (10-bit mode), using the internal PLL to create the bit rate.

The working frequency can be varied between 3.3 MHz and 17.5 MHz. The crystal frequency required to achieve the maximum 175 Mbaud on the serial link, and the resultant usable data transfer rate will be:

Mode	Crystal Frequency	Am7968-125 Input and Am7969-125 Maximum Parallel Throughput	Internal Divide Ratio
8-Bit	12.50 MHz	80 ns/pattern (100 Mbit/sec)	125/10
9-Bit	11.36 MHz	88 ns/pattern (102 Mbit/sec)	125/11
10-Bit	10.42 MHz	96 ns/pattern (104 Mbit/sec)	125/12
Mode	Crystal Frequency	Am7968-175 Input and Am7969-175 Maximum Parallel Throughput	Internal Divide Ratio
8-Bit	17.50 MHz	57.1 ns/pattern (140 Mbit/sec)	175/10
9-Bit	15.90 MHz	62.8 ns/pattern (143 Mbit/sec)	175/11
10-Bit	14.58 MHz	68.5 ns/pattern (145 Mbit/sec)	175/12

Input Latch

The Am7968's Input Latch accommodates asynchronous strobing of Data and Command by being divided into two stages.

If *STRB* is asserted when both stages are empty, Data or Command bits are transferred directly to the second stage of the Input Latch and *ACK* rises shortly after *STRB*. This pattern is now ready to move to the Encoder Latch at the next falling edge of *CLK*.

An input pattern is strobed into the first stage of the Input Latch only when the second stage is BUSY (contains previously stored data). The Transmitter will be BUSY when *STRB* is asserted a second time in a given *CLK* cycle. Contents of the first stage are not protected from subsequent *STRBs* within the same *CLK* cycle. At the falling edge of *CLK*, previously stored data is transferred from the second stage to the Encoder Latch and the new data is clocked into the second stage of the Input Latch. If in Local mode, *ACK* will rise at this time.

Encoder Latch

Input to the Encoder Latch is clocked by an internal signal which is synchronous with the shifted byte being sent on the serial link. Whenever a new input pattern is strobed into the Input Latch, the data is transferred to the Encoder Latch at the next opportunity.

Data Encoder

Encodes twelve data inputs (8, 9, 10 Data bits or 4, 3, 2 Command inputs) into 10, 11, or 12 bits. The Command data inputs control the transmitted symbol. If all Command inputs are LOW, the symbol for the Data bits will be sent. If Command inputs have any other pattern then the symbol representing that Command will be transmitted.

Shifter

The Shifter is parallel-loaded from the Encoder at the first available byte boundary, and then shifted until the next byte boundary. The Shifter is being serially loaded at all times. As data is being shifted out of the Transmitter, the shifter fills from the LSB. If parallel data is available at the end of the byte, it is parallel-loaded into the Shifter and begins shifting out during the next clock cycle. Otherwise, the serially loaded data fills the next byte. The serial data which loads into the Shifter is generated by an internal state machine which generates a repeating Sync pattern.

Media Interface

The Media Interface is differential ECL, referenced to +5 V. It is capable of driving lines terminated with 50 Ω to ($V_{cc} - 2.0$) volts.

Am7969 Receiver Functional Block Description

(Refer to page 1)

Crystal Oscillator/Clock Generator

The data recovery PLL in the Am7969 must be supplied with a reference frequency at the expected byte rate of the data to be recovered. The source of this frequency can either be the built-in Crystal Oscillator, or an external clock signal applied through the X_1 pin. The reference frequency source is then multiplied by ten (8-bit mode), eleven (9-bit mode) or twelve (10-bit mode) using an internal PLL.

Media Interface

SERIN+, SERIN– inputs are to be driven by differential ECL voltages, referenced to +5 V. Serial data at these inputs will serve as the reference for PLL tracking.

PLL Clock Generator

A PLL Clock recovery loop follows the incoming data and allows the encoded clock and data stream to be decoded into a separated clock and data pattern. It uses the crystal oscillator and clock generator to predict the expected frequency of data and will track jittered data with a characteristically small offset frequency.

Shifter

The Shifter is serially loaded from the Media Interface, using the bit clock generated by PLL.

Byte Sync Logic

The incoming data stream is a continuous stream of data bits, without any significant signal which denotes byte boundaries. This logic will continuously monitor the data stream, and upon discovering the reserved code used for Am7969 Receiver Sync, will initialize a synchronous counter which counts bits, and indicates byte boundaries.

The logic signal that times data transfers from the Shifter to the Decoder Latch is buffered and sent to the CLK output. CLK output from the Receiver is not suitable as a frequency source for another TAXI Transmitter or Receiver. It is intended to be used by the host system as a clock synchronous with the received data. This output is synchronous with the byte boundary and is synchronous with the Receiver's internal byte clock.

Byte Sync Logic is responsible for generating the internal strobe signals for Parallel Output Latches. It also generates the IGM (I-Got-Mine) signal in Test mode

when the first byte after a Sync symbol is transferred. Parallel outputs are made on a byte boundary, after CNB falls, or when Sync is detected.

The I-Got-Mine (IGM) signal will fall when the first half of a Sync is detected in the Shifter or when CNB goes LOW. It will remain LOW until the first half of a non-Sync byte is detected in the Shifter, whereupon it will rise (assuming that the CNB input is HIGH). A continuous stream of normal data or command bytes will cause IGM to go HIGH and remain HIGH. A continuous stream of Sync's will cause IGM to stay LOW. IGM will go HIGH during the byte before data appears at the output. This feature could be used to generate an early warning of incoming data.

Decoder Latch

Data is loaded from the Shifter to this latch at each symbol/byte boundary. It serves as the input to the Data Decoder.

Data Decoder

Decodes ten, eleven, or twelve data inputs into twelve outputs. In 8-bit mode, data is decoded into either an 8-bit Data pattern or a 4-bit Command pattern. In 9-bit mode, data is decoded into either a 9-bit Data pattern or a 3-bit Command pattern. In 10-bit mode, data is decoded into either a 10-bit Data pattern or a 2-bit Command pattern.

The decoder separates Data symbols from Command symbols, and causes the appropriate strobe output to be asserted.

Parallel Output Latch

Output Latch will be clocked by the byte clock, and will reflect the most recent data on the link. Any Data pattern will be latched to the Data outputs and will not affect the status of the Command outputs. Likewise, any Command pattern will be latched to the Command outputs without affecting the state of the Data outputs.

Any data transfer, either Data or Command will be synchronous with an appropriate output strobe. However, there will be $CSTRBs$ when there is no active data on the link, since Sync is a valid Command code.

Any pattern which does not decode to a valid Command or Data pattern is flagged as a violation. The output of the decoder during these violations is indeterminate and will result in either a $CSTRB$ or $DSTRB$ output when the indeterminate pattern is transferred to the output latch.

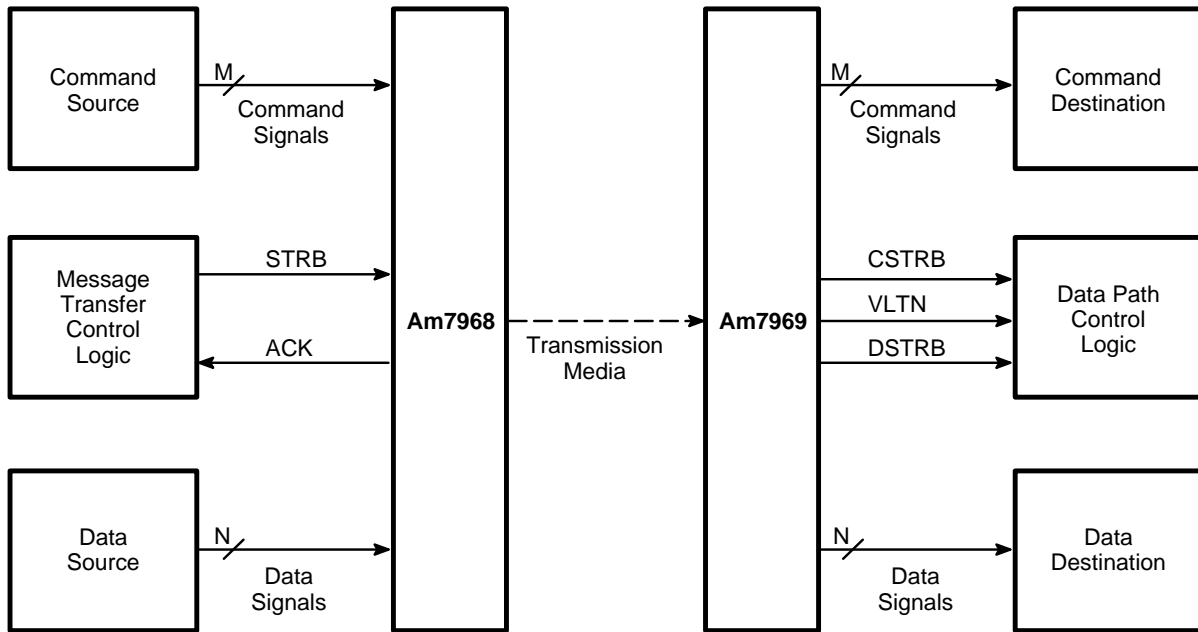

07370F-11

Note:

N can be 8, 9, or 10 bits of parallel data; total of $N + M = 12$.

Figure 2. TAXIchip System Block Diagram

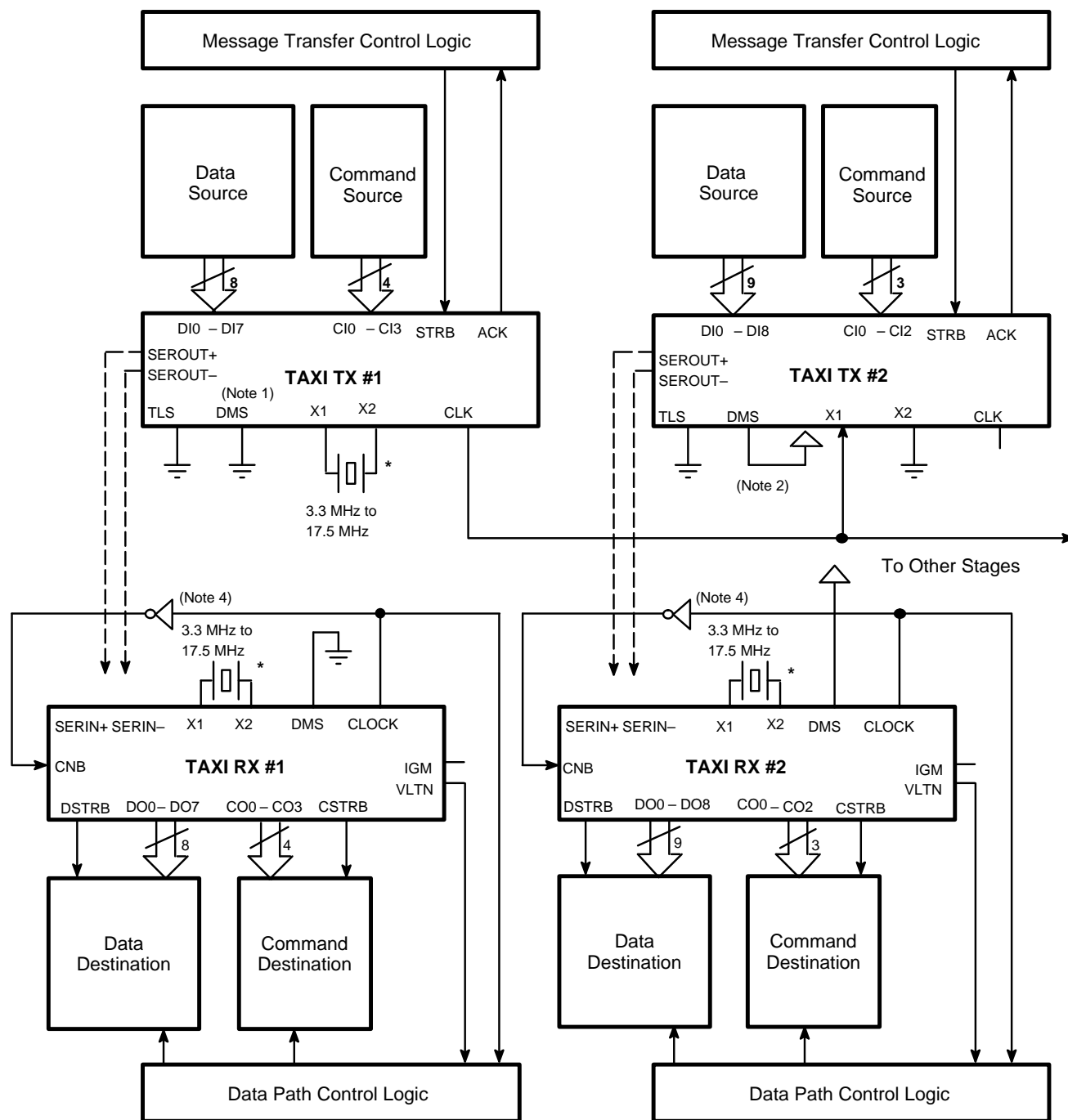

07370F-12

Notes:

- 1. DMS = GND = 8 Bit Mode TLS = GND = Local Mode Pin 11 = Don't Connect = Local Mode
 - 2. DMS = Vcc = 9 Bit Mode TLS = GND = Local Mode Pin 11 = Don't Connect = Local Mode
 - 3. Two 8-bit local mode systems in parallel will result in an effective data rate of 200 Mbps.
 - 4. Use inverter for operation above 140 MHz only.
- *Alternatively, the X1 inputs may be driven by external TTL frequency sources.

Figure 3. TAXIchip System in Local Mode

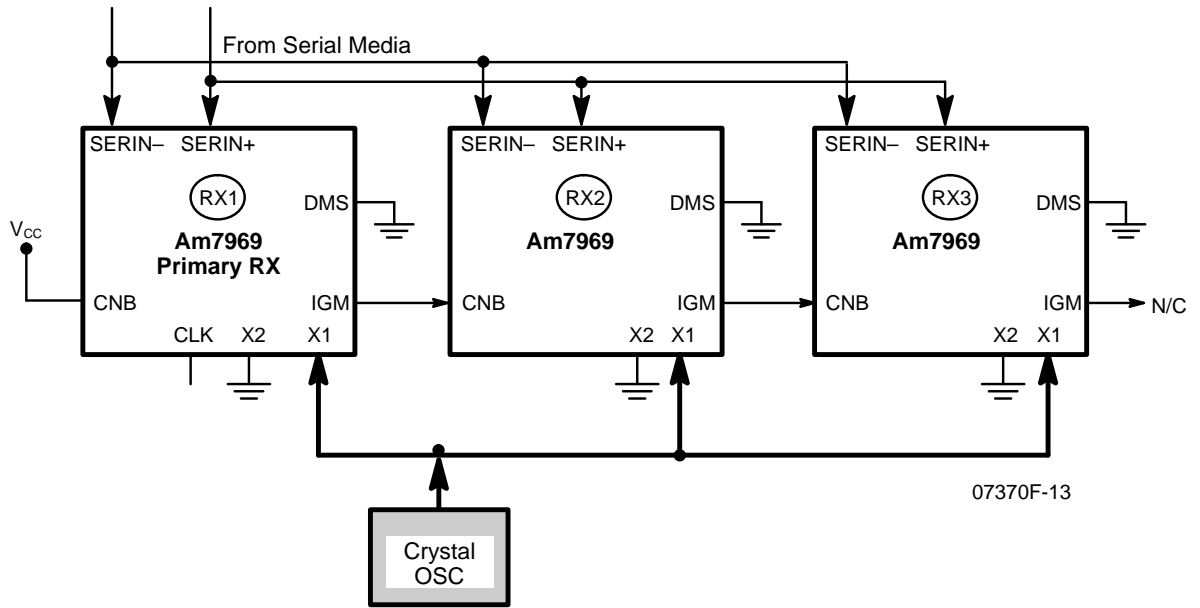

Figure 4. Cascaded Receiver Clock Connections (Commercial -125 only)

Am7968/Am7969-125**ABSOLUTE MAXIMUM RATINGS**

Storage Temperature	-65°C to +150°C
Ambient Temperature Under Bias	-55°C to +125°C
Supply Voltage to Ground Potential Continuous	-0.5 V to +7.0 V
DC Voltage Applied to Outputs	-0.5 V to V _{CC} Max
DC Input Voltage	-0.5 V to +5.5 V
DC Output Current	±100 mA
DC Input Current	-30 mA to +5.0 mA

Stresses above those listed under Absolute Maximum Ratings may cause permanent device failure. Functionality at or above these limits is not implied. Exposure to absolute maximum ratings for extended periods may affect device reliability.

OPERATING RANGES**Commercial (C) Devices**

Temperature (T _A)	0°C to +70°C
Supply Voltage (V _{CC})	+4.5 V to +5.5 V

Operating ranges define those limits between which the functionality of the device is guaranteed.

DC CHARACTERISTICS over operating range unless otherwise specified
Am7968-125 TAXIchip Transmitter

Parameter Symbol	Parameter Description	Test Conditions (Note 1)	Min	Max	Unit	
Bus Interface Signals: DI0–DI7, DI8/CI3, DI9/CI2, CI0–CI1, STRB, ACK, CLK						
V _{OH1}	Output HIGH Voltage ACK	V _{CC} = Min, I _{OH} = –1 mA V _{IN} = 0 or 3 V	2.4		V	
V _{OH2}	Output HIGH Voltage CLK	V _{CC} = Min, I _{OH} = –3 mA V _{IN} = 0 or 3 V	2.4		V	
V _{OL}	Output LOW Voltage ACK, CLK	V _{CC} = Min, I _{OL} = 8 mA V _{IN} = 0 or 3 V		0.45	V	
V _{IH}	Input HIGH Voltage	V _{CC} = Max (Note 9)	2.0		V	
V _{IL}	Input LOW Voltage	V _{CC} = Max (Note 9)		0.8	V	
V _I	Input Clamp Voltage	V _{CC} = Min I _{IN} = –18 mA		–1.5	V	
I _{IL}	Input LOW Current	V _{CC} = Max, V _{IN} = 0.4 V		–400	μA	
I _{IH}	Input HIGH Current	V _{CC} = Max, V _{IN} = 2.7 V		50	μA	
I _I	Input Leakage Current	V _{CC} = Max, V _{IN} = 5.5 V	All Inputs Except CLK		50	μA
			CLK Input		150	μA
I _{SC}	Output Short Circuit Current ACK, CLK	(Note 4)	–15	–85	mA	
Serial Interface Signals: SEROUT+, SEROUT–						
V _{OH}	Output HIGH Voltage	V _{CC} = Min ECL Load	V _{CC} –1.025	V _{CC} –0.88	V	
V _{OL}	Output LOW Voltage	V _{CC} = Min ECL Load	V _{CC} –1.81	V _{CC} –1.62	V	
Miscellaneous Signals: X1, V_{CC1}, V_{CC2}, V_{CC3}						
V _{IHX}	Input HIGH Voltage X1		2.0		V	
V _{ILX}	Input LOW Voltage X1			0.8	V	
I _{ILX}	Input LOW Current X1	V _{IN} = 0.45 V		–900	μA	
I _{IHX}	Input HIGH Current X1	V _{IN} = 2.4 V		+600	μA	
I _{CC}	Supply Current	SEROUT = ECL Load, DMS = 0 V _{CC1} = V _{CC2} = V _{CC3} = Max	Pin V _{CC1} (TTL)		20	mA
			Pin V _{CC2} (ECL)		45	mA
			Pin V _{CC3} (CML)		200	mA

*See notes following end of Switching Characteristics tables.

Am7969-125 TAXIchip Receiver

Parameter Symbol	Parameter Description	Test Conditions (Note 1)	Min	Max	Unit
Bus Interface Signals: DO0–DO7, DO8/CO3, DO9/CO2, CO0–CO1, DSTRB, CSTRB, IGM, CLK, CNB, VLTN					
V _{OH}	Output HIGH Voltage	V _{CC} = Min, I _{OH} = –1 mA V _{IN} = 0 or 3 V	2.4		V
V _{OL}	Output LOW Voltage	V _{CC} = Min, I _{OL} = 8 mA V _{IN} = 0 or 3 V		0.45	V
V _{IH}	Input HIGH Voltage	V _{CC} = Max (Note 9)	2.0		V
V _{IL}	Input LOW Voltage	V _{CC} = Max (Note 9)		0.8	V
V _I	Input Clamp Voltage	V _{CC} = Min, I _{IN} = –18 mA		–1.5	V
I _{IL}	Input LOW Current	V _{CC} = Max, V _{IN} = 0.4 V		–400	μA
I _{IH}	Input HIGH Current	V _{CC} = Max, V _{IN} = 2.7 V		50	μA
I _I	Input Leakage Current	V _{CC} = Max, V _{IN} = 5.5 V		50	μA
I _{SC}	Output Short Circuit Current (Note 4)		–15	–85	mA
Serial Interface Signals: SERIN+, SERIN–					
V _{IHS}	Input HIGH Voltage SERIN+	(Notes 9, 21)	V _{CC} –1.165	V _{CC} –0.88	V
V _{ILS}	Input LOW Voltage SERIN+	(Notes 9, 21)	V _{CC} –1.81	V _{CC} –1.475	V
V _{THT}	Test Mode Threshold SERIN–	V _{CC} = Max		0.25	V
V _{DIF}	Differential Input Voltage		0.3	1.1	V
V _{ICM}	Input Common Mode Voltage	(Note 6)	3.05	V _{CC} –0.55	V
I _{IL}	Input LOW Current	V _{CC} = Max, V _{IN} = V _{CC} – 1.81 V	0.5		μA
I _{IH}	Input HIGH Current	V _{CC} = Max, V _{IN} = V _{CC} – 0.88 V		220	μA
Miscellaneous Signals: X1, V_{CC1}, V_{CC2}					
V _{IHX}	Input HIGH Threshold X1		2.0		V
V _{ILX}	Input LOW Threshold X1			0.8	V
I _{ILX}	Input LOW Current X1	V _{IN} = 0.45 V		–900	μA
I _{IHX}	Input HIGH Current X1	V _{IN} = 2.4 V		+600	μA
I _{CC}	Supply Current	V _{CC1} = V _{CC2} = Max	Pin V _{CC1} (TTL)	50	mA
		DMS = 0 V	Pin V _{CC2} (CML)	300	mA

SWITCHING CHARACTERISTICS (Note 20)
Am7968-125 TAXIchip Transmitter (Notes 10, 13, 22)

No.	Parameter Symbol	Parameter Description	Test Conditions	Min	Max	Units
Bus Interface Signals: DI0–DI7, DI8/CI3, DI9/CI2, CI0–CI1, STRB, ACK, CLK						
1	tp	CLK Period		8n	25n	ns
2	tpW	CLK Pulse Width HIGH		30		ns
3	tpW	CLK Pulse Width LOW		30		ns
4	tpW	STRB Pulse Width HIGH (Note 7)		15		ns
5	tpW	STRB Pulse Width LOW		15		ns
6	tBB	Internal Byte Boundary to CLK↓ (Note 11)		$\frac{-9t_1}{8n} + 9$	20	ns
9	ts	Data–STRB Setup Time		5		ns
10	tH	Data–STRB Hold Time		15		ns
11	tH	ACK↑ to STRB↓ Hold (Note 8)	TTL Output Load	0		ns
12	tH	ACK↓ to STRB↑ Hold	TTL Output Load	0		ns
13	tpD	STRB↑ to ACK↑ (Note 18)	TTL Output Load		40	ns
14	tpD	STRB↓ to ACK↓	TTL Output Load		23	ns
15	tpD	CLK↓ to ACK↑ (Note 18)	TTL Output Load		$\frac{3t_1}{n} + 33$	ns
Serial Interface Signals: SEROUT+, SEROUT– (Note 2)						
22	tSK [†]	SEROUT± Skew	ECL Output Load	–200	+200	ps
23	tR [†]	SEROUT± Output Rise Time	ECL Output Load	.45	2	ns
24	tF [†]	SEROUT± Output Fall Time	ECL Output Load	.45	2	ns
26	tpW [†]	SEROUT ± Pulse Width LOW	ECL Output Load	$\frac{t_1}{n} - 5\%$	$\frac{t_1}{n} + 5\%$	ns
27	tpW [†]	SEROUT ± Pulse Width HIGH	ECL Output Load	$\frac{t_1}{n} - 5\%$	$\frac{t_1}{n} + 5\%$	ns
Miscellaneous Signals: X1 (Note 15)						
29	tpW	X1 Pulse Width HIGH (Note 12)	TTL Output Load on CLK	35		ns
30	tpW	X1 Pulse Width LOW (Note 12)	TTL Output Load on CLK	35		ns
32	tpD	X1 ↑ to CLK↑	TTL Load		32	ns
33	tpD	X1 ↓ to CLK↓	TTL Load		32	ns

Am7969-125 TAXIchip Receiver (Notes 13, 14, 22)

No.	Parameter Symbol	Parameter Description	Test Conditions	Min	Max	Unit
Bus Interface Signals: DO0–DO7, DO8/CO3, DO9/CO2, CO0–CO1, DSTRB, CSTRB, IGM, CLK, CNB, VLTN						
35	tp	CLK Period (Note 24)		8n	25n	ns
36	tpD	Data Valid to STRB↑ Delay	TTL Output Load	$\frac{2t_{35}}{n}$		ns
37	tpD	CLK↓ to STRB↑	TTL Output Load		$\frac{2t_{35}}{n} + 15$	ns
38	tpD	CLK↑ to STRB↓	TTL Output Load	$\frac{t_{35}}{n} - 7$		ns
38a	tpD	STRB↑ to CLK↑ (Note 23)	TTL Output Load	$\frac{3t_{35}}{n} - 14$		ns
39	tpD	CLK↓ to Data Valid Delay	TTL Output Load		$-\left(\frac{t_{35}}{n}\right) + 23$	ns
40	tpW	STRB Pulse Width HIGH	TTL Output Load	$\frac{5t_{35}}{2n}$	$\frac{5t_{35}}{n}$	ns
41	tpW	CLK Pulse Width HIGH	TTL Output Load	$\frac{5t_{35}}{n} - 15$		ns
42	tpW	CLK Pulse Width LOW	TTL Output Load	$\frac{5t_{35}}{n} - 15$		ns
43	tpD	SERIN to CLK↓ Delay	TTL Output Load	$\frac{t_{35}}{2n} + 17$	$\frac{2t_{35}}{n} + 26$	ns
44	tpD	CLK↑ to IGM↓	TTL Output Load		$\frac{2t_{35}}{n} + 7$	ns
45	tpD	CLK↑ to IGM↑	TTL Output Load		$\frac{2t_{35}}{n} + 10$	ns
46	tpD	CNB↓ to IGM↓	TTL Output Load		20	ns
47	ts	CNB↑ to CLK↑ Setup Time (Note 5)		$-\left(\frac{2t_{35}}{n} - 32\right)$		ns
47A	ts	CNB↓ to CLK↑ Setup Time (Note 19)		$-\left(\frac{t_{35}}{n} - 31\right)$		ns
48	tH	CNB↓ to CLK↑ Hold		$\frac{2t_{35}}{n} + 5$		ns
49	tpW	CNB Pulse Width LOW		$\frac{2t_{35}}{n}$		ns
Serial Interface Signals: SERIN+, SERIN–						
57	t _J [†]	SERIN± Peak to Peak Input Jitter Tolerance (Note 16)			5	ns
Miscellaneous Signals: X1 (Note 15)						
60	tpW	X1 Pulse Width HIGH		35		ns
61	tpW	X1 Pulse Width LOW		35		ns

(Page intentionally left blank)

Am7968/Am7969-175**ABSOLUTE MAXIMUM RATINGS**

Storage Temperature	-65°C to + 50°C
Ambient Temperature Under Bias	-55°C to +125°C
Supply Voltage to Ground Potential Continuous	-0.5 V to +7.0 V
DC Voltage Applied to Outputs	-0.5 V to V _{CC} Max
DC Input Voltage	-0.5 V to +5.5 V
DC Output Current	+100 mA
DC Input Current	-30 mA to +5.0 mA

Stresses above those listed under Absolute Maximum Ratings may cause permanent device failure. Functionality at or above these limits is not implied. Exposure to absolute maximum ratings for extended periods may affect device reliability.

OPERATING RANGES**Commercial (C) Devices**

Temperature (T _c)	0°C to +70°C
Supply Voltage (V _{CC})	+4.5 V to +5.5 V

Operating ranges define those limits between which the functionality of the device is guaranteed.

DC CHARACTERISTICS over operating range unless otherwise specified
Am7968-175 TAXIchip Transmitter

Parameter Symbol	Parameter Description	Test Conditions (Note 1)	Min	Max	Unit	
Bus Interface Signals: DI0–DI7, DI8/CI3, DI9/CI2, CI0–CI1, STRB, ACK, CLK						
V _{OH1}	Output HIGH Voltage ACK	V _{CC} = Min, I _{OH} = –1 mA V _{IN} = 0 or 3 V	2.4		V	
V _{OH2}	Output HIGH Voltage CLK	V _{CC} = Min, I _{OH} = –3 mA V _{IN} = 0 or 3 V	2.4		V	
V _{OL}	Output LOW Voltage ACK, CLK	V _{CC} = Min, I _{OL} = 8 mA V _{IN} = 0 or 3 V		0.45	V	
V _{IH}	Input HIGH Voltage	V _{CC} = Max (Note 9)	2.0		V	
V _{IL}	Input LOW Voltage	V _{CC} = Max (Note 9)		0.8	V	
V _I	Input Clamp Voltage	V _{CC} = Min I _{IN} = –18 mA		–1.5	V	
I _{IL}	Input LOW Current	V _{CC} = Max, V _{IN} = 0.4 V		–400	μA	
I _{IH}	Input HIGH Current	V _{CC} = Max, V _{IN} = 2.7 V		50	μA	
I _I	Input Leakage Current	V _{CC} = Max, V _{IN} = 5.5 V	All Inputs Except CLK		50	μA
			CLK Input		150	μA
I _{SC}	Output Short Circuit Current ACK, CLK	(Note 4)	–15	–85	mA	
Serial Interface Signals: SEROUT+, SEROUT–						
V _{OH}	Output HIGH Voltage	V _{CC} = Min ECL Load	V _{CC} –1.025	V _{CC} –0.88	V	
V _{OL}	Output LOW Voltage	V _{CC} = Min ECL Load	V _{CC} –1.81	V _{CC} –1.62	V	
Miscellaneous Signals: X1, V_{CC1}, V_{CC2}, V_{CC3}						
V _{IHX}	Input HIGH Voltage X1		2.0		V	
V _{ILX}	Input LOW Voltage X1			0.8	V	
I _{ILX}	Input LOW Current X1	V _{IN} = 0.45 V		–900	μA	
I _{IHX}	Input HIGH Current X1	V _{IN} = 2.4 V		+600	μA	
I _{CC}	Supply Current	SEROUT = ECL Load, DMS = 0 V _{CC1} = V _{CC2} = V _{CC3} = Max	Pin V _{CC1} (TTL)		20	mA
			Pin V _{CC2} (ECL)		45	mA
			Pin V _{CC3} (CML)		200	mA

*See notes following end of Switching Characteristics tables.

Am7969-175 TAXIchip Receiver

Parameter Symbol	Parameter Description	Test Conditions (Note 1)	Min	Max	Unit	
Bus Interface Signals: DO0–DO7, DO8/CO3, DO9/CO2, CO0–CO1, DSTRB, CSTRB, IGM, CLK, CNB, VLTN						
V _{OH}	Output HIGH Voltage	V _{CC} = Min, I _{OH} = –1 mA V _{IN} = 0 or 3 V	2.4		V	
V _{OL}	Output LOW Voltage	V _{CC} = Min, I _{OL} = 8 mA V _{IN} = 0 or 3 V		0.45	V	
V _{IH}	Input HIGH Voltage	V _{CC} = Max (Note 9)	2.0		V	
V _{IL}	Input LOW Voltage	V _{CC} = Max (Note 9)		0.8	V	
V _I	Input Clamp Voltage	V _{CC} = Min, I _{IN} = –18 mA		–1.5	V	
I _{IL}	Input LOW Current	V _{CC} = Max, V _{IN} = 0.4 V		–400	μA	
I _{IH}	Input HIGH Current	V _{CC} = Max, V _{IN} = 2.7 V		50	μA	
I _I	Input Leakage Current	V _{CC} = Max, V _{IN} = 5.5 V		50	μA	
I _{SC}	Output Short Circuit Current (Note 4)		–15	–85	mA	
Serial Interface Signals: SERIN+, SERIN–						
V _{IHS}	Input HIGH Voltage SERIN+	(Notes 9, 21)	V _{CC} –1.165	V _{CC} –0.88	V	
V _{ILS}	Input LOW Voltage SERIN+	(Notes 9, 21)	V _{CC} –1.81	V _{CC} –1.475	V	
V _{THT}	Test Mode Threshold SERIN–	V _{CC} = Max		0.25	V	
V _{DIF}	Differential Input Voltage		0.3	1.1	V	
V _{ICM}	Input Common Mode Voltage	(Note 6)	3.05	V _{CC} –0.55	V	
I _{IL}	Input LOW Current	V _{CC} = Max, V _{IN} = V _{CC} – 1.81 V	0.5		μA	
I _{IH}	Input HIGH Current	V _{CC} = Max, V _{IN} = V _{CC} – 0.88 V		220	μA	
Miscellaneous Signals: X1, V_{CC1}, V_{CC2}						
V _{IHX}	Input HIGH Threshold X1		2.0		V	
V _{ILX}	Input LOW Threshold X1			0.8	V	
I _{ILX}	Input LOW Current X1	V _{IN} = 0.45 V		–900	μA	
I _{IHX}	Input HIGH Current X1	V _{IN} = 2.4 V		+600	μA	
I _{CC}	Supply Current	V _{CC1} = V _{CC2} = Max DMS = 0 V	Pin V _{CC1} (TTL)		50	mA
			Pin V _{CC2} (CML)		300	mA

SWITCHING CHARACTERISTICS (Note 20)
Am7968-175 TAXIchip Transmitter (Notes 10, 13, 22)

No.	Parameter Symbol	Parameter Description	Test Conditions	Min	Max	Units
Bus Interface Signals: DI0–DI7, DI8/CI3, DI9/CI2, CI0–CI1, STRB, ACK, CLK						
1	tp	CLK Period		5.7 n	8 n	ns
2	tpw	CLK Pulse Width HIGH		20		ns
3	tpw	CLK Pulse Width LOW		20		ns
4	tpw	STRB Pulse Width HIGH (Note 7)		15		ns
5	tpw	STRB Pulse Width LOW		15		ns
6	tbb	Internal Byte Boundary to CLK↓ (Note 11)		$\frac{-9t_1}{8n} + 9$	20	ns
9	ts	Data–STRB Setup Time		5		ns
10	th	Data–STRB Hold Time		15		ns
11	th	ACK↑ to STRB↓ Hold (Note 8)	TTL Output Load	0		ns
12	th	ACK↓ to STRB↑ Hold	TTL Output Load	0		ns
13	tpd	STRB↑ to ACK↑ (Note 18)	TTL Output Load		40	ns
14	tpd	STRB↓ to ACK↓	TTL Output Load		23	ns
15	tpd	CLK↓ to ACK↑ (Note 18)	TTL Output Load		$\frac{3t_1}{n} + 33$	ns
Serial Interface Signals: SEROUT+, SEROUT– (Note 2)						
22	tsk [†]	SEROUT± Skew	ECL Output Load	–200	+200	ps
23	tr [†]	SEROUT± Output Rise Time	ECL Output Load	.45	2	ns
24	tf [†]	SEROUT± Output Fall Time	ECL Output Load	.45	2	ns
26	tpw [†]	SEROUT ± Pulse Width LOW	ECL Output Load	$\frac{t_1}{n} - 5\%$	$\frac{t_1}{n} + 5\%$	ns
27	tpw [†]	SEROUT ± Pulse Width HIGH	ECL Output Load	$\frac{t_1}{n} - 5\%$	$\frac{t_1}{n} + 5\%$	ns
Miscellaneous Signals: X1 (Note 15)						
29	tpw	X1 Pulse Width HIGH (Note 12)	TTL Output Load on CLK	24		ns
30	tpw	X1 Pulse Width LOW (Note 12)	TTL Output Load on CLK	24		ns
32	tpd	X1↑ to CLK↑	TTL Load		32	ns
33	tpd	X1↓ to CLK↓	TTL Load		32	ns

Am7969-175 TAXIchip Receiver (Notes 13, 14, 22)

No.	Parameter Symbol	Parameter Description	Test Conditions	Min	Max	Unit
Bus Interface Signals: D00–D07, D08/CO3, D09/CO2, CO0–CO1, DSTRB, CSTRB, IGM, CLK, CNB, VLTN						
35	tp	CLK Period (Note 24)		5.7 n	8 n	ns
36	tpD	Data Valid to STRB↑ Delay	TTL Output Load	$\frac{2t_{35}}{n} - 2$		ns
37	tpD	CLK↓ to STRB↑	TTL Output Load		$\frac{2t_{35}}{n} + 15$	ns
38	tpD	CLK↑ to STRB↓	TTL Output Load	$\frac{t_{35}}{n} - 5$		ns
38a	tpD	STRB↑ to CLK↑ (Note 23)	TTL Output Load	$\frac{3t_{35}}{n} - 10$		ns
39	tpD	CLK↓ to Data Valid Delay	TTL Output Load		$-\left(\frac{t_{35}}{n}\right) + 23$	ns
40	tpW	STRB Pulse Width HIGH	TTL Output Load	$\frac{5t_{35}}{2n}$	$\frac{5t_{35}}{n}$	ns
41	tpW	CLK Pulse Width HIGH	TTL Output Load	$\frac{5t_{35}}{n} - 7$		ns
42	tpW	CLK Pulse Width LOW	TTL Output Load	$\frac{5t_{35}}{n} - 4$		ns
43	tpD	SERIN to CLK↓ Delay	TTL Output Load	$\frac{t_{35}}{2n} + 17$	$\frac{2t_{35}}{n} + 26$	ns
47A	ts	CNB↓ to CLK↑ Setup Time (Note 19)		$-\left(\frac{t_{35}}{n} - 31\right)$		ns
47B	ts	CNB↑ to CLK↓ Setup Time		29		ns
48	tH	CNB↓ to CLK↑ Hold		$\frac{2t_{35}}{n} - 3$		ns
49	tpW	CNB Pulse Width LOW		$\frac{2t_{35}}{n}$		ns
Serial Interface Signals: SERIN+, SERIN–						
57	t _J [†]	SERIN± Peak to Peak Input Jitter Tolerance (Note 16)			2	ns
Miscellaneous Signals: X1 (Note 15)						
60	tpW	X1 Pulse Width HIGH		21		ns
61	tpW	X1 Pulse Width LOW		21		ns

(Page intentionally left blank)

**Am7968/Am7969-125 MILITARY
ABSOLUTE MAXIMUM RATINGS**

Storage Temperature	-65°C to +150°C
Ambient Temperature Under Bias	-55°C to +125°C
Supply Voltage to Ground Potential Continuous	-0.5 V to +7.0 V
DC Voltage Applied to Outputs	-0.5 V to V _{CC} Max
DC Input Voltage	-0.5 V to +5.5 V
DC Output Current	±100 mA
DC Input Current	-30 mA to +5.0 mA

Stresses above those listed under Absolute Maximum Ratings may cause permanent device failure. Functionality at or above these limits is not implied. Exposure to absolute maximum ratings for extended periods may affect device reliability.

OPERATING RANGES**Military (SMD) Devices**

5962-9052701M3A	
5962-9052701MXA	
5962-9052801M3A	
5962-9052801MXA	
Temperature (T _c) -55°C to +125° C
Supply Voltage (V _{CC}) +4.75 V to +5.5 V

Military (CPL) Devices

Am7968-125/LKC	
Am7968-125/DKC	
Am7969-125/LKC	
Am7969-125/DKC	
Temperature (T _c) -30°C to +125° C
Supply Voltage (V _{CC}) +4.5 V to +5.5 V

Operating ranges define those limits between which the functionality of the device is guaranteed.

DC CHARACTERISTICS over operating range unless otherwise specified (for CPL Products Group A, Subgroups 1, 2, 3 are tested unless otherwise noted)

Am7968-125 Military TAXIchip Transmitter

Parameter Symbol	Parameter Description	Test Conditions (Note 1)		Min	Max	Unit
Bus Interface Signals: DI0–DI7, DI8/CI3, DI9/CI2, CI0–CI1, STRB, ACK, CLK						
VOH1	Output HIGH Voltage ACK	V _{CC} = Min, I _{OH} = –1 mA V _{IN} = 0 or 3 V		2.4		V
VOH2	Output HIGH Voltage CLK	V _{CC} = Min, I _{OH} = –1 mA V _{IN} = 0 or 3 V		2.4		V
VOL	Output LOW Voltage ACK, CLK	V _{CC} = Min, I _{OL} = 8 mA V _{IN} = 0 or 3 V			0.45	V
VIH	Input HIGH Voltage	V _{CC} = Max (Note 9)	T _C = –30 to +125°C	2.0		V
			T _C = –55 to +125°C	2.1		V
VIL	Input LOW Voltage	V _{CC} = Max (Note 9)			0.8	V
VI	Input Clamp Voltage	V _{CC} = Min I _{IN} = –18 mA			–1.5	V
IIL	Input LOW Current	V _{CC} = Max, V _{IN} = 0.4 V			–400	μA
IiH	Input HIGH Current	V _{CC} = Max, V _{IN} = 2.7 V			50	μA
Ii	Input Leakage Current	V _{CC} = Max, V _{IN} = 5.5 V	All Inputs Except CLK		50	μA
			CLK Input		150	μA
Isc	Output Short Circuit Current ACK, CLK	(Note 4)		–15	–85	mA
Serial Interface Signals: SEROUT+, SEROUT–						
VOH	Output HIGH Voltage	V _{CC} = Min ECL Load		V _{CC} –1.165	V _{CC} –0.88	V
VOL	Output LOW Voltage	V _{CC} = Min ECL Load		V _{CC} –1.81	V _{CC} –1.62	V
Miscellaneous Signals: X1, Vcc1, Vcc2, Vcc3						
VIHX	Input HIGH Voltage X1	V _{CC} = Max (Note 9)	T _C = –30 to +125°C	2.0		V
			T _C = –55 to +125°C	2.1		V
VILX	Input LOW Voltage X1				0.8	V
IILX	Input LOW Current X1	V _{IN} = 0.45 V			–900	μA
IiHX	Input HIGH Current X1	V _{IN} = 2.4 V			+600	μA
Icc	Supply Current	SEROUT = ECL Load, DMS = 0 V _{CC1} = V _{CC2} = V _{CC3} = Max	Pin V _{CC1} (TTL)		30	mA
			Pin V _{CC2} (ECL)		45	mA
			Pin V _{CC3} (CML)		215	mA

*See notes following end of Switching Characteristics tables.

Am7969-125 Military TAXIchip Receiver

Parameter Symbol	Parameter Description	Test Conditions (Note 1)	Min	Max	Unit
Bus Interface Signals: DO0–DO7, DO8/CO3, DO9/CO2, CO0–CO1, DSTRB, CSTRB, IGM, CLK, CNB, VLTN					
V _{OH}	Output HIGH Voltage	V _{CC} = Min, I _{OH} = –1 mA V _{IN} = 0 or 3 V	2.4		V
V _{OL}	Output LOW Voltage	V _{CC} = Min, I _{OL} = 8 mA V _{IN} = 0 or 3 V		0.45	V
V _{IH}	Input HIGH Voltage	V _{CC} = Max (Note 9)	2.0		V
V _{IL}	Input LOW Voltage	V _{CC} = Max (Note 9)		0.8	V
V _I	Input Clamp Voltage	V _{CC} = Min, I _{IN} = –18 mA		–1.5	V
I _{IL}	Input LOW Current	V _{CC} = Max, V _{IN} = 0.4 V		–400	μA
I _{IH}	Input HIGH Current	V _{CC} = Max, V _{IN} = 2.7 V		50	μA
I _I	Input Leakage Current	V _{CC} = Max, V _{IN} = 5.5 V		50	μA
I _{SC}	Output Short Circuit Current (Note 4)		–15	–85	mA
Serial Interface Signals: SERIN+, SERIN–					
V _{IHS}	Input HIGH Voltage SERIN+	(Notes 9, 21)	V _{CC} –1.165	V _{CC} –0.88	V
V _{ILS}	Input LOW Voltage SERIN+	(Notes 9, 21)	V _{CC} –1.81	V _{CC} –1.475	V
V _{THT}	Test Mode Threshold SERIN–	V _{CC} = Max		0.25	V
V _{DIF}	Differential Input Voltage		0.3	1.1	V
V _{ICM}	Input Common Mode Voltage	(Note 6)	3.05	V _{CC} –0.55	V
I _{IL}	Input LOW Current	V _{CC} = Max, V _{IN} = V _{CC} –1.81 V	0.5		μA
I _{IH}	Input HIGH Current	V _{CC} = Max, V _{IN} = V _{CC} –0.88 V		220	μA
Miscellaneous Signals: X1, V_{CC1}, V_{CC2}					
V _{IHX}	Input HIGH Threshold X1		2.0		V
V _{ILX}	Input LOW Threshold X1			0.8	V
I _{ILX}	Input LOW Current X1	V _{IN} = 0.45 V		–900	μA
I _{IHX}	Input HIGH Current X1	V _{IN} = 2.4 V		+600	μA
I _{CC}	Supply Current	V _{CC1} = V _{CC2} = Max DMS = 0 V	Pin V _{CC1} (TTL)	55	mA
			Pin V _{CC2} (CML)	335	mA

SWITCHING CHARACTERISTICS over operating range unless otherwise specified
 (Note 20) (for CPL Products Group A, Subgroups 9, 10, and 11 are tested unless otherwise noted)

Am7968-125 Military TAXIchip Transmitter (Notes 10, 13, 22)

No.	Parameter Symbol	Parameter Description	Test Conditions	Min	Max	Units
Bus Interface Signals: DI0–DI7, DI8/CI3, DI9/CI2, CI0–CI1, STRB, ACK, CLK						
1	t _P	CLK Period		8 n	25 n	ns
2	t _{PW}	CLK Pulse Width HIGH		25		ns
3	t _{PW}	CLK Pulse Width LOW		25		ns
4	t _{PW}	STRB Pulse Width HIGH (Note 7)		20		ns
5	t _{PW}	STRB Pulse Width LOW		20		ns
6	t _{BB}	Internal Byte Boundary to CLK↓ (Note 11)		$\frac{-9t_i}{8n} + 3$	25	ns
9	t _S	Data–STRB Setup Time		10		ns
10	t _H	Data–STRB Hold Time		15		ns
11	t _H	ACK↑ to STRB↓ Hold (Note 8)	TTL Output Load	0		ns
12	t _H	ACK↓ to STRB↑ Hold	TTL Output Load	0		ns
13	t _{PD}	STRB↑ to ACK↑ (Note 18)	TTL Output Load		45	ns
14	t _{PD}	STRB↓ to ACK↓	TTL Output Load		25	ns
15	t _{PD}	CLK↓ to ACK↑ (Note 18)	TTL Output Load		$\frac{3t_i}{n} + 43$	ns
Miscellaneous Signals: X1 (Note 15)						
29	t _{PW}	X1 Pulse Width HIGH (Note 12)	TTL Output Load on CLK	35		ns
30	t _{PW}	X1 Pulse Width LOW (Note 12)	TTL Output Load on CLK	35		ns
32	t _{PD}	X1↑ to CLK↑	TTL Load		32	ns
33	t _{PD}	X1↓ to CLK↓	TTL Load		32	ns

Am7969-125 Military TAXIchip Receiver (Notes 13, 14, 22)

No.	Parameter Symbol	Parameter Description	Test Conditions	Min	Max	Unit
Bus Interface Signals: DO0–DO7, DO8/CO3, DO9/CO2, CO0–CO1, DSTRB, CSTRB, IGM, CLK, CNB, VLTN						
35	t _P	CLK Period (Note 24)		8 n	25 n	ns
36	t _{PD}	Data Valid to STRB↑ Delay	TTL Output Load	$\frac{2t_{35}}{n}$		ns
37	t _{PD}	CLK↓ to STRB↑	TTL Output Load		$\frac{2t_{35}}{n} + 15$	ns
38	t _{PD}	CLK↑ to STRB↓	TTL Output Load	$\frac{t_{35}}{n} - 7$		ns
38a	t _{PD}	STRB↑ to CLK↑ (Note 23)	TTL Output Load	$\frac{3t_{35}}{n} - 14$		ns
39	t _{PD}	CLK↓ to Data Valid Delay	TTL Output Load		$-\left(\frac{t_{35}}{n}\right) + 23$	ns
40	t _{PW}	STRB Pulse Width HIGH	TTL Output Load	$\frac{5t_{35}}{2n}$	$\frac{5t_{35}}{n}$	ns
41	t _{PW}	CLK Pulse Width HIGH	TTL Output Load	$\frac{5t_{35}}{n} - 15$		ns
42	t _{PW}	CLK Pulse Width LOW	TTL Output Load	$\frac{5t_{35}}{2n} - 15$		ns
43	t _{PD}	SERIN to CLK↓ Delay	TTL Output Load	$\frac{t_{35}}{2n} + 17$	$\frac{2t_{35}}{n} + 26$	ns
Serial Interface Signals: SERIN+, SERIN–						
57	t _J [†]	SERIN± Peak to Peak Input Jitter Tolerance (Note 16)			5	ns
Miscellaneous Signals: X1 (Note 15)						
60	t _{PW}	X1 Pulse Width HIGH		35		ns
61	t _{PW}	X1 Pulse Width LOW		35		ns

Note:

CLK (pin 19) must be connected to CNB (pin 24).

Notes:*

1. For conditions shown as Min or Max use the appropriate value specified under operating range.
2. The clock fall to serial output delay is typically 3 bit times.
4. Not more than one output should be shorted at a time. Duration of the short circuit test should not exceed one second.
5. If the $CNB\uparrow$ to $CLK\uparrow$ setup time is violated, IGM will stay LOW.
6. Voltage applied to either $SERIN\pm$ pins must not be above V_{CC} nor below +2.5 V to assure proper operation.
7. t_4 guarantees that data is latched. ACK (t_{11}) timing may not be valid.
8. If t_{11} is not met, ACK response and timing are not guaranteed, but data will still be latched on $STRB\uparrow$ (see t_4).
9. Measured with device in Test mode while monitoring output logic states.
10. For the TAXI Transmitter, "n" is determined by the following table:

DMS	TLS	"n"	
GND	OPEN	n = 1;	8 Bit Test Mode 2
	GND/ V_{CC}	n = 10;	8 Bit Local/Test Mode 1
V_{CC}	OPEN	n = 1;	9 Bit Test Mode 2
	GND/ V_{CC}	n = 11;	9 Bit Local/Test Mode 1
Open or $\frac{1}{2} V_{CC}$	OPEN	n = 1;	10 Bit Test Mode 2
	GND/ V_{CC}	n = 12;	10 Bit Local/Test Mode 1

11. t_6 (Internal Byte Boundary to $CLK\downarrow$) is created by the variation of internal STRB propagation delays relative to internal byte boundaries over temperatures and V_{CC} . The internal byte boundary determines the byte in which data will come out ($SEROUT\pm$). If STRB occurs before the byte boundary, then the data will be sent out two bytes later. If STRB occurs after the byte boundary, then the output data will be delayed by one additional byte.
12. X1 Pulse Width is measured at a point where CLK output equals t_2 or t_3 .
13. For the TAXI Transmitter, 'Data' is either $DI0 - DI7$, $DI8/CI3$, $DI9/CI2$, $CI0 - CI1$. For the TAXI Receiver, 'STRB' is either CSTRB or DSTRB and 'Data' is either $DO0 - DO7$, $DO8/CO3$, $DO9/CO2$, $CO0 - CO1$.
14. For the TAXI Receiver, 'n' is determined by the state of the DMS and $SERIN-$ inputs. When $SERIN-$ is held below $V_{THT\ max}$ or left open, $n=1$. When $SERIN-$ is held above 0.25 V and when:

DMS	$SERIN-$	"n"	
GND	< $V_{THT\ max}$ or OPEN	n = 1;	8 Bit Test Mode
	> 2.5 V	n = 10;	8 Bit Local Mode
V_{CC}	< $V_{THT\ max}$ or OPEN	n = 1;	9 Bit Test Mode
	> 2.5 V	n = 11;	9 Bit Local Mode
Open or $\frac{1}{2} V_{CC}$	< $V_{THT\ max}$ or OPEN	n = 1;	10 Bit Test Mode
	> 2.5 V	n = 12;	10 Bit Local Mode

- 15. Jitter on X1 input must be less than ± 0.2 ns to ensure that automatic test equipment can properly measure device switching characteristics. The X1 input frequency will determine the byte rate reference for the receiver byte clock.
- 16. This specification is the sum of Data Dependent Jitter, Duty Cycle Distortion, and Random Jitter.
- 18. ACK delay is determined by t_{13} when the input latch is empty or by t_{15} when the latch is full (Busy mode). Also note that ACK will not rise if STRB does not remain HIGH until ACK rises.
- 19. If t_{47A} (CNB \emptyset to CLK setup) is violated, then output data will occur one byte time later.
- 20. All timing references are made with respect to +1.5 V for TTL-level signals or to the 50% point between V_{OH} and V_{OL} for ECL signals. ECL input rise and fall times must be 2 ns \pm 0.2 ns between 20% and 80% points. TTL input rise and fall times must be 2 ns between 1 V and 2 V.
- 21. Device thresholds on the SERIN (+/-) pin(s) are verified during production test by ensuring that the input threshold is less than V_{IHS} (min) and greater than V_{ILS} (max). The figure below shows the acceptable range (shaded area) for the transition voltage.

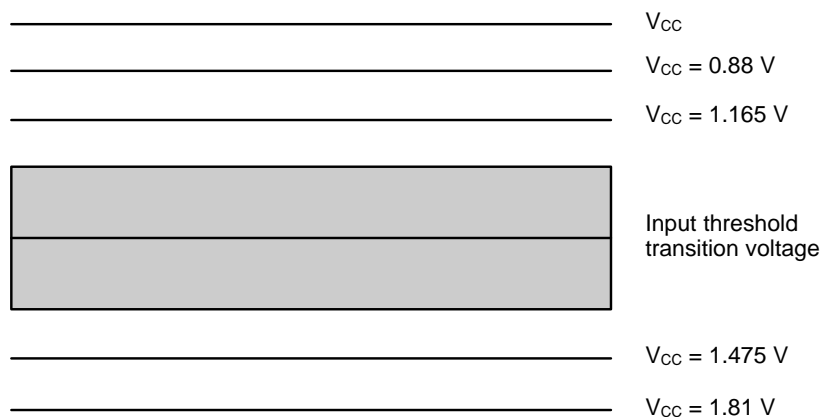

- 22. Switching Characteristics are tested during 8-bit local mode operation.
- 23. The limit for this parameter cannot be derived from t_{37} and t_{42} .
- 24. This specification does not apply during reacquisition when CLK stretch can occur.
- † This parameter is guaranteed but is not included in production tests.
- * Notes listed correspond to the respective references made in the DC Characteristics and the Switching Characteristics tables.

SWITCHING TEST CIRCUITS

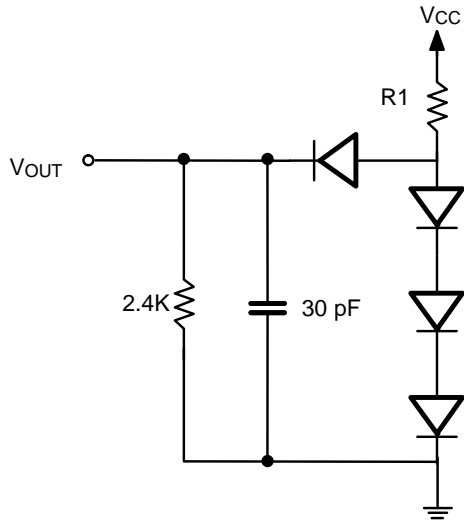

07370F-14

TTL Output Load

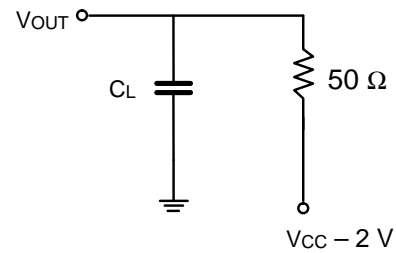

07370F-15

ECL Output Load

Notes:

1. $R1 = 500 \Omega$ for the $I_{OL} = 8 \text{ mA}$
2. All diodes IN916 or IN3064, or equivalent
3. $C_L = 30 \text{ pF}$ includes scope probe, wiring and stray capacitances without device in test fixture.
4. AMD uses constant current (A.T.E.) load configurations and forcing functions. This figure is for reference only.

Notes:

1. $C_L < 3 \text{ pF}$ includes scope probe, wiring and stray capacitances without device in test fixture.
2. AMD uses Automatic test equipment load configurations and forcing functions. This figure is for reference only.

SWITCHING TEST WAVEFORMS



07370F-16

TTL Input Waveform

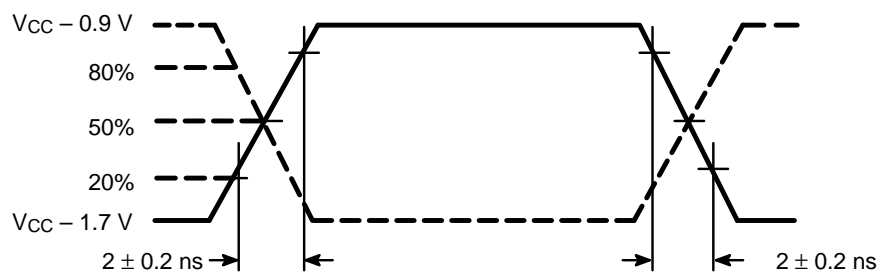

07370F-17

ECL Input Waveform

KEY TO SWITCHING WAVEFORMS

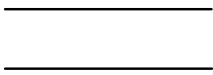
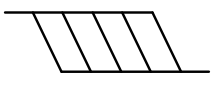
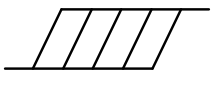
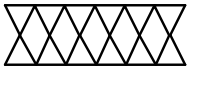
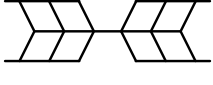
WAVEFORM	INPUTS	OUTPUTS
	Must Be Steady	Will Be Steady
	May Change from H to L	Will Be Changing from H to L
	May Change from L to H	Will Be Changing from L to H
	Don't Care Any Change Permitted	Changing State Unknown
	Does Not Apply	Center Line is High Impedence "Off" State

KS000010

SWITCHING WAVEFORMS

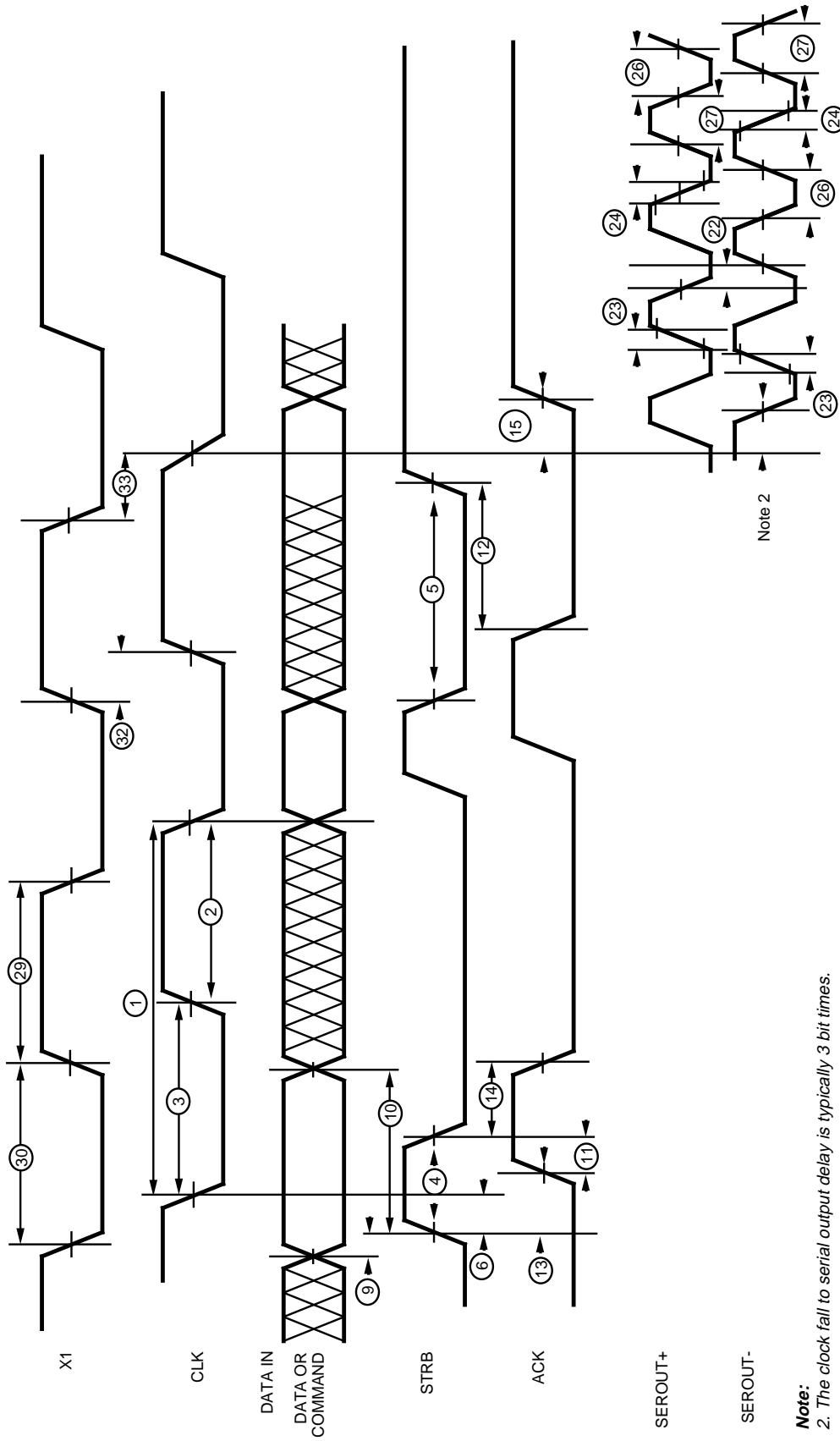

07370F-18

Am7968 TAXIchip Transmitter AC

SWITCHING WAVEFORMS

TAXIchip Transmitter

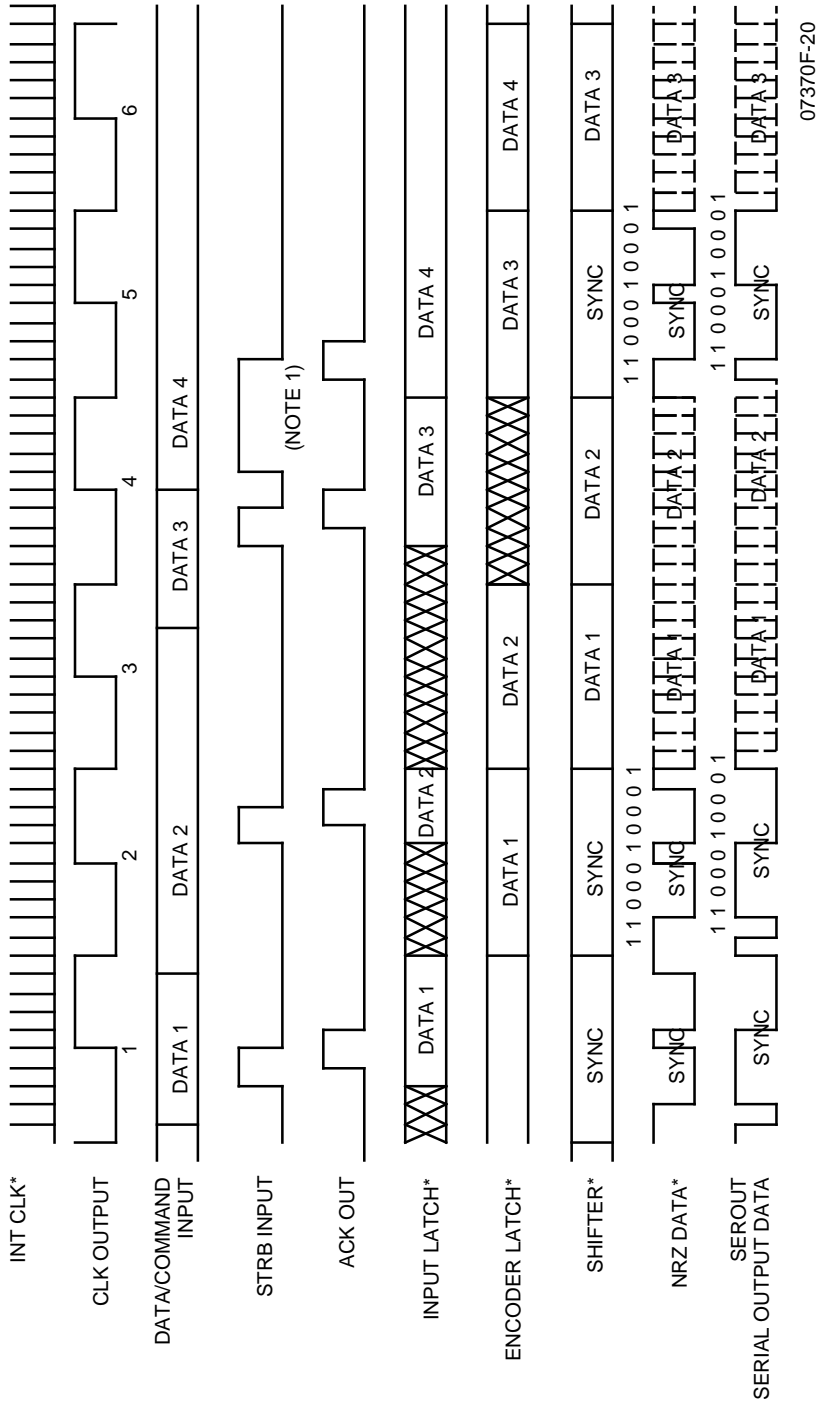

07370F-20

Note:

1. The input Latch is BUSY when the second STRB comes in; the internal STRB-ACK is delayed until the next CLK window. Refer to Figure 3.

STRB to SEROUT Timing (8-Bit Local Mode)
*Internal Signals

SWITCHING WAVEFORMS

TAXIchip Receiver

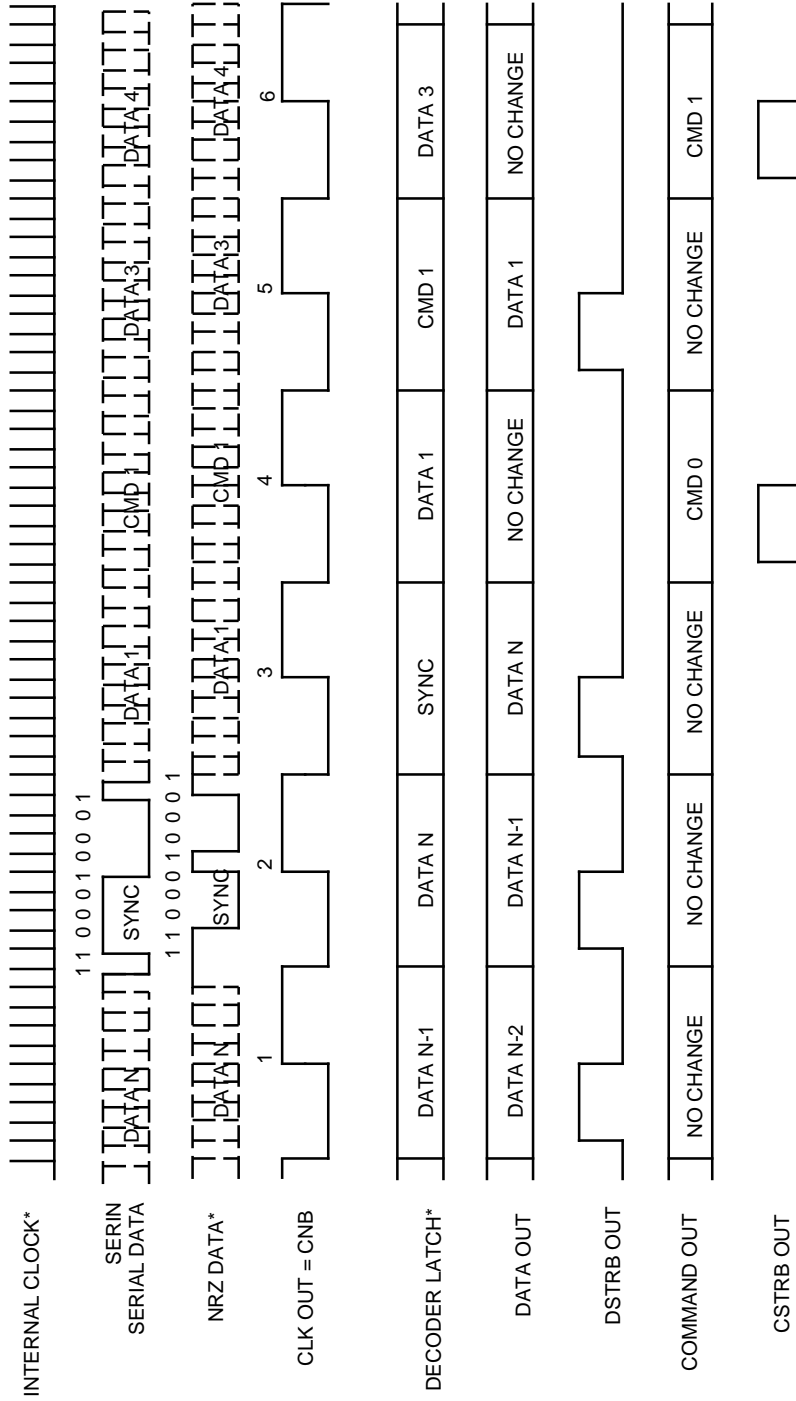

TAXIchip Receiver Timing
(8-Bit Local Mode)

07370F-21

SWITCHING WAVEFORMS

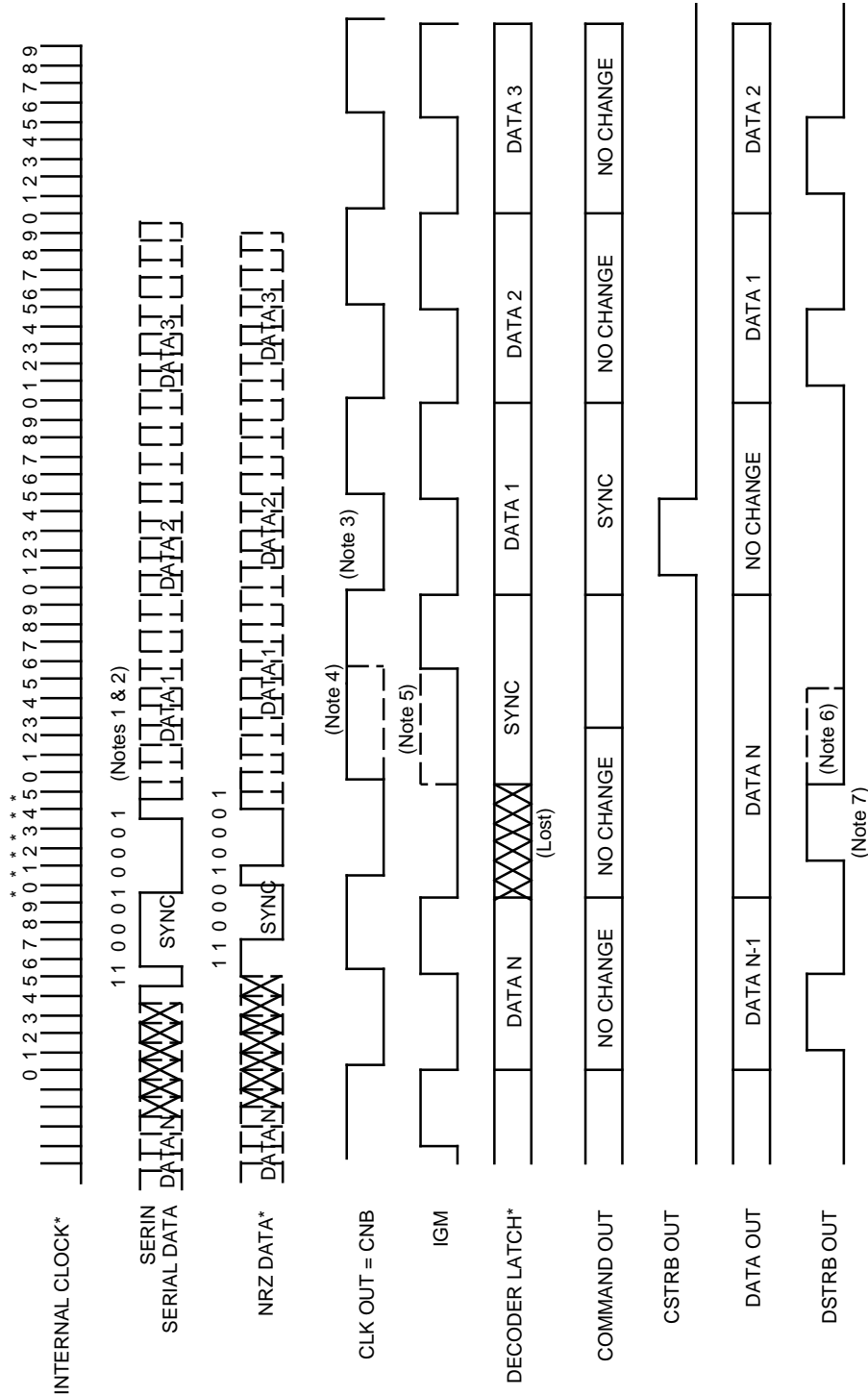

TAXIchip Receiver Timing (8-Bit Mode/Local) Showing External Effect of SYNC Error

SWITCHING WAVEFORMS

TAXIchip Receiver

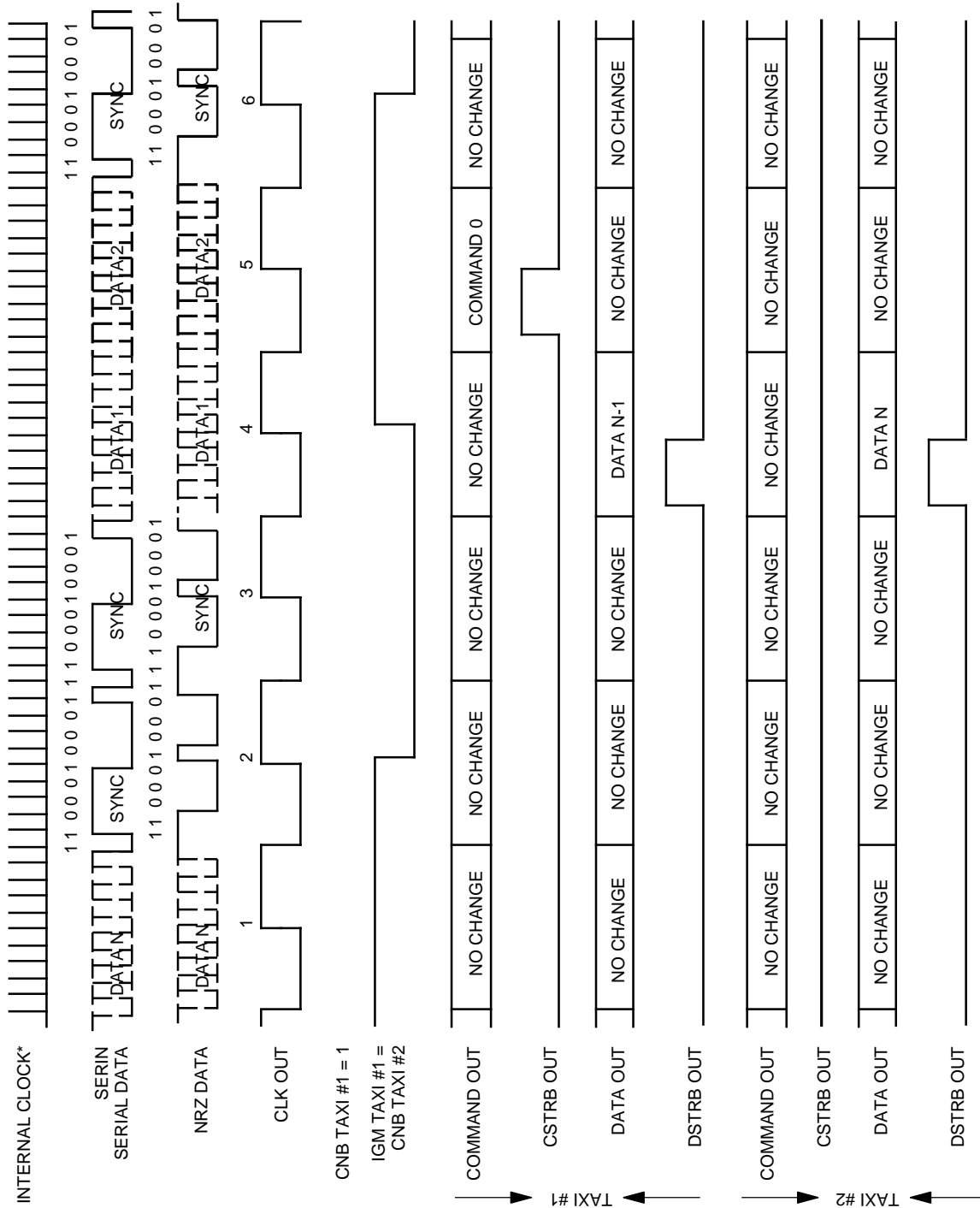

07370F-23

TAXIchip Receiver Timing
(8-Bit Cascade Mode)

PHYSICAL DIMENSIONS*

CD 028

28-Pin Ceramic DIP (measured in inches)

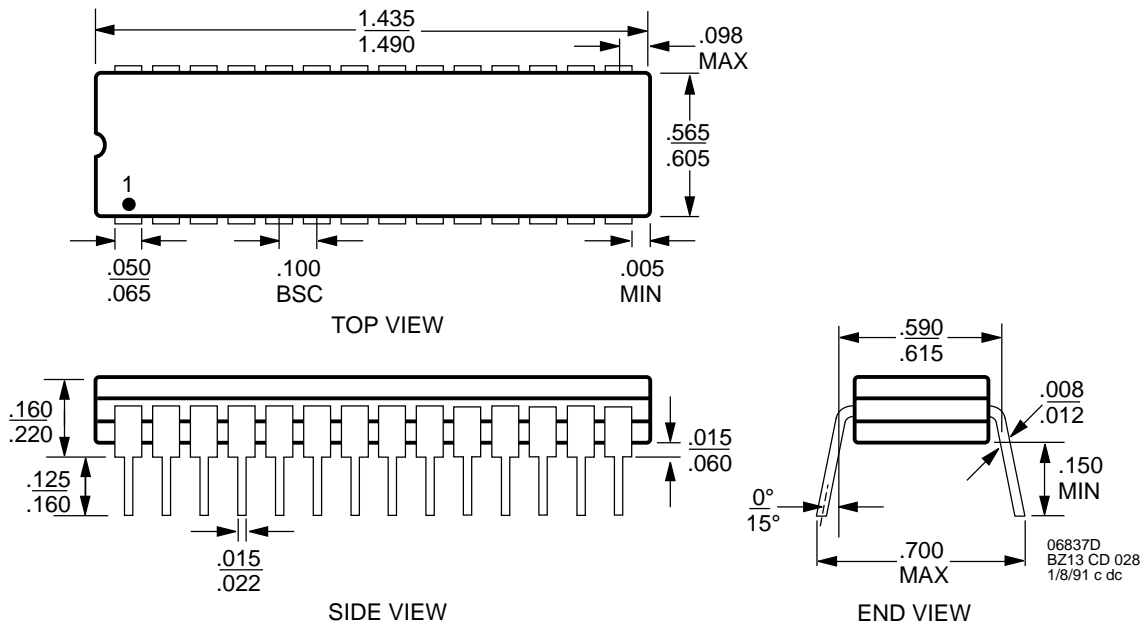

PL 028

**28-Pin Plastic Leaded Chip Carrier
(measured in inches)**

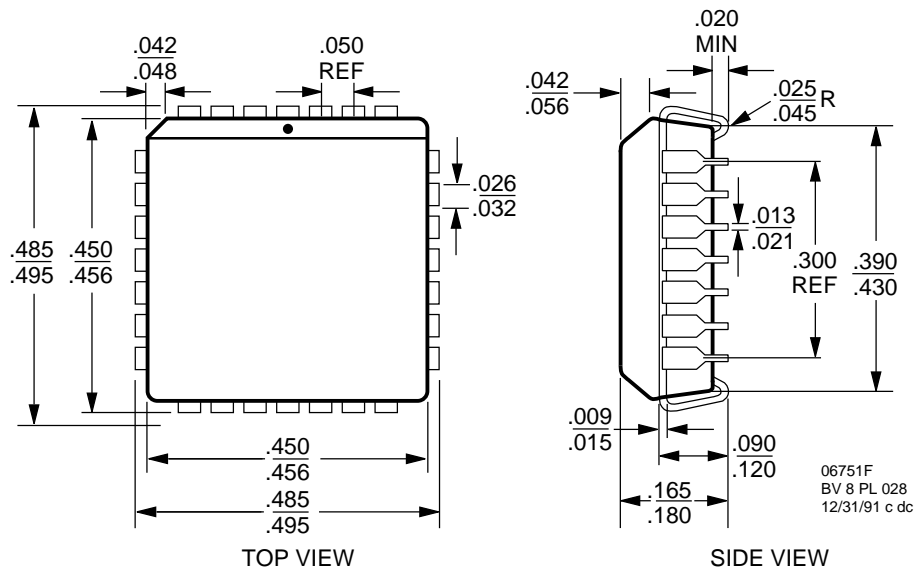

*For reference only. All dimensions measured in inches. BSC is an ANSI standard for Basic Space Centering.

PHYSICAL DIMENSIONS
CLT028
28-Pin Ceramic Leadless Chip Carrier
(measured in inches)

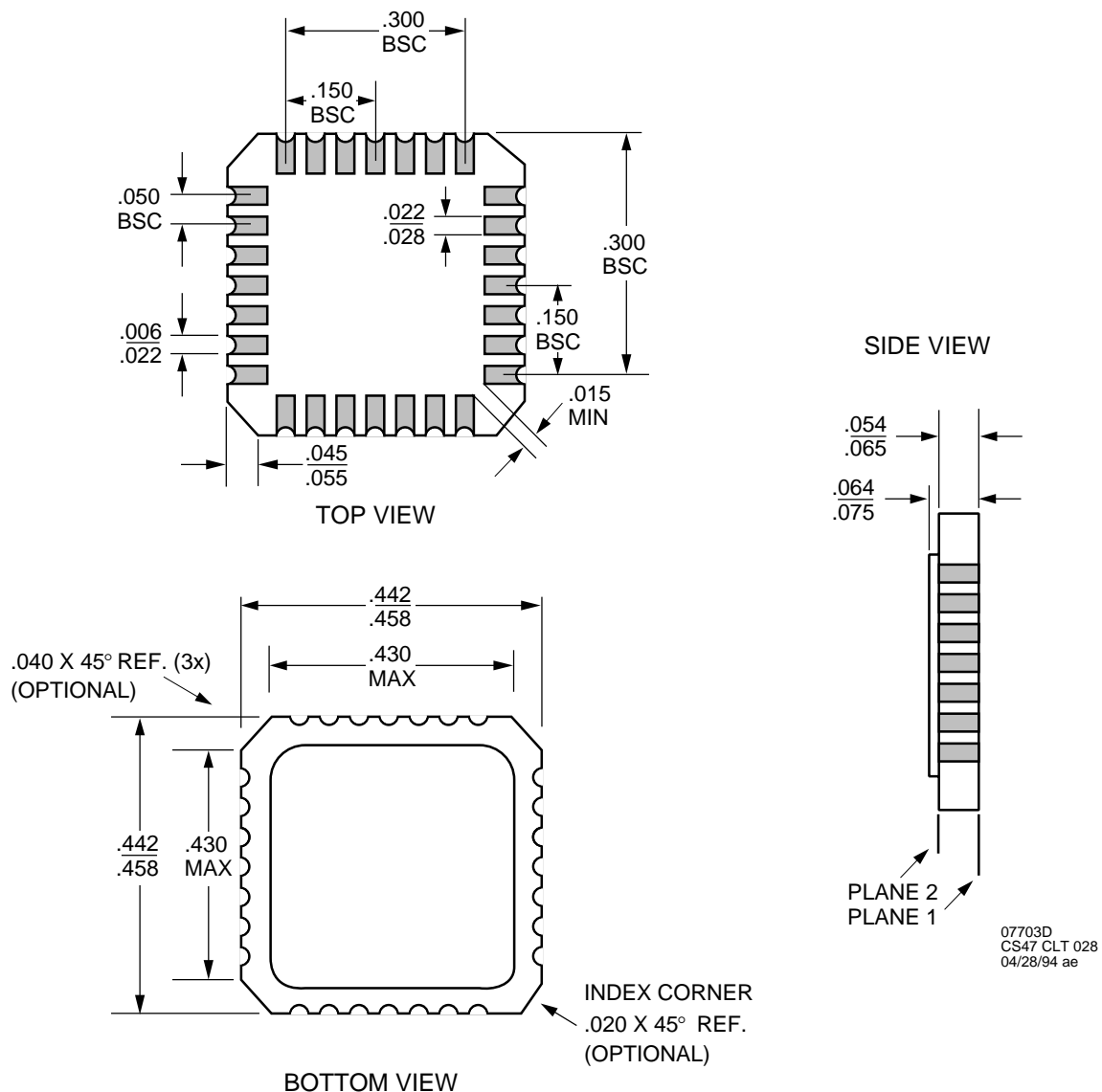

TAXIchip™ Integrated Circuits

Technical Manual



1.0 INTRODUCTION

Modern electronic systems move data from point-to-point across physical layer boundaries using either serial or parallel data links. Parallel data links provide fast data transfers and are compatible with most computer architectures. However, conventional parallel data links are burdened with cost/performance issues such as costly multi-conductor cables, crosstalk, RFI, bit-to-bit skew and other concerns associated with multiple wire interfaces. Serial data links, although simpler and less costly, have not provided sufficient bandwidth to compete with the high data transfer rates of parallel links.

Recent technological advances have altered the cost performance trade-off between serial and parallel data transfer techniques. A new chip set from Advanced Micro Devices offers a high performance integrated alternative to traditional serial/parallel data transfer techniques. The TAXIchip set (Transparent Asynchronous Xmitter-Receiver Interface) provides the means to establish a transparent high speed serial link between two high performance parallel buses. The TAXIchip set consists of a Transmitter, which takes parallel data and transmits it serially at up to 175 MHz, and a Receiver, which converts the serial data stream back to parallel form. TAXIchips provide a simple parallel interface through a high speed serial link, while maintaining the data bandwidth required by the system.

1.1 The Am7968 TAXI Transmitter

The TAXI™ Transmitter consists of an input latch, an encoder, a parallel to serial shift register, a multiplying Phase Locked Loop (PLL), and some control logic (Figure 1-1). Data are input to the latch, encoded, and shifted out at the serial data rate. The encoding used is the efficient 4B/5B scheme specified for the ANSI X3T9.5 Fiber Distributed Data Interface (FDDI specification). This encoding divides an 8-bit byte into two, 4-bit nibbles. Each nibble is encoded into a 5-bit symbol. The 10-bit encoded byte is formatted into an NRZI data stream for output to the media. This 4B/5B encoding is 80% efficient, using a 125 Mbaud transmission rate to send 100 Mbps of data.

The Am7968 Transmitter has differential pseudo-ECL (referenced to +5 V) outputs which can drive 50 Ω lines. This capability makes it easy to directly interface with shielded twisted pair or coaxial cables.

The pseudo-ECL outputs are also compatible with the ECL interface of optical components used to drive fiber optic cable. In addition to providing high bandwidth and low attenuation, fiber optic data transmission also offers noise immunity, eliminates RFI and provides data security. Declining optical components costs are bringing the advantages of fiber optic data transmission to an ever wider range of applications, from process control to avionics. The TAXIchip set is the ideal complement for fiber optic interfaces.

Figure 1-1 Am7968 TAXI Transmitter Block Diagram

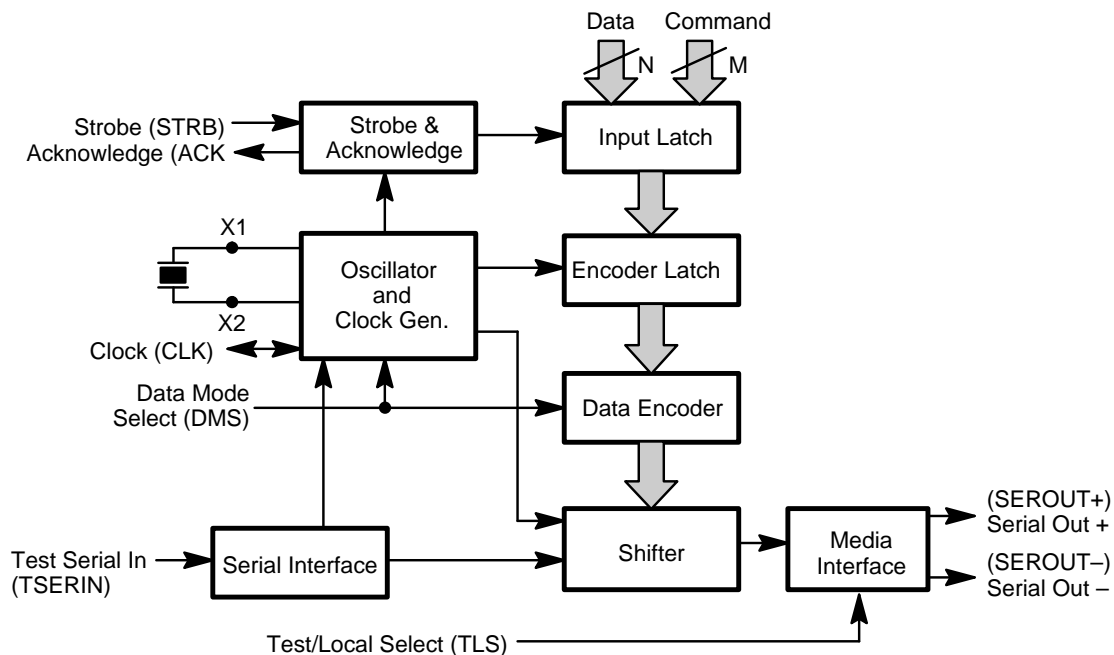

Note: N can be 8, 9, or 10 bits. Total of N + M = 12.

12330E-1

Figure 1-2 Am7969 TAXI Receiver Block Diagram

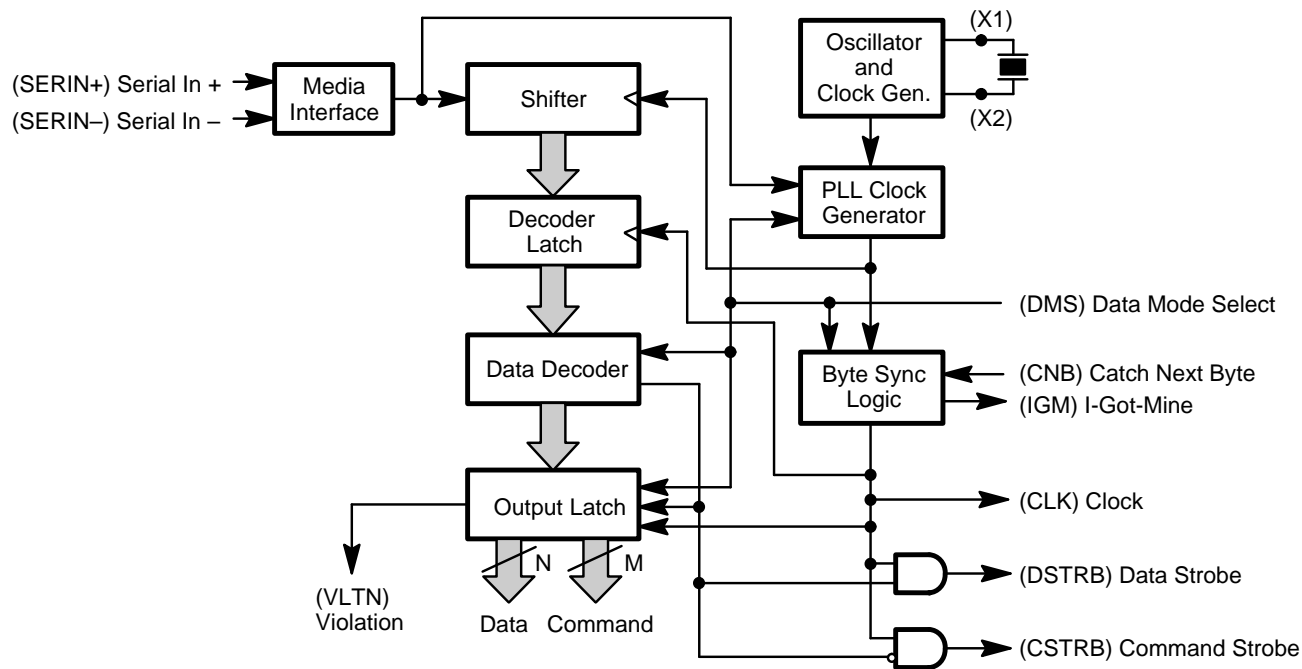

Note: N can be 8, 9, or 10 bits. Total of N + M = 12.

12330E-2

1.2 The Am7969 TAXI Receiver

The TAXI Receiver (Figure 1-2) accepts the encoded data stream into a serial-to-parallel converter, decodes and outputs the received data with an accompanying strobe. An on-chip data tracking PLL performs the necessary clock recovery from the input serial data stream.

2.0 USING THE TAXIchip SET

The current TAXIchip set has a maximum effective data throughput of 140 Mbps, over ten times faster than the data rate of conventional RS-422 drivers and receivers. The TAXIchip set has a frequency range of 40 MHz to 175 MHz corresponding to a parallel data transfer rate of 4 to 17.5 Mbyte/sec. Data rates of less than 4 Mbyte/sec are accommodated by the automatic insertion of Sync symbols in the absence of new data or commands.

The TAXI Transmitter accepts parallel input data with a simple Strobe/Acknowledge handshake, while the Receiver asserts an output strobe when data is available at its parallel outputs. The high speed serial-to-parallel conversions and data encoding/decoding are transparent to the user, who sees only an effective parallel transfer rate of up to 17.5 Mbyte/sec (see Figure 2-1). Appendix C, TAXI TIP # 89-07 addresses the use of synchronous and asynchronous strobes.

It is important to note here that the user is not forced to supply data at the maximum byte rate equivalent of the serial data rate. Data or Commands are sent down the serial link only when the user strobes the Transmitter. For those byte clock cycles when the Transmitter is not strobed, it automatically sends a special *Sync* symbol down the link. The Sync symbol is a unique bit pattern which cannot be confused with any other valid pattern.

For this reason, Sync is used to establish byte framing at the Receiver. See Appendix C, TAXI TIP # 89-03 *proper use of TAXI Sync*. It also keeps the link active when no other symbols are being sent, maintaining Receiver PLL lock. Sync will not over-write data already present in the receiver's output data latch. The serial rate is, therefore, truly transparent to the user; at input data rates less than the equivalent serial bit rate, the TAXI Transmitter will fill the gaps with Syncs, which do not disturb Receiver output data.

2.1 Data and Command

The Am7968 TAXI Transmitter and the Am7969 TAXI Receiver interface directly to an 8, 9, or 10 bit data bus. Each TAXIchip has 12 parallel interface lines which are designated as either Command or Data bits. Command bits implement user defined system supervisory functions, such as *Initialize Your System*, *Re-try*, *Halt*, or *Error* which cannot be embedded in the ordinary data path.

Figure 2-1 Basic TAXIchip Operation

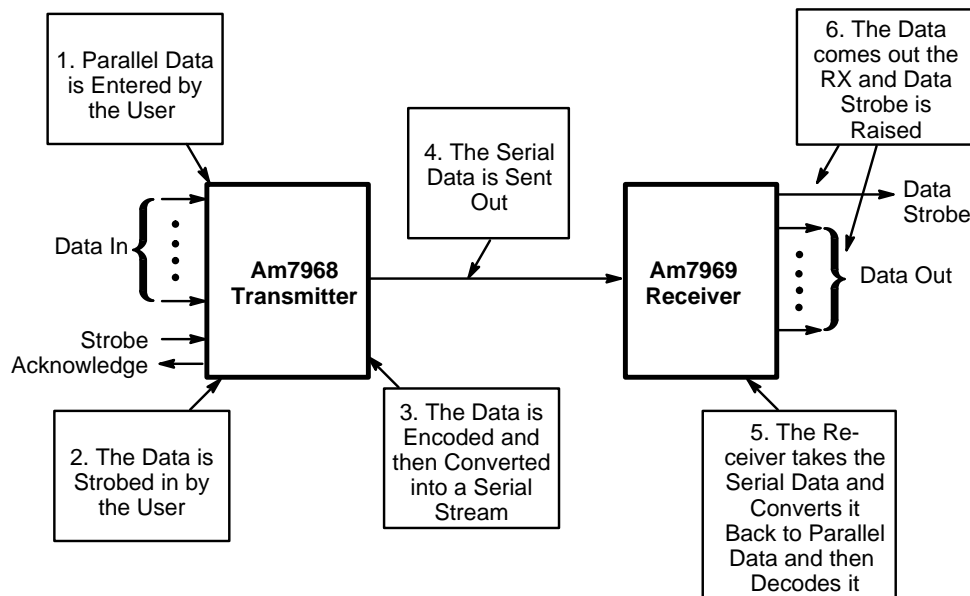

12330E-3

Three different widths are possible: 8 Data and 4 Command bits, 9 Data and 3 Command bits, and 10 Data and 2 Command bits. This choice of data and control bus widths allows flexibility to meet different system bus width requirements, while providing the capability of merging control and data into a common data stream.

2.2 Operational Modes: Local, Cascade and Test

A TAXIchip set point-to-point link can be operated in one of three modes: Local, Cascade, or Test. Local mode consists of a single Transmitter communicating with a single Receiver over the serial medium. Cascade mode for Am7968/7969-125 consists of a single Transmitter driving two or more daisy chained (cascaded) Receivers over a single serial medium. Cascade Operation for Am7968/Am7969-175 consists of a single Transmitter driving a single Receiver as shown in Appendix C, TAXI TIPS #13 and #14. Cascade mode permits direct interface with 16-bit, 32-bit and wider busses. The link may be operated in any of the above modes using the TAXI's internal PLL for bit rate generation and tracking, or the link may be run in Test Mode with external frequency multiplying and data tracking PLLs.

3.0 DATA ENCODING, VIOLATION AND SYNCs

3.1 Data Encoding

Any form of serial data transmission requires some form of encoding before the data are output to the transmission medium. Encoding is the process of converting a set of m data bits to a set of n code bits.

The purpose of the encoding operation is to include clock information in the data stream. Without this timing information, the Receiver would not be able to distinguish adjacent bits of the same value. For example, if we transmit a thousand ONEs followed by a ZERO, the Receiver might detect only 999 ONEs, or perhaps 1001 ONEs, followed by one or two ZEROs. An accurate clock is needed to tell the Receiver when to sample the incoming bit stream to determine if the bit is a ONE or a ZERO. Since the Transmitter and Receiver have only one data path between them, the clock (timing) information must be included in the serial data stream.

The TAXIchip set uses 4B/5B or 5B/6B coding, so that m is either 4 or 5, and n is either 5 or 6. In 8-bit mode, each 4-bit nibble is presented to one of two 4B/5B encoders to produce 10 code bits, 5 from each encoder. In 9-bit mode, the more significant 4B/5B encoder is replaced with a 5B/6B encoder to yield a total of 11 code bits. In 10-bit mode, both encoders are replaced with 5B/6B encoders, yielding a total of 12 code bits.

The TAXIchip set can encode two types of data: either 8, 9, or 10-bit Data, or Commands. Commands are special symbols which are typically used as control functions at the receiving end of the link. Commands may be four, three, or two bits wide, corresponding to a Data width of eight, nine, or ten bits respectively. The presence of any non-ZERO bits on the Command inputs when STRB is asserted will cause a Command symbol to be sent, regardless of the state of the Data lines. The Command bits are encoded into 10, 11, or 12 bit groupings which are special cases of the 4B/5B or 5B/6B code not used for Data.

In the absence of Data or Commands, a unique symbol (Sync) is automatically generated to maintain link synchronization. If the user has not supplied a STRB during a byte, a Sync symbol is sent.

NRZI stands for Non-Return to Zero, Invert on one. Logic ONEs are indicated by a transition, while logic ZEROs produce no transition. Further encoding the 4B/5B encoded data in this way ensures that the Receiver PLL will get a transition at least every three clock times (the maximum number of ZEROs in the 4B/5B code). Since a PLL can make a phase comparison and initiate a correction only at a transition, maximizing the number of transitions helps to keep the loop solidly in lock.

Table 3-1 TAXIchip Encoder Patterns

4B/5B ENCODER SCHEME			5B/6B ENCODER SCHEME		
HEX Data	4-Bit Binary Data	5-Bit Encoded Symbol	HEX Data	5-Bit Binary Data*	6-Bit Encoded Symbol
0	0000	11110	00	00000	110110
1	0001	01001	01	00001	010001
2	0010	10100	02	00010	100100
3	0011	10101	03	00011	100101
4	0100	01010	04	00100	010010
5	0101	01011	05	00101	010011
6	0110	01110	06	00110	010110
7	0111	01111	07	00111	010111
8	1000	10010	08	01000	100010
9	1001	10011	09	01001	110001
A	1010	10110	0A	01010	110111
B	1011	10111	0B	01011	100111
C	1100	11010	0C	01100	110010
D	1101	11011	0D	01101	110011
E	1110	11100	0E	01110	110100
F	1111	11101	0F	01111	110101
			10	10000	111110
			11	10001	011001
			12	10010	101001
			13	10011	101101
			14	10100	011010
			15	10101	011011
			16	10110	011110
			17	10111	011111
			18	11000	101010
			19	11001	101011
			1A	11010	101110
			1B	11011	101111
			1C	11100	111010
			1D	11101	111011
			1E	11110	111100
			1F	11111	111101

*** Notes:**

HEX data is parallel input data which is represented by the 4- or 5-bit binary data listed in the column to the immediate right of HEX data. Binary bits are listed from left to right in the following order.

8-Bit Mode: D7, D6, D5, D4, (4-Bit Binary), and D3, D2, D1, D0, (4-Bit Binary)

9-Bit Mode: D8, D7, D6, D5, D4, (5-Bit Binary), and D3, D2, D1, D0, (4-Bit Binary)

10-Bit Mode: D8, D7, D6, D5, D4, (5-Bit Binary), and D9, D3, D2, D1, D0, (5-Bit Binary)

Serial bits are shifted out with the most significant bit of the most significant nibble coming out first.

Table 3-2 TAXIchip Command Symbols

Am7968 Transmitter				Am7969 Receiver	
Command Input				Command Output	
HEX	Binary	Encoded Symbol	Mnemonic	HEX	Binary
8-Bit Mode					
0	0000	XXXXXX XXXXX	Data	No Change (Note 2)	No Change (Note 2)
No STRB (Note 1)	No STRB (Note 1)	11000 10001	JK (8-bit Sync)	0	0000
1	0001	11111 11111	I I	1	0001
2	0010	01101 01101	TT	2	0010
3	0011	01101 11001	TS	3	0011
4	0100	11111 00100	I H	4	0100
5	0101	01101 00111	TR	5	0101
6	0110	11001 00111	SR	6	0110
7	0111	11001 11001	SS	7	0111
8 (Note 3)	1000	00100 00100	HH	8	1000
9	1001	00100 11111	HI	9	1001
A (Note 3)	1010	00100 00000	HQ	A	1010
B	1011	00111 00111	RR	B	1011
C	1100	00111 11001	RS	C	1100
D (Note 3)	1101	00000 00100	QH	D	1101
E (Note 3)	1110	00000 11111	Q I	E	1110
F (Note 3)	1111	00000 00000	QQ	F	1111
9-Bit Mode					
0	000	XXXXXX XXXXX	Data	No Change (Note 2)	No Change (Note 2)
No STRB (Note 1)	No STRB (Note 1)	011000 10001	LK (9-bit Sync)	0	000
1	001	111111 11111	I'I	1	001
2	010	011101 01101	T'T	2	010
3	011	011101 11001	T'S	3	011
4	100	111111 00100	I'H	4	100
5	101	011101 00111	T'R	5	101
6	110	111001 00111	S'R	6	110
7	111	111001 11001	S'S	7	111
10-Bit Mode					
0	00	XXXXXX XXXXXX	Data	No Change (Note 2)	No Change (Note 2)
No STRB (Note 1)	No STRB (Note 1)	011000 100011	LM (10-bit Sync)	0	00
1	01	111111 111111	I'I'	1	01
2	10	011101 011101	T'T'	2	10
3	11	011101 111001	T'S'	3	11

Notes:

1. Command pattern Sync cannot be explicitly sent by Am7968 Transmitter with any combination of inputs and STRB, but is used to pad between user data.
2. A strobe with all 0s on the Command input lines will cause Data to be sent. See Table 3-1.
3. While these Commands are legal data and will not disrupt normal operation if used occasionally, they may cause data errors if grouped into recurrent fields. Normal PLL operation cannot be guaranteed if one or more of these Commands is continuously repeated.

3.2 Violation Logic

The TAXI Receiver logic has been designed to detect the most common types of transmission errors. It detects these errors by completely decoding the incoming data patterns, and recognizes the following types of VIOLATIONS:

1. Illegal, reserved or unused data patterns (pure Violations).
2. Unused COMMAND combinations.
3. COMMAND in Upper half and DATA in Lower half pattern.
4. DATA in Upper half and COMMAND in Lower half pattern.

Type 1 and 2 VIOLATIONS are decoded and interpreted as either DATA or COMMAND outputs with the appropriate STRB output. Type 3 & 4 VIOLATIONS are decoded as COMMAND outputs with a CSTROBE output (even though one half would have been transformed DATA/COMMAND or COMMAND/DATA by an error), since there is no information available to the TAXI Receiver to indicate where the error lies. The user needs to be aware of this possible transposition (possible with all four types of VIOLATION), since the system must account for it. VIOLATION will always be the flag for these detectable errors.

This method of detection is not 100% effective. As Appendix B shows, it will detect approximately 50% of the possible double bit errors in Data. Double bit errors in Command will be detected 99.8% of the time or more, depending upon the pattern width. Appendix B contains a more detailed treatment of the efficiency of the violation logic for the various data bit modes.

The method of detecting violations, is effective enough to be used to give an early warning of transmission problems before the host's error detection system would detect the errors. It should not be used alone in fault sensitive systems, since it misses a significant number of transmission errors which cause one valid DATA pattern to alias to another VALID DATA PATTERN.

3.3 TAXI PLL Characteristics

The Phase Locked Loop in the TAXI Receiver is used to recover the data encoded in the serial bit stream sent by the TAXI Transmitter. In order to ensure accurate data recovery, the Receiver PLL must lock on to the underlying code rate of the Transmitter, and must track minor changes in frequency and phase while rejecting noise superimposed on the bit stream. This noise includes both amplitude and phase/frequency disturbances. Amplitude variations are dealt with in the Receiver's input amplifier (SERIN+/-), and are not passed through to the PLL, except for phase effects.

Phase/frequency noise, or jitter, can come from many sources, and can have many different characteristics. Jitter can be introduced by the Transmitter, the Receiver, the media interface or by the media itself. Examples of media induced jitter include reflections and edge perturbations caused by improper line termination, pulse width spreading due to frequency dependent cable attenuation, and pulse dispersion caused by fiber optic cable effects. Examples of media interface jitter include low light effects in optical receivers and pulse width distortion caused by baseline shift (changing DC offset) in AC coupled amplifiers.

The TAXI PLL has been optimized to allow correct data recovery in the presence of the largest jitter possible. To this end, the PLL parameters, most notably loop bandwidth, have been chosen to enhance the jitter tolerance of the TAXI Receiver.

This optimization is at the expense of lock-up time. In TAXI systems, lock-up time is relatively unimportant, since the system must achieve lock only during system power-up. If the PLL achieves proper lock within a few tens, or even hundreds of microseconds, its startup will be similar to the start-up characteristics of the system power supply.

The actual time to lock begins during power-up, when both Transmitter and Receiver are marginally powered and the entire link is marginally functional. Transient effects other than PLL characteristics, which typically occur during power-up, can either lengthen or shorten the apparent lock time. These effects are a function of actual implementation and are not discussed here. The discussion which follows assumes that both Transmitter and Receiver are fully powered, and that the link is fully operational. The only effects included are PLL transient effects.

If there is no data on the link (if the Transmitter is off, or if there is a quiet line) the data recovery PLL will drift to its natural oscillation frequency. This frequency is determined by component values and tolerances inside the Am7969 receive PLL, and will vary slightly from both the Receiver reference frequency (at X1 of the Receiver) and the Transmitter data frequency (X1 of the Transmitter).

When data appears on the line, the receive PLL must achieve phase lock from its resting frequency. The structure of the PLL used in the TAXIchip set ensures that this resting frequency will be no more than a few percent (typically less than 3%) from the reference frequency applied at X1. This is in addition to the specified Transmitter/Receiver frequency mismatch allowed by the crystal tolerance specification of +0.1%.

Figure 3-1 Calculated Receiver Lock-Up Time

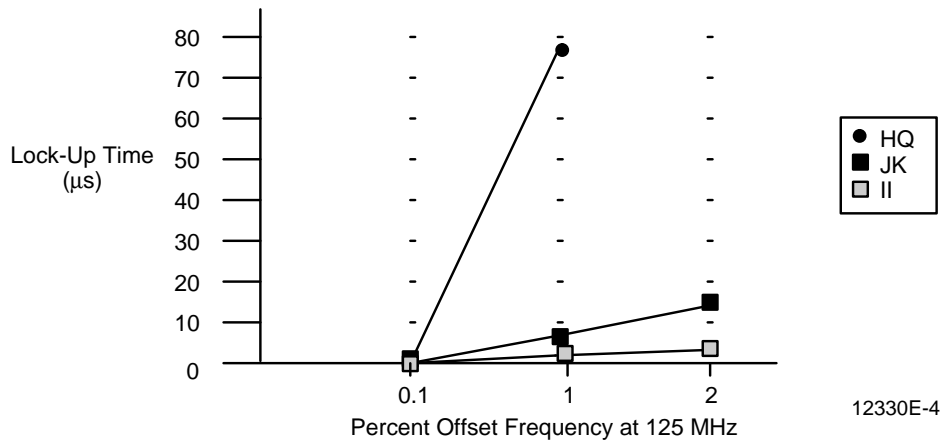

Neglecting frequency variations in the Transmitter and jitter in the data stream, the time to lock is related to the PLL loop bandwidth and damping factor, and to the transition density. The loop parameters are set by the internal component values and tolerance of the TAXIchip set. A plot of calculated lock-up time vs Transmitter to Receiver frequency offset and transition density is given in the Figure 3-1. Note that low transition density causes longer lock times. In fact, at very low transition densities (1 transition per 10 bit times of the HQ symbol), and large offset frequencies, the PLL may not be able to acquire lock at all, even though the lock equation used to produce the graph seems to indicate a solution. As the limits are approached, lock time may grow to several times the value predicted by the lock equation.

4.0 CLOCK GENERATION AND DISTRIBUTION

The serial baud rate for the Am7968 Transmitter is derived from a byte rate frequency source. The TAXI Receiver must run at the same frequency as the TAXI Transmitter. The relationship between serial baud rate and data byte rate depends on the width of the transmitted data. For 8-bit data, the byte rate is multiplied by 10 to obtain the serial clock rate. Since the maximum operating frequency is 125 MHz and the minimum frequency is 40 MHz, the byte rate frequency range for 8-bit data is between 4.0 and 12.5 MHz. The multipliers for 9 and 10 bit data widths are 11 and 12 respectively. The following table summarizes the byte rate frequency ranges for each data width selected.

Am7968/Am7969-125		
Data Width	PLL Multiplier	Byte Rate
8	10	4.00 – 12.50 MHz
9	11	3.64 – 11.36 MHz
10	2	3.33 – 10.42 MHz
Am7968/Am7969-175		
Data Width	PLL Multiplier	Byte Rate
8	10	12.5 – 17.5 MHz
9	11	11.37 – 15.90 MHz
10	12	10.42 – 14.58 MHz

The source of byte rate frequency can be either from the built-in crystal oscillator or from a TTL clock signal. The maximum allowable mismatch between Transmitter and Receiver frequency sources is $\pm 0.1\%$. This tolerance is derived from the PLL architecture in the TAXI Receiver, and from considerations of crystal accuracy. More information on crystal specifications and available distributors can be found in Appendix C, TAXI TIP #89-05, *TAXIchip set crystal specification*.

When there is no incoming data, the Receiver PLL has no serial data stream to track. This situation can arise if the Transmitter has not been powered up, or if the transmission medium is disconnected. In this case the VCO will drift to a frequency determined by internal component tolerances. When data appears at the Receiver serial input, the loop must acquire lock from this resting frequency. The worst case frequency offset and the capture range of the PLL are designed to allow frequency mis-matching between Transmitter and Receiver of $\pm 0.1\%$, since this accuracy is achievable with inexpensive available crystals.

4.1 TAXI Transmitter Clock Connections

The byte rate frequency source drives a multiplying PLL to create an internal bit rate clock which is used for timing all internal logic. The X1 and X2 pins are used to input the byte rate frequency source to the Transmitter. Their exact usage will vary, depending on type of frequency source (crystal or external TTL) and mode of TAXI Transmitter operation (Local or Test).

4.1.1 Local Mode Transmitters

In Local mode, X1 and X2 are the crystal oscillator inputs. The external component connections are shown in Figure 4-1. Zero temperature coefficient capacitors (type NPO) should be used for good temperature stability.

Typical Crystal Specification

Fundamental Frequency	4.0 MHz –17.5 MHz +0.1%
Resonant Mode	Parallel
Load Capacitor (Correlation)	30 pF
Operating Temperature Range	0°C to 70°C
Temperature Stability	±1.00 ppm
Drive Level (Correlation)	2 mW
Effective Series Resistance	25 Ω (max)
Holder Type	Low Profile
Aging for 10 Years	±10 ppm

Figure 4-1 TAXIchip Crystal Connection

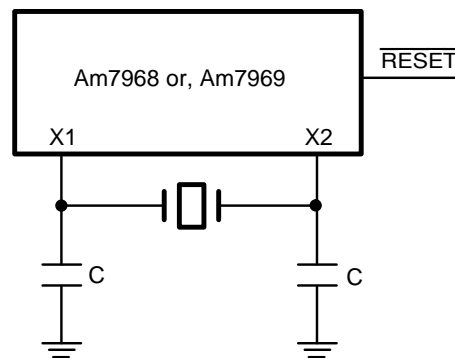

12330E-5

C = 150 pF for a 12.5 – 17.5 MHz Crystal, 220 pF for a 4 MHz–12.5 MHz Crystal

The Transmitter may also be run in local mode by applying a TTL frequency source to X1 and grounding X2. The TTL source may be either from a crystal oscillator module, or from a neighboring TAXI Transmitter CLK output. In local mode, CLK is the buffered output of the internal crystal oscillator. Connecting the CLK output of a TAXI Receiver directly to the X1 input of a TAXI Transmitter is not recommended, because the Transmitter's clock stability and jitter requirements are not satisfied by the Receiver CLK output.

4.2 TAXI Receiver Clock Connections

The considerations and connections for the TAXI Receiver are similar to those for the TAXI Transmitter. The Receiver X1 and X2 inputs connect to an on-chip oscillator, whose frequency is determined by a parallel resonant crystal, or is driven by an external TTL frequency source. The oscillator provides the reference, which sets the expected center frequency for the data synchronizing PLL. The synchronizing PLL tracks the incoming data and generates a bit clock from the serial data stream. All of the internal TAXI Receiver logic, including the logic that generates the CLK output, runs on this bit rate clock. This recovered clock is as stable as possible in both frequency and phase, as it tracks the incoming data stream. In addition to the bit synchronization accomplished by the PLL, the logic will maintain byte synchronization (framing) with the incoming data

using the Sync symbol to define byte boundaries. If the byte boundaries must be re-aligned (on power-up or re-acquisition of signal), the logic will ensure that the CLK is stretched (never shortened) upon re-sync to the new byte alignment. Due to this behavior, the CLK output from the Receiver is not suitable as a direct frequency reference for another TAXI Transmitter or Receiver. CLK is intended to be used by the host system as a clock synchronous with the received data.

Figure 4-2 Cascaded Receiver Clock Connections

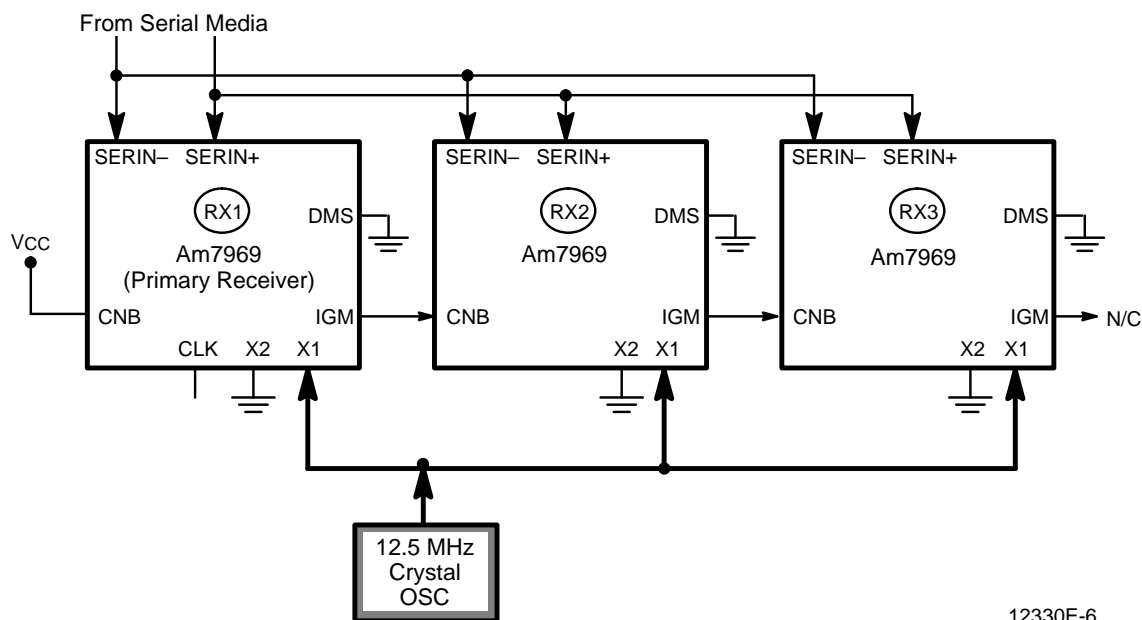

12330E-6

4.2.1 Cascade Mode Receivers (Am7969-125 Only)

When using an on-board TTL clock source, Receivers which are in Cascade mode should have their X1 pin tied to the Crystal Oscillator and their X2 pin grounded. Figure 4-2 shows a typical cascaded Receiver clock connection. The frequency source for the Local mode Receiver should be either a crystal oscillator (as shown) or another external TTL source. It should not be the CLK output of another Receiver. As discussed above, the CLK output from the Receiver is not suitable as a frequency source for other TAXI Receivers.

5.0 INTERFACING WITH THE SERIAL MEDIA

The Am7968/Am7969 TAXIchip set is capable of providing a high speed point-to-point serial link over fiber-optic, coaxial, or twisted pair media. The choice of the appropriate medium depends primarily on line length and data rate. This chapter discusses the issues involved in media choice and the requirements for driving different types of media.

Any TAXIchip set to media interface design must first take into account the electrical properties of the TAXI Transmitter and TAXI Receiver. The Transmitter serial output drivers are open emitter, emitter followers which generate pseudo-ECL (PECL) levels when terminated by pull-down resistors to a voltage more negative than V_{OL} . PECL is ECL referenced to the +5 V supply, so that $V_{OH} = (5-0.8)$ and $V_{OL} = (5-1.8)$ volts. A safe termination voltage which guarantees meeting V_{OL} is 3 V or less. The Receiver input is a long-tailed pair which will switch on 50 mV differential input voltage, with a large

common mode range. The average DC value of the input signal is therefore relatively unimportant.

There are three broad classes of TAXI-to-media interface:

1. Very short (<3" link length), usually DC coupled.
2. Terminated, DC coupled.
3. Terminated, AC coupled.

The short link is typical of a TAXIchip set to optical components connection. The terminated cases are used for driving cables, also optical or other components with incompatible power supply and/or logic level requirements may sometimes need circuits and layout that exceed 3".

5.1 Very Short Link, DC Coupled

For DC coupled inter-connections in which the distance between the serial pins and the next device is less than 3", transmission line terminations are not necessary. All that is required is an appropriate PECL pull-down resistor, RE. Elimination of reflections is not required for these short line lengths because the round-trip propagation is significantly less than the 2 ns TAXIchip set rise and fall time. The effect of media mismatch in this case is distortion and slowing of the transition due to the addition of the reflection to the still changing edge.

Figure 5-1a Standard Load Circuit

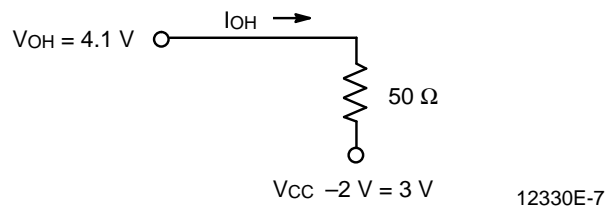
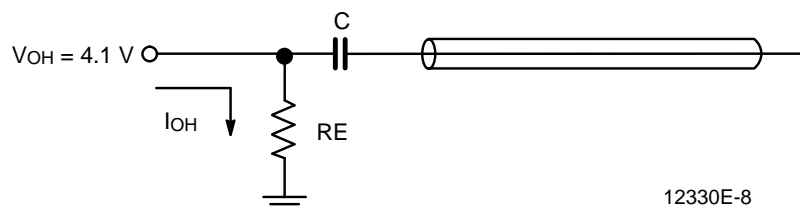

Figure 5-1b Pull-Down with IOH Matched to Standard Load



The lower limit for RE is that value which produces the maximum value of IOH. In a standard PECL load circuit (Figure 5-1a) IOH max is given by:

$$(V_{OH} - (V_{CC} - 2))/50 = (4.1 - 3)/50 = 22 \text{ mA}$$

If we return RE to ground instead of 3 V (Figure 5-1b), the minimum value of RE becomes 4.1 V/22 mA, or 186 Ω.

Reflections due to mismatch can be minimized by locating the pull-down resistor at the end of the line, rather than the source. A mismatched line termination will give a reflection coefficient less than one while leaving the end of the line open will give a reflection coefficient of one (maximum reflection). Note that the supply voltage and logic

level of the optical components must match those of the TAXIchip set in order for the DC connection to work. If the supply voltage or the logic levels are incompatible, an AC connection must be used.

5.2 Terminated, DC Coupled

The parallel termination shown in Figure 5-2 may be used for a DC connection of a TAXI Transmitter to a TAXI Receiver. The parallel termination provides both the line termination ($R1 \parallel R2 = Z_0 =$ line characteristic impedance) and a pull-down voltage. The Thévenin equivalent of this termination is Z_0 pulled down to $V_{CC} - 2V$, assuring both matched termination and adequate V_{OL} . Using V_{CC} and a voltage divider provides pull-down voltage without the need for a separate power supply.

Figure 5-2 Parallel Termination

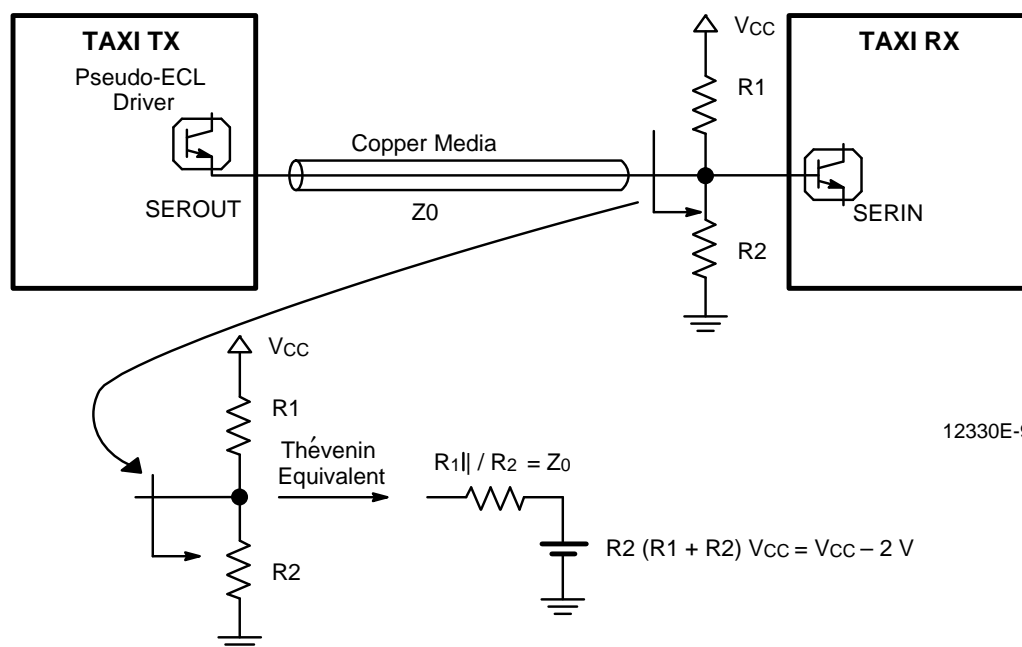

5.3 Terminated, AC Coupled

AC coupling is the connection of choice for many TAXIchip set applications. The typical arrangement for an AC coupled link is shown in Figure 5-3. RE is returned to ground to provide the PECL (pseudo-ECL) pull-down for the driver. The capacitor C blocks the DC voltage, and R1 and R2 terminate the transmission line and provide a DC bias level for the Receiver. Since only AC variations are passed through the coupling capacitor, the bias level at the termination should be set to the midpoint of the signal swing expected by the Receiver input stage. Note that this bias level is not the same as that which is recommended for the DC coupled case.

The minimum value of RE was previously established as 186 Ω , to avoid exceeding $I_{OH\ max}$. The maximum value of RE must be small enough to supply the transmission line with enough current to avoid cutting off the output driver. When switching from a HIGH to the LOW state, the transmission line may cause the emitter voltage of the driver to fall more slowly than the base voltage, causing the output transistor to turn off. When the output transistor turns off, its output impedance becomes very high, causing the falling edge rate to be controlled by the external load (RE and the transmission line). This variation in edge rate cannot be tolerated until the falling edge crosses the

threshold level of the receiver's differential amplifier. Once the Receiver recognizes the state change, variations in the falling edge are not significant.

To avoid edge rate variations due to driver turn-off, we must equate the voltage to which the driver is taken at turn-off with a point in the logic swing which will guarantee that the Receiver changes state. Since PECL logic swings are 800 mV, we may safely choose a 500 mV change at the driver (100 mV past the midpoint) as a guaranteed state change at the Receiver. If the driver turns off instantly, we require the voltage divider formed by RE and Z0 to produce a 500 mV change from VOH. We can write:

$$V_{OH} RE / (RE + Z_0) = V_{OH} - 0.5$$

$$4.1 \times RE / (RE + Z_0) = 3.6$$

$$RE = 7.33 Z_0$$

As a general rule, we may then say that:

$$186 < RE < 7.33 Z_0$$

Figure 5-3 Pull-Down and Termination for AC Coupled Link

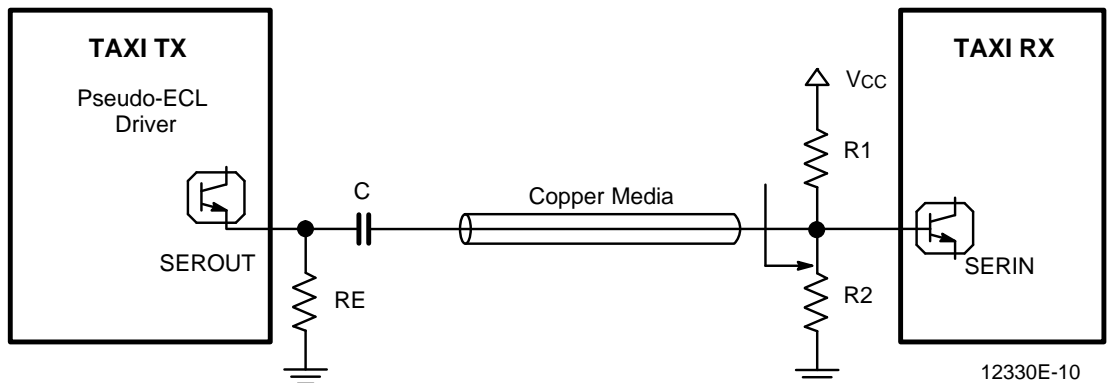
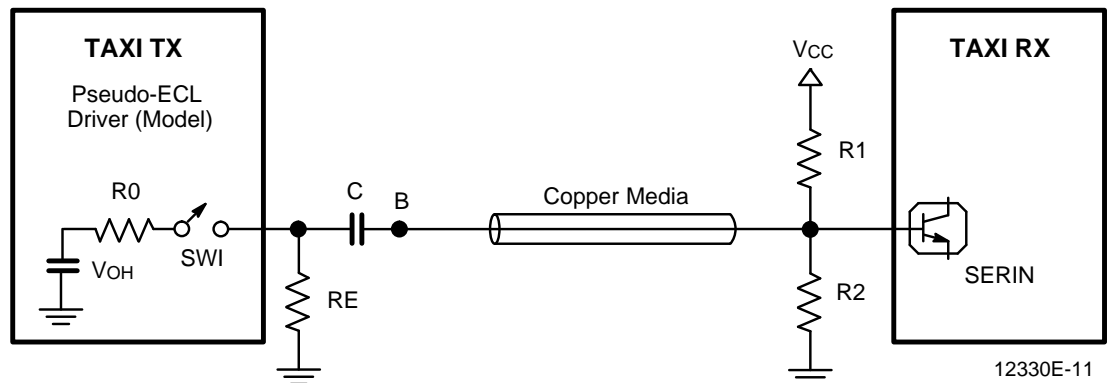

Figure 5-4 Serial Link with Output Driver Model



5.4 Baseline Wander and the AC Coupling Capacitor

The 4B/5B and 5B/6B data encoding schemes which are used by the TAXIchip set are run-length limited to a maximum of 3 consecutive LOW states (non-transitions in NRZI). This type of encoding ensures that on average there will be less than $\pm 10\%$ variation in the DC component of the encoded data.

When the encoded data is passed through an AC coupled link, the high-pass filtering of the AC coupling will introduce jitter because of the fluctuating threshold caused by the variation in DC component. This undesired side-effect of AC coupling is often described

as baseline wander effect and is illustrated in Figure 5-5. In Figure 5-5a, the average DC fluctuates between 40% and 60% of the maximum level (+10% of midpoint). After the signal is capacitively coupled (Figure 5-5b), the average DC component is lost due to high-pass filtering, causing an undesired shift in the signal levels. This shift in the signal levels, coupled with non-zero rise and fall times of the serial stream cause pulse width distortion and thus apparent jitter and possible increased error rates.

This DC shifting effect can be minimized if the values of the AC coupling components are chosen appropriately. The DC level of the data will fluctuate at a data-dependent frequency, f_b , called the baseline wander frequency. The 3 dB corner frequency of the AC coupling, $f_{3dB}=1/(2\pi RC)$, should be chosen below the minimum baseline wander frequency of the data. This allows most DC variations to pass through the AC coupling high-pass filtering, minimizing the DC shift in the signal.

To minimize f_{3dB} we must maximize R and C. The resistance R is generally determined either by the termination required by the transmission line or by biasing requirements on both sides of the link. Hence, only the coupling capacitor C can be maximized to keep f_{3dB} as low as possible. The largest value capacitor that can be used is limited by the fact that it must be an RF capacitor. RF capacitors are generally of the ceramic type (NPO and X7R dielectrics) and are limited to a maximum value of approximately 1.0 μF . 0.1 μF capacitors have proven to be sufficient in laboratory tests of TAXIchip set systems.

For a 0.1 μF capacitor, we must verify that the capacitive reactance at the lowest fundamental frequency possible is less than 1 Ω . The lowest fundamental frequency possible is the frequency that results when the TAXIchip set is running at it's lowest BAUD rate (40 Mbaud) and the command or data pattern with the least number of transitions is being sent. This pattern turns out to be the HQ command (FDDI terminology) which has only 1 transition per command, or 1 transition per 10 bits when the command is encoded. If a continuous stream of HQ commands are sent at 40 Mbaud, the resultant fundamental frequency of the signal is 2 MHz. At 2 MHz, the capacitive reactance of a 0.1 μF capacitor is calculated as follows:

$$XC = \frac{1}{2\pi fC} = \frac{1}{2\pi (2*10^6) (0.1*10^{-6})} = 0.8 \Omega$$

Hence, in the worst case a 0.1 μF capacitor will give a reactance of less than 1 Ω , as desired.

In summary, the largest value RF capacitor available should be used to optimize the performance of the TAXIchip link.

Figure 5-5 Baseline Wander

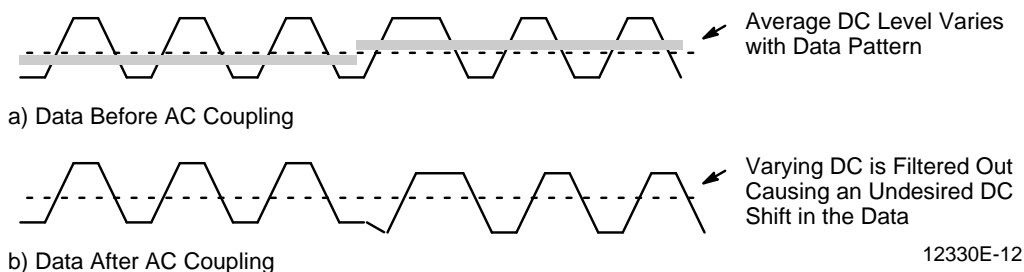

5.5 Interfacing to Fiber Optic Transmitters/Receivers

The TAXIchip set can be used in conjunction with optical components and optical fiber to form a simple fiber optic communication link. Optical transmission has many advantages over conventional electrical transmission. These include: immunity to EMI/RFI, low attenuation, electrical isolation, data security, and wide bandwidth. Because of these features, use of optical fiber as the serial media will result in optimum performance of the TAXIchip set link. Depending on the type of fiber and the optical components used, TAXI links using optical fiber can cover distances of up to several kilometers.

Figure 5-6 shows a block diagram of a complete TAXI fiber optic link. The optical components transmitters and receivers can be obtained from one of the sources listed in Appendix A of this manual. The interface between the TAXIchips and the optical components will be the subject of this section.

Figure 5-6 TAXI-Based Fiber Optic Link

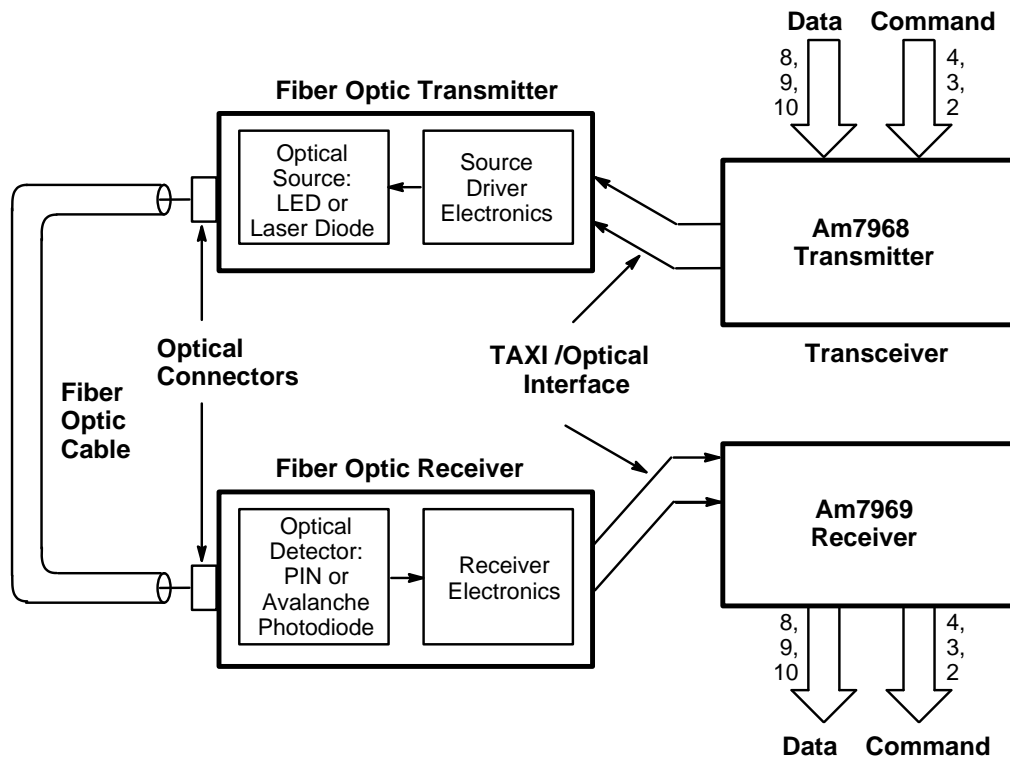

12330E-13

5.5.1 DC-Coupled TAXI-Fiber Optic Transceiver Interface

When passing data between the TAXIchip set and an optical module, care must be taken to assure that the logic levels of the TAXIchip set and the optical components are matched. If the supply voltages of the optical components do not match those of the TAXIchip set, then the logic levels will probably differ and the interface will require AC coupling to isolate these different levels. However, if the power supply requirements match those of the TAXIchip set (i.e. $V_{CC} = +5\text{ V}$, $V_{EE} = \text{GND}$) and if the two components are connected to the same power and ground planes, a DC coupled interconnection may be sufficient.

For DC-coupled interconnections in which the distance between the TAXIchip set and the optical module is less than 3", transmission line terminations are not necessary. All that is required is the appropriate ECL pull-down as shown in Figure 5-7⁽¹⁾. On these short line lengths, elimination of line reflections is not critical. However, without any increase in complexity or power consumption, line reflections can be reduced simply by locating the pull-down resistor, R_E , at the end of the line instead of at the beginning. This reduces the reflection coefficient at the end of the line, and therefore, reducing the magnitude of the reflections.

Figure 5-7 DC-Coupled TAXI-Fiber Optic Interface (Unterminated)

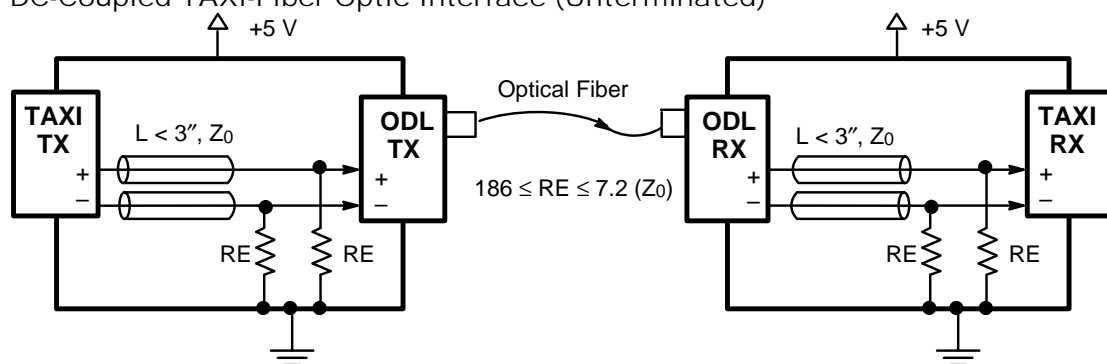

Note:

If the DC-coupled interconnection is longer than 3", transmission line terminations are necessary. For this case, the suggested configuration is shown in Figure 5-8. Note that the line termination network also provides the desired pull-down to $V_{CC} - 2V$, sufficiently below the output LOW level of $V_{CC} - 1.8V$

12330E-14

Figure 5-8 DC-Coupled TAXI-Fiber Optic Interface

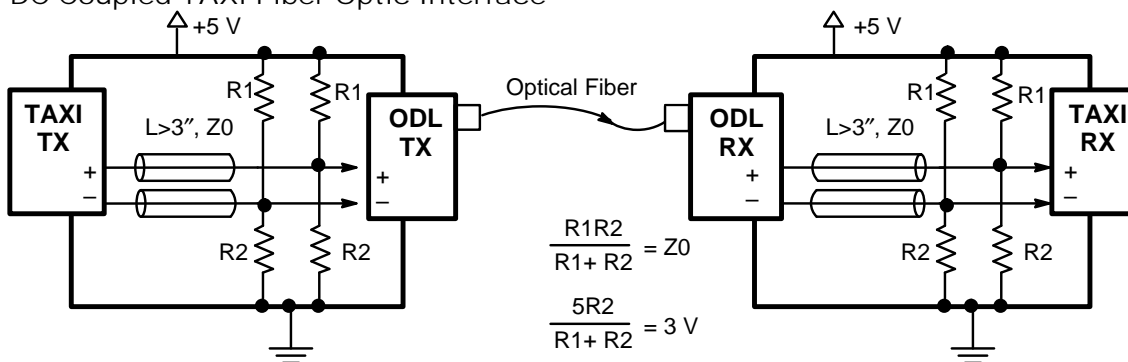

Note:

If the optical and TAXI power and ground planes are decoupled as shown in Chapter 6, AC coupling is always recommended to allow for variations in power and ground plane voltages. AC coupling is discussed in Section 5.5.2.

12330E-15

⁽¹⁾ Adequate bypass capacitors have been omitted from this and the following figures to simplify the drawings.

5.5.2 AC-Coupled TAXI-Fiber Optic Transceiver Interface

Some applications will require the TAXIchip set to optical transceiver interconnection to be AC-coupled. AC coupling should be used in the following situations: a) when the TAXIchip set and optical components are driven by a common power supply but the supply pins are decoupled using the scheme recommended in Chapter 6, and b) when the TAXIchip set and optical components operate on different power supplies.

AC coupling via capacitors along with the necessary design equations is shown in Figure 5-9. In this configuration, RE is the ECL output pull-down resistor, C provides the AC coupling, the connection is made with a transmission line (coax, twisted pair, microstrip) of length L and characteristic impedance, Z0, and R1 and R2 provide a matched line termination and voltage bias to the midpoint of the optical component's logic swing (V_{bb}).

The configuration shown in Figure 5-9 is recommended for any line length, L, which separates the TAXIchip set and the optical module. Although the matched line termination is not necessary for L < 3", the V_{bb} bias voltage is always needed for AC-coupled links. Therefore, even for line lengths where matched line terminations are not necessary (less than 3"), the resistors R1 and R2 can be chosen to give a matched load without any added complexity.

Figure 5-9 AC-Coupled TAXI-Fiber Optical Interface

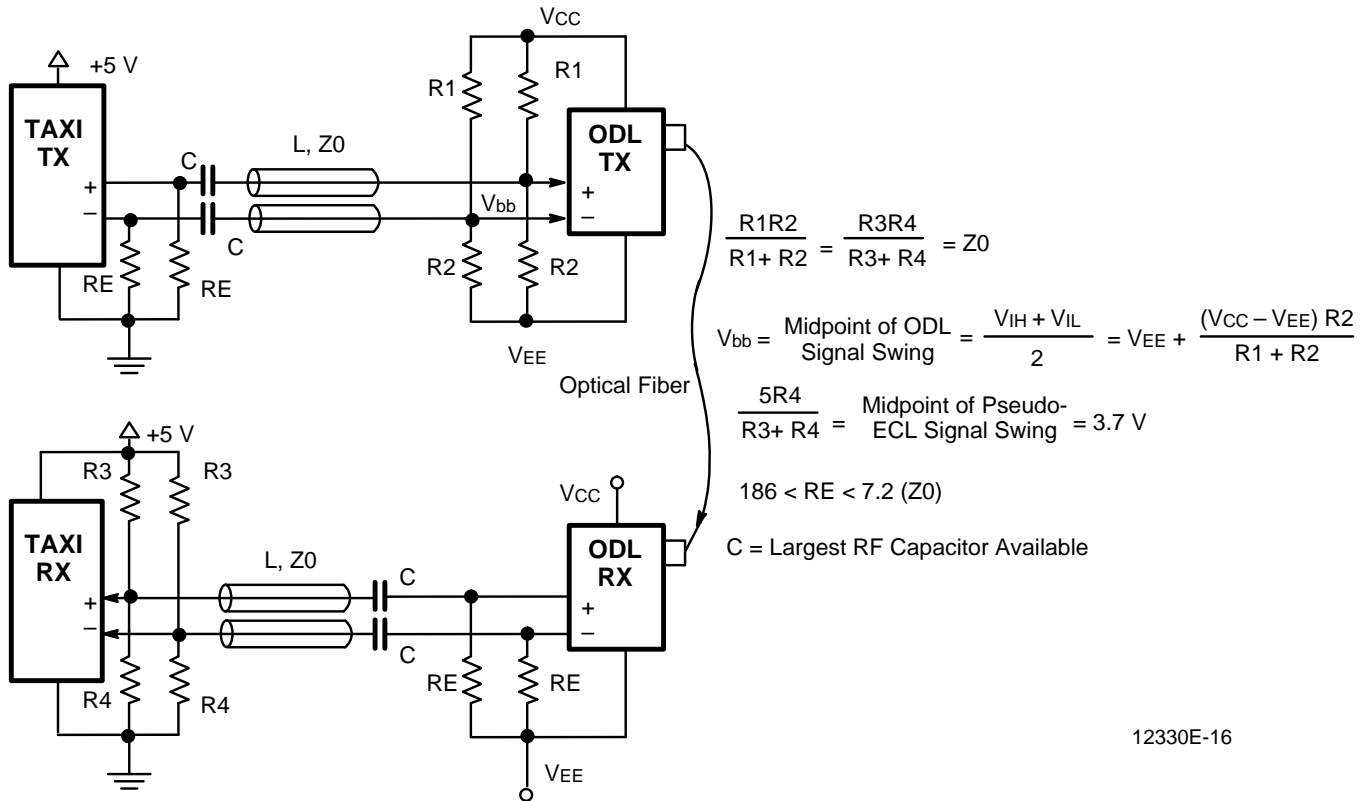

12330E-16

5.6 Interfacing to Coaxial Cable

In many applications, system cost can be reduced by using coaxial cable as the serial media. Unlike optical fiber, which requires optical components between the fiber and the TAXIchip set, coaxial cable can be connected directly to the TAXI SEROUT pins, giving lower system costs.

Because of the resultant lower system costs, coaxial cable is the recommended serial medium for short-to-moderate length links. At longer lengths, the advantages of fiber optic transmission (low attenuation, immunity to EMI and ground loops, etc.) make it the media of choice.

The maximum length possible for a coaxial cable TAXI link depends on the type of coaxial cable used and the data rate. Higher data rates will tend to limit link lengths because attenuation and pulse dispersion on coaxial cable increases with frequency. Many different types of coaxial cables are available. Some have far less attenuation than others however, with low loss generally comes increased size and rigidity.

RG-58 is a commonly used, readily available type of coaxial cable. In lab tests using this type of cable, it was found that the TAXIchip link could operate with a byte error rate of better than 10^{-10} with a *confidence limit* of 95%, at byte rates of up to 12.5 MHz, at distances of up to 200 feet. The *confidence limit* accounts for the statistical nature in which errors occur in a digital system and it implies that we can be 95% sure that, under the given circumstances, the byte error rate will be 10^{-10} or better. Note that a byte error could have been due to a single bit error or more hence, the bit error rate may not be equal to the byte error rate divided by ten.

Using the TAXIchip set in conjunction with coaxial cable as the serial media is quite simple. Appropriate line terminations are required and AC coupling is strongly recommended to eliminate ground loops. The recommended configuration, including the necessary design equations, is shown in Figure 5-10. Each of the components that make up the interface serve the same purpose as in the AC-coupled TAXI-fiber optic interface shown in Figure 5-9.

Note that two coaxial cables comprise the link, one for each of the differential pseudo ECL signals. These two lines should be calibrated for a propagation delay difference of less than 0.2 ns.

Figure 5-10 Coaxial Cable Interface

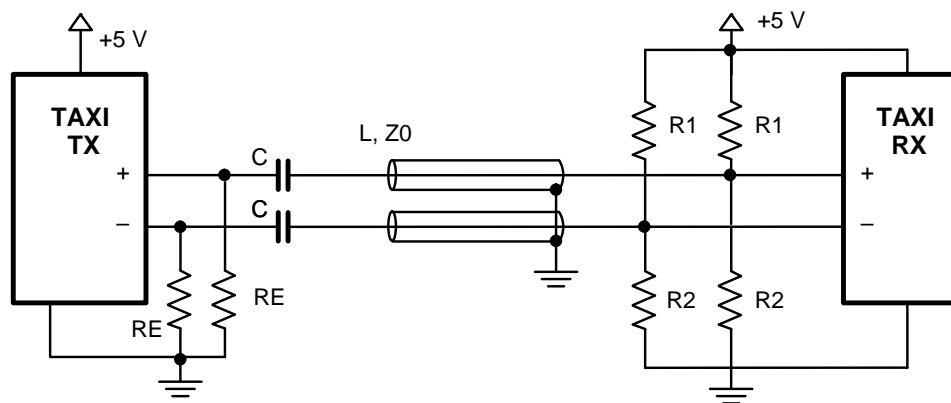

$$\frac{R1R2}{R1+R2} = Z0$$

$$\frac{5R2}{R1+R2} = \text{Midpoint of Pseudo-ECL Signal Swing} = 3.7$$

$$186 \leq RE \leq 7.2 (Z0)$$

C = Largest RF Capacitor Available

12330E-17

Sample Values

Using RG-58A/U, 50 Ω coaxial cable, a successful TAXI link was established using the following component values:

- R1 = 68 Ω
- R2 = 200 Ω
- RE = 300 Ω
- C = 0.1 μF

5.7 Interfacing to Twisted-Pair Cable

Another low cost alternative twisted pair cable. Twisted pair cable is generally more lossy than coaxial cable making it suitable only for short distances. To reduce the possibility of noise being induced along the line, the shielded twisted-pair cable is recommended.

Using the TAXIchip set with shielded-twisted-pair as the serial medium is very similar to using it with coaxial cable. The recommended configuration is shown in Figure 5-11, where each of the components that make up the interface serve the same purpose as in the AC-coupled TAXI-fiber optic interface shown in Figure 5-9.

Note that with shielded-twisted-pair, only one cable is required to form the link. The twisted-pair conductors carry the differential pseudo-ECL signals and the shield is grounded at the Receiver.

Figure 5-11 Shielded-Twisted Pair Cable Interface

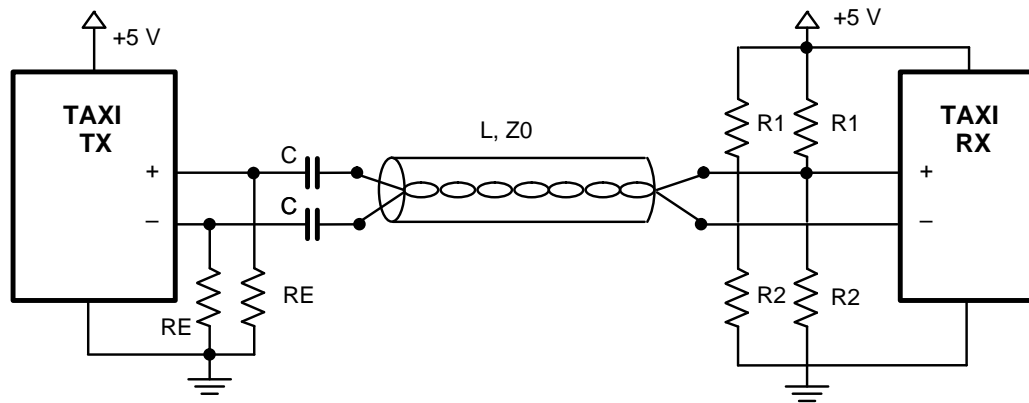

$$\frac{R1R2}{R1+R2} = Z0/2$$

$$\frac{5R2}{R1+R2} = \frac{\text{Midpoint of Pseudo ECL Signal Swing}}{=} = 3.7 \text{ V}$$

$$186 \leq RE \leq 7.2 (Z0)$$

C = Largest RF Capacitor Available

12330E-18

Sample Values

Using IBM Type 1 STP 150 Ω shielded twisted pair cable, a successful TAXI link was established using the following component values:

$$R1 = 101 \Omega$$

$$R2 = 291 \Omega$$

$$R3 = 300 \Omega$$

$$C = 0.1 \mu\text{F}$$

6.0 BOARD LAYOUT CONSIDERATIONS

While the TAXIchip devices are digital in application, they are essentially analog parts, containing high frequency analog Phase Locked Loops. Reliable operation in a high frequency analog and digital environment requires that some simple board layout rules be followed.

For example, most TAXI applications which are laid out on a wire wrap board will not work reliably. Because they have at most one power and ground plane, most wirewrap cards have insufficient separation between small signal current and digital switching current. Digital switching noise can couple into the analog PLL, causing phase errors and loss of synchronization. The preferred realization of a TAXI application is on a printed circuit board, where the user can control the layout of power and ground planes.

6.1 Printed Circuit Board Layout

6.1.1 Rules for Layout

The following rules should be followed to ensure minimal noise coupling:

1. Use a PC board with separate GND and V_{CC} planes.
2. Use two capacitors which differ by at least a factor of ten in value to decouple the devices. The reactance of large capacitors has a significant inductive component at high frequencies. Because of this inductive component, a single large capacitor is not very effective against high frequency noise. Two capacitors, one typically of 1 μF and one of 0.1 μF are more efficient at decoupling than a single large capacitor of 1.1 μF . The recommended layout is as shown in Figure 6-1.

Figure 6-1 Transmitter and Receiver Decoupling Layouts

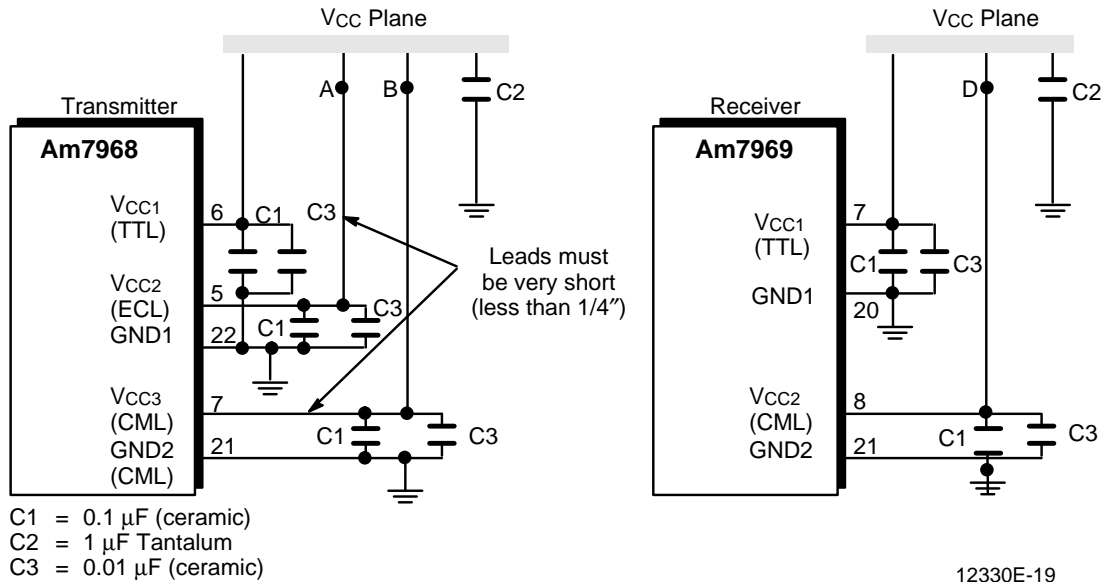

To further decouple the TAXI chip set, it is highly recommended that ferrite beads be inserted at locations A, B and D.

Figure 6-3 Jogs and Glitches in the Clock Line

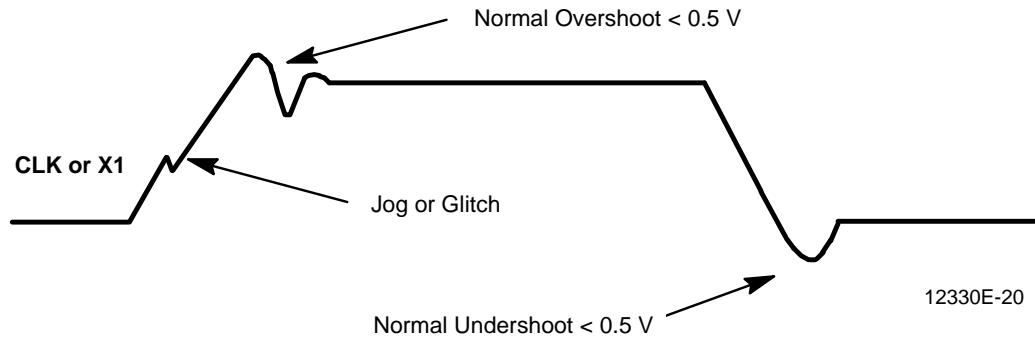

3. Keep all bypass capacitors as close to the power pins of the device as possible. Lead lengths should be minimized.
4. Use high quality RF grade capacitors such as type COG or X7R. Use of Z5U capacitors is not recommended.
5. Ensure that the power supply does not have more than 100 mV of peak-to-peak noise at any of the TAXI Vcc pins. Make this check while the TAXIs are sending random data.
6. While CLK can drive four X1 inputs or several TTL loads, the highest performance can be achieved by reducing the load on the CLK pin. Care should be taken to ensure that no jogs or glitches occur in the CLK signal as shown in Figure 6-3. If present, these glitches will be passed onto the PLL and cause an occasional error.

Serial Lines

7. Run serial outputs parallel to each other, or one on top of the other at all times and route them away from the Transmitter. Do the same for serial inputs on the Receiver. Running these serial traces adjacently will minimize noise caused by these extremely fast signals on other traces. Use of strip lines for serial signals is recommended.

- When terminating serial lines to or from the TAXIs ensure that the Vcc rail or ground tap is not at a noisy location. Resistors can couple noise from a power supply rail into the Serial lines. Vcc to Ground decoupling adjacent to the resistors is recommended when using pullup/pulldown terminating resistor setups as shown in Figure 6-4. When using only a pulldown, do not use decoupling as this could add more Vcc noise into the serial signals.

Figure 6-4 Decoupling Terminations

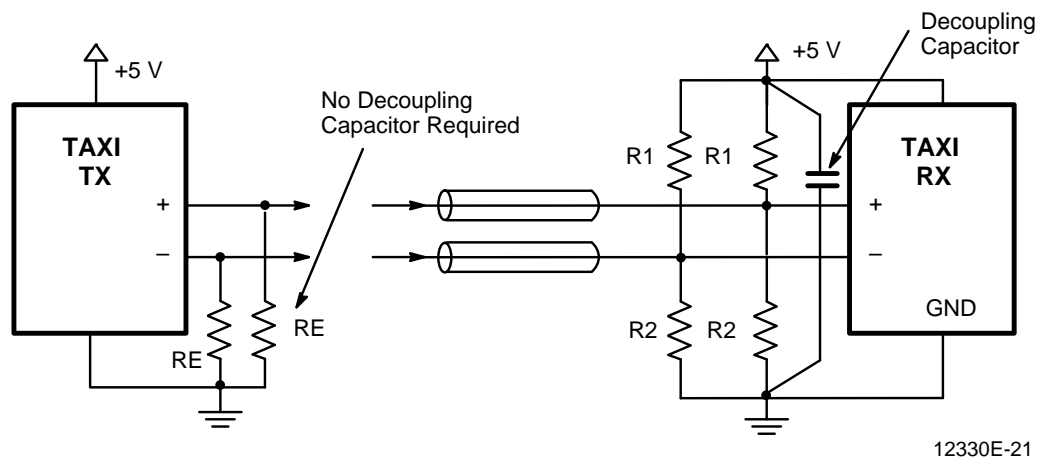

6.2 Layout using Fiber Optic Data Links

Because of their small signal levels, fiber optic data links require some care in layout. Fiber optic data Link receivers consist of a photo sensitive diode and an amplifier. The photo-diode converts light pulses into currents of around a few hundred nano-amps. This signal current is then amplified and translated into an ECL signal.

TAXI Receivers and most digital chips switch hundreds of milliamps. If switching noise from the digital section of the board gets coupled into the optical data link, the signal from the light pulse data can be corrupted. To prevent the coupling of the optical data link output with other digital signals, the user must ensure that small signal and digital switching currents do not flow in the same path. This is done by separating both the optical Vcc plane and the optical ground plane from the Vcc and Ground planes used by other digital circuitry. See Figure 6-5.

Figure 6-5 Fiber Optic Data Link Decoupling

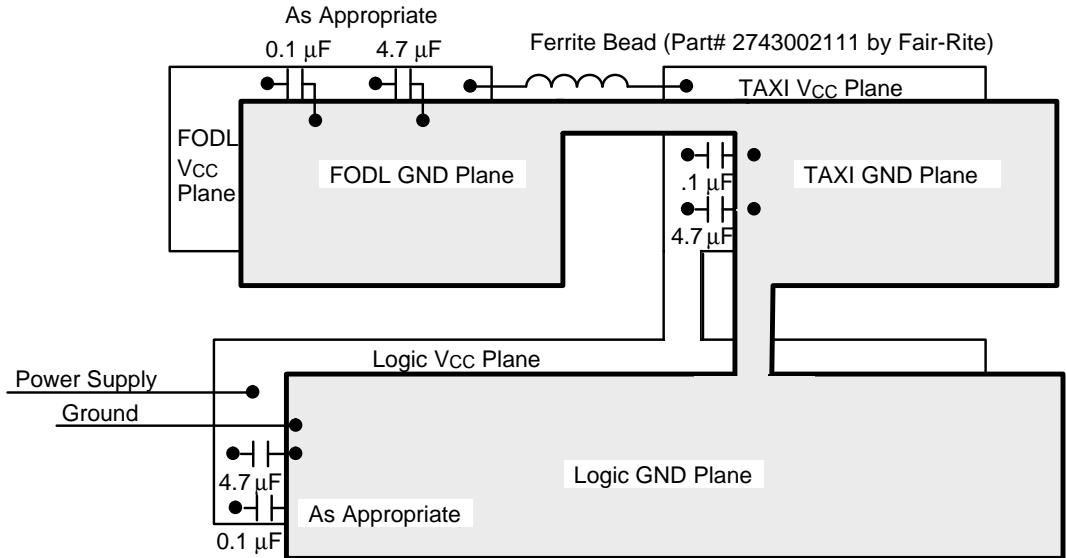

12330E-22

Note: This connection includes a ferrite bead in the VCC circuit of the fiber optic components.

7.0 CASCADE MODE OPERATION

The TAXIchip set can be cascaded to send multiple byte words over a single serial channel. Cascade operation is the loading of n bytes of data into a TAXI Transmitter, and the serial transmission of that data through the Transmitter to the media. Data and Command bytes are multiplexed into the Local Mode transmitter. Detailed block diagram and explanation of the data multiplexing method are described in section 7.1. Also see Appendix C, TAXI TIP #14.

For Am7969-125 TAXI Receivers, the connection is parallel for data and daisy-chained for control. That is, the SERIN pins of all TAXI receivers are connected together and to the media. The daisy chain of IGM to CNB control signals determines which Receiver latches which incoming byte. The Receiver whose CNB input is connected to +5 V is the primary Receiver, supplying the initial IGM, as well as a reference frequency for the X1 inputs of the down stream TAXI receivers.

Cascade mode does not increase data rate or throughput. The maximum data rate is 100 Mbits per second, cascaded⁽²⁾ or not. The advantage of cascading lies in the fact that the width of the data word is transparently maintained. If the application requires the transfer of 32 bits of data, Cascade mode allows TAXI transmitters to latch all the data, and send it over a single serial channel, and receive the data in proper order in four TAXI receivers at the other end of the link.

Another advantage of cascade mode is that if a byte gets corrupted, the system can be reset by just sending a Sync, ensuring that the first TAXI Receiver gets the first byte, the second Receiver gets the second byte, and so on. Performing this reset operation with latches would require additional logic to decode a Sync command which in turn would reset all the latches.

For Am7969-175 TAXI Receivers, see Appendix C TAXI TIP #13 for single receiver cascade operation.

⁽¹⁾Actually, in Non Auto-Repeat Cascade Mode, the throughput is less than 100 Mbits/s due to the need to send Syncs.

Figure 7-1 Cascaded TAXI System

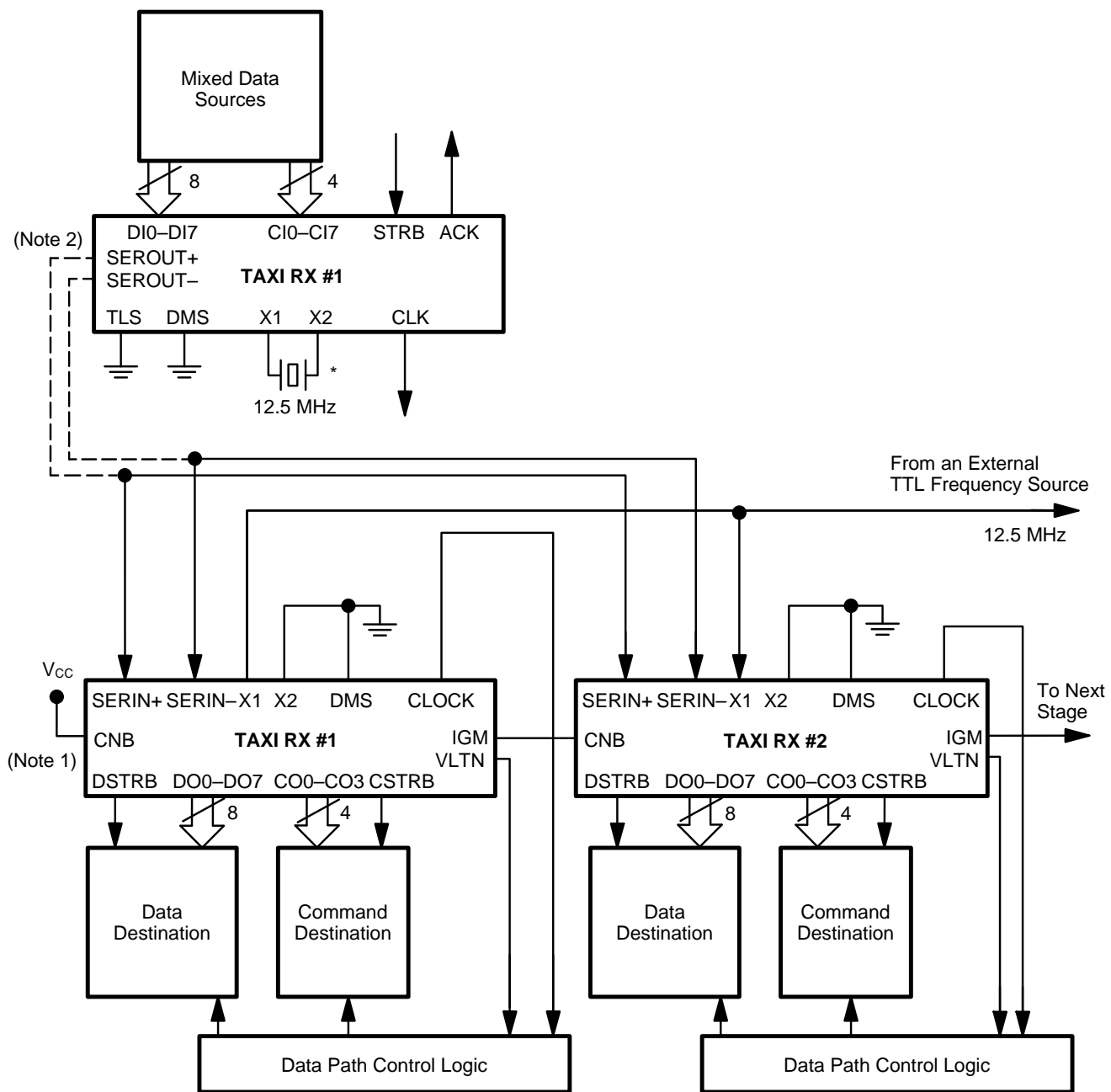

12330E-1

7.1 Transmit Cascaded Data with a Single TAXI Transmitter

For systems that require data transfer wider than a single byte, a single TAXI Transmitter can be used to cascade the multiple bytes. This operation allows the data to be multiplexed onto a single serial link, and then automatically demultiplexed and restored to the original word width. The TAXI Receiver performs this demux operation automatically when connected in the cascade configuration illustrated in the TAXIchip data sheet and section 7.2.

The circuit shown in Figure 7-2 illustrates the basic technique that may be used to control multiplexing of word-wide data into a single TAXI Transmitter.

This circuit assumes that the data to be transmitted is stored in appropriate registers that are all loaded simultaneously. While many systems will already include these storage elements, in the diagram these registers are shown as 74ALS374 octal D flipflops. They could be any register with the appropriate number of bits for the data, and a three-state controllable output. The registers are connected in a *TRISTATE MUX* configuration wherein each output can be selected individually.

To clarify the illustration of the technique, the Command lines are not used, and have been tied low. In systems that send Commands as part of the data stream, these lines would be buffered in the same way as the data, except that the unused bits (or bytes) need to be held low when Data is to be sent.

The *controller* for the automatic multiplexer consists of a shift register that can be loaded with a 0 that shifts through and selects each data register in sequence, and strobes the TAXI Transmitter. In the attached figure, this shift register is a 74LS174, but any collection of flip-flops would serve as well. The shifter is loaded with a 0 when STROBE, the signal that loads data into the registers, is a 1. The NAND gate (U1) at the input of the first flip-flop assures that only a single 0 is possible while the registers are being selected.

STRB for the Transmitter is derived from the CLK output of Transmitter, and is gated by the same signals that select the data. It is important that no *glitches* appear on the TAXI STRB input, since that will cause false data to be sent, and will disrupt the information transfer. To assure that any *race*-caused glitches appearing at the output of the four input NAND gate (U2) are suppressed, the counter must be clocked on the falling edge of the CLK. This assures that, during the time the outputs are changing, the *low* on the CLK input of the two input NAND gate (U3) will suppress anything happening on the other input. When CLK rises, it will be the only signal active, and there should be no false strobes. This configuration also assures the longest possible setup time for the output of the data registers, since the STRB happens immediately before the outputs change, and a full byte time before they change again. The other gates (U4, U5, U6) are only buffer and inverters used to assure proper signal sense, and fanout. They may not be needed in all systems.

Only four stages of shift register are required to select the four data registers, and the fifth stage shown in the figure is used to provide the SYNC character required for some cascade systems. The output of the fifth stage (ACK1 stands for one SYNC) is used to ACK systems that require a SYNC between data words. The output of the fourth stage (ACK0 stands for no SYNC) can be used for ACK in systems that expect to send contiguous data, and no SYNCs between words (auto-repeat cascade). Either of these outputs can be connected back to the DATA STRB input if the system is to run automatically, as in data sampling systems.

Figure 7-2 Cascade with One TAXI Transmitter

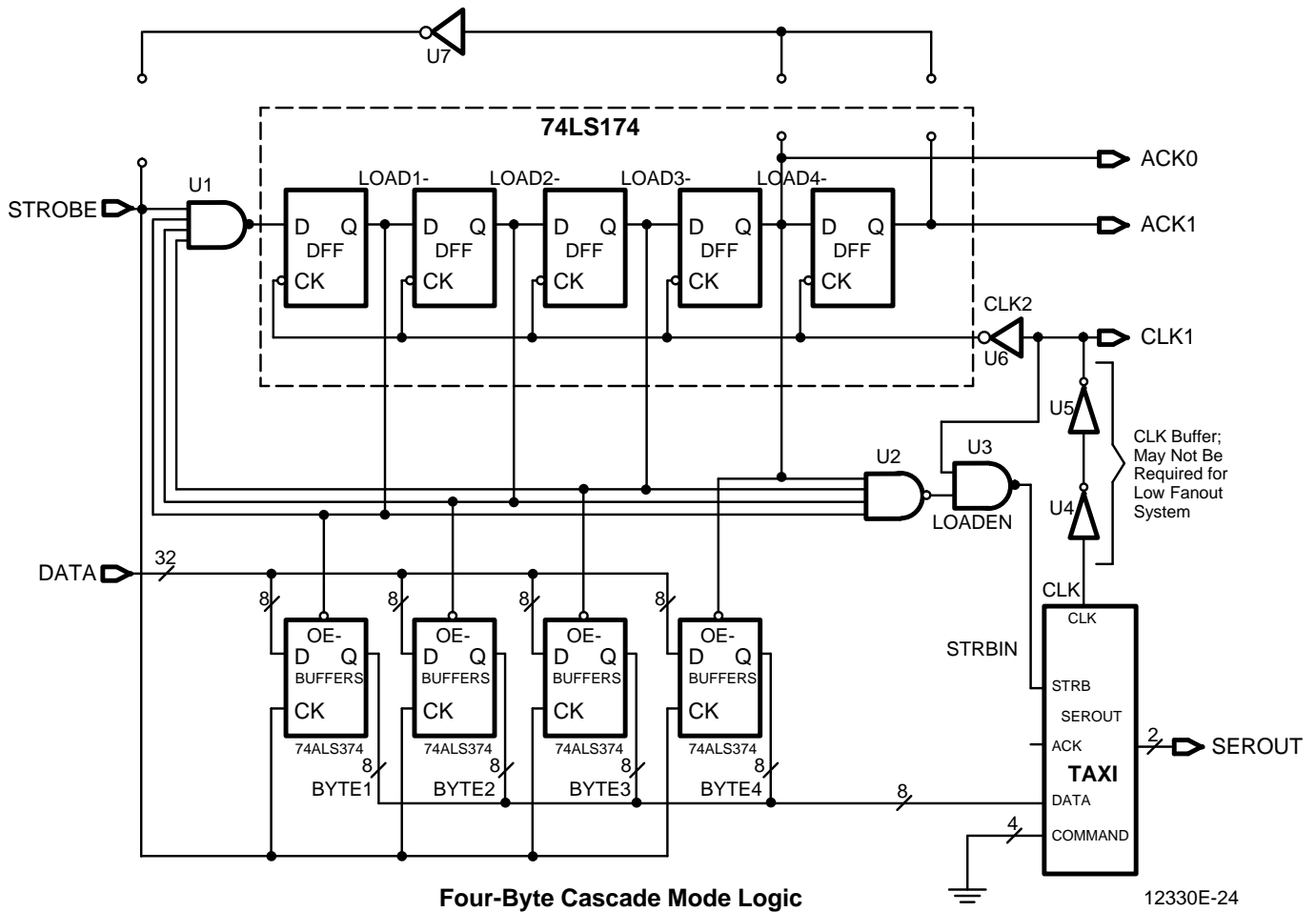

7.2 Receivers In Cascade Mode: Connections (Am7969-125 Only)

Unlike transmitters, all cascaded receivers are directly connected to the media, via the two serial input data lines. All Receivers see the same serial data at the same time. The Primary Receiver always receives the first byte of serial data after a Sync. The signals used by the upstream Receiver to tell the downstream Receiver that it has captured a byte are IGM (I Got Mine) and CNB (Catch Next Byte). After receiving its byte, the upstream receiver raises its IGM signal, telling the next Receiver in line that it is to catch the next byte on the serial line. In this way each succeeding Receiver down the line catches each succeeding byte.

The second receiver waits for the Primary Receiver to capture data before capturing its data (the second byte). Similarly, if there were a third Receiver it would wait until the second Receiver had captured the second byte before capturing the third byte.

The connections of the cascaded (downstream) TAXI Receivers are as follows (see Figure 7-3):

The CNB input of the cascaded Receiver is tied to the IGM of it's upstream neighbor. The CNB input of the first upstream or primary Receiver is tied high.

The IGM output of the last downstream Receiver is left unconnected normally. (This pin is used differently in Auto-repeat Configuration, discussed in section 7.3).

X1 is connected to a common Crystal Oscillator or a TTL Clock Source. It is not recommended that X1 be connected to another Receiver's CLK output.

X2 is grounded.

The DMS pins of all TAXIs must be tied in the same state as the DMS pins on the Transmitters.

The CSTRB/DSTRB pins on each of the Receivers are all active simultaneously. A timing description for CSTRB and DSTRB is included in Appendix C, TAXI TIP #89-10 *TAXI receiver CSTRB and DSTRB pulse width*.

The VLTN pin has timing that is identical to the timing of the Data Out and the Command Out lines. Its connections are specific to each user's applications.

If CNB is HIGH, the Receiver will catch the next valid byte of data and hold it. It will not attempt to catch any more data until it sees a Sync command from the Transmitter or until its CNB goes LOW and then HIGH again.

Figure 7-3 Receivers in Cascade Mode

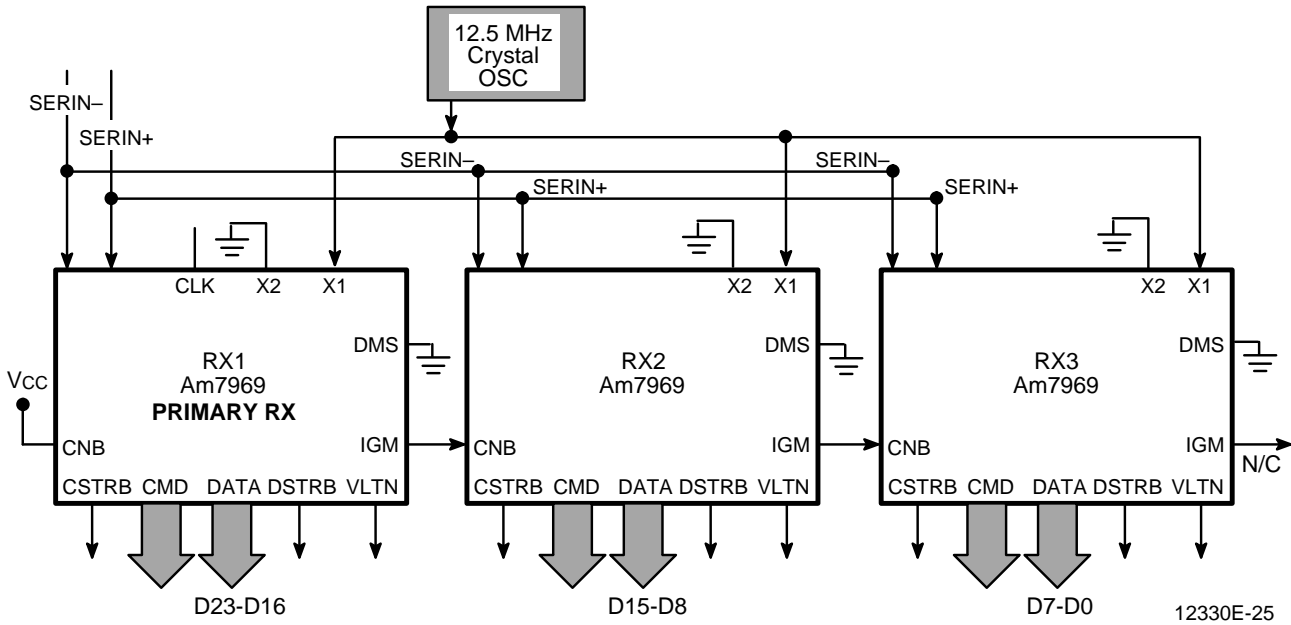

*Transmission line terminations not shown.

The following section describes the functionality of individual pins:

The DSTRB Pin

Any one of the DSTRBs may be used as the user's DSTRB to his system. When an entire word has been received (signified internally by a Sync from the Transmitter) the data in the Receivers are latched out to the output ports and all the DSTRBs are raised (simultaneously) one cycle later. Likewise, if Commands are sent as part of the cascade word, the CSTRB/DSTRB connections must be made appropriately.

Timing description for receivers in cascade mode is included in Figure 7-4.

Figure 7-4 Receiver Timing—8-Bit Cascade Mode

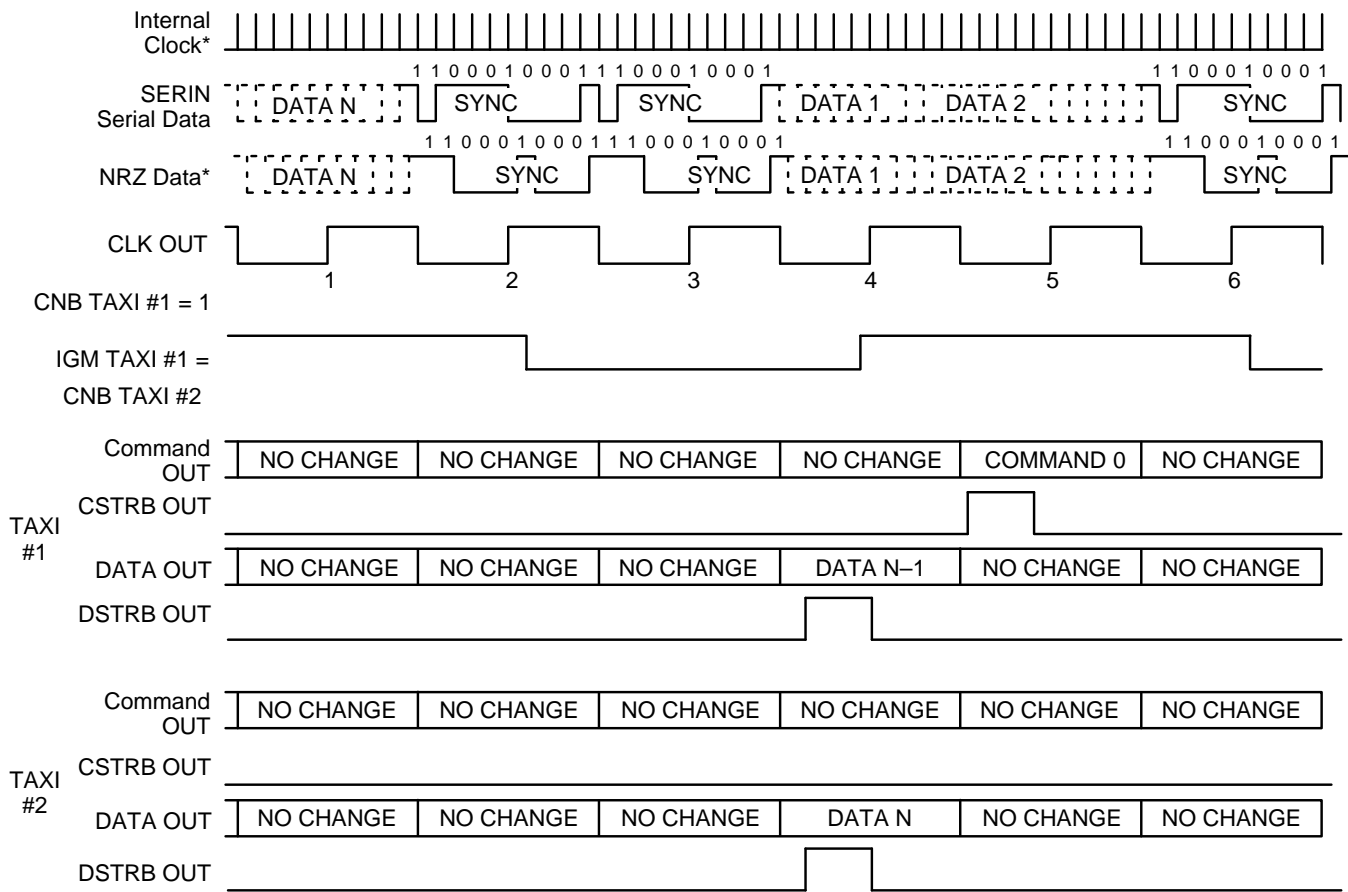

12330E-26

* Internal Signals

If CNB is HIGH, the Receiver will catch the next valid byte of data and hold it. It will not attempt to catch any more data until it sees a Sync command from the Transmitter or until its CNB goes LOW and then HIGH again.

If CNB is held LOW, the Receiver will not attempt to capture any data.

When the Primary Receiver RX1 catches a valid data byte it will raise its IGM (I Got Mine) so the next Receiver RX2 can catch the next byte and so on down the line. After all the receivers in the system have received their bytes a Sync must be sent or the next byte of data will be lost⁽³⁾.

Referring to Figure 7-5 for a system of Cascaded Receivers.

⁽³⁾ In the Auto-Repeat Configuration, a Sync is not required.

Figure 7-5 CNB and IGM Propagating Down Cascaded Receivers

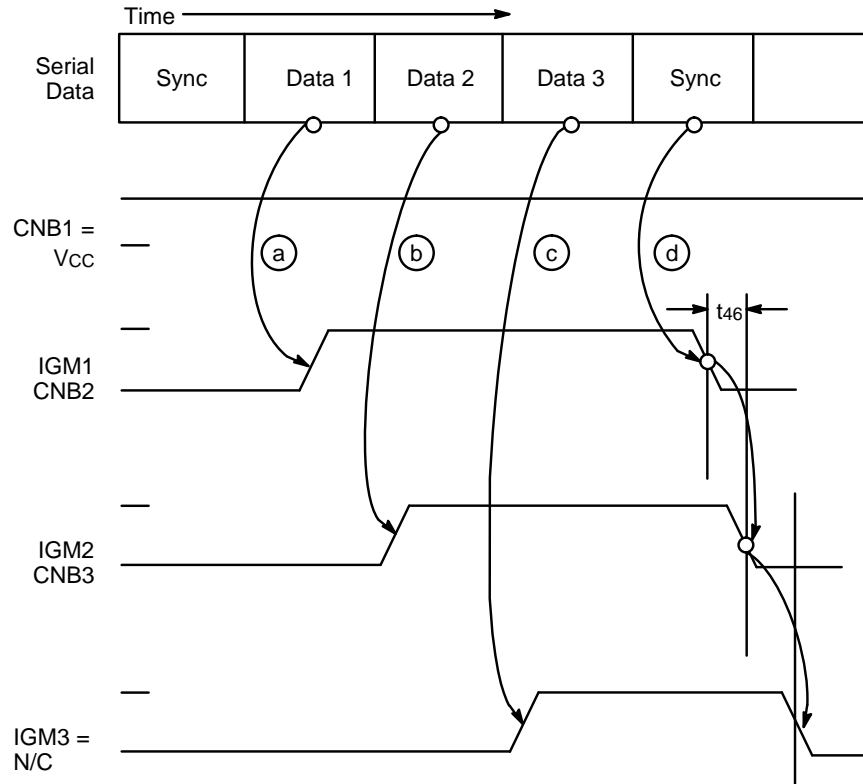

12330E-27

Note: Half of the byte is sufficient for the Receiver to decide whether the byte is a Sync or Data.

When CNB on the first Receiver is raised (Figure 7-3 it is tied to Vcc), its IGM does not follow until the first half of a non-Sync byte is detected in its SERIN. Note that if a Sync is detected, IGM does not go HIGH, since it is a Sync that makes IGM fall.

The IGM on RX1 rises when it sees a non-Sync byte, then since it is tied to the CNB of RX2. RX2 will now be ready to accept the next byte of data.

RX2 will now wait for the next non-Sync byte to come down the SERIN lines. During this time all the other downstream receivers will ignore the data on the SERIN lines because their CNBs are still LOW. In the same way the upstream (Primary) Receiver will ignore the SERIN lines because it has already caught one byte and thus it will continue to ignore the data until it sees another Sync.

The IGM on RX2 rises when it sees the second non-Sync byte.

In this fashion, each Receiver will sequentially get ready to receive data as the CNBs propagate down the IGMs.

When the first Receiver sees a Sync, it will lower its IGM which is connected to RX2's CNB which will lower its IGM and RX3's CNB and so on. In this way the LOW IGM will also propagate down all the Cascaded Downstream Receivers. CNB falling to IGM falling is t_{46} ns.

In normal Cascade mode, the CNB on RX1 is tied HIGH and thus, a Sync has to be sent after all the receivers are full to ensure that RX1 is reset to accept the next byte of data.

The Data Out Lines

When a Receiver sees the Sync symbol it sends the data byte it just received from its Input Latch to its Decoder Latch, and then the receiver lowers its IGM. One more clock cycle is required for the data to go to the Output Latch. At this point DSTRB is raised. In this way all data bytes are output simultaneously from all receivers, two clock cycles after the first Sync (or two clock cycles after a LOW CNB). The DSTRBs of all the receivers rise simultaneously as well.

The VLTN (Violation) Pin

In Cascade mode the VLTN pin acts exactly like a Data Out line. The timings are exactly the same. Violations do not change the output of the IGM pin. i.e., a Receiver that gets a VLTN will still raise it's IGM signal as if it received a valid data byte.

7.3 Auto-Repeat Configuration

7.3.1 Receiver Connections in Auto-Repeat Configuration

In Auto-repeat Configuration the IGM of the last Receiver on the line is inverted and tied to the CNB of the Primary Receiver. This connection eliminates the need to send a Sync between each Data Word.

In a 3-Receiver cascade system, IGM3 is inverted and tied to CNB1. When the IGM of the last Receiver goes high, CNB1 goes LOW.

CNB1 going LOW ripples through the chain pulling each IGM LOW (t46 ns) until finally the last IGM goes LOW again, pulling CNB1 HIGH resetting RX1 to receive new data.

In Figures 7-6 and 7-7, as each Receiver decodes its data byte, it raises its IGM and thus the next Receiver's CNB.

Figure 7-6 TAXI Receiver—Cascaded in Auto-Repeat

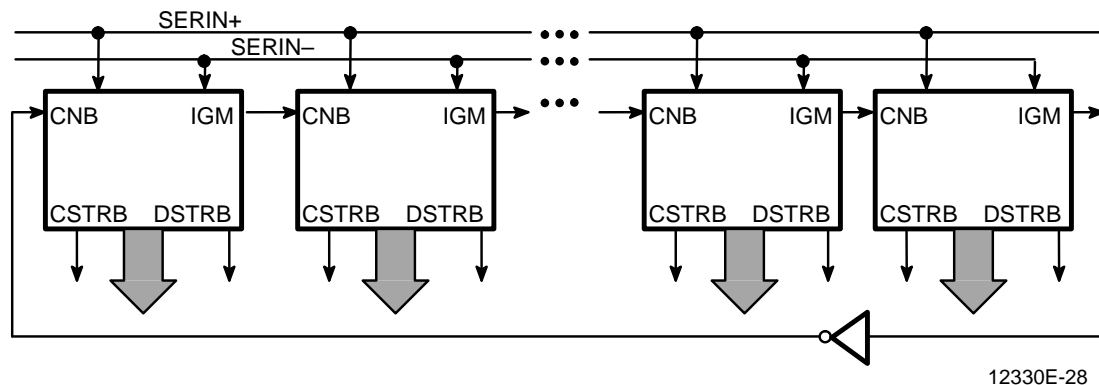
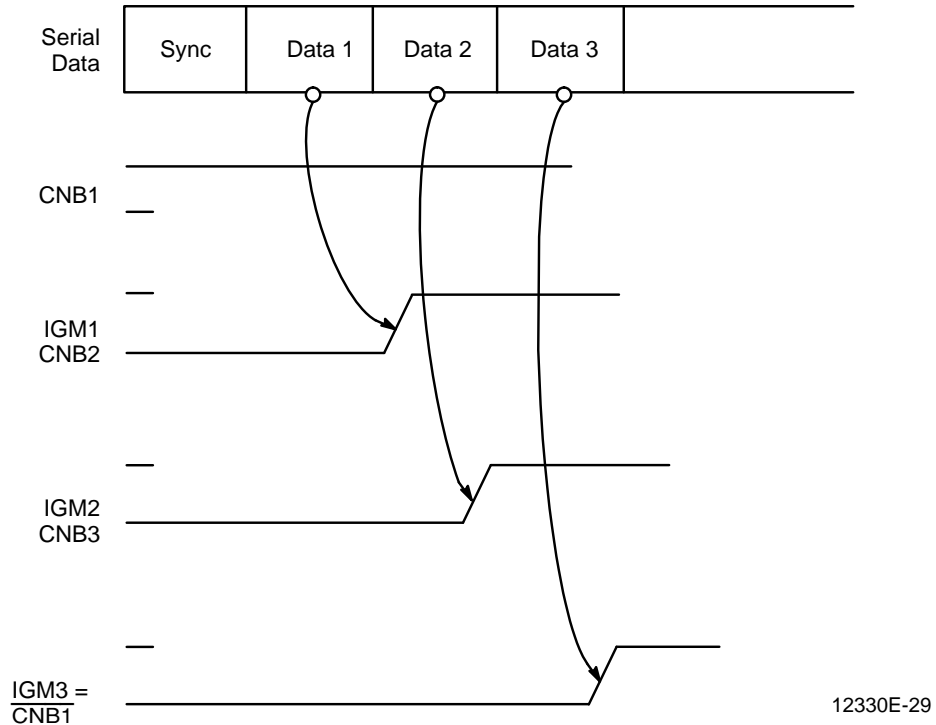

Figure 7-7 Receiver Timing in Auto-Repeat Configuration



Note:

Only when a Receiver has a CNB = 1, can it accept new data. It then raises its IGM when it sees a non-Sync byte. It won't accept another data byte until it's CNB has gone LOW and HIGH again.

12330E-29

When IGM1 goes high, CNB2 goes high. This allows RX2 to decode the next byte and raise it's IGM. IGM2 is connected to CNB3 and RX3 is now allowed to decode the next byte and raise its IGM.

In Figure 7-8 since $IGM3 = \overline{CNB1}$, CNB1 goes LOW.

When CNB1 goes LOW, RX1 is reset and it pulls it's IGM LOW (t_{46} ns).

Since IGM1 is connected to CNB2, RX2 is reset and pulls its IGM LOW t_{46} ns later.

CNB3 = IGM2 goes LOW, which causes IGM3 to follow it LOW t_{46} ns later. IGM3 going LOW makes CNB1 go HIGH again and RX1 is now set to receive the next byte of data on the SERIN.

See Figure 7-9. Thus, the cycle starts over again.

Figure 7-8 Receiver Timing in Auto-Repeat Configuration

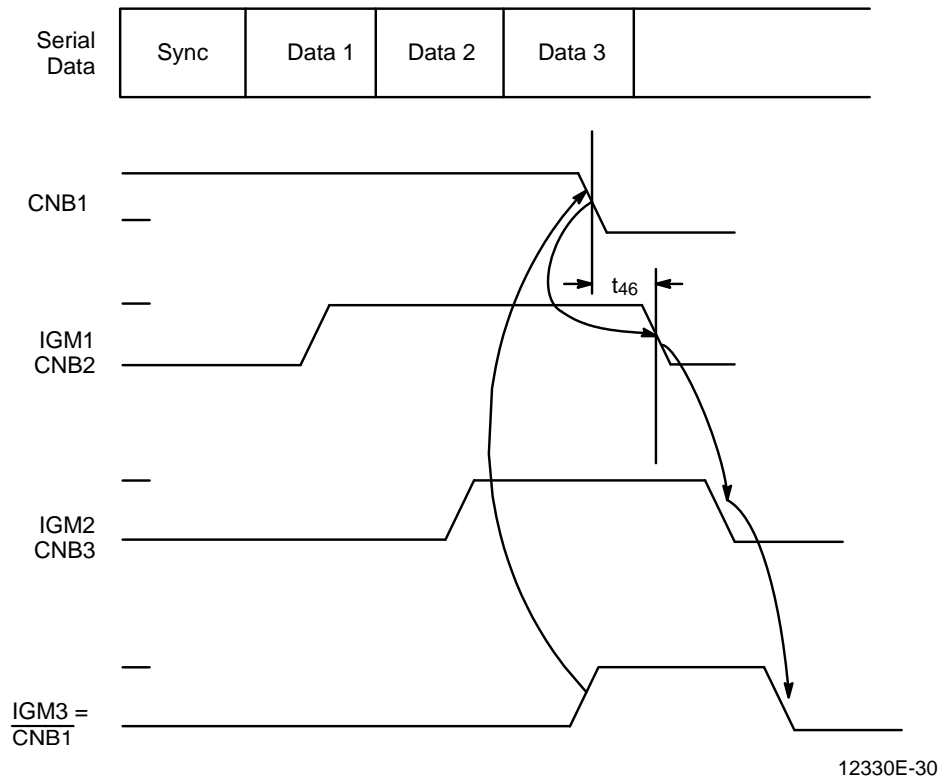

Note:

When IGM3 goes HIGH CNB1 goes LOW. Thus, IGM1 = CNB2 goes LOW t_{46} ns later, and IGM t_{46} ns after that. This will ripple down to IGM3.

Figure 7-9 Receiver Timing in Auto-Repeat Configuration

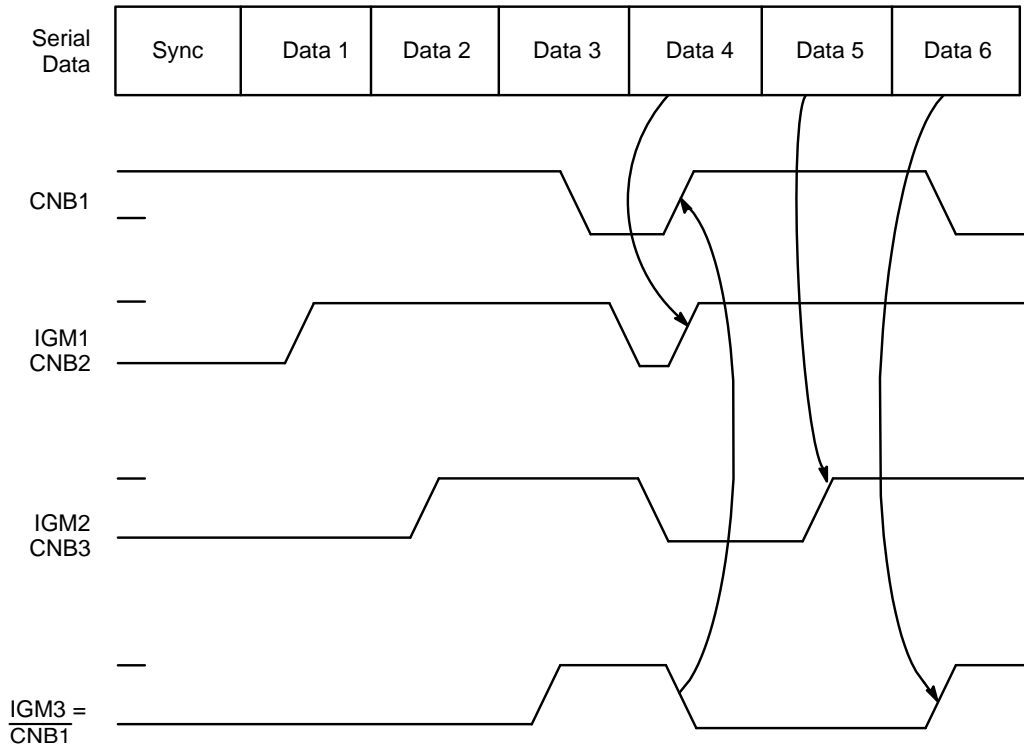

12330E-31

Note: $IGM3 = \overline{CNB1}$ so RX1 is now ready to receive new data. The cycle can now be repeated.

7.3.2 Timing Limitations of the Auto-Repeat Configuration

Note, however, that the t_{46} delay adds up as it ripples through the daisy chain. If the total delay from the first to the last Receiver in the cascade is greater than 1 byte time, parallel data will output 1 byte time later on some Receivers than on others.

The following example is for $t_{46} = 20$ ns and a 12.5 MHz byte rate, the time between the start of one byte to the start of the next is 80 nanoseconds. When IGM on the last Receiver goes HIGH forcing the CNB1 on the first one to go LOW, it will take $20 \times R$ ns (where R is the number of Receivers in cascade) before the last IGM goes LOW again, (allowing CNB on the first Receiver to go HIGH).

In order for the first Receiver to capture the next byte its CNB cannot remain LOW for more than X ns (where X must be less than 1 byte period).

$$X = (20 \times R1) + (\text{inverter delay}) + (\text{CNB to CLK set-up})$$

(R1 is the number of receivers that can be connected in cascade in this format)

The CNB to CLK set-up time is specified as $t_{47} = [(\text{byte time} / n) - 32 \text{ ns}]$

In 8 Bit mode at 12.5 Mbyte/s, CNB to clock setup = $- [(80/10) - 32] = 24$ ns

Figure 7-10 demonstrates an alternative scheme which will allow a virtually unlimited number of receivers to be cascaded. The fan-out of the inverter dictates the number of AND gates that can be driven. Multiple inverters can be connected to the last IGM output if needed. Using this scheme guarantees that all of the receivers in cascade will

output data at the same time. This also guarantees that the CNB on the first Receiver goes active (HIGH) within 2 gate delays + 20 ns after it goes LOW. This leaves enough time for the first Receiver to capture the (R+1)th byte of data.

Figure 7-10 TAXI Receiver—Cascaded In Auto-Repeat Configuration. Configuration 2

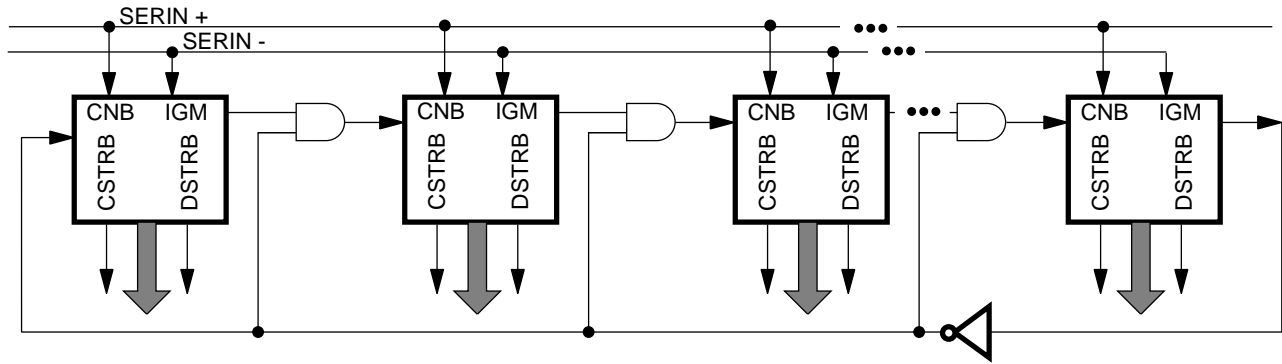

12330E-32

Figure 7-11 TAXI Receiver—Cascaded in Auto-Repeat Configuration. Configuration 3

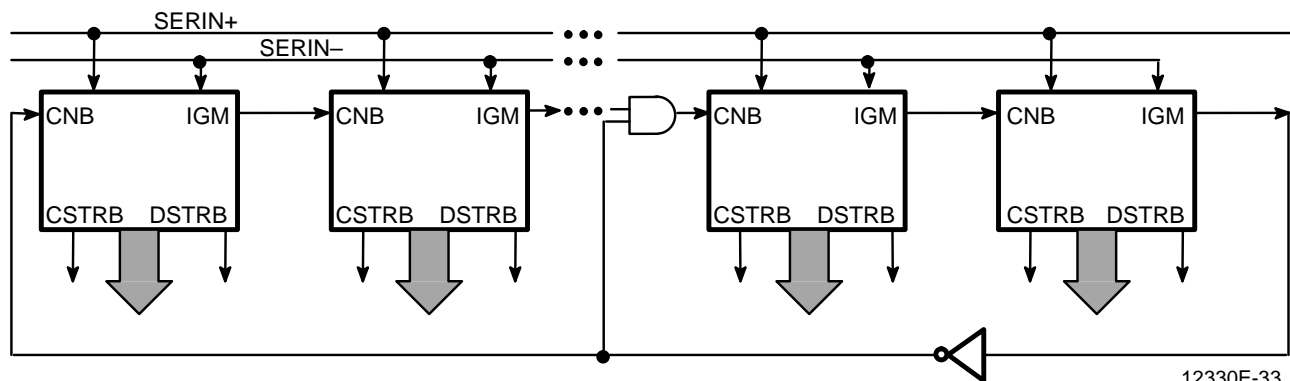

12330E-33

In practice, all the AND gates are not required. Using the above equation for X we can calculate a value of R1 for which X is less than 1 byte period at the appropriate frequency of operation. Then if the number of receivers to be cascaded is greater than R1, an AND gate is needed for every (R1+1)th Receiver in cascade. The other receivers can be directly connected as shown in Figure 7-11.

Syncs in Auto-Repeat Configuration and Recovering from Errors

A Sync in Auto-Repeat Configuration acts much like a Sync in Normal Cascade mode. It resets all the Receivers and their IGMs so the upstream (Primary) Receiver receives the next non Sync byte of data. This remains as the method of recovering from byte framing errors.

7.4 Unbalanced Configuration (Am7968/Am7969-125 Only)

In reality there is no difference in connection between balanced and Unbalanced Configurations. The name only indicates that the number of Transmit bytes and the number of Receive bytes are unequal.

The TAXI Receivers do not care how many data bytes the Transmitter is sending to them. One data byte can be transmitted to several Receivers. The only limitation here is

The serial link will operate in the 40 to 175 MHz range as determined by the byte rate clock, but the byte data rate will be determined by how often the user strobes the TAXI Transmitter. The transmission speed is transparent to the user.

Some applications may have a serial link bandwidth limitation. Typically, this means that the media connecting the Transmitter to the Receiver can only handle serial data rates that are lower than 40 MHz. The user can run the TAXI chips in Test Mode in order to overcome the 40 MHz lower frequency limitation.

For convenience in the following discussions, encoded data width n has been set to 10, corresponding to an 8-bit input byte, (i.e. DMS = LOW).

Since the multiplying PLL is turned off in Test Mode, an external clock source must be supplied to the TAXIs. In normal (non-test) mode, the Transmitter PLL multiplies the *byte* clock by 10. The new 10X clock is called the bit clock or *bitclk*, and is used to transmit the serial data. The Receiver PLL generates the same type of *bitclk* to decode the incoming data and to track and follow any fluctuations in the transmission frequency of the incoming data.

In test mode the Transmitter PLL is disconnected and the internal clock multiplier is switched out. The internal logic is now clocked directly by the signal applied to the CLK pin. The input to the CLK pin now becomes the *bitclk* and must be supplied by the user.

On the Receiver side, the internal data tracking PLL is disconnected in Test Mode. An external clock recovery circuit must be used to allow the Receiver to track the incoming serial data stream. This recovered *bitclk* is supplied to X1. Either a digital PLL or an analog PLL (for faster rates) can be used for clock recovery as shown in Figure 8-2.

The Transmitter and Receiver Test Mode connections and functionality are given in the following section.

8.1 Transmitter Connections

Refer to Figure 8-1.

The TLS pin is left floating. This is the pin that puts the Transmitter in Test Mode.

The $\overline{\text{RESET}}$ pin is left floating. $\overline{\text{RESET}}$ pin function is described in Appendix C, TAXI TIP #89-02. The X2 pin is grounded.

SERIN is left floating (D/C = Do Not Connect).

The DMS pin is set in the appropriate state for 8-, 9- or 10-bit mode as desired by the user.

The CLK is now an input for *bitclk* (the bit rate clock). This means that if the serial transmission rate is to be 1.5 Kbits/s, CLK must be 1.5 kHz.

The ACK pin is raised only when a Sync byte is detected in the Transmitter's shifter latch (note that if STRB is lowered before ACK is seen, ACK will be suppressed. See the STRB/ACK description in Section 7.1).

The X1 input is the reset pin for the internal state machines and can be left unconnected in operational systems. For testing purposes, the following steps are to be taken upon power up or initialization.

1. X1 should be kept HIGH and the Transmitter *bitclk*ed about 15 times
2. X1 should be lowered and the Transmitter *bitclk*ed about 200 times.

This serves to flush all extraneous data from the buffers and reset all internal state machines. Once this is completed the Transmitter may be Strobed. X1 should be left in the LOW state upon completion of the initialization.

The STRB input must now be strobed only once every $n = 10$ bitclk pulses or more. This will allow time for an 8 bit wide byte to be encoded to 10 bits and shifted out one bit every clock pulse.

The parallel data input pins are provided with new data every 10 bitclk pulses. Setup and hold times remain the same as in non-Test Mode with respect to STRB. (In the non-Test modes, the clock rate is the byte rate and a new data word and a strobe is provided every clock pulse. In test mode, the clock rate is the bit rate so the new data word and strobe are provided every n clock pulses).

In Test Mode the Receiver expects only single ended data. Thus only one of the SEROUT lines from the Transmitter is used. However, both lines must have pulldown resistors to electrically balance the outputs.

Figure 8-1 Transmitter Test Mode Connections

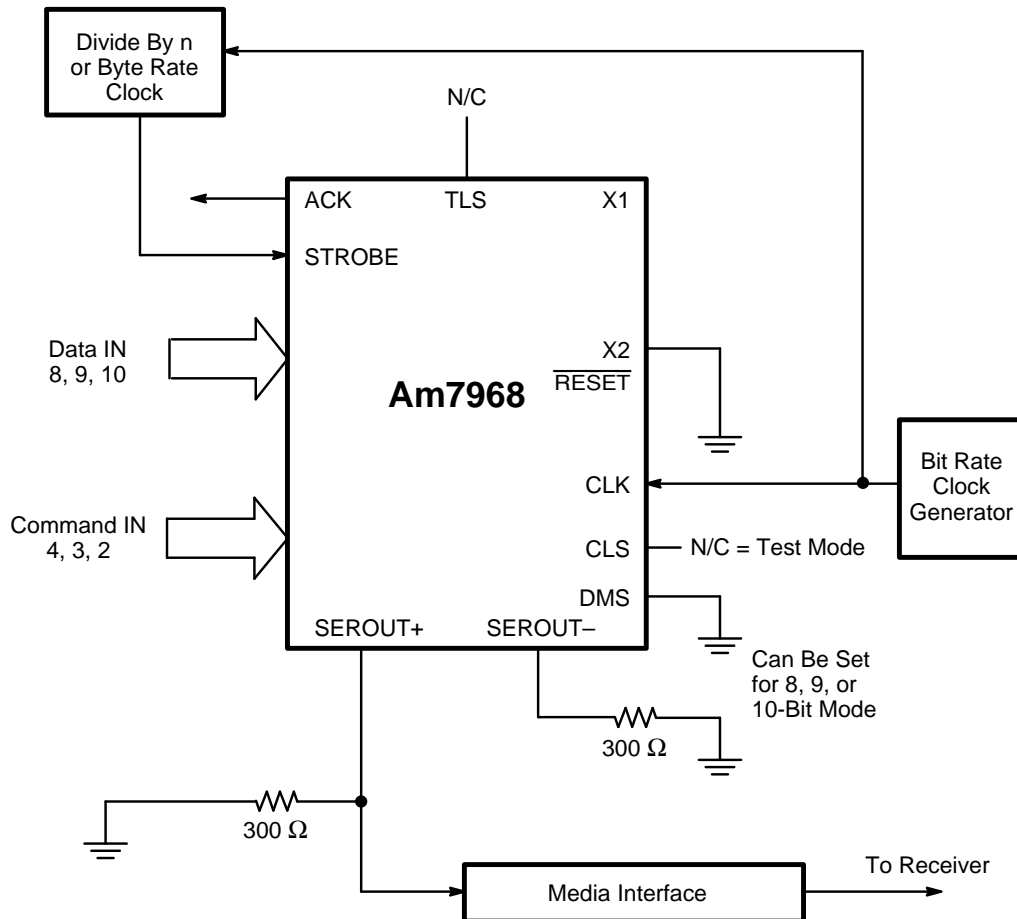

12330E-35

8.2 Receiver Connections

Refer to Figure 8-2.

Grounding SERIN- puts the Receiver in Test Mode. SERIN+ is a single ended 100K ECL NRZ input.

The X1 pin now becomes the bit rate clock input (bitclk), just like the CLK pin on the Transmitter.

The CLK pin remains a *byte* rate CLK out.

8.3 Timing Relationships in Test Mode

The timing parameters in Test Mode are similar to the parameters in standard mode. Propagation delay values remain the same, however bit time relationships are now calculated with respect to the new bit times. For example, using a bitclk = 1.0 kHz, which is a 1 ms period, the byte time $t_{35} = 10 \text{ bits} \times 1 \text{ ms} = 10 \text{ ms}$. In the same way t_{37} , which is the CLK falling to STRB rising delay is now $[2 (t_{35}/n) + 15 \text{ ns}] = 2.015 \text{ ms}$. Note that Setup and Hold times for SERIN to X1 are not specified and must be determined for each application.

Figure 8-2 Receiver Test Mode Connections

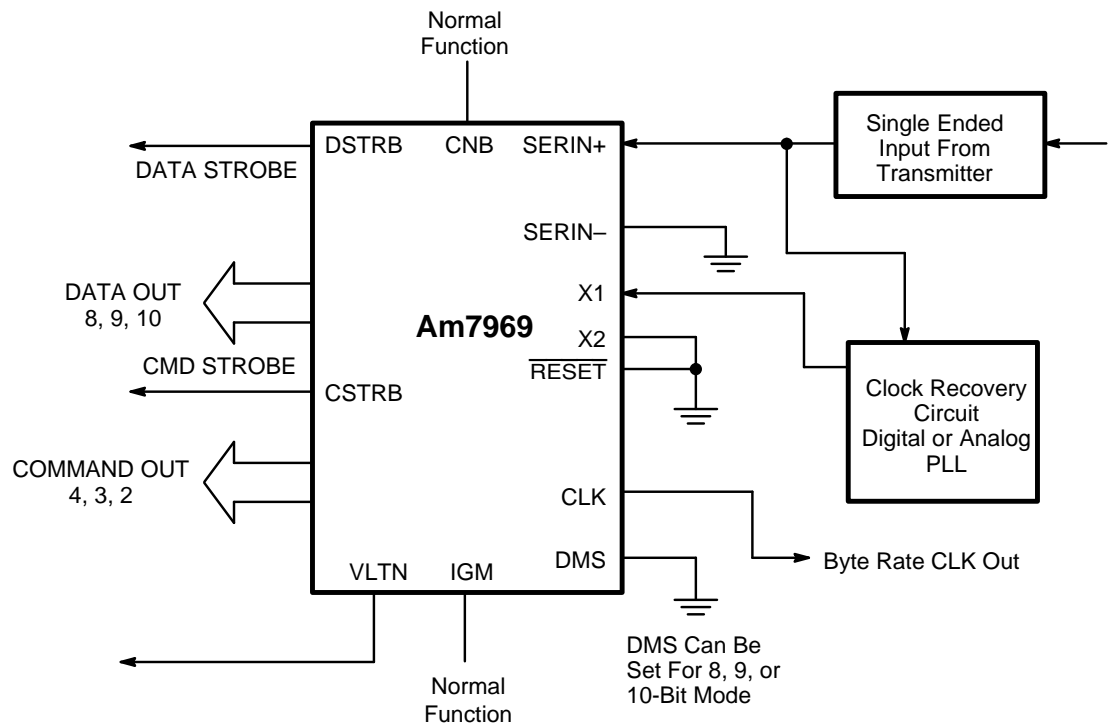

12330E-36

APPENDIX A



Fiber Optic Data Link Manufacturer List

Presented below is a partial listing of fiber optic data link suppliers that manufacture or market optical components in a data rate range compatible with the TAXIchip set. Several of these components have been demonstrated in a bench level evaluation in conjunction with the TAXIchip set.

AMP

1 (800) 552-6752
(416) 475-6222 (Canada)

AT&T Microelectronics

(800) 372-2447

BT&D Technologies

Delaware Corporate Center 11
Suite 200
2 Righter Parkway
Wilmington, DE 19803
(800) 545-4306

Hewlett Packard

Customer Information Center
(800) 752-0900

Sumitomo Electric

777 Old Saw Mill River Rd.
Suite 230
Tarrytown, NY 10591-6725



Error Detection Efficiency

When a received data pattern does not represent a valid coding symbol, the TAXI Receiver asserts the *VLTN* pin to indicate that the current data contains an error.

The Receiver cannot detect the occurrence of a bit error that transforms one valid symbol into another valid but incorrect symbol. This means that the transition error can change a valid data symbol into a different valid data symbol, or in certain cases a valid Command symbol and not be flagged by the Violation pin.

A single noise event on the serial link can cause at a minimum a double bit error. Single bit errors are assumed to be impossible (or at least rare) because NRZI encoding would require that the voltage level on the link be inverted after the event. There is no known error mechanism external to the TAXIchip set which could cause this condition. Having confirmed that all errors are at least 2 bits wide, let us examine the location at which these errors can exist.

Consider the 4B/5B encoded data pattern for the TAXIchip set in the 8-bit mode. The output corresponds to two five bit nibbles for each eight bit data byte. Shown below are four nibbles, or two bytes of encoded data output, with six possible locations for double bit errors within nibble 1 of Byte 2.

Figure B-1

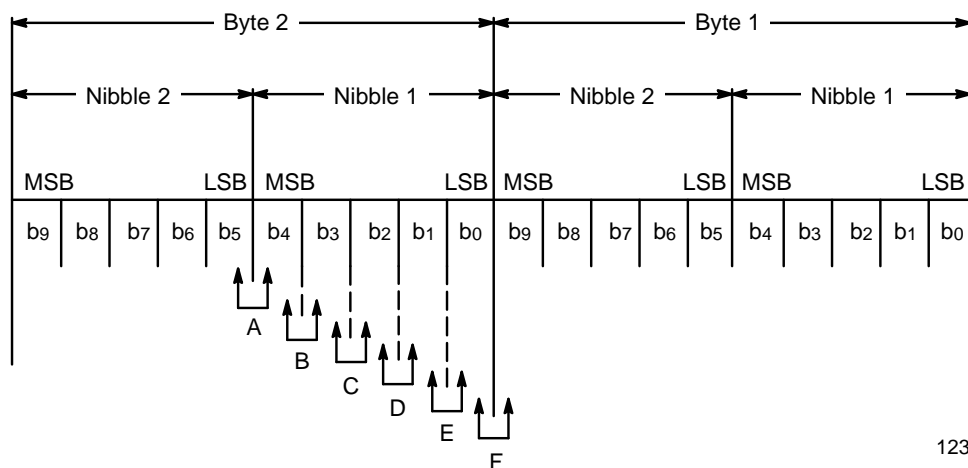

12330E-37

Notes:

Error location A corresponds to a double bit error occurring in the Least Significant Bit of nibble 2 and the Most Significant Bit of nibble 1.

Error locations B, C, D and E occur within the nibble between adjacent bits, and,

Error location F occurs between the LSB of nibble 1 (Byte 2) and the MSB of nibble 2 (Byte 1).

For example, consider transmitting Hex *B* [1011], encoded as 10111. Error *E* occurs changes bits b0 & b1, resulting in encoded pattern 10100, which is Hex 2 [0010]

2 bits changed, and the run length the error = 4 bits,

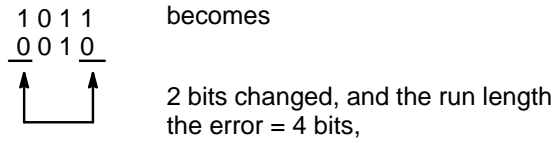

A double bit error can change valid data into a Violation, a valid Command byte, a 1-bit, 2-bit, 3-bit, or 4-bit data error. A summary of the occurrence of these errors for the six error locations for 4B/5B encoding is summarized below in Table B1.

Table B-1 Error Type

A	B	C	D	E	F
V=5	V=5	V=5	V=3	V=3	V=1
C=5	C=3	C=5	C=3	C=5	C=1
1B=4	1B=0	1B=2	1B=4	1B=0	1B=14
2B=2	2B=8	2B=4	2B=6	2B=6	2B=0
3B=0	3B=0	3B=0	3B=0	3B=0	3B=0
4B=0	4B=0	4B=0	4B=0	4B=2	4B=0

Table B-2 Similar reasoning for the 5B/6B encoding scheme results in seven possible error locations, and the summary of the occurrence of these errors is listed below:

A	B	C	D	E	F	G
V=13	V=16	V=12	V=6	V=9	V=10	V=5
C=3	C=2	C=2	C=4	C=3	C=4	C=3
1B=10	1B=0	1B=0	1B=0	1B=8	1B=2	1B=22
2B=6	2B=14	2B=12	2B=14	2B=12	2B=12	2B=2
3B=0	3B=0	3B=4	3B=6	3B=0	3B=0	3B=0
4B=0	4B=0	4B=2	4B=2	4B=0	4B=4	4B=0

Utilizing this information one can determine the efficiency of the violation logic in the TAXI Receiver. Figure B2 summarizes the violation effectiveness, as well as depicting the number of bits in error in the undetected corrupted data. This information can be extremely useful in determining what, if any, additional error detection schemes should be implemented. Figure B3 graphically represents the run length of the corrupted data for the undetected errors. As shown in this figure, there are a small percentage of unlimited run length errors. This is due to the few data patterns, which, when corrupted will cause a false Sync pattern to be generated. This pattern will cause a running error which will continue until the next valid Sync realigns the byte edge to its proper position. While these *false Syncs* occur very rarely, these are the most dangerous errors in a TAXI system, this very well may dictate the maximum user *packet* size.

Figure B-2

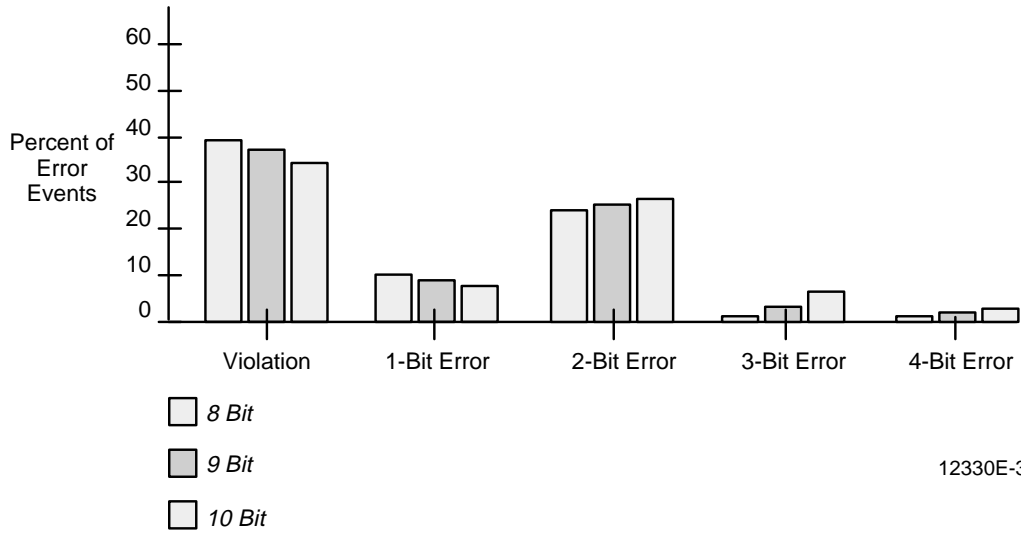

12330E-38

Figure B-3

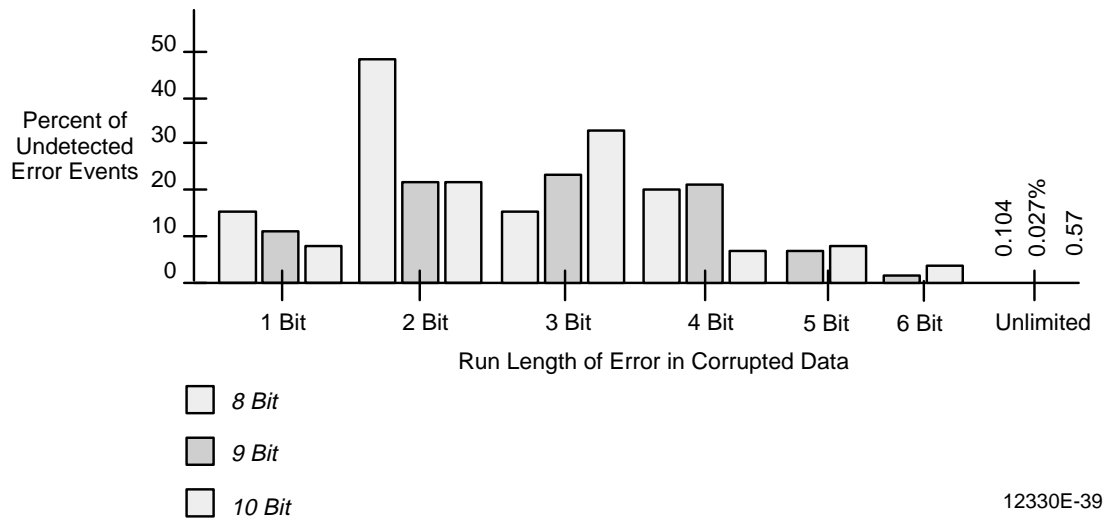

12330E-39



TAXI Technical Information Publications

The TAXI applications team has documented questions and answers that are general purpose in nature and applicable to a wide range of applications. This documentation has taken the form of TAXI Technical Information Publications (TIPs), and have been incorporated in this revision of the technical manual. The contents of this appendix are as follows:

TAXI TIP # 1:	Subject: Receiver Response to Loss of Input Signal
TAXI TIP # 2:	Subject: TAXIchip $\overline{\text{RESET}}$ Pin Function
TAXI TIP # 3:	Subject: Proper Use for TAXI Sync
TAXI TIP # 4:	Subject: TAXI PLL Lock-Up During Power-On!
TAXI TIP # 5:	Subject: TAXIchip set Crystal Specification
TAXI TIP # 6:	Subject: TAXI for FDDI Applications
TAXI TIP # 7:	Subject: Synchronous vs. Asynchronous Strobe
TAXI TIP # 8:	Subject: TAXI Receiver Lock Time
TAXI TIP # 9:	Subject: TAXI Bridge: Bidirectional TAXI Communication
TAXI TIP # 10:	Subject: TAXI Receiver CSTRB and DSTRB Pulse Width
TAXI TIP # 11:	Subject: Using Receiver CLK Output to Run a TAXIchip Transmitter
TAXI TIP # 12:	Subject: TAXIchip Pins Internal Circuit
TAXI TIP # 13:	Subject: Demuxing a TAXIchip Receiver to Output Multi-Byte Words
TAXI TIP # 14:	Subject: 32-Bit Multiplexed Cascade with the TAXIchip Transmitter
TAXI TIP # 15:	Subject: General Device Information for 125/175 MHz TAXIchips
TAXI E.B. Nov '89:	Subject: TAXIchip Error Rate Example



TAXI Technical Information Publication #89-01

Subject: Receiver Response to Loss of Input Signal

Question:

It is desired that the TAXI Receiver outputs be predictable and stable during conditions when the TAXI Transmitter may cease transmitting (power-off) or is disconnected. How can a system designer predict the TAXI Receiver outputs or use the TAXI Receiver in a system where the TAXI Receiver must appear *Inactive* under these conditions? This applies to both Coaxial and Fiber-Optic Systems.

Answer:

The key to this problem is interpreting the loss of incoming Tx data as a Quiet-Line-State and either flagging the system accordingly or gating the TAXI Receiver outputs with an *inactive* flag.

In a Coaxial coupled system the loss of incoming signal drive will cause the TAXI Receiver inputs to rest at the input termination bias voltages. The differential serial inputs will normally be at equal potential. To properly interpret a loss of signal as a constant *quiet* state the input termination bias voltages must be altered slightly from each other. To allow reliable interpretation of the offset as a constant logic state, the offset voltage should typically be set to about 50 mV.

The TAXI Receiver will interpret the *Quiet-Line-State* differently depending upon the operation mode (8-bit, 9-bit, or 10-bit). In 8-bit mode the Receiver will generate continuous CSTRB's with the Command outputs at F Hex, or all HIGH. In the 9-bit and 10-bit modes there is no defined interpretation of an incoming quiet data stream. This will cause the TAXI Receiver to generate continuous CSTRB's and the Violation output will be continuously HIGH. A one-shot may be used to determine Violation=HIGH duration and then generate an *inactive* flag, or the system may interpret the Violation output directly as an *inactive* or *invalid* condition flag and halt data-dependent system operations during any byte with Violation=HIGH.

In a Fiber-Optic coupled system two methods may be used, depending on the Optical Receiver construction. If the Optical Receiver has a *Carrier-Detect* output this signal may be used to flag an inactive state. If there is no *Carrier-Detect*, one may be generated using an ECL one shot arrangement which will detect loss of edges after a predetermined period of say, for example, 80 bit times. The actual time may vary depending on the desired response to loss of data.

In either condition, if the Receiver recovered Byte Clock (CLK) is used as a system clock, then the system must be able to tolerate a shift in the CLK frequency of typically about +/-3% to allow for Rx-PLL offset and drift during this period. (If the Optical Receiver begins oscillation when the fiber is dark, the TAXI Receiver PLL may attempt to track the oscillation resulting in an indeterminate Rx recovered clock frequency. Optical Receiver dark response thus becomes a possible system concern.)

TAXI Technical Information Publication #89-02

Subject: TAXIchip $\overline{\text{RESET}}$ Pin Function

Question:

How long must the $\overline{\text{RESET}}$ pin be held low in order to insure that the TAXIchip has reset?

Answer:

The $\overline{\text{RESET}}$ pin is level sensitive and after a LOW input level is asserted it instantaneously forces the Phase Lock Loop (PLL) to its lowest possible frequency (approximately 5 to 10 MHz). A 1 ms LOW pulse should allow sufficient time for the PLL to reach a stable state. Preliminary tests conducted in the lab reported that for the full TAXI frequency and temperature range, the time required to recover from a reset was less than 100 μs .

Resetting is intended to allow graceful recovery from the rare occurrence of a PLL lock-up due to noise bursts on the serial data lines, as may occur when light is removed from certain optical links. In a fiber-optic coupled system, loss of optical signal may cause the optical receiver to oscillate, causing the TAXI Receiver to track the oscillation to an indeterminate frequency. Care must be taken to avoid the oscillation, or a reset can be used to recover from it. After reset, the PLL begins tracking incoming data, and the byte boundary remains undefined until the transmitted data includes a Sync (JK). The Sync is a unique bit pattern which forces the TAXI Receiver to align itself to the correct byte boundary.

In a coaxial system when a loss of incoming signal drive occurs, there will be no data for the TAXI Receiver to track. This *quiet* state will be interpreted as a continuous data pattern. The Receiver decodes this *Quiet-Line-State* differently depending upon the operational mode selected: 8-bit, 9-bit, or 10-bit. In 8-bit mode the TAXI Receiver will generate continuous CSTRBs with command outputs all high (*F Hex*). In 9-bit or 10-bit modes there is no defined interpretation of an incoming quiet data stream thus generating continuous CSTRBs and forcing the violation output (VLIN) to be continuously high. Further information on the effects of incoming signal drive loss is available in TAXI TIP #89-01, *Receiver Response to Loss of Input Signal*.

TAXI Technical Information Publication #89-03

Subject: Proper Use for TAXI Sync

Question:

What is the proper use for Sync? How often is a Sync needed?

Answer:

When a Transmitter has no data to send, it sends Sync. This symbol allows the Receiver PLL to maintain phase and frequency lock with the transmitter, exactly as would a normal DATA stream. It has the additional special property of being a unique bit pattern that can be used to discover the byte boundaries in an otherwise continuous bit stream.

The Receiver PLL takes some time to achieve phase and frequency lock (as described in section 3.3). After lock is achieved the TAXI Receiver must align the incoming data to the proper byte boundaries. The Receiver logic compares the incoming bit stream (bit by bit and without regard for byte boundaries) with the pattern for Sync, and when it is found, forces an internal bit counter to 0. The internal counter then continues to count bits and run the byte rate logic without further reference until another Sync is found.

From this description of the Sync function, it is obvious that only *ONE* Sync symbol is ever really required to define the byte boundary for the TAXI Receiver if the internal counter continues to count correctly. It is unlikely that the internal logic function will make a mistake, and therefore the counter will continue to count off the proper number of bits per byte forever. However, there is some chance that noise can corrupt DATA into a pattern that looks exactly like the Sync symbol. (The chance is about 0.13% of all possible error types.) When this happens, the byte boundary is forced to an incorrect position, and all data following is decoded incorrectly. TAXI Receiver violation detection logic may or may not flag the errors, but the Receiver cannot distinguish properly framed data from incorrectly framed data. The only thing that can correct this running error is another Sync.

The minimum number of Syncs required in a user data stream is dictated by the system sensitivity to running errors, and the system's built in error detection mechanism. However, it is a good practice to send a Sync every 1000 bytes.

Systems that send *packetized* data, should allow a Sync between each packet. This will assure that if an error occurs, it will be terminated at the end of the packet and will not corrupt the succeeding packets. Systems that send data at a rate slower than the TAXI byte rate will have Sync automatically inserted as pad characters, so the user may not need to specifically insert them.

Systems that send *byte* or *short phrase* data (commands or control words, for example) might send a Sync before each *byte* or *phrase* to assure that the message is not missed because of an earlier framing error.

From this discussion it should be clear that there is no *RIGHT NUMBER* of Syncs to send with TAXI data. The correct number is dependent on the type of data the user is sending, and the system sensitivity to running errors.

TAXI Technical Information Publication #89-04

Subject: TAXI PLL Lock-Up During Power-On!

Question:

Is there a recommended power-on sequence for the TAXI chips to prevent PLL lock-up?

Answer:

Early versions of the -70 TAXI chips did have some sensitivities associated with hot-plug-in lock-up, fast V_{CC} rise time, and/or power supply sequencing during power-on causing occasional PLL lock-up. These potential problems were addressed in the -125 TAXI chips with an improved circuit design. The -125 TAXI chips do not exhibit any known power-on problems, but a PLL Reset function is available on a package pin and may be used to restart the PLL if problems occur.

Use of the external PLL Reset pin should not be necessary with the -125 TAXI chips, but there may be specific situations where its use may be helpful with the TAXI Receiver. There are possible situations where large amounts of noise may occur on the Receiver serial data inputs. Under these conditions the Rx-PLL may attempt to track the noise to an indeterminate frequency. This deviation in frequency may adversely affect data recovery when a good data stream reappears. System requirements may also place a restriction on the allowed clock frequency deviation. Use of the PLL Reset function on the Receiver may assist in the containment of some of these effects.

All V_{CC} s may be powered-on simultaneously with a common supply. It is only recommended that the TAXI GND pins be connected to a common Ground and the V_{CC} pins be separately filtered and decoupled to that Ground. Variations in power-on times due to separate V_{CC} filtering and decoupling are not a problem. Use of a common V_{CC} supply is sufficient as long as noise filtering of the supply at the TAXI V_{CC} pins is adequate, therefore use of separate power supplies for the V_{CC} s is usually not necessary.

Refer to Section 6.1, for more information concerning power supply layout and decoupling. Further information is also available in TAXI TIP #89-02, *TAXI Receiver RESET Pin Function*.

TAXI Technical Information Publication #89-05

Subject: TAXIchip Set Crystal Specification

Question:

What are the design considerations for crystals used with TAXIchip set?

Answer:

The TAXIchip's parallel mode oscillator uses a 4.0 MHz – 17.5 MHz crystal with a frequency tolerance of 0.1%.

Any crystal will oscillate in either series or parallel mode depending upon the type of oscillator used. By specifying parallel mode and the load, the manufacturer will calibrate the crystal in parallel mode at the desired frequency. This could be important in applications where frequency tolerance is critical due to the fact that the resonant frequency in parallel mode is typically 0.02% above the series mode frequency.

As discussed in section 3.3, the time required to synchronize the data recovery circuit in the Receiver is proportional to the delta between the Transmitter frequency and the Receiver PLL resting frequency. The Receiver resting frequency is typically less than $\pm 1\%$ away from its own crystal frequency, due to mismatch between internal circuits. The crystal specification of 0.1% is meant to be small enough to cause a negligible effect on lock time while not increasing the crystal cost (0.025% crystals are quite common). Sometimes tighter frequency and tolerance specifications may be necessary to meet the user's system requirements (i.e. FIFO depth, etc.).

More information on crystal specifications for the TAXIchip set may be found in Section 4.1.1.

A partial list of vendors follows:

Distributor	Typical 12.5 MHz Part Number	Phone Number
I.E.A.	HC18U 12.500	(408) 435-1000
Calmax Corp.	UM-12.5	(714) 957-1299
Monitor Products	MM 49XIE12A-12.5	(619) 433-4510
Anderson Electronics	011-668-03260	(814) 695-4428
Target Electronics	CC025A-12.5	(408) 733-0384

TAXI Technical Information Publication #89-06

Subject: TAXI for FDDI Applications?

Question:

Can the TAXIchip set be used for FDDI physical layer applications?

Answer:

The TAXIchip set is code compatible with the FDDI physical layer but there are restrictions in the design which would cause difficulty in using the TAXIchip set for the physical layer of an FDDI node. The TAXIchip set by itself cannot be used to build a fully compliant FDDI node, although it provides several of the functions required.

The TAXI Transmitter is compatible with FDDI at the physical layer electrical interface and can send all codes specified by FDDI. An exception to the encoding is that Quiet-Line-State (QLS) is defined as *fiber-dark* for FDDI, requiring a static SEROUT=LOW, and the Transmitter defines the equivalent of QLS, as *Command F*, as *no-transitions*, with no control of the static logical state.

The TAXI Receiver is also compatible with FDDI at the physical layer electrical interface and can recognize the codes specified by FDDI, with restrictions. The restrictions concern Master-Line-State (MLS), Halt-Line-State (HLS), and the carrier detect function. MLS and HLS are terms describing a data stream composed of a consecutive string of HQ and HH symbols respectively, representing a *line-state* condition. The Receiver will decode these symbols, but it does not count them to signal *line-states* as required by FDDI.

MLS and HLS are relatively long run-length signals with 10 and 5 bit-times between transitions respectively, as compared to a maximum limit of 3 bit-times for data. The Receiver PLL was designed for wide operating frequency range, with tradeoffs in the ability and time required to capture long run-length data sequences. The FDDI specification allows 100 μ s for the Receiver to lock upon and detect MLS following a long period of QLS. A typical TAXI Receiver will meet these criteria but the production parts are neither tested nor guaranteed for this condition. There are no problems associated with tracking the MLS signal once the PLL has acquired lock.

HQ and HH, within the TAXI Receiver, require proper byte framing for detection. MLS and HLS as specified by FDDI are not framed, therefore the transition may be located at any of the ten bit locations. The result, as decoded within the TAXI Receiver, will be as follows:

MLS:	00100 00000	=	HQ	CMD-A	10% probability
	00000 00100	=	QH	CMD-D	10% probability
	all other	=		Violation	80% probability
HLS:	00100 00100	=	HH	CMD-8	20% probability
	all other	=		Violation	80% probability

The FDDI line state definition does not preclude the insertion of an occasional sync into the MLS or HLS data stream for proper framing, solving the recognition problem. If full FDDI compliance is required, MLS and HLS must be detected external to the TAXIchip set.

The carrier detect function, as specified by FDDI, requires the flagging of a QLS to the MAC layer as long as the fiber is *dark*. The TAXI SERIN inputs must be static for this condition to be met by the TAXI Receiver. This problem must be addressed directly by the Optical receiver or gating of its outputs.

Functions of the FDDI MAC layer interface are not directly addressed in the TAXI designs.

TAXI Technical Information Publication #89-07

Subject: Synchronous vs. Asynchronous Strobe

Question:

When should synchronous vs. asynchronous strobing be employed?

Answer:

Inputs to the TAXI Transmitter can be strobed asynchronously, but with some limitations. In *local* mode, the STROBE edge can rise at any time, without regard for placement within any particular byte. The data associated with the STROBE (STRB) will be latched into the Transmitter, and will be transmitted at the earliest opportunity. If some system limitation insures that a second STRB cannot ever be within the same byte time (80.0 ns at 125 MHz), then there is no need to observe the ACK output of the TAXI Transmitter.

If no such guarantee exists, then ACK must be used to insure that no more than two STRBS lie within a single byte. Again there is no restriction on STROBE placement within a byte, since ACK will always insure that the capacity of the TAXI input buffer is not exceeded. The TAXI input buffering can handle two STRBS within a single byte, but this additional buffer must be *flushed* by the absence of a STRB in a given byte before another two-strobe byte is encountered.

In an early revision of the 70 MHz Transmitter, there was a particular placement of STROBE with respect to the falling edge of CLK, that could cause loss of data. This led to several revisions of technical literature mentioning the *Prohibited Zone*, and *Uncertainty Zone*. This restriction in STROBE placement has been removed in the 125 MHz version of the Transmitter. T6 in the data sheet, now refers only to the exact placement of the internal byte boundary. Knowledge of this time is only important for synchronous systems to predict in which byte the data will appear.

The only restriction on Local mode asynchronous STRB input would be in systems which require contiguous data output from the TAXI Receiver. It is possible that when strobing asynchronously, there will be an occasional byte with no strobe, and another nearby byte with two strobes. The Transmitter has sufficient buffering to handle this condition, but will pad the missing byte with a Sync character. For systems that have this restriction, STRB should be made synchronous with the CLK of Transmitter.

TAXI Technical Information Publication #89-08

Subject: TAXI Receiver Lock Time

Question:

In a fully operational system in which both the Transmitter and Receiver are powered on, how long will it take for the Receiver to lock to new data after a quiet line?

Answer:

When data transmission stops and the link becomes quiet, the TAXI Receiver PLL will drift to its natural resting frequency which by design, is less than 3% away from the reference frequency applied at the X1 pin.

When data appears on the line, the Receiver PLL will achieve phase lock in a time which is proportional to the incoming data edge density and PLL loop bandwidth. Because this lock time is dependent on the data being transmitted, the time it takes for the receiver to lock will depend on the specific system application. In Section 3.3, three types of data are represented and their calculated lock times are shown. By dividing the lock time for a specific data pattern by the X1 clock period, the number of bytes to lock the PLL can be calculated.

Because time to lock is dependent on many variables, it is represented as a typical time. If time to lock is critical to the specific application, we suggest you allow at least the times shown.

Although there is no guaranteed specification for time to lock, a test is run (using a JK pattern) as part of AMD outgoing tests to ensure that all devices can achieve lock within a reasonable time. The test is performed by sending JKs for 640 μ s, and then without interruption, a full rate functional test is run. For the test to pass, the PLL must lock to the JK pattern and then track the incoming data perfectly.

TAXI Technical Information Publication #89-10

Subject: TAXI Receiver CSTRB and DSTRB Pulse Width

Question:

What is the maximum CSTRB and DSTRB pulse width?

Answer:

The internal logic of the TAXI Receiver determines the pulse width of CSTRB and DSTRB based on the timing of an internal clock (Bit Clock). Under normal conditions, the pulse width will be 4-bit times wide in the 8-bit mode, and 5-bit times wide in the 9- and 10-bit modes. An exception to this typical width is upon re-sync which can cause the pulse to be expanded by up to 5 bit times as the byte boundaries are re-aligned to the incoming data stream.

The number of bit times used to represent data differs based on the operational mode; in 8-bit mode, data is encoded into 10 bits, in 9-bit mode 11-bits, and in 10-bit mode 2 bits. For example, a Receiver operating with a 12.5 MHz crystal and utilizing 8-bit mode will have a clock period of 80 ns ($1/12.5 \text{ MHz} = 80 \text{ ns}$). Internally the Receiver divides this period by 10, forming the internal bit boundaries used to represent the encoded data. This example yields a 8 ns ($80 \text{ ns}/10 = 8 \text{ ns}$) bit period, which translates to a internal clock rate of 125 MHz ($1/8 \text{ ns} = 125 \text{ MHz}$). Figure 11. shows a timing diagram of a TAXI Receiver internal clock and its relationship to CLK, Data, and Strobe outputs. The Receiver utilizes this divided clock to define its internal logic states.

The CSTRB and DSTRB signals are generated by using these logic states and have a fixed relationship to the incoming encoded data. The figure shows that from the beginning of the byte (state 0), the CSTRB or DSTRB delay is two internal clock periods before going high, and the signal remains high for four internal clock periods then returns to a low logic level. Actual pulse width will vary from this ideal width due to signal rise and fall delay, propagation delay and effects of loads external to the Receiver. The data sheet parameters reflect these delays and normal manufacturing guard bands.

Figure 11 (8-Bit Mode Example) TAXI Receiver Internal Clock Distribution

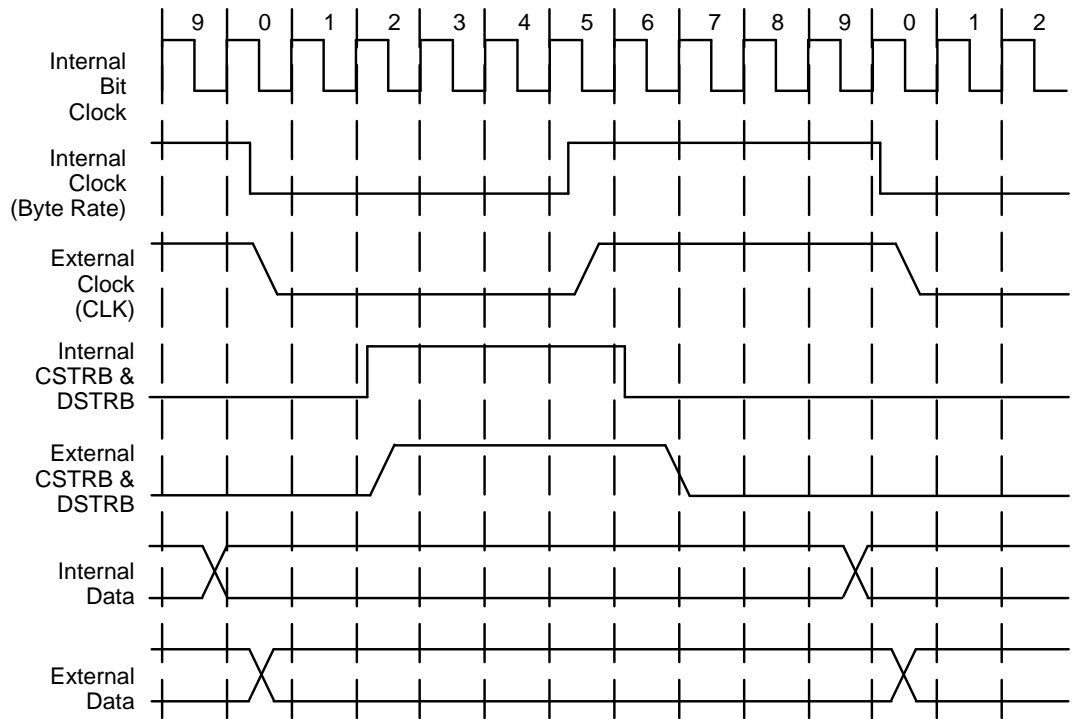

12330E-40

TAXI Technical Information Publication #89-11

Subject: Using Receiver CLK Output to Run a TAXI Transmitter

Question:

Is it possible to use the Receiver CLK output to drive the X1 input of a TAXI Transmitter?

Answer:

To assure accurate transmission of data, the Transmitter must have a stable, jitter free, byte rate reference to its multiplying PLL. This is typically derived from a crystal and can be connected to any crystal controlled and noise free TTL source.

The Receiver synchronizes its internal clock with the incoming signal and recovers data and clock for use by the receiving host system.

In the process of sending high speed data over typical serial links, the data may be affected by noise from various sources. The PLL in the Receiver removes this noise and delivers a synchronized clock to the Receiver logic and to the host system. However, some of the noise may feed through the PLL and appear on the CLK output. The CLK output can jitter as much as 2 ns when recovering data from a noisy link. This will not typically affect normal logic functions, and can be ignored. If the Receiver must realign its byte boundary, it will stretch CLK to the new alignment position and thus protect the host logic from shortened CLK cycles.

These noise and phase jumps make the Receiver CLK output undesirable for use as a Transmitter frequency source.

For systems that MUST use synchronized clocks (for example to avoid FIFO re-timing logic) it is possible to filter the Receiver CLK output and make an adequate reference for the Transmitter.

There are two basic approaches to provide this filter. The first is to use a crystal filter (Figure 12). When placed between the Receiver CLK and Transmitter XI, the crystal filter can be effective in attenuating system jitter to levels nearly comparable to crystal controlled reference clock levels. By the nature of a crystal filter, as the frequency of the crystal used in the filter and the data rate frequency vary, the phase of the output varies. This will make the filter seem to have a variable delay (+ or -) which must be accommodated by the users logic.

The second method is to use a PLL tracking filter (Figure 13). The jitter attenuation through the PLL is less than that through the crystal filter because the PLL has a bandwidth several orders of magnitude larger. The PLL provides a solution whose merits lie between the simplicity of the crystal filter and the need for tight crystal tracking and matching. The PLL filter is relatively straight forward. Attention to proper grounding and board layout should be followed. The PLL filter is more tolerant of component and environmental variations than the crystal filter.

Figure 12 Crystal Filter

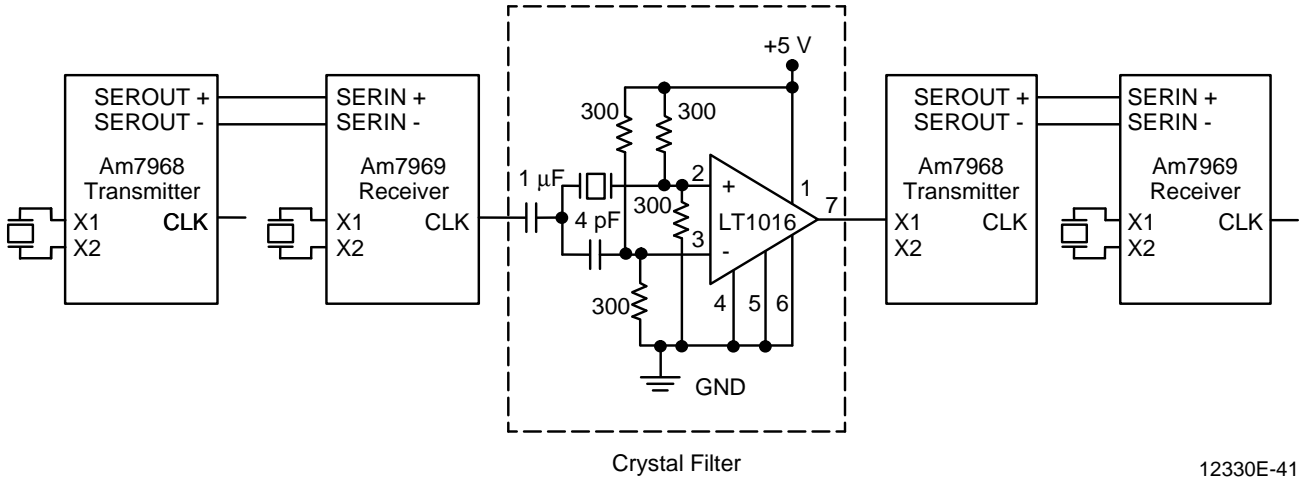

Note: All crystals used are of same type.

12330E-41

Figure 13 PLL Filter

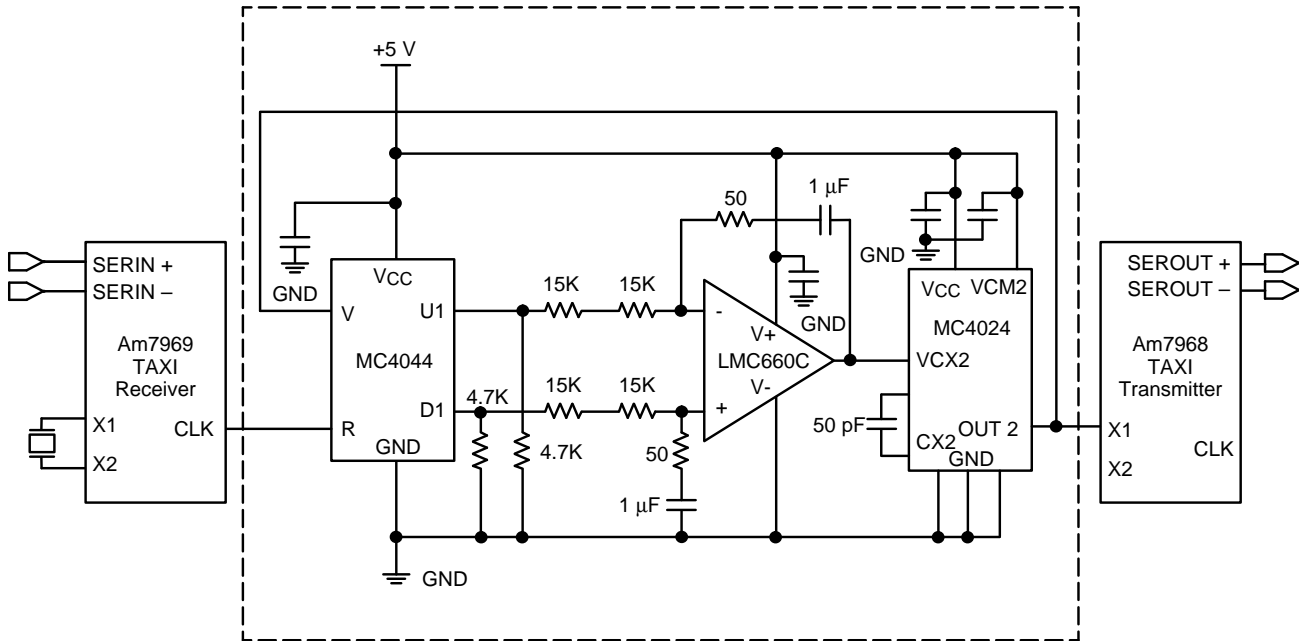

Notes:

- Filter components were chosen for the following loop parameters:
 Noise Bandwidth = 10 kHz
 Damping Factor = 0.5
 Natural Frequency = 3.18 kHz
- Refer to Motorola MC4024, MC4044 and National LMC660C data sheets for specifications.

12330E-42

TAXI Technical Information Publication #89-12

Subject: TAXIchip Pins Internal Circuit

Question:

What do the TAXIchip I/O circuits look like?

Answer:

There are five different input circuits and two different output circuits in the TAXIchip set. Each I/O circuit has Electro Static Discharge (ESD) protection circuit attached to it.

The five input types are: TTL Input, ECL Input, Three State Input (TSI), High Threshold Input (HTI), and Oscillator (OSC).

The two output types are: TTL Output and ECL Output.

Each I/O circuit and the ESD circuit are shown on the following page. The following table lists all Transmitter and Receiver pins and their I/O type.

Transmitter			Receiver		
Pin	Pin Name	I/O Type	Pin	Pin Name	I/O Type
1	ACK	TTL OUT	1	DO3	TTL OUT
2	STRB	TTL IN	2	DO2	TTL OUT
3	SEROUT+	ECL OUT	3	DO1	TTL OUT
4	SEROUT-	ECL OUT	4	DO0	TTL OUT
5	V _{CC2}	5 V	5	IGM	TTL OUT
6	V _{CC1}	5 V	6	$\overline{\text{RESET}}$	HTI
7	V _{CC3}	5 V	7	V _{CC1}	5 V
8	$\overline{\text{RESET}}$	HTI	8	V _{CC2}	5 V
9	DMS	TSI	9	SERIN+	ECL IN
10	CLS	TSI	10	SERIN-	ECL IN
11	SERIN	ECL IN	11	DMS	TSI
12	CI0	TTL IN	12	DSTRB	TTL OUT
13	CI1	TTL IN	13	CSTRB	TTL OUT
14	DI9/CI2	TTL IN	14	VLTN	TTL OUT
15	DI8/CI3	TTL IN	15	CO0	TTL OUT
16	DI7	TTL IN	16	CO1	TTL OUT
17	DI6	TTL IN	17	DO9/CO2	TTL OUT
18	CLK	TTL OUT	18	DO8/CO3	TTL OUT
19	X2	OSC	19	CLK	TTL OUT
20	X1	OSC	20	GND1	GND
21	GND2	GND	21	GND2	GND
22	GND1	GND	22	X1	OSC
23	DI0	TTL IN	23	X2	OSC
24	DI1	TTL IN	24	CNB	TTL IN
25	DI2	TTL IN	25	DO7	TTL OUT
26	DI3	TTL IN	26	DO6	TTL OUT
27	DI4	TTL IN	27	DO5	TTL OUT
28	DI5	TTL IN	28	DO4	TTL OUT

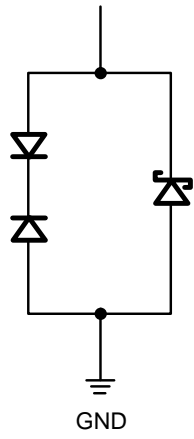

12330E-43

ESD

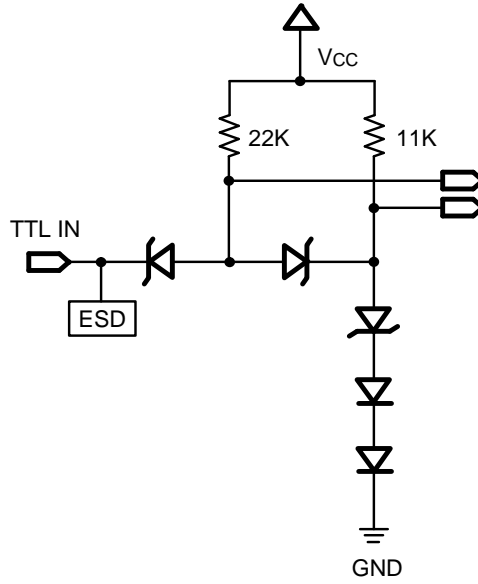

12330E-44

TTL IN

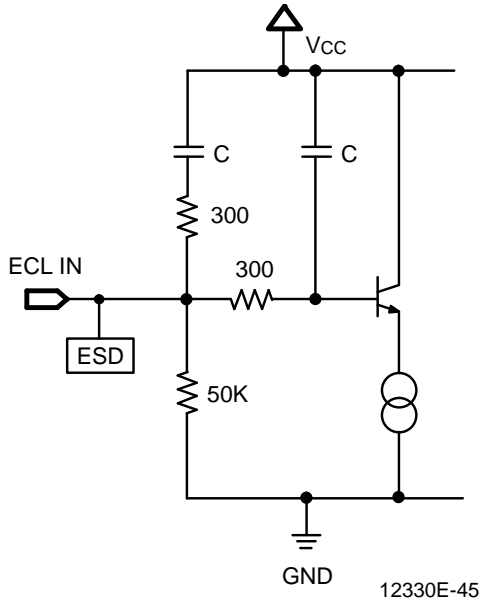

12330E-45

ECL IN

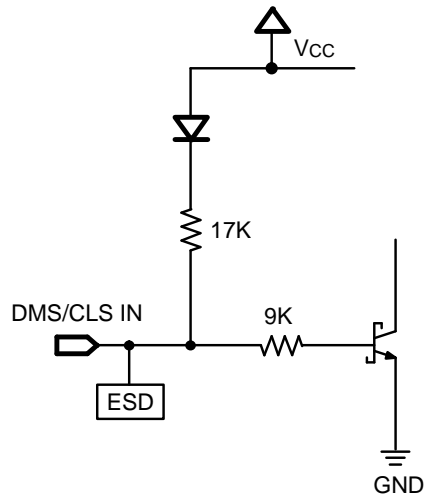

12330E-46

Three-State IN

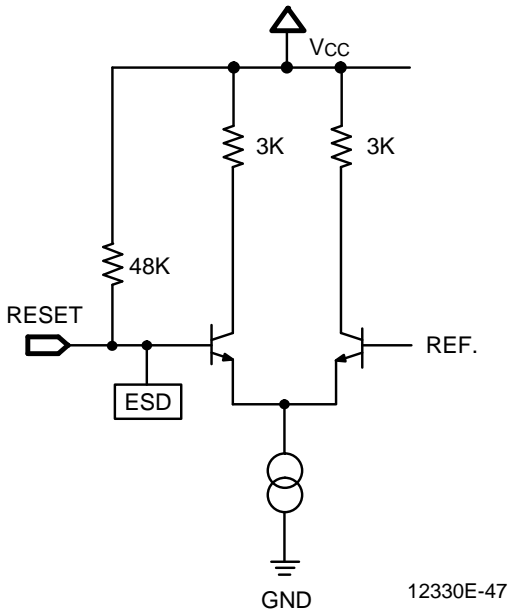

HIGH Threshold IN

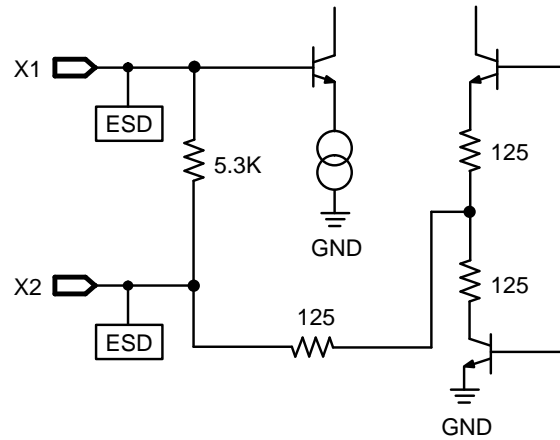

Oscillator

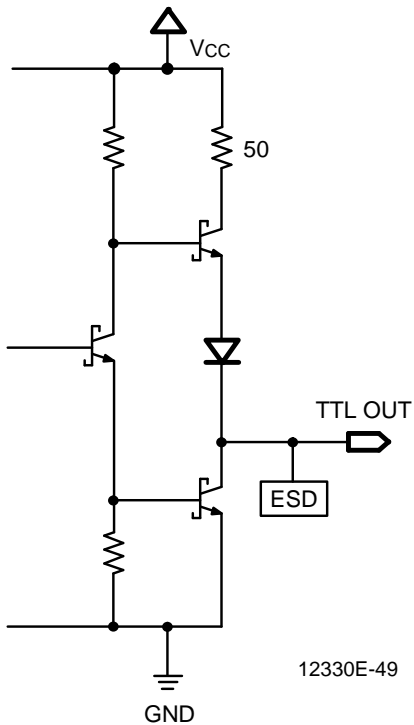

TTL OUT

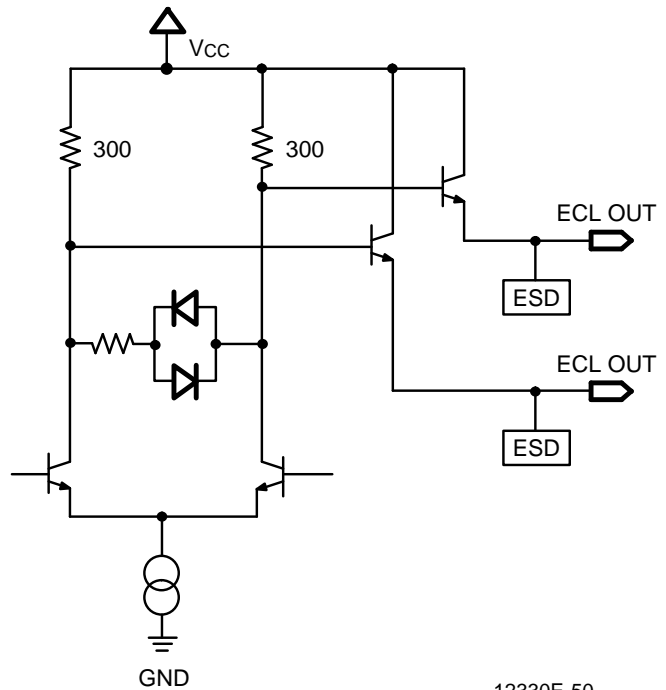

ECL OUT

TAXI Technical Information Publication #89-13

Subject: Demuxing A TAXIchip Receiver Output to Multi-Byte Words

Question:

How can a single TAXI Receiver be used to receive multi-byte words?

Answer:

INTRODUCTION

For systems that require data reception wider than a single byte, a single TAXI Receiver can be used to cascade the multiple bytes. This operation allows the data to be demultiplexed from a single serial link and used by an external system.

In the following example, data is captured sequentially and output in the form of four 8-bit words. Commands, which can also be transmitted are not used in this example in order to clarify the basics of the technique. Some simple modifications to include commands will be presented at the end of this technical note.

The circuit shown in Figure 14 illustrates the logic configuration that has been built and tested in the laboratory using nominal commercial parts. The circuit handles blocks of data typically ranging from four bytes to 64K bytes.

The TAXI Receiver converts the serial information that is received by the SERIN+/- inputs to the data information that is output by the D0-D7 Data pins, C0-C3 Command pins, and the DSTRB, CSTRB, and VLTN pins. This data information output by the single receiver is used by the *controller* to capture the incoming data and output it four bytes at a time.

FUNCTIONAL DESCRIPTION

Controller Circuit:

The *controller* consists of a shift register constructed of four D flip-flops and a 3-input NOR gate. The shifter is loaded with a 1 that progresses through the flip-flops sequentially clocking the first column of four registers which capture the incoming data. When the 1 is shifted through the fourth flip-flop, it raises the PCO signal for the CLKOUT D flip-flop. On the following rising edge of the /CLK signal the bytes of cascaded data are simultaneously clocked out through the second column of four registers that buffer the cascaded data to the outside system.

Controller Clock:

The clock for the *controller* circuit is generated by OR-ing DSTRB and CSTRB. This ensures that the DSTRB signal is captured for output to the external system. These signals also prepare the way for a simple upgrade to allow the use of commands (explained later).

Sync Commands:

When not receiving blocks of data, Sync Commands (bytes) are received which keeps the TAXI Receiver locked onto the correct byte rate and byte boundaries. This ensures proper capture of the data at the beginning of the next block. In addition, before a block of data is to be sent, a Sync Command must be received to reset the counter to the proper byte alignment and initialize the system. The Sync Commands are sent by default in the system because they are automatically inserted whenever a byte time passes without a STRB (no data to send) pulse at the transmitter. It is important to note that the Receiver generates a CSTRB and outputs zeros on the Command lines when a Sync Command is received.

Figure 14 Logic Diagram of Cascaded Data with One TAXI Receiver

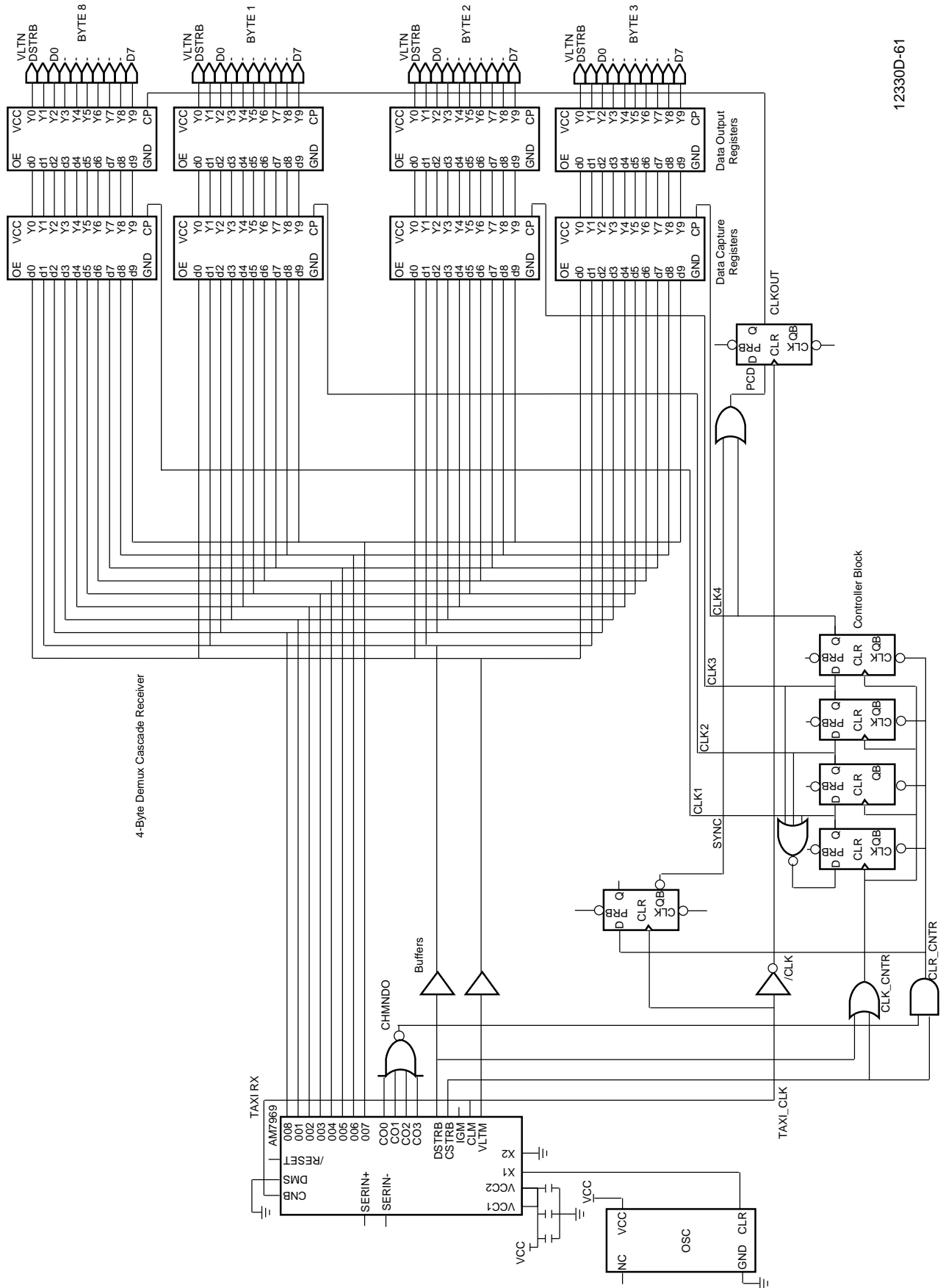

12330D-61

The circuitry that handles the Sync Commands or Sync Bytes generates several signals. The CMND0, CLR_CNTR, Sync and PCO are the signals that are generated by Sync Command logic. The CLR_CNTR signal is generated from the CMND0 and the CSTRB signal which signify a Sync Command has been received. CLR_CNTR clears the *controller* and then is latched by the rising edge of the Receiver CLK to form the Sync signal. The Sync signal then generates an active PCO signal. The CLKOUT is then driven High on the following rising edge of CLK if CLK4 has not already driven the CLKOUT signal High. The Sync Command only clocks out the data when it is received before the fourth byte of data has been received. In all other cases, the data is clocked out by the logic involved with the fourth state of the controller. The Sync Commands that follow this Sync Command hold the CLKOUT signal High to effectively hold the *controller* circuitry in a constant state of reset with no change to the output data.

Buffering:

The buffering of signals should also be considered for this design. In this example, the data outputs from the TAXI Receiver drive the first column of four low power registers. This design does not exceed the driving capacity of the Receiver, but if different parts are used, load calculations should be redone.

This system should work with any standard logic, although logic families should not be mixed unless timing considerations have been made. This particular example uses low power Schottky devices with relatively fast low power output registers.

TIMING CONSIDERATIONS

Some critical timing considerations must be met to ensure the proper operation of this design. In order to capture the DSTRB signal, the timing of DSTRB going active and the rising edge of the CLKx signals from the *controller* must agree with the setup and hold times of the first column of registers. To ensure capture of Sync Commands, the CLR_CNTR signal becoming active and the rising edge of the Receiver CLK must agree with the setup and hold times of the Sync flip flop. To prevent glitches on the CLKx signals and the potential capture of incorrect data, the timing between CLR_CNTR rising and CLR_CNTR becoming active must be considered, CLR_CNTR needs to become active at a time before CLK_CNTR can effect the output of CLKx. The timing diagram is shown in Figure 16.

Figure 16 shows the timing of the system where one Sync Command is received between data blocks being received. The premature Sync Command is not shown, but can be derived by following the given timing diagram and known responses of the logic given in Figure 15.

UPGRADE NOTES

Command Line Handling:

To add the capability to receive Commands in this design, only a few additions are necessary. Since this design uses 8-bit data mode, 4-bit commands can be used. It will be necessary to add command storage registers four bits wide as well as command output registers four bits wide to output these Command lines correctly. The CLKx signals as well as the CLKOUT signals for the existing registers need to be connected to these new registers. The CLKx signals may need to be buffered to meet fanout limitations of the *controller* circuitry.

Control Signals:

The signals that need to be output by the new features do not add to the logic. The circuitry to capture the CSTRB signal is already designed into the system. The DSTRB signal can be used as a CSTRB indicator, active Low, as well as a DSTRB indicator,

active High, without any additional logic. The VLTN signal is used for both Command and Data violations. Buffering of the DSTRB and VLTN signals may be necessary as illustrated in Figure 15 to meet the drive requirements of the first column of registers.

Data/Command Output Note:

In this system, when a nonSync Command byte is received the data line values corresponding to that byte will change to the values last output from the *TAXI Receiver* data lines. Conversely, when a data byte is received the command line values for that byte will change to the values last output from the *TAXI Receiver* command lines. This is a characteristic of the example given and depends on how the command and data information is latched.

Altering the Number of Output Bytes:

The above described design is an example of a four byte cascaded serial data receiving system. The same design techniques can be used to expand or reduce the number of bytes output at a time by the system. The considerations that should be taken into account for an altered system deal with board space and part cost in accordance with the requirements of the situation at hand. For board space note see the PAL Usage section below.

PAL Usage:

In this system, the use of a PAL could greatly reduce the amount of board space used. The PAL could incorporate all of the flip-flops and buffering logic as well as the first column of registers that capture the system information. The reason a PAL was not used in the system described above was to help ensure the understanding of the design concept. For this application it is recommended that the timing considerations mentioned before should be investigated to ensure proper operation of the system.

Figure 15 Timing Diagram of 4-Demux Cascaded Receiver

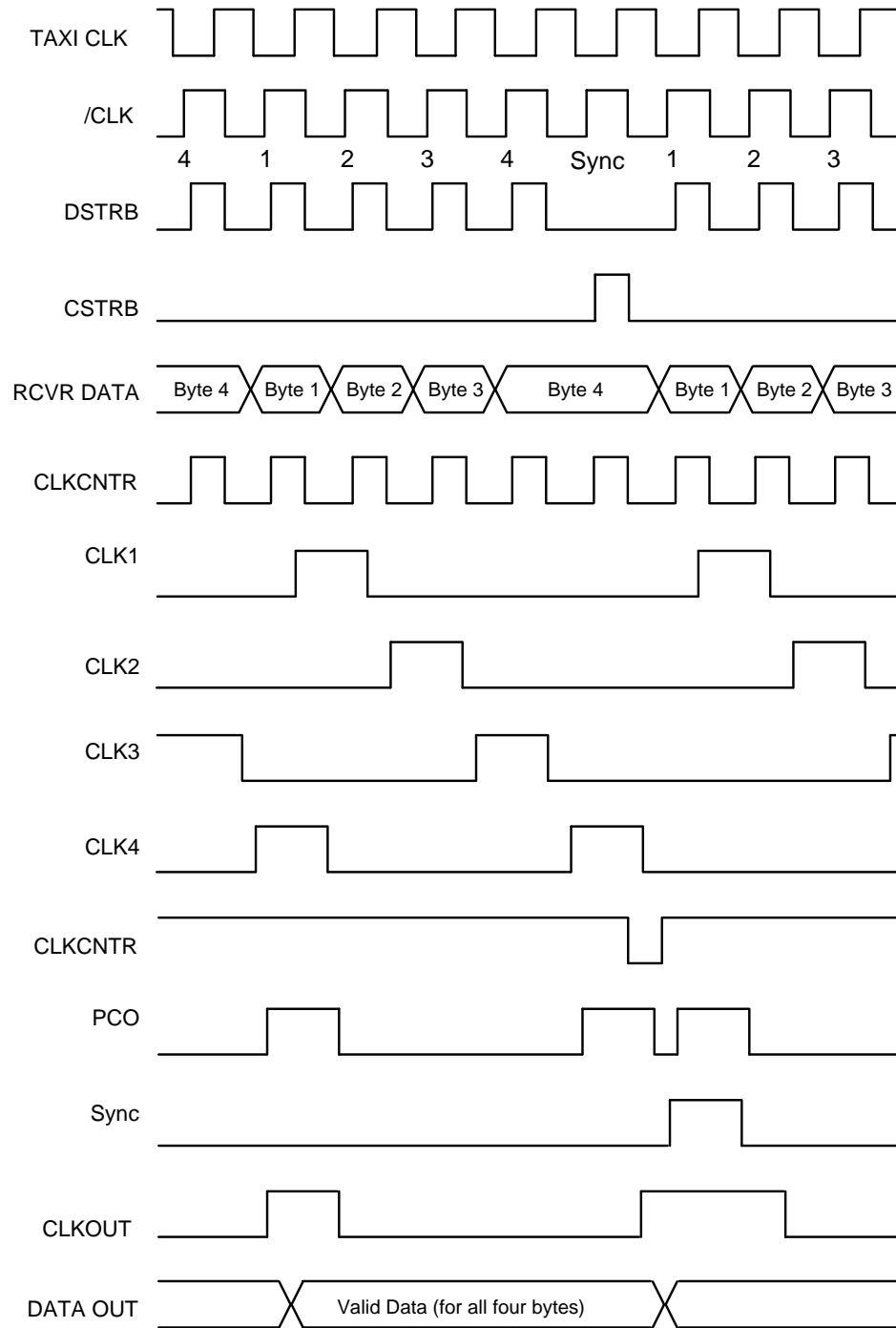

12330E-52

TAXI Technical Information Publication #89-14

Subject: 32-Bit Multiplexed Cascade with the TAXIchip Transmitter

Question:

How can a single TAXIchip Transmitter be used to send n-byte data words?

Answer:

I. INTRODUCTION

Many systems have DATA/CMD paths wider than the twelve lines available per TAXI Transmitter. AMD TAXI applications has designed a circuit which economically multiplexes data words longer than eight bits using one TAXI Transmitter. The following discussion is specifically for an Am7968 Transmitter with a 32-bit data word, but is also applicable to systems with shorter or longer data words (with or without commands).

II. ADVANTAGES

There are several advantages to using the multiplexed data scheme utilizing one TAXI Transmitter as opposed to a system using several Transmitters:

- 1) To implement the mux circuit for 32 bits requires one Am7968 TAXI Transmitter and three relatively small integrated circuits. A 32-bit wide data path without multiplexing requires four Am7968 TAXI Transmitters.
- 2) Four Am7968 TAXI Transmitters require more board real estate than three SSI parts and one TAXI Transmitter.
- 3) Four Am7968 TAXI Transmitters will dissipate about 3.5 W, while one Am7968 and three SSI chips dissipate only 1.25 W. The power saving is even more dramatic if optical data links are being used. A design using four TAXI Transmitters and four Am79h1000T optical data links would dissipate over 5 W of power. The same 32-bit wide system using the multiplexing circuit would dissipate only 2.6 W!

III. IMPLEMENTATION

Implementation of the 32-bit multiplexed transmitter circuit is straightforward. (See Figure 11). In addition to the Am7968 TAXI Transmitter, the following parts are required:

- (1) 74LS00
- (1) 74LS20
- (1) 74LS174

A group of buffers with tri-state outputs (four Am29C821s in this example), would likely be required in any type of point to point communication application and might already be available in the host system. Additionally, a number of termination resistors are required. The number and values are dependent upon the type of coupling and the media used.

IV. OPERATION

Referring to Figure 15, the data to be transmitted is assumed to be simultaneously loaded into the buffers when a strobe pulse is input to the system. The controller for the mux is the 74LS174, which is wired as a shift register. As a 0 (which occurs on strobe) is shifted through the register, each buffer is enabled in turn. The NAND gate (U1) at the input of D1, ensures that only a single 0 is possible while the registers are being selected. The TAXI CLK signal, which is used to clock the 74LS174, is inverted to provide set-up time to ensure that no false strobes reach the TAXI Transmitter. The other four-input NAND gate (U2) enables the two-input NAND gate (U3), so that the Transmitter will be strobed while there is data available in the buffers.

Jumpers are provided on the outputs of Q4 and Q5 to be inverted (U7) and fed back to the first NAND gate (U1). If Q4 is shorted back to the strobe input, the system will run in *auto-repeat ACK 0* mode. This means that there will be a strobe on every clock cycle. In this mode a sync will never be sent. If the output of Q5 is shorted back to the strobe input, the system will run in *auto-repeat ACK 1* mode. This means that a sync will be automatically inserted in between each group of four data bytes.

On the receiver end of the link, the option is left up to the designer to either use four Am7969 TAXI Receivers or to demultiplex the data and use only one Receiver.

Figure 16 has been included to give a detailed schematic of the circuit with an Am7969 TAXI Receiver on-board to complete the data path. Figures 17, 18, and 19 show typical outputs for auto-run ACK0, auto-run ACK1 and Normal run modes.

V. CONCLUSION

To increase the length of a data word beyond eight bits, multiplex the data into an Am7968 TAXI Transmitter. This method uses less power, less board space, and lowers the parts cost of the system.

Figure 17 AUTORUN ACK 0 (No Sync Between Data Bytes)

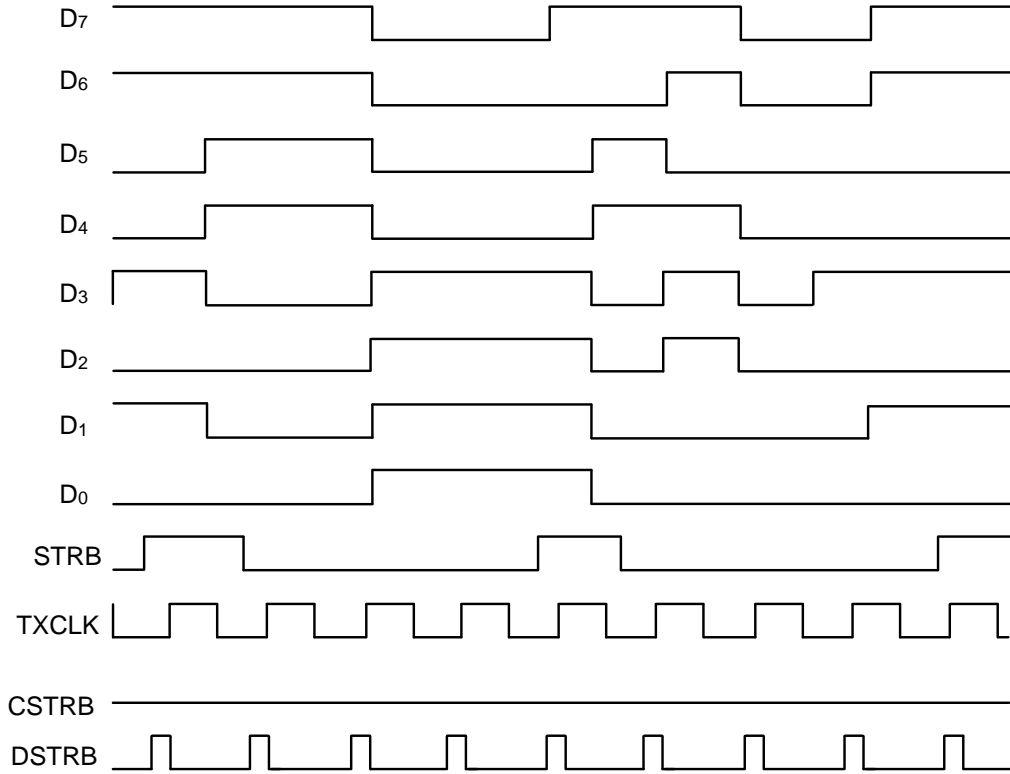

12330E-54

Figure 18 AUTORUN ACK 1 (One Sync Between Every Four Data Bytes)

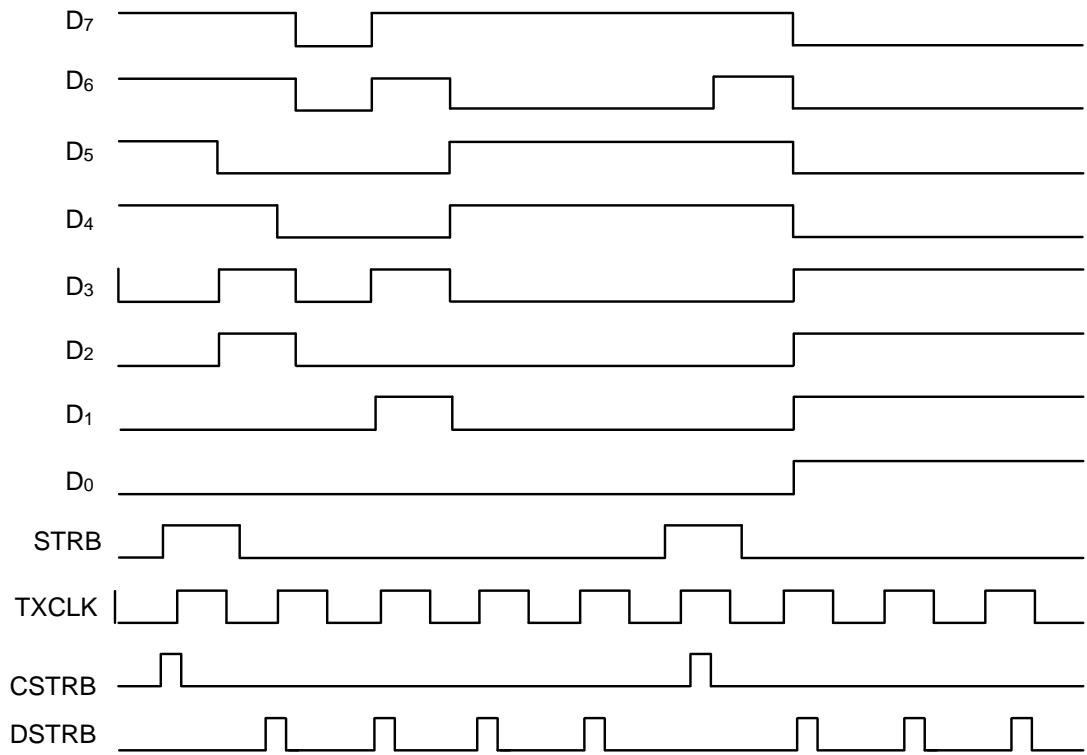

12330E-55

Figure 19 Normal Run Mode (Transmission of Syncs Depends on Host)

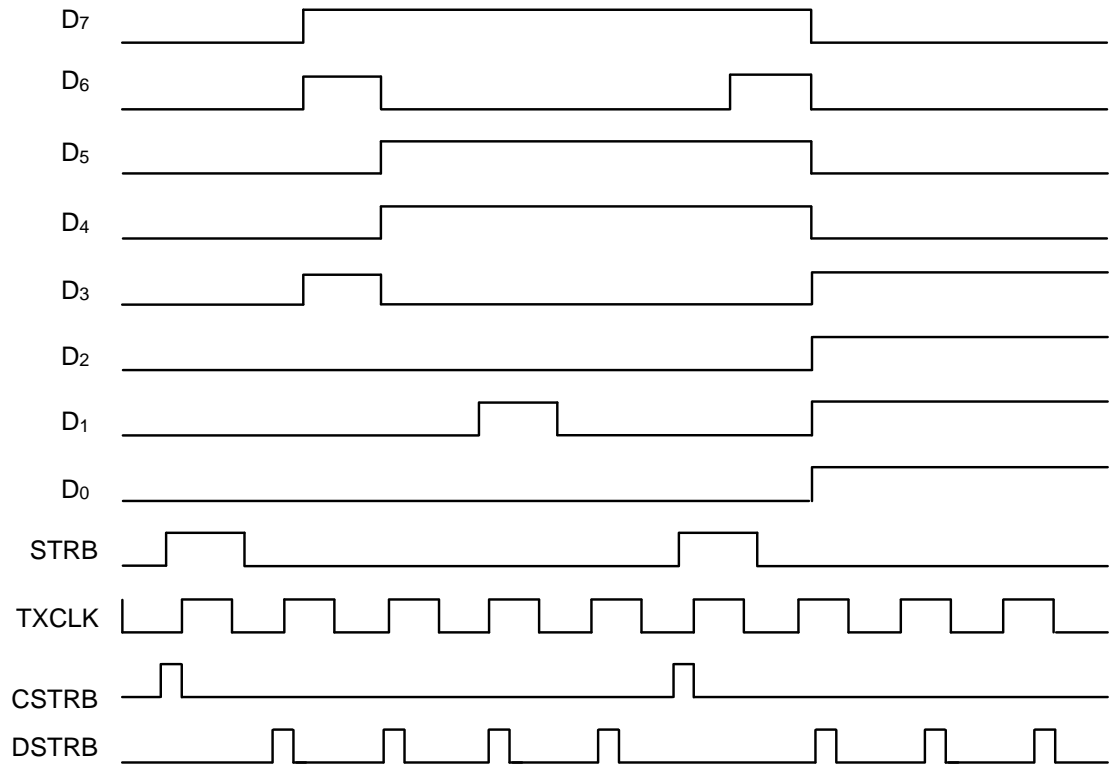

12330E-56

TAXI Technical Information Publication #89-15

Subject: General Device Information for 125/175 MHz TAXI chips
 This T.I.P. provides general information about the design and manufacturing of the 125 MHz and 175 MHz TAXI chips. The information is separated into three categories: Design, Wafer Fab, and Assembly/Packaging.

Design:

	Transmitter (TX)		Receiver (RX)		
Product P/N:	Am7968-125 Am7968-175		Am7969-125 Am7969-175		
Die Number:	4768		4769		
Chip Dimensions:	170 x 167 mils ²		196 x 187 mils ²		
# NPN Transistors:	3386		4384		
# PNP Transistors:	14		24		
# Resistors:	2504		3556		
# Diodes:	87		76		
Equiv. Gate Count:	595		720		
I/O Schematics:	See TAXI TIP #89-12				
Supply Currents:	Typical Values (mA), V _{CC} = 5.5 V Process=Nominal, CD 028 package, Temp. forced with moving air flow (approx. theta _{JMA} = 20°C/W)				
	-55°C	0°C	25°C	70°C	125°C
Transmitter:	230	215	203	187	178
Receiver:	272	250	237	212	182

Wafer Fab:

Location:	Fab 2A, San Antonio, TX (formerly Fab 11) Process ID: Bipolar IMOX-S2: 402L-1156
Metal One:	TiW (barrier metal): 1800 A nom. thickness AlCu: 1.0% Cu, 8000 A nom. thickness Pitch = 4 μ
Metal Two:	AlCu: 1.0% Cu, 15500 A nom. thickness Pitch = 8 μ
Passivation:	Silox/Nitride dual layer. 7500 A nominal thickness Nitride: 6800 A nominal thickness

Assembly/Packaging:

	CerDIP (CD 028) LCC (CLT028)	PLCC (PL 028)	
Assembly Location:	Manila	Bangkok	
Ld. Frame Material:	CD: Alloy 42	Copper	
Bond Wire:	1.25 mil Al/Si (1% Si)	1.25 mil Au	
Bonding Method:	Ultrasonic	Ball Bonding	
Die Attach:	Ag Glass	Ag Filled Epoxy	
Molding Compound:	N/A	Sumitomo 6300H	
Lead Finish	CD 028 Comm.:	Tin Plate	
	CD 028 Mil.:	Solder Dip	
	CLT028 Mil.:	Solder Dip	
	PL 028:	Solder Plate	
Thermal Impedance:			
	<u>CD 028¹</u>	<u>CLT028²</u>	<u>PL 028²</u>
θ_{JA} TX :	41°C/W	n/a	53°C/W
RX:	43°C/W	n/a	52°C/W
θ_{JC} TX, RX:	4°C/W	10°C/W	12°C/W

¹ socketed² surface mounted

TAXI Technical Information Publication #89-Nov '89

Subject: TAXIchip Error Rate Example

INTRODUCTION

A method was devised to establish a baseline TAXIchip set error rate. A series of tests were conducted at a transmission rate of 125 MHz at room temperature, and various power supply voltages. The data collected will be used to determine fiber optic and wire interconnect BER (Bit Error Rate) tests to be completed at a later date.

METHOD

The test method used the TAXI Transmitters and Receivers to transfer data continuously for at least one thousand hours per pair with different V_{CC} conditions. To implement this test, five TAXI K2 boards were used. Each board includes a TAXI Transmitter with a ROM data source, and a Receiver with a ROM data checker to test data integrity on every byte. They were set up according to the diagrams in Figure 20, and interconnected with AC coupled short coax lines.

In Setup 1, a single power supply with 5 V V_{CC} was attached to TAXI K2 board #1. Board #1 ran independently with the SEROUT+/- connected to its SERIN+/- with 50 Ω coaxial cables.

Setup 2 had oscillating voltages (4 V to 6 V) connected to the V_{CC} of TAXI K2 boards #2 and #3. The SEROUT+/- of board #2 were connected to the SERIN+/- of board #3, and the SEROUT+/- of board #3 connected to the SERIN+/- of board #2, with 50 Ω coaxial cables, forming two test setups with continually varying power supply voltages.

Setup 3 also uses two power supplies with one set at 4 V and the other at 6 V. These two power supplies were connected to TAXI K2 boards #4 and #5. The SEROUT+/- and SERIN+/- were connected in the same configuration as boards #2 and #3 in setup 2 with 50 Ω coaxial cables.

The power supply voltages used (4 and 6 V) are outside the data sheet specification for the TAXIchip set. This test was intended to stress the parts and to simulate extreme temperature and operating conditions.

These five boards were checked regularly, and the error counts were recorded. To verify that these boards were still running correctly, they were made to fail intentionally and then reset.

RESULT

The tests were completed after each board ran more than 1,000 hours. The table below summarizes the results.

Board#	Hours	Errors	Notes
1	1,606	0	
2	1,623	8*	Errors occurred between 438–558 hours
3	1,082	0	
4	1,607	2*	Errors occurred between 438–558 hours
5	1,082	0	

* One error can cause multiple error counts. These were assumed to be one error event.

Board #4 failed on another occasion after the errors indicated above, but this failure was due to a power supply failure. Failure time was subtracted from the total run time, and errors were not indicated in the total. Also, boards #2 and #4 ran over 1,000 hours each without any error after the only noted error occurrence.

CONCLUSION

The five sets of TAXI Transmitters and Receivers have run a sum total of 7,000 hours (3.15 x 10¹⁴ bytes) with two error events.

Figure 20 TAXI K2 Board Transmit/Receive Section

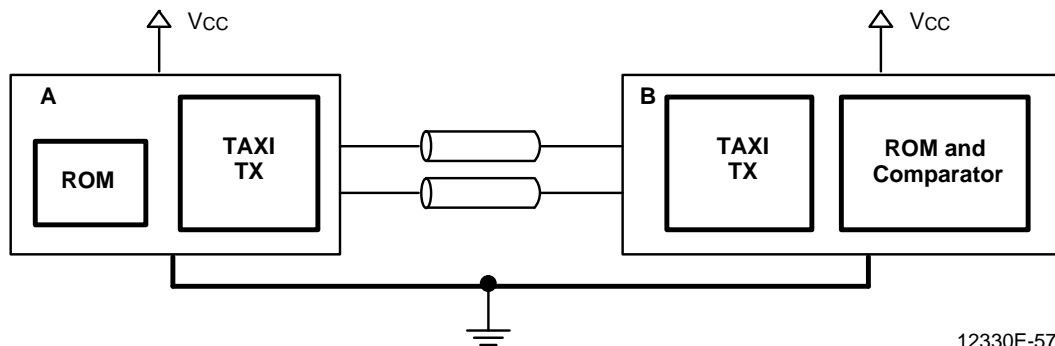

12330E-57

Note:

TAXI K2 board includes both TAXI TX and TAXI RX. Each half may be used independently or with other boards with matching ROM data patterns. For the test described above, FDDI DDJ ROM patterns were used.

V_{cc} Conditions

	TAXI TX	TAXI RX
SETUP 1	5	5
SETUP 2	4-6 Variable 4-6 Variable	4-6 Variable 4-6 Variable
SETUP 3	4 6	6 4

This datasheet has been downloaded from:

www.DatasheetCatalog.com

Datasheets for electronic components.



LittleDiode supplies new, hard to find or obsolete electronic components and semiconductors all over the world.

With over two million different components listed you are sure to find the part you need.

Feel free to visit us today at our online store:

LittleDiode.com

Looking forward to providing you with the best possible service.