

## DRIVING DC MOTORS

By G. MAIOCCHI

### INTRODUCTION

Driving DC motors with integrated circuits seems at first to be rather simple. Yet by analyzing the actual application it is possible to see if there exist conditions causing stresses to the IC during operation which in the end can cause failure. With proper design and analysis in critical applications it is possible to avoid conditions which lead to IC damage.

### GENERAL CONSIDERATIONS

Figure 1 illustrates driving a DC motor using a power MOS bridge.

By driving the four MOS in the correct sequence the direction of current flow through the motor is reversed, consequently reversing the direction of the motor's rotation. The motor torque is a function of

the current amplitude, the motor's internal parameters, and the external load. The resistive torque is dependent on the motor's internal friction. The current level can be controlled with current chopping. The controller checks the current level by monitoring the sense resistor voltage and then drives the appropriate power MOS. On the other hand this means that when current does not flow in the sense resistor (which we will examine during recirculation) it is not possible to measure the current level and thus limit it.

Figure 2 shows a more general application circuit which includes an external control loop. Data relating to the actual motor speed is transmitted to the controller by the system which stabilizes the current in the bridge as a function of the requested rotation velocity. In this case also the current is limited through chopping.

Figure 1.

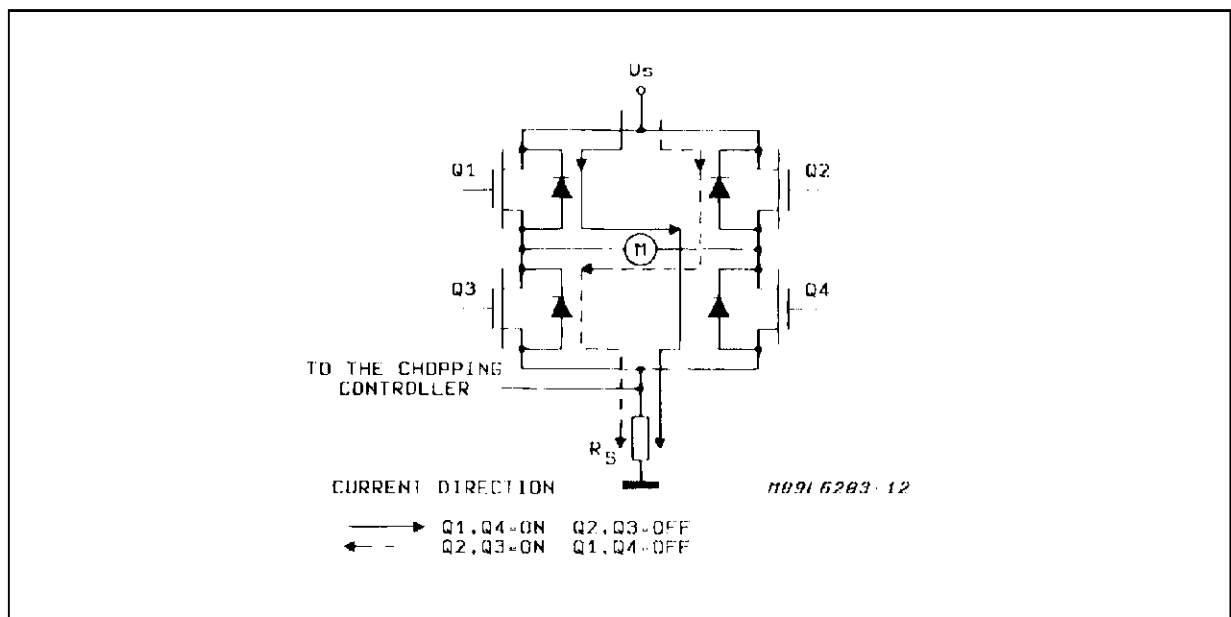

## APPLICATION NOTE

Figure 2.

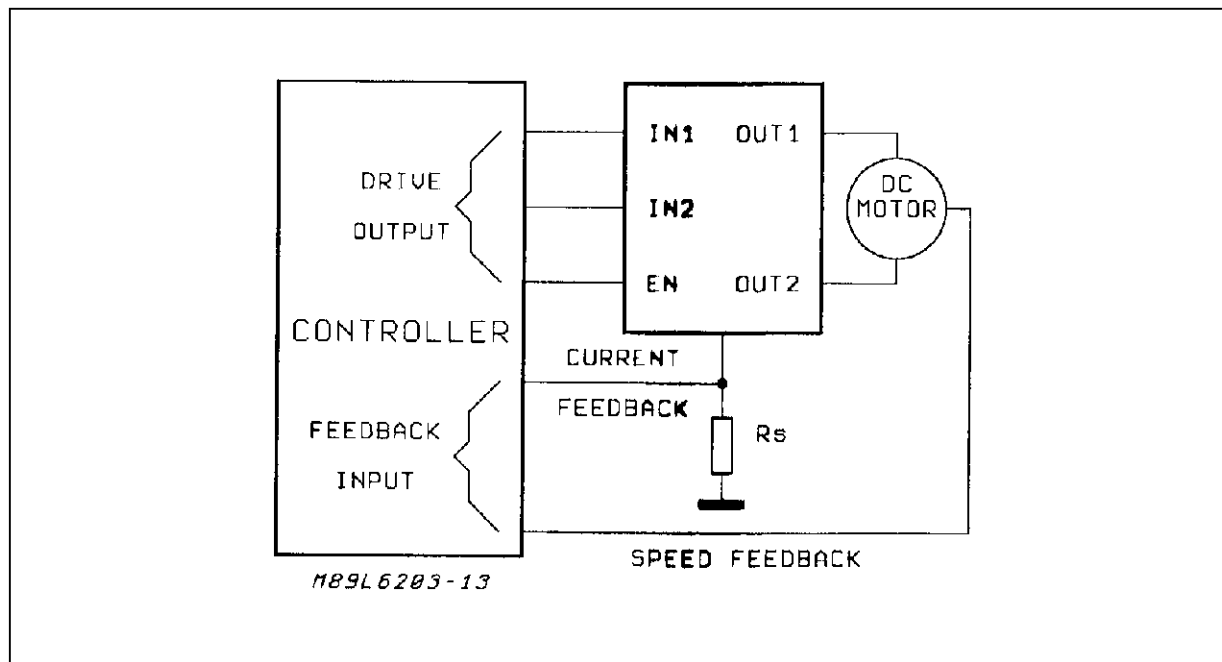

Electrically a DC motor can be viewed as a series RL network with a voltage generator  $V(\omega)$ . The generator represents the back electromotive force (BEMF) generated by the motor's rotation and which opposes the electromotive force of the supply.

The value of the BEMF is a function of the motor's angular velocity. If the motor has no external load and its velocity is not limited, it will accelerate up to the velocity  $w$  such that  $V(w)$  equals the supply voltage  $V_s$ . In this situation the two EMF's cancel each other and thus the motor torque responsible for acceleration will go away. In reality  $V(\omega)$  is always slightly less than  $V_s$  in which case a small motor torque is necessary to compensate resistive torque due to internal friction.

Thus it can be seen that the motor's BEMF can reach elevated values which in some cases can cre-

ate application problems due to a certain type of stress.

### RECIRCULATION CURRENT

Part of the energy delivered to the circuit by the supply is stored in the motor's inductance. When an inductive load is driven, during chopping and during inversion of the diagonal of the bridge, there is always some recirculation current which allows this energy to discharge.

The following figures show the resulting current paths based on the type of chopping method used. In the first two cases, "two-phase" and "enable" chopping, the current decays quickly and, is thus, fast recirculation. When "one-phase" chopping is implemented the current requires a longer time period to decay and, is thus, slow recirculation.

Figure 3a : Two Phase Chopping.

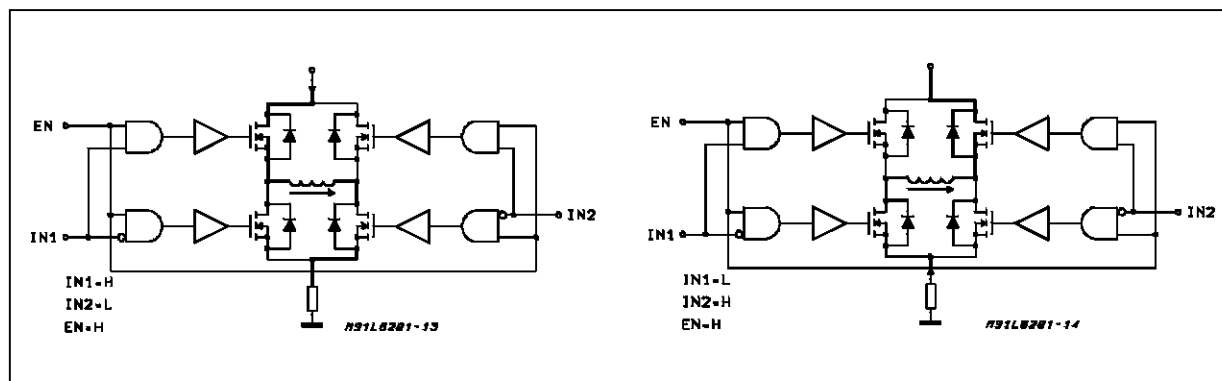

Figure 3b : Enable Chopping.

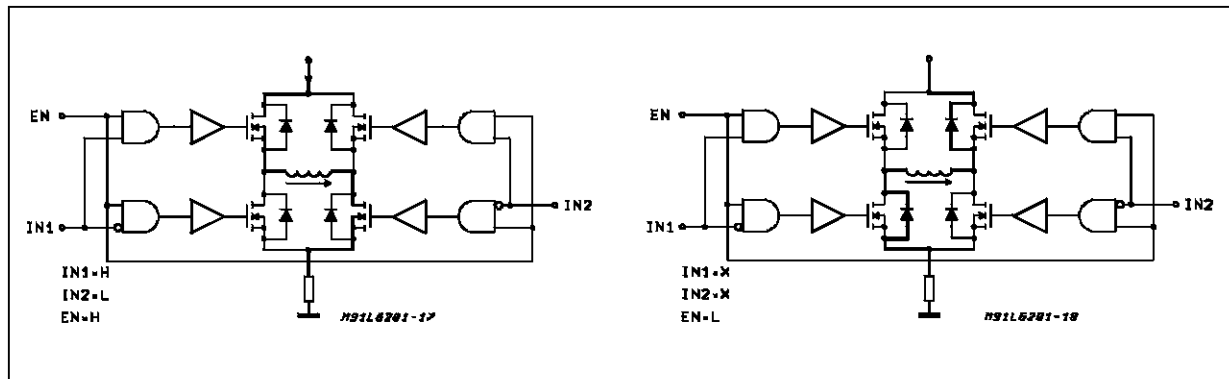
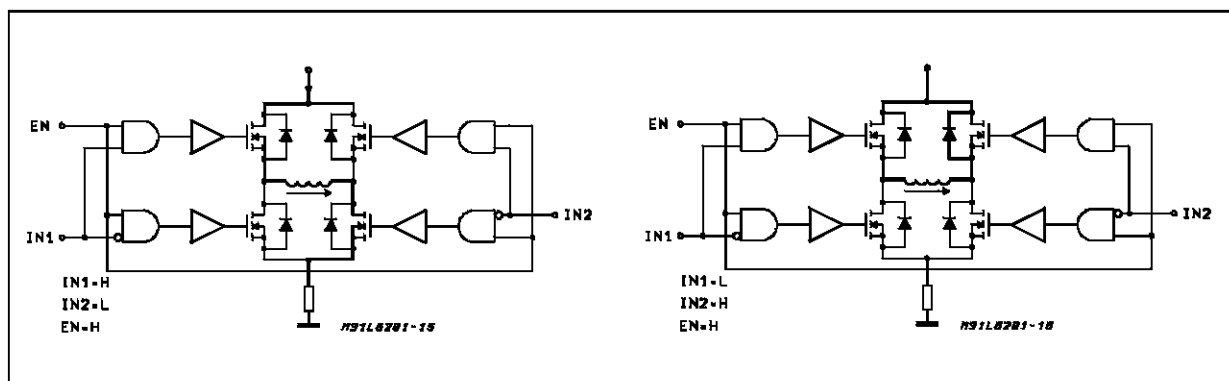

Figure 3c : One Phase Chopping.



## DYNAMIC BEHAVIOUR

The driving of a DC motor will be analyzed dynamically during different motion phases. Fundamental to the working conditions of the IC is the type of load which the motor is driving. In fact if the load is frictional, the deceleration phase is not particularly serious for the IC since the load itself is supplying a braking torque. However, when the load is inertial it will appear to the IC to be a motor torque generator.

This could take the IC into critical operating conditions which can incur failure.

- Acceleration Phase : The current rises, delivering a torque which allows the motor to accelerate, up to the maximum velocity or till it is stabilized by the control loop. The type of load essentially determines the required current.

-Constant Velocity : In this case the required velocity is less than the maximum. The current is limited by chopping. This can be done by turning ON and OFF

a MOS of the diagonal which is in conduction.

- Deceleration : When a DC motor must be decelerated, the type of load being driven becomes important. As previously stated, in the case of a frictional load, the load is essentially braking the motor. Thus, in general, it could be sufficient to cancel the motor torque by opening the bridge (i.e. disable the driver). In the case of an inertial load, however, the braking torque is provided by the driver. It is this situation that is of most concern. Since every change of direction involves a braking phase, a detailed analysis of this situation will be done.

## ROTATION INVERSION

Initially the current flows in one direction as shown in figure 4. Figure 5 illustrates the situation when the diagonal is switched. The motor's inductance discharges the stored energy by fast recirculation through diodes D2 and D3.

## APPLICATION NOTE

Figure 4.

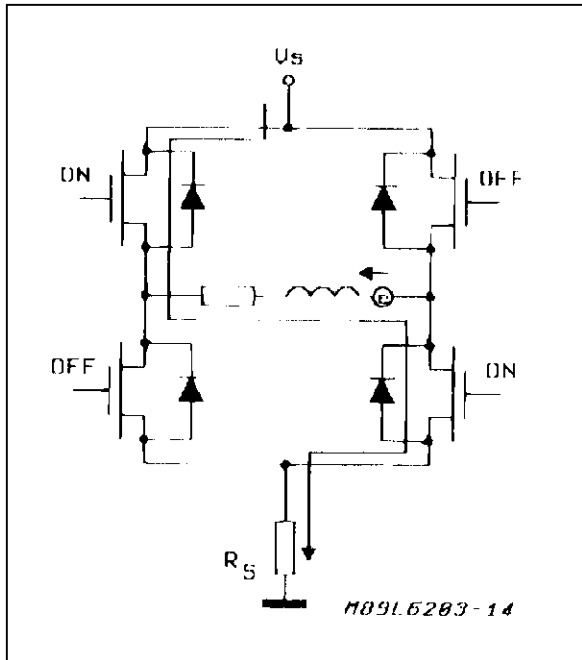

The inertial load of the motor, which can be viewed as a flywheel, has stored energy during the phase prior to inverting the diagonal. This energy is returned to the motor providing a motor torque which keeps the motor rotating. Greater still is the flywheel's moment of inertia, greater than the motor torque that it provides to the motor. The discharge time is longer because the flywheel must discharge its energy. Also associated with the motor's rotation is the BEMF. Thus, in order to stop the motor a brak-

Figure 5.

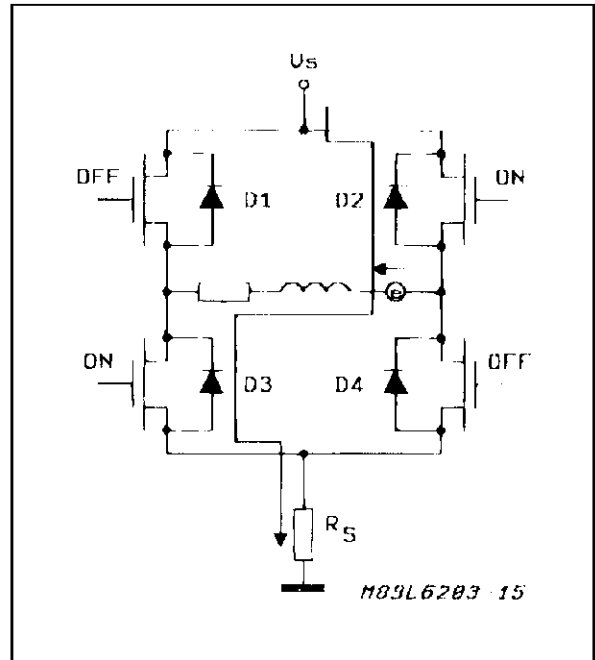

ing torque must be applied. This is generated when, following completion of slow recirculation, the current begins to flow in the opposite direction from the previous state.

It is precisely at this point which effectively the braking phase begins. When the sense voltage rises to the preset level chopping is triggered. In figure 6 chopping results in slow recirculation (in practice the motor is short-circuited).

Figure 6.

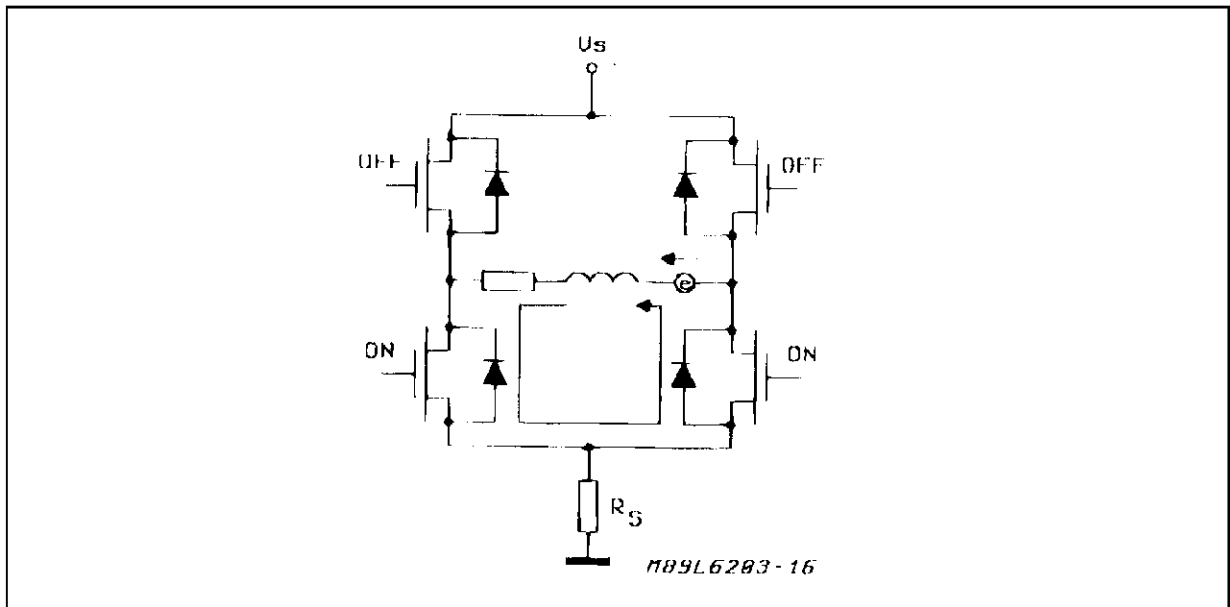

As it can be seen, the BEMF is dropped across the relatively low resistances of the motor, the diode in line and the MOS that is ON. The sense resistor does not enter into this. If the motor's rotational velocity remains high the recirculation current could be very large, enough to damage the IC. Actually the current does not rise instantaneously to the steady state value of  $I = V(\omega)/(R_m + R_d + R_{dson})$ . Rather, the current follows the graph shown in figure 7. In fact, when chopping begins the sense current goes to zero, thus turning MOS M2 ON again. The motor current flows through the sense resistor, re-enabling the chopping.

The cycle repeats in an iterative manner with a recirculation current that continues to rise. Due to the inertial load and the BEMF it generates and the recirculation current as described above, the current in the sense resistor will be greater than the desired value set by  $I_m = V_{ref}/R_{sense}$ . When the current reaches the maximum level (see previous paragraph) the current will fall to the preset level controlled by the chopping, the inertial load having discharged its energy from the previous phase. This elevated current level is temporary, but can be damaging to the IC.

Figure 7.

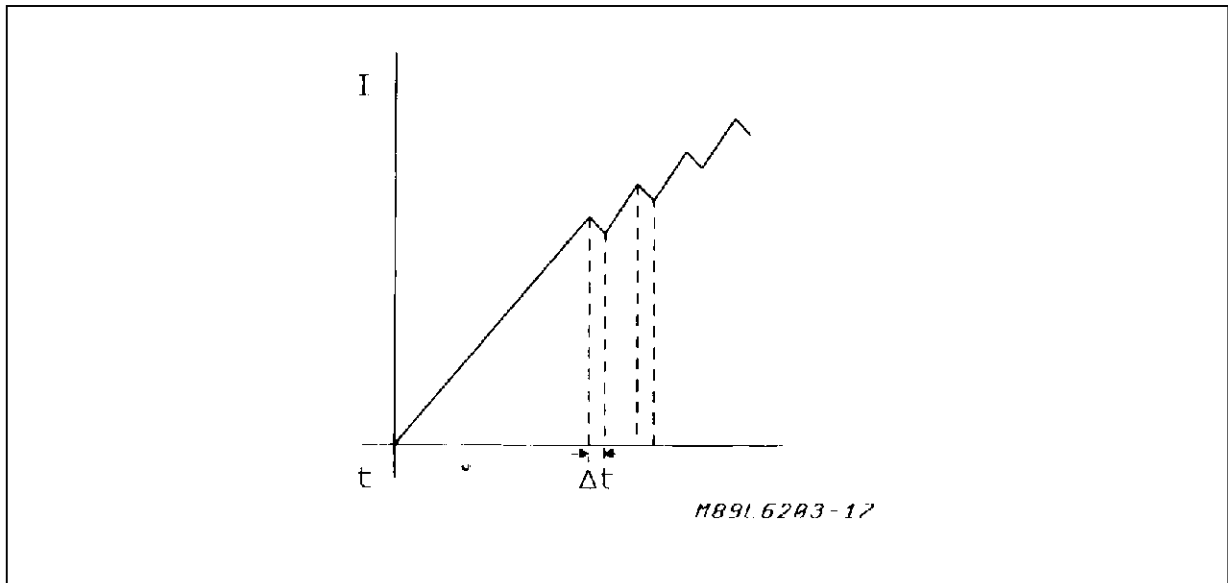

[caption for figure 7]  
 I = recirculation current  
 delta t = time interval during which current flows through Rsense.

Braking the motor by short-circuiting it involves an accurate study of the mechanical system during the design phase. Knowing the value of the BEMF generated by the motor during braking, the motor resistance, and the equivalent resistance of the MOS and

diode involved during recirculation it is possible to determine the recirculation current and if it is less than or greater than the maximum value that the IC can tolerate.

## APPLICATION NOTE

Figure 8.

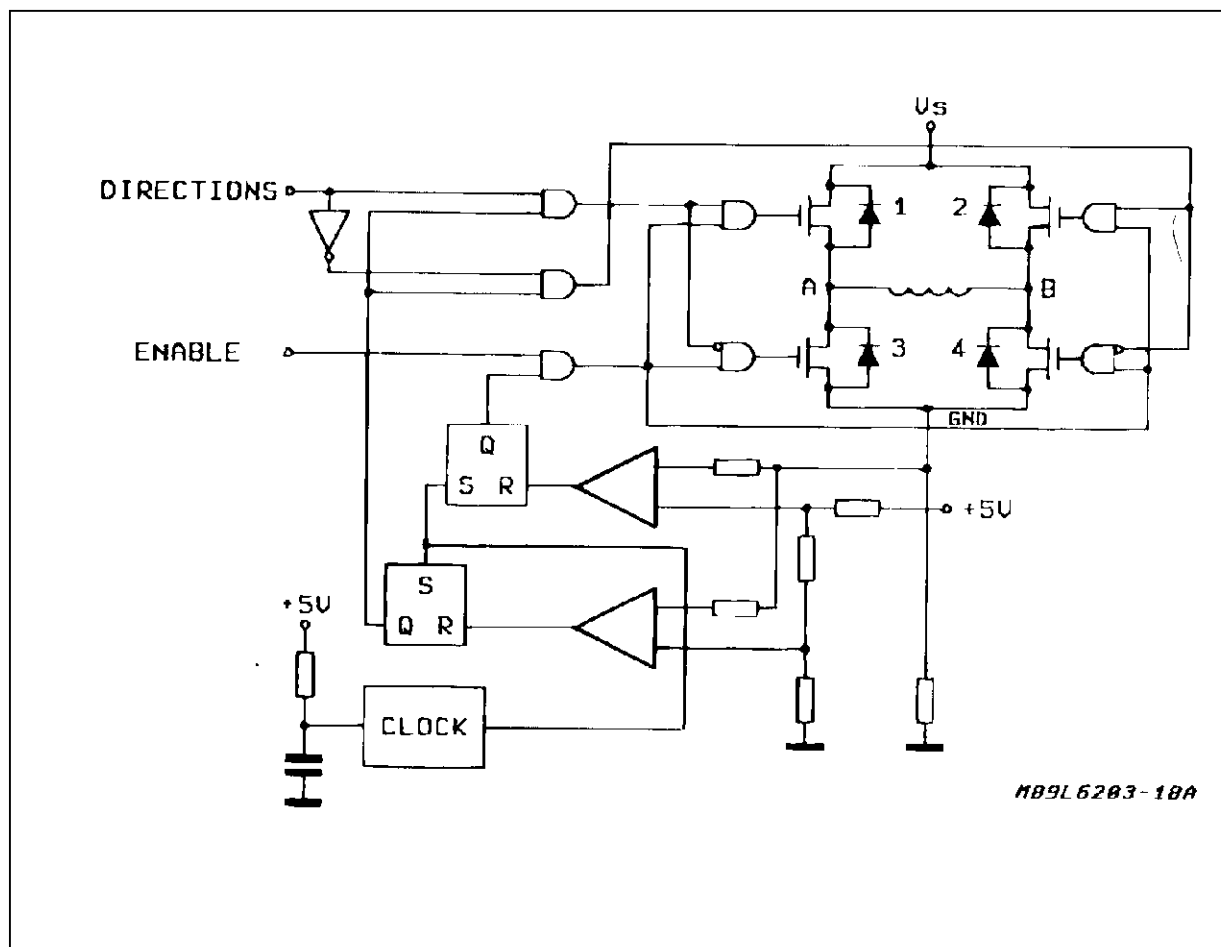

If the recirculation current is too high it will be necessary to brake the motor with an alternative method. Using fast recirculation in combination with slow recirculation it is possible to brake the motor. Even if this is less than an efficient manner it avoids causing damage to the IC due to overcurrent. The basic circuit is shown in figure 8. Figure 9 is the application circuit which the Application Lab of Agrate, experimented with. This circuit uses an L6203 as the power driver. As seen in figure 8, as long as the recirculation current does not reach too high a value slow recirculation is used (one-phase chopping). Above a critical threshold slow recirculation is replaced with fast recirculation achieved by enable chopping. The slow and fast recirculations are triggered by two different reference voltages which determine the two current level thresholds. The higher current level for triggering fast recirculation is set little below the max current level available by the IC.

Figure 10 is the current waveform observed on the oscilloscope during few diagonal inversions. In this figure we can see the general trend of the motor current during three inversions of the rotation. A more detailed view of what really happens to the motor current is shown in fig. 11. Before the rotation inversion the motor is sinking its steady state current (about  $\pm 250\text{mA}$  in this application, the sign depending from the current flow direction). At the rotation inversion, first the current rises, as previous described, to the current level defined by  $I_{ref2}$ . At this moment ENABLE chopping is activated starting the fast recirculation and the current level is clamped at this reference current level. When the motor has dissipated a sufficient rate of its inertial energy, the current falls down, first to the level defined by  $I_{ref1}$  (slow recirculation) for all that interval time that is required to dissipate the remaining inertial energy and then to its steady state working level.

Figure 9.

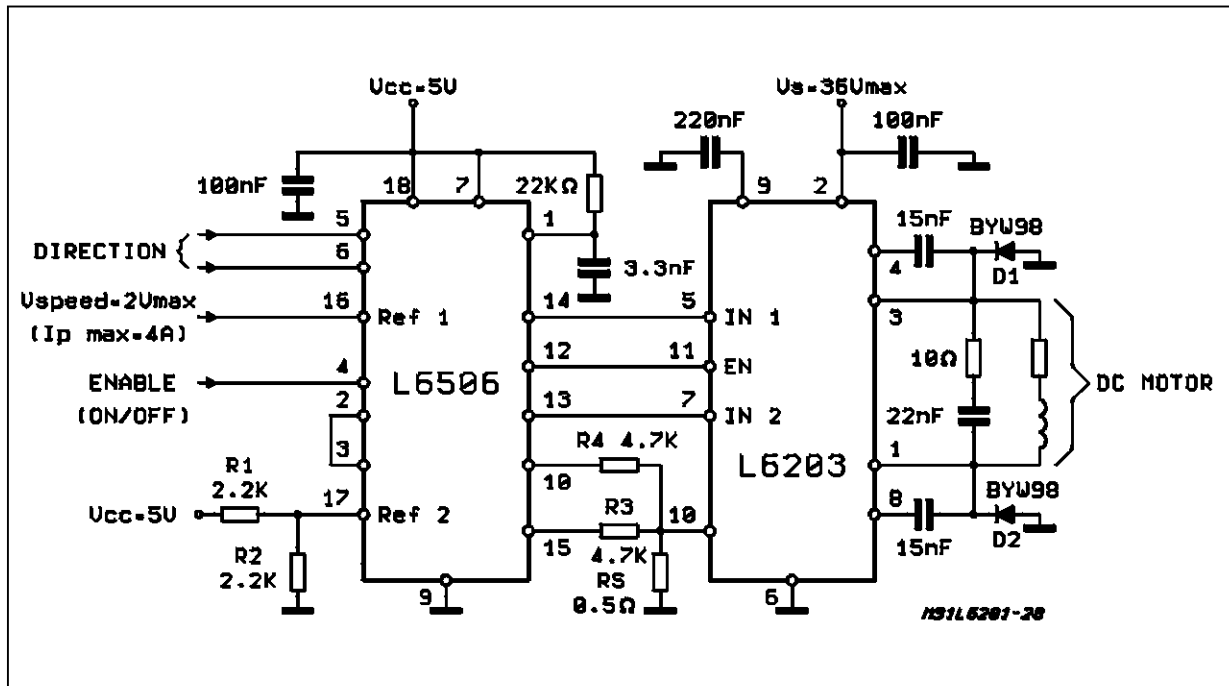
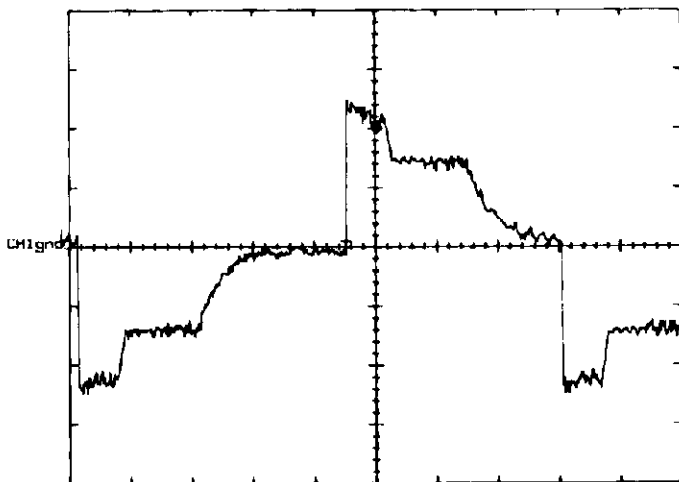

Figure 10.

VERT. 2A/DIV HOR.100ms/DIV



Three diagonal inversion of a unloaded DC motor

This scheme prevents damage to the IC due to overcurrent. However, failure due to overvoltage is still possible. An inertial load will return energy to the supply. If the power supply is the type which cannot sink current but can only source current, then the energy from the motor will load the power supply capacitor to a voltage above  $V_s$ . If the capacitor value is not large enough, during recirculation the capacitor voltage will rise rapidly. Meanwhile, the lower ac-

tive diode is below ground during recirculation. There is a differential voltage between the overvoltage and the point below ground. If this exceeds the absolute maximum voltage of the IC, damage can occur. Overvoltage can be limited with an appropriate value of power supply capacitor. For the below ground condition of the lower diodes, the sources of the upper MOS can be clamped to ground with schottky diodes.

## APPLICATION NOTE

When  $V_s$  is relatively low it may be sufficient to control the differential voltage drop by just limiting the overvoltage with the power supply capacitor and not

having to use the schottky diodes. The feasibility of this solution should nevertheless be verified experimentally in the specific application.

Figure 11.

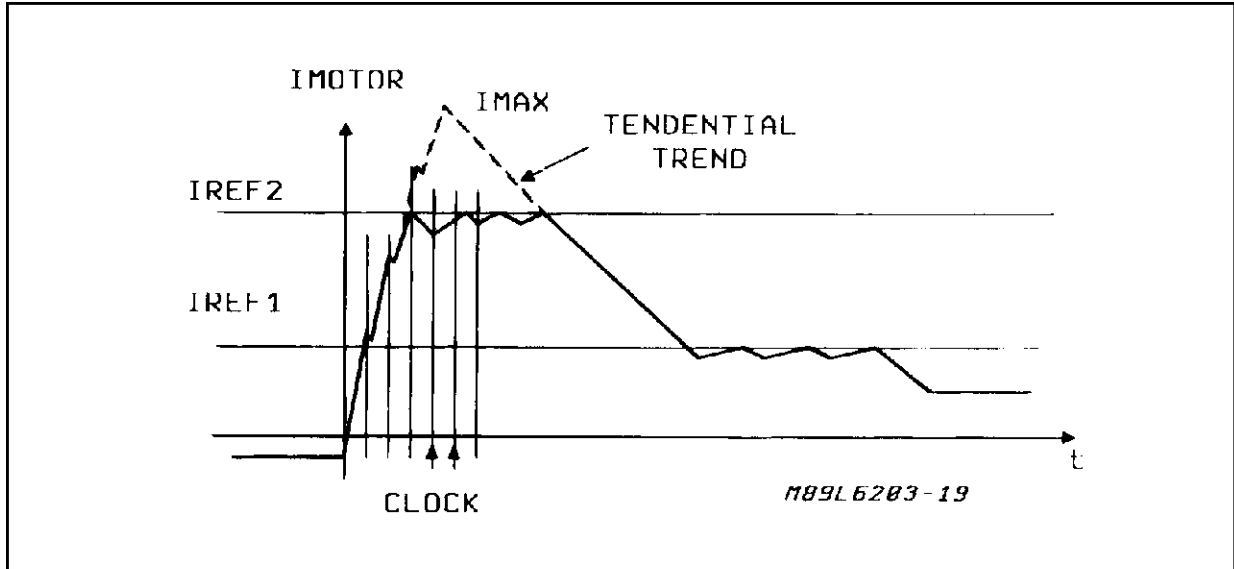

Information furnished is believed to be accurate and reliable. However, SGS-THOMSON Microelectronics assumes no responsibility for the consequences of use of such information nor for any infringement of patents or other rights of third parties which may result from its use. No license is granted by implication or otherwise under any patent or patent rights of SGS-THOMSON Microelectronics. Specifications mentioned in this publication are subject to change without notice. This publication supersedes and replaces all information previously supplied. SGS-THOMSON Microelectronics products are not authorized for use as critical components in life support devices or systems without express written approval of SGS-THOMSON Microelectronics.

© 1995 SGS-THOMSON Microelectronics All Rights Reserved

SGS-THOMSON Microelectronics GROUP OF COMPANIES

Australia - Brazil - France - Germany - Hong Kong - Italy - Japan - Korea - Malaysia - Malta - Morocco - The Netherlands - Singapore - Spain - Sweden - Switzerland - Taiwan - Thailand - United Kingdom - U.S.A.



LittleDiode supplies new, hard to find or obsolete electronic components and semiconductors all over the world.

With over two million different components listed you are sure to find the part you need.

Feel free to visit us today at our online store:

[LittleDiode.com](http://LittleDiode.com)

Looking forward to providing you with the best possible service.