

# AN3224K

## Recording Amplifier Circuit for Video Signal (2-Head Type)

### ■ Outline

The AN3224K is an integrated circuit designed for recording amplifier circuit for video signal (4-head type).

### ■ Features

- Constant current output amplifier
- Built-in current emphasis function
- Built-in switching transistor
- Supply voltage :  $V_{cc}=12V$

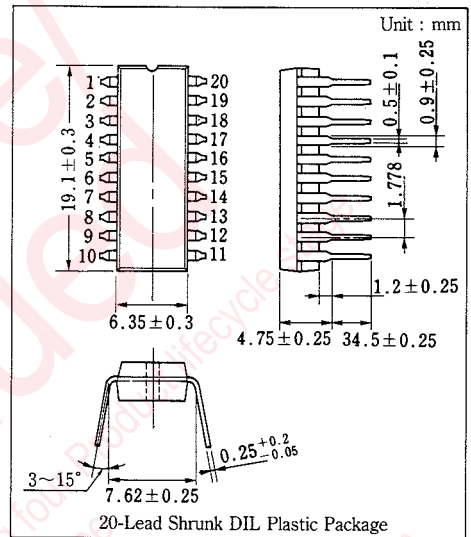

### ■ Block Diagram

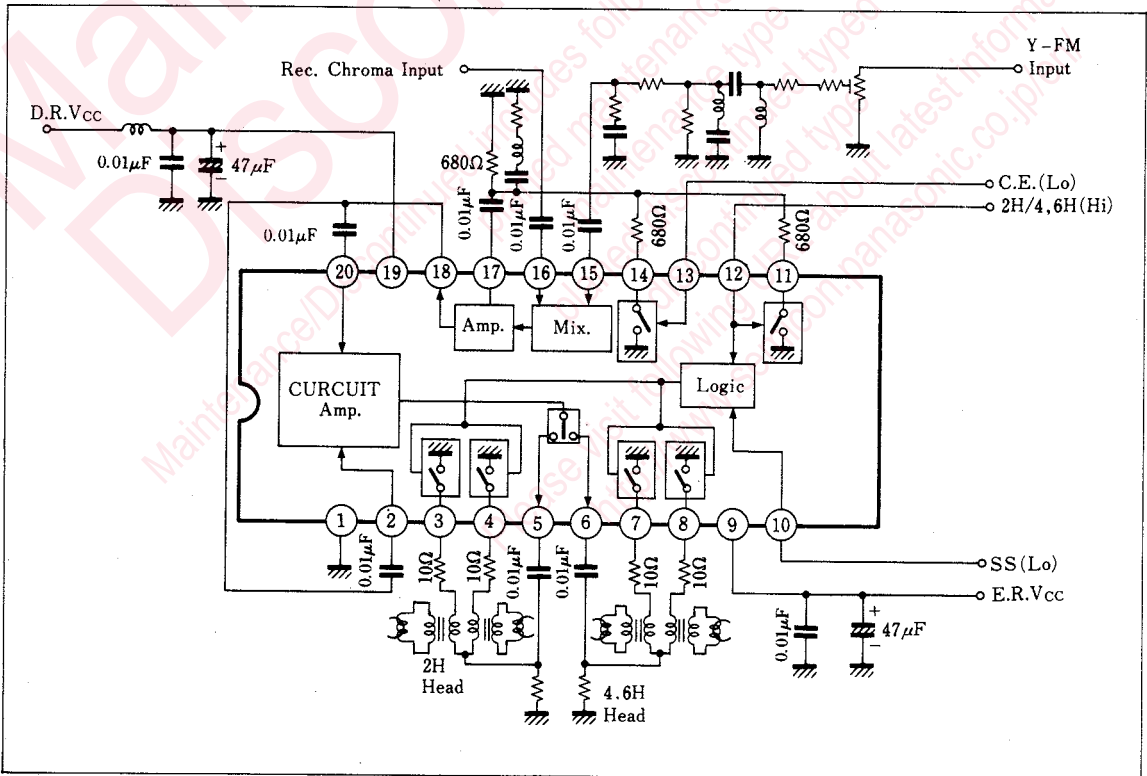

### ■ Pin

Pin No.	Pin Name	Pin No.	Pin Name
1	GND	11	2 H(SP)/4, 6 H(LP)Switch
2	Current Amp. Input(NPN)	12	2 H(SP)/4, 6 H(LP)Changeover
3	Switching Tr. (1)	13	Current Emphasis Changeover
4	Switching Tr. (2)	14	Current Emphasis switch
5	Recording Current Output(SP)	15	Recording FM Signal Input
6	Recording Current Output(LP)	16	Recording Chroma Signal Input
7	Switching Tr. (3)	17	Gain Changeover Amp. Control
8	Switching Tr. (4)	18	Gain Changeover Amp. Output
9	Except Rec. $V_{CC}$	19	Delayed Rec. $V_{CC}$
10	SS Changeover	20	Current Amp. Input(PNP)

### ■ Absolute Maximum Ratings ( $T_a=25^\circ\text{C}$ )

Item	Symbol	Rating	Unit
Supply Voltage	$V_{CC}$	14.4	V
Power Dissipation	$P_D$	700	mW
Operating Ambient Temperature	$T_{opr}$	-20~+70	$^\circ\text{C}$
Storage Temperature	$T_{stg}$	-55~+150	$^\circ\text{C}$

### ■ Electrical Characteristics ( $T_a=25^\circ\text{C}$ )

Item	Symbol	Test Circuit	Condition	min.	typ.	max.	Unit
Circuit Current(REC)	$I_{19}$	1	Delayed Rec. $V_{CC}$ (D.R. $V_{CC}$ )=12V	31		50.5	mA
Circuit Current(PB)	$I_9^{*1}$	2	Except Rec. $V_{CC}$ =5V	9.3		17.5	mA
Recording Current Output(LP)	$I_6$	3	D.R. $V_{CC}$ =12V, $f_{IN}$ =4MHz	7.5		13.1	$\text{mA}_{P-P}/\text{ch}$ .
Recording Current Output(SP)	$I_5$	3	D.R. $V_{CC}$ =12V, $f_{IN}$ =4MHz	15.8		24.2	$\text{mA}_{P-P}/\text{ch}$ .
Chroma Recording Current Output	$I_{5-C}$	3	D.R. $V_{CC}$ =12V, $f_{IN}$ =4MHz	6.2		14	$\text{mA}_{P-P}/\text{ch}$ .
2H(SP)/4,6H(LP)Changeover Voltage	$V_{13}$	4	D.R. $V_{CC}$ =12V			2	V
Current Emphasis Changeover Voltage	$V_{12}$	4	D.R. $V_{CC}$ =12V			2	V
SS Changeover Voltage	$V_{10}$	5	E.R. $V_{CC}$ =5V			3	V
Switching Tr. ON Voltage(1)	$v_3^{*2}$	6	D.R. $V_{CC}$ =12V, $f_{IN}$ =4MHz	25		150	$\text{mV}_{P-P}$
Switching Tr. ON Voltage(2)	$v_4^{*2}$	6	D.R. $V_{CC}$ =12V, $f_{IN}$ =4MHz	25		150	$\text{mV}_{P-P}$
Switching Tr. ON Voltage(3)	$v_7^{*2}$	6	D.R. $V_{CC}$ =12V, $f_{IN}$ =4MHz	10		135	$\text{mV}_{P-P}$
Switching Tr. ON Voltage(4)	$v_8^{*2}$	6	D.R. $V_{CC}$ =12V, $f_{IN}$ =4MHz	10		135	$\text{mV}_{P-P}$
Recording Current Secondary Distortion(LP)	$D_6^{*2}$	7	D.R. $V_{CC}$ =12V			-28	dB
Recording Current Secondary Distortion(SP)	$D_5^{*2}$	7	D.R. $V_{CC}$ =12V			-28	dB
Cross-modulation Relative Level(LP)	$D_{6\pm f}^{*2}$	7	D.R. $V_{CC}$ =12V			-35	dB
Cross-modulation Relative Level(SP)	$D_{5\pm f}^{*2}$	7	D.R. $V_{CC}$ =12V			-35	dB
Recording Current Rated Current Characteristics	$I_5'/I_t^{*2}$	7	D.R. $V_{CC}$ =12V	-0.8		0.8	dB

Note : Operating Supply Voltage Range :  $V_{CC(opp)}=11.0\sim 12.5\text{V}$

\*1. Pin⑨ is EXCEPT REC.  $V_{CC}$  terminal and 5V is used. When the voltage is simultaneously applied to Pins⑨ and ⑩, ICs may be destroyed.

\*2. It is a reference value for design but not a guaranteed value.

Test Circuit 1 ( $I_{19}$ )

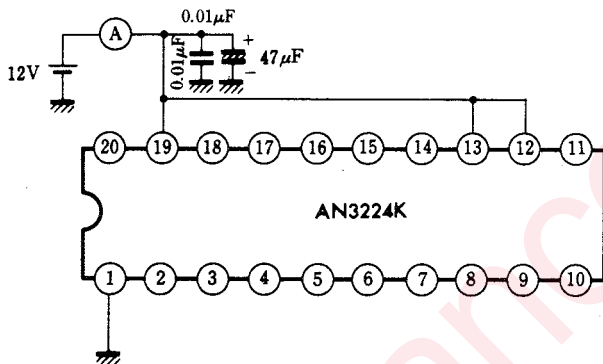

Measure the current which flows to the ammeter at the circuit above.

Test Circuit 2 ( $I_9$ )

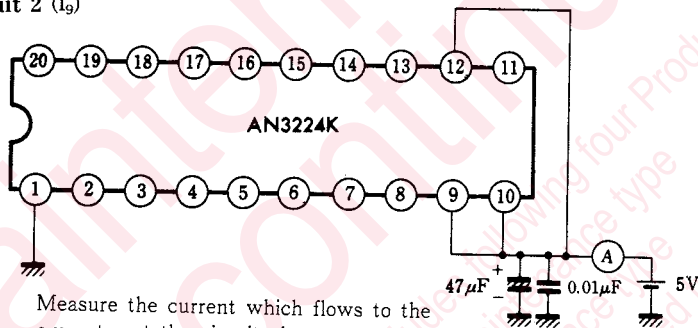

Measure the current which flows to the ammeter at the circuit above.

Test Circuit 3 ( $I_6$ ,  $I_5$ ,  $I_{5-c}$ )

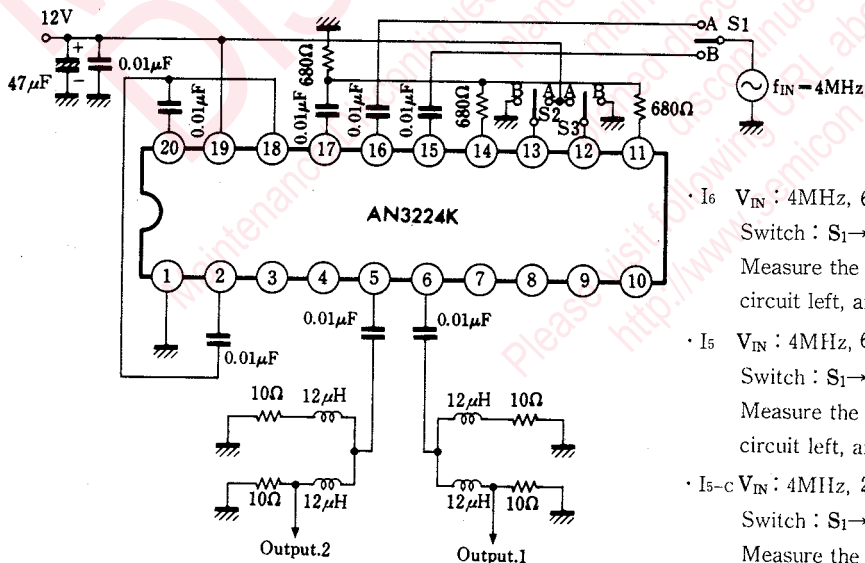

- $I_6$   $V_{IN} : 4\text{MHz}, 60\text{mV}_{P-P}$   $V_{CC} : 12\text{V}$   
Switch :  $S_1 \rightarrow B, S_2 \rightarrow A, S_3 \rightarrow A$   
Measure the voltage of output 1 at the circuit left, and divide it by  $10 \Omega$ .
- $I_5$   $V_{IN} : 4\text{MHz}, 60\text{mV}_{P-P}$   $V_{CC} : 12\text{V}$   
Switch :  $S_1 \rightarrow B, S_2 \rightarrow A, S_3 \rightarrow B$   
Measure the voltage of output 2 at the circuit left, and divide it by  $10 \Omega$ .
- $I_{5-c}$   $V_{IN} : 4\text{MHz}, 240\text{mV}_{P-P}$   $V_{CC} : 12\text{V}$   
Switch :  $S_1 \rightarrow A, S_2 \rightarrow A, S_3 \rightarrow B$   
Measure the voltage of output 2 at the circuit left, and divide it by  $10 \Omega$ .

Test Circuit 4 ( $V_{13}$ ,  $V_{12}$ )

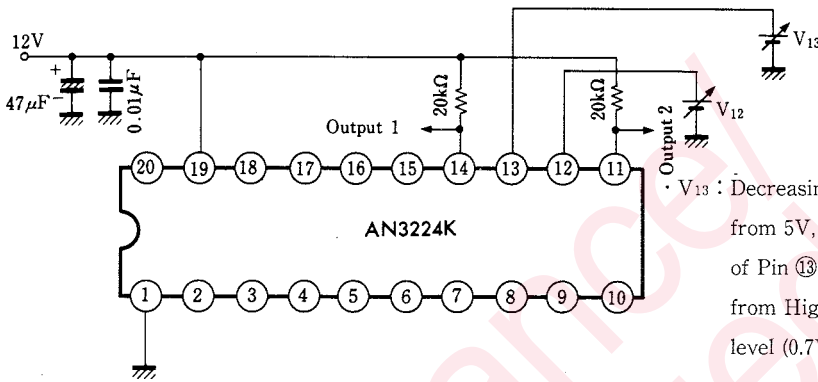

- $V_{13}$ : Decreasing the electric potential of Pin ⑬ from 5V, measure the electric potential of Pin ⑬ when Pin ⑭ output is switched from High level (11V or more) to Low level (0.7V or less).
- $V_{12}$ : Decreasing the electric potential of Pin ⑫ from 5V, measure the electric potential of Pin ⑫ when Pin ⑪ output is switched from High level (11V or more) to Low level (0.7V or less).

Test Circuit 5 ( $V_{10}$ )

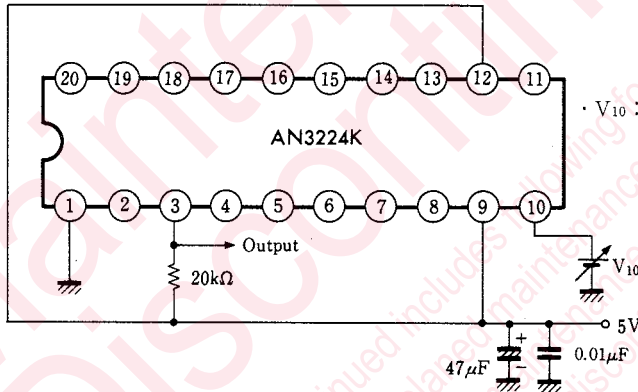

- $V_{10}$ : Increasing the electric potential of Pin ⑩ from 0V, measure the electric potential of Pin ⑩ when Pin ③ output is switched from High level (4.2V or more) to Low level (0.6V or less).

Test Circuit 6 ( $v_3$ ,  $v_4$ ,  $v_7$ ,  $v_8$ )

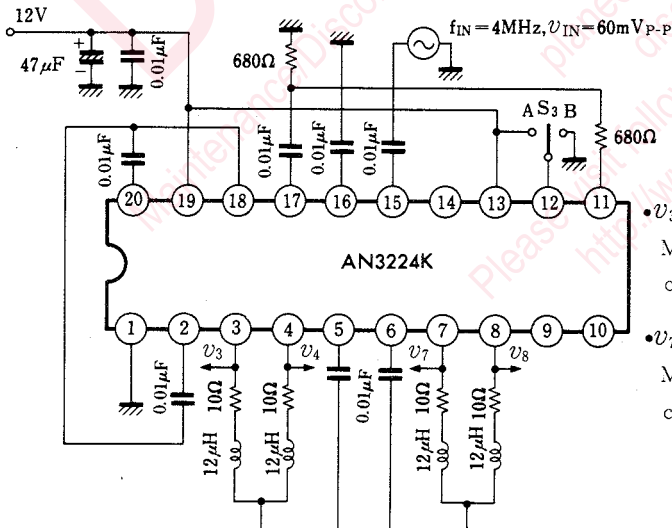

- $v_3$ ,  $v_4$ : (Switch condition :  $S_3 \rightarrow B$ )  
Measure signal voltages of  $v_3$  and  $v_4$  at the circuit shown left.
- $v_7$ ,  $v_8$ : (Switch condition :  $S_3 \rightarrow B$ )  
Measure signal voltages of  $v_7$  and  $v_8$  at the circuit shown left.

Test Circuit 7 ( $D_6$ ,  $D_5$ ,  $D_{6\pm f}$ ,  $D_{5\pm f}$ ,  $I_5/I_5'$ )

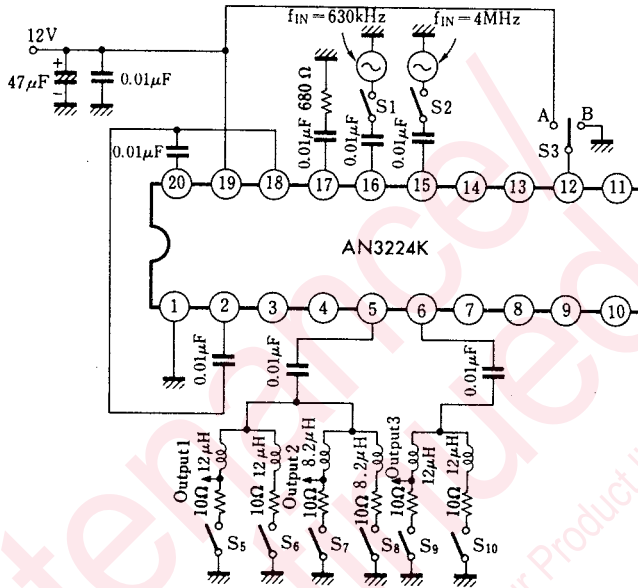

- $D_6$  : (Switch condition :  $S_3 \rightarrow A$ ,  $S_2, S_9, S_{10} \rightarrow$ Short - circuit, Other switches  $\rightarrow$ Open)  
After monitoring a waveform at Output 3, set the recording current to be  $12\text{mA}_{P-P}/\text{Ch}$ . and then measure that secondary distortion with a spectrum analyzer.
- $D_5$  : (Switch condition :  $S_3 \rightarrow B$ ,  $S_2, S_5, S_8 \rightarrow$ Short - circuit, Other switches  $\rightarrow$ Open)  
After monitoring a waveform at Output 1, set the recording current to be  $12\text{mA}_{P-P}/\text{Ch}$ . and then measure that secondary distortion with a spectrum analyzer.
- $D_{6\pm f}$  : (Switch condition :  $S_3 \rightarrow A$ ,  $S_9, S_{10} \rightarrow$ Short - circuit, Other switches  $\rightarrow$ Open)  
After monitoring a waveform at Output 3, first short - circuit the switch  $S_2$  to set the recording current to be  $12\text{mA}_{P-P}/\text{Ch}$ . Next, open the switch  $S_2$ , while short the switch  $S_1$ , to set the recording current to be  $4\text{mA}_{P-P}/\text{Ch}$ . Under this condition, short - circuit the switch  $S_2$  to measure the cross - modulation at Output 1 with a spectrum analyzer.
- $D_{5\pm f}$  : (Switch condition :  $S_3 \rightarrow B$ ,  $S_5, S_8 \rightarrow$ Short - circuit, Other switches  $\rightarrow$ Open)  
After monitoring a waveform at Output 1, first short - circuit the switch  $S_2$  to set the recording current to be  $12\text{mA}_{P-P}/\text{Ch}$ . Next, open the switch  $S_2$ , while short the switch  $S_1$ , to set the recording current to be  $4\text{mA}_{P-P}/\text{Ch}$ . Under this condition, short - circuit the switch  $S_2$  to measure the cross - modulation at Output 1 with a spectrum analyzer.
- $I_5'/I_5$  : (Switch condition :  $S_3 \rightarrow B$ ,  $S_2 \rightarrow$ Short - circuit, Other switches  $\rightarrow$ Open)  
After monitoring a waveform at Output 1, first short - circuit the switches  $S_5$  and  $S_9$  to set the recording current to be  $12\text{mA}_{P-P}/\text{Ch}$ . Next, open the switch, while short the switches  $S_7$ , and  $S_8$ , to measure the recording current  $I_5'$  at Output 2.

(Reference)

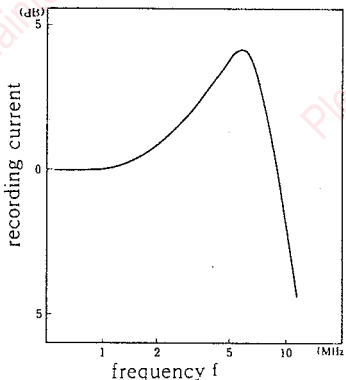

An example of the frequency characteristics of recording current at Test Circuit 7

This characteristics varies depending on ICs.

Therefore, use ICs under the sufficient damping condition of a resonance peak.

## Request for your special attention and precautions in using the technical information and semiconductors described in this book

- (1) If any of the products or technical information described in this book is to be exported or provided to non-residents, the laws and regulations of the exporting country, especially, those with regard to security export control, must be observed.
- (2) The technical information described in this book is intended only to show the main characteristics and application circuit examples of the products. No license is granted in and to any intellectual property right or other right owned by Panasonic Corporation or any other company. Therefore, no responsibility is assumed by our company as to the infringement upon any such right owned by any other company which may arise as a result of the use of technical information described in this book.
- (3) The products described in this book are intended to be used for standard applications or general electronic equipment (such as office equipment, communications equipment, measuring instruments and household appliances).  
Consult our sales staff in advance for information on the following applications:
  - Special applications (such as for airplanes, aerospace, automobiles, traffic control equipment, combustion equipment, life support systems and safety devices) in which exceptional quality and reliability are required, or if the failure or malfunction of the products may directly jeopardize life or harm the human body.
  - Any applications other than the standard applications intended.
- (4) The products and product specifications described in this book are subject to change without notice for modification and/or improvement. At the final stage of your design, purchasing, or use of the products, therefore, ask for the most up-to-date Product Standards in advance to make sure that the latest specifications satisfy your requirements.
- (5) When designing your equipment, comply with the range of absolute maximum rating and the guaranteed operating conditions (operating power supply voltage and operating environment etc.). Especially, please be careful not to exceed the range of absolute maximum rating on the transient state, such as power-on, power-off and mode-switching. Otherwise, we will not be liable for any defect which may arise later in your equipment.
  - Even when the products are used within the guaranteed values, take into the consideration of incidence of break down and failure mode, possible to occur to semiconductor products. Measures on the systems such as redundant design, arresting the spread of fire or preventing glitch are recommended in order to prevent physical injury, fire, social damages, for example, by using the products.
- (6) Comply with the instructions for use in order to prevent breakdown and characteristics change due to external factors (ESD, EOS, thermal stress and mechanical stress) at the time of handling, mounting or at customer's process. When using products for which damp-proof packing is required, satisfy the conditions, such as shelf life and the elapsed time since first opening the packages.
- (7) This book may be not reprinted or reproduced whether wholly or partially, without the prior written permission of our company.



LittleDiode supplies new, hard to find or obsolete electronic components and semiconductors all over the world.

With over two million different components listed you are sure to find the part you need.

Feel free to visit us today at our online store:

**[LittleDiode.com](http://LittleDiode.com)**

Looking forward to providing you with the best possible service.