

AN5043

TV/VCR Tuner Band Switch Circuit

■ Description

The AN5043 is an integrated circuit designed for tuner control circuit of TV/VCR electronic tuning system using a semiconductor memory.

■ Features

- Built-in reference voltage stabilizer for electronic tuning
- 2-input, 4-output band switch
- Usable for every tuner with suitable output combination
- Consists of peripheral part of electronic tuning system with semiconductor memory

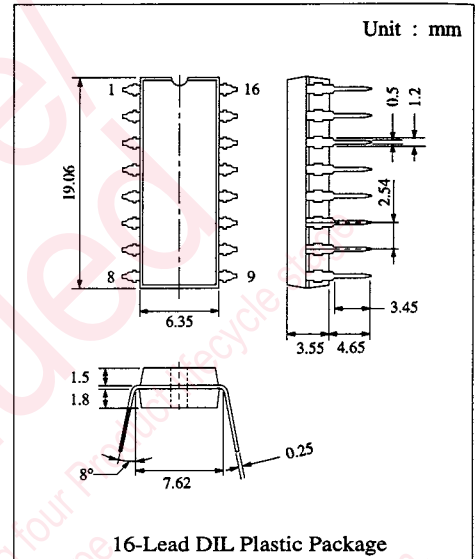

■ Block Diagram

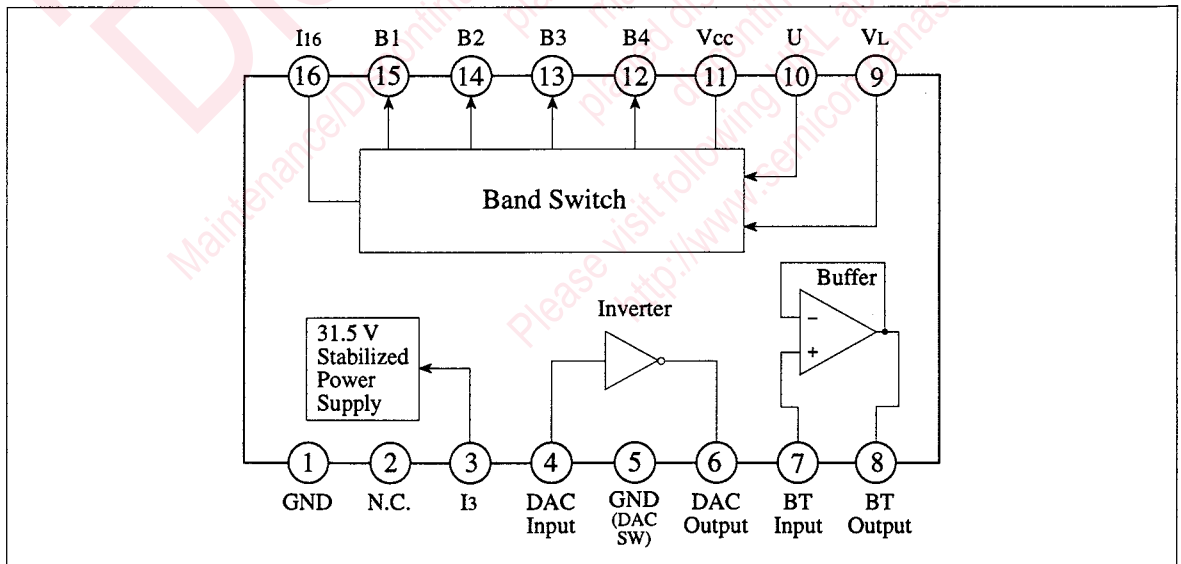

■ Absolute Maximum Ratings (Ta=25°C)

Item	Symbol	Rating	Unit
Supply Voltage	Vcc	14.4	V
Supply Current	Icc	15	mA
Power Dissipation (Ta=70°C)	Pd	700	mW
Operating Ambient Temperature	Topr	-20 ~ +70	°C
Storage Temperature	Tstg	-55 ~ +150	°C

■ Recommended Operating Range (Ta=25°C)

Item	Symbol	Range
Operating Supply Voltage Range	Vcc	9.6V ~ 14.4V
Operating Supply Current Range	I16	2.7mA ~ 5.0 mA
Operating Supply Current Range	I3	6.0 mA ~ 15.0 mA

■ Electrical Characteristics (Ta=25°C)

Item	Symbol	Condition	min.	typ.	max.	Unit
Circuit Current Pin 3	I3	V3-1 = 26V	1.5	2.3	3.1	mA
Circuit Current Pin 11	I11	V11-1 = 12V	2.6	4.0	5.4	mA
DAC IN Input Threshold Voltage	VTH (4)	V5-1 = 0V	0.45	0.7	1.0	V
DAC OUT Output Voltage	V6-1	V4-1 = 1.0V		0.1	0.4	V
DAC OUT Output Voltage	V3-6	V4-1 = 0.45V		0.2	0.7	V
DAC OUT Output Current	I6	V4-1 = 0V	-1.8	-1.1	-0.7	mA
BT IN Input Current	I7	V7-1 = 1 ~ 26V	-0.3	-0.1	0.1	μA
BT OUT "L" Output Voltage	V8-1 L	V7-1 = 0V	0	0.1	0.4	V
BT OUT "H" Output Voltage	V8-3 H	V7-1 = V3-1	-1.5	-1.0	-0.5	V
BT IN-OUT Difference Voltage	V7-8	V7-1 = 1 ~ 26V	0	0.2	0.4	V
Pin Voltage VL	V9-1	V11-1 = 12V	3	3.4	3.8	V
Pin Voltage U	V10-1	V11-1 = 12V	1.7	2.1	2.5	V
VL Input Threshold Voltage	VTH (9)	V11-1 = 12V	0.5		2.0	V
VL Input Threshold Current	ITH (9)	V11-1 = 12V	-500		-50	μA
U Input Threshold Voltage	VTH (10)	V11-1 = 12V	0.5		1.5	V
U Input Threshold Current	ITH (10)	V11-1 = 12V	-500		-50	μA
Output Saturation Voltage	V11-12, 13, 14, 15	IOUT = -60mA	0.6	1.0	1.4	V
Output Leakage Current	I12, 13, 14, 15		-10		0	μA
31.5V Stabilized Voltage	V3-1	I3 = 10mA	29.5	31.5	33.5	V
Operating Resistance	γ3	I3 = 6 ~ 15mA		10	25	Ω

■ Description of Test circuit and Test method

No.	Item	Symbol	Measured Pin No.	Pin No.													Note								
				1	2	3	4	5	6	7	8	9	10	11	12	13		14	15	16					
1	Circuit current pin 3	I ₃	3	0V	26V																				
2	Circuit current pin 11	I ₁₁	12	0V	10 mA	0V	0V	15V							12V										
3,5	DAC IN input threshold voltage	V _{TH} (4)	6	0V	10 mA	0.45 V	0V								12V										Pin 6 "H"
3,4	DAC IN input threshold voltage	V _{TH} (4)	6	0V	10 mA	1.0 V	0V								12V										Pin 6 "L"
6	DAC OUT output current	I ₆	6	0V	10 mA	0V	0V	0V							12V										
7	BT IN input current	I ₇	7	0V	10 mA			1V~ 26V							12V										9.1k 45V
8	BT OUT "L" output voltage	V _{8-1 L}	8	0V	10 mA	0V	0V	0V																	*
9	BT OUT "H" output voltage	V _{8-3 H}	8	0V	10 mA	0V	0V	3V																	*
10	BT IN-OUT difference voltage	V ₇₋₈	8	0V	10 mA	0V	0V	1V~ 26V																	*
11	Pin voltage VL	V ₉₋₁	9	0V	10 mA										12V										9.1k 45V
12	Pin voltage U	V ₁₀₋₁	10	0V	10 mA										12V										9.1k 45V
13	VL input threshold voltage	V _{TH} (9)	14	0V	10 mA										0.5 V										Pin 14 "L"
13	VL input threshold voltage	V _{TH} (9)	14	0V	10 mA										2.0 V										Pin 14 "H"

* : A capacitor should be added between pin 8 (0.01μF) and GND.

■ Description of Test circuit and Test method

No.	Item	Symbol	Measured Pin No.	Pin No.																Note
				1	2	3	4	5	6	7	8	9	10	11	12	13	14	15	16	
14	V _L input threshold current	I _{TH} (9)	14	0V	10 mA							12V						9.1k 45V	Pin 14 "H"	
14	V _L input threshold current	I _{TH} (9)	14	0V	10 mA							12V						9.1k 45V	Pin 14 "L"	
15	U input threshold voltage	V _{TH} (10)	14	0V	10 mA					0.5 V		12V						9.1k 45V	Pin 14 "L"	
15	U input threshold voltage	V _{TH} (10)	14	0V	10 mA					1.5 V		12V						9.1k 45V	Pin 14 "H"	
16	U input threshold current	I _{TH} (10)	14	0V	10 mA					-50 μA		12V						9.1k 45V	Pin 14 "H"	
16	U input threshold current	I _{TH} (10)	14	0V	10 mA					-500 μA		12V						9.1k 45V	Pin 14 "L"	
17	Output saturation voltage	V ₁₁₋₁₂	12	0V	10 mA					0V		12V	-60 mA					9.1k 45V		
17	Output saturation voltage	V ₁₁₋₁₃	13	0V	10 mA					0V		12V	-60 mA					9.1k 45V		
17	Output saturation voltage	V ₁₁₋₁₄	14	0V	10 mA							12V		-60 mA				9.1k 45V		
17	Output saturation voltage	V ₁₁₋₁₅	15	0V	10 mA					0V		12V					-60 mA	9.1k 45V		
18	Output leakage current	I _{12,13,15}	12,13,15	0V	10 mA							12V	0V	0V				9.1k 45V		
18	Output leakage current	I ₁₄	14	0V	10 mA							12V			0V			9.1k 45V		
19	3.1.5V stabilized voltage	V ₃₋₁	3	0V	10 mA													9.1k 45V		
20	Operating Resistance	γ ₃	3	0V	6-15 mA															

■ Application Circuit

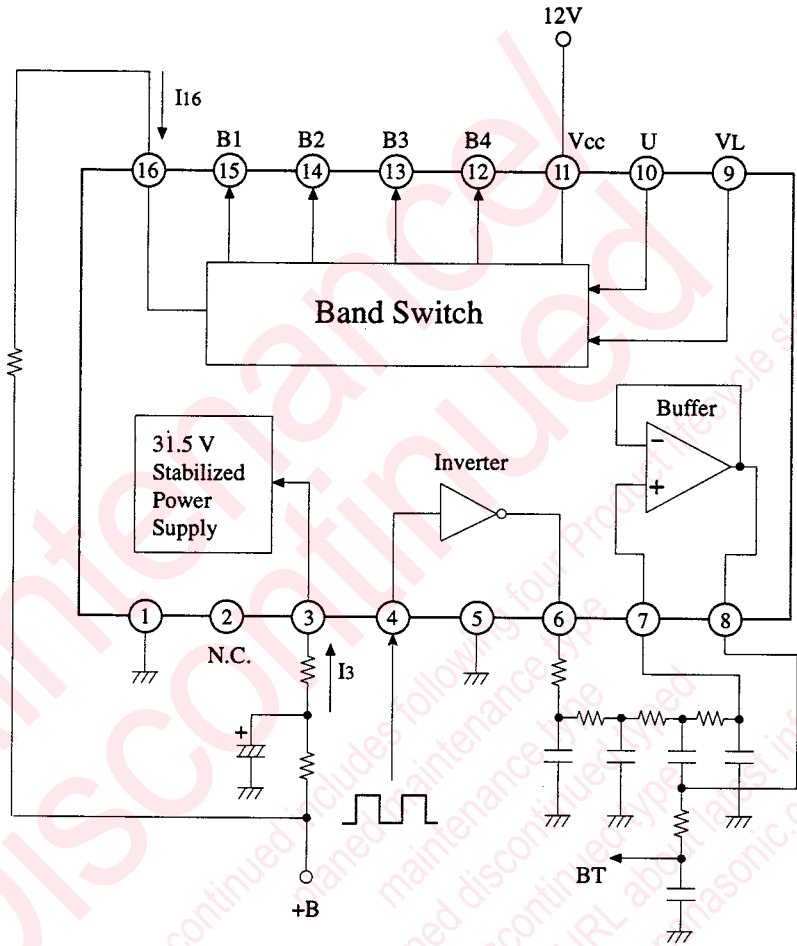

■ Pin Descriptions

Pin No.	Pin Name	Pin No.	Pin Name
1	GND	9	V _L Input
2	N. C.	10	U Input
3	31.5V Stabilized Voltage (I ₃)	11	Supply Voltage V _{cc}
4	DAC Input	12	B4 Output
5	GND (DAC SW)	13	B3 Output
6	DAC Output	14	B2 Output
7	BT Input	15	B1 Output
8	BT Output	16	Supply Current (I ₁₆)

Band Switch I/O Logic

Input Pin		Output Pin				Remarks
⑨	⑩	⑮	⑭	⑬	⑫	
L	H	H	L	L	L	VHF-L
H	H	L	H	L	L	VHF-H
L	L	L	L	H	L	-----
H	L	L	L	L	H	UHF

H/L state of Input pin :

L : 0.5V or less

H : $V_{9-1} > 2.0V$, $V_{10-1} > 1.5V$

H/L state of Output pin :

L : High impedance

H : $V_{CC} - V_{CE}(\text{sat})$

Request for your special attention and precautions in using the technical information and semiconductors described in this book

- (1) If any of the products or technical information described in this book is to be exported or provided to non-residents, the laws and regulations of the exporting country, especially, those with regard to security export control, must be observed.
- (2) The technical information described in this book is intended only to show the main characteristics and application circuit examples of the products. No license is granted in and to any intellectual property right or other right owned by Panasonic Corporation or any other company. Therefore, no responsibility is assumed by our company as to the infringement upon any such right owned by any other company which may arise as a result of the use of technical information described in this book.
- (3) The products described in this book are intended to be used for standard applications or general electronic equipment (such as office equipment, communications equipment, measuring instruments and household appliances).
Consult our sales staff in advance for information on the following applications:
 - Special applications (such as for airplanes, aerospace, automobiles, traffic control equipment, combustion equipment, life support systems and safety devices) in which exceptional quality and reliability are required, or if the failure or malfunction of the products may directly jeopardize life or harm the human body.
 - Any applications other than the standard applications intended.
- (4) The products and product specifications described in this book are subject to change without notice for modification and/or improvement. At the final stage of your design, purchasing, or use of the products, therefore, ask for the most up-to-date Product Standards in advance to make sure that the latest specifications satisfy your requirements.
- (5) When designing your equipment, comply with the range of absolute maximum rating and the guaranteed operating conditions (operating power supply voltage and operating environment etc.). Especially, please be careful not to exceed the range of absolute maximum rating on the transient state, such as power-on, power-off and mode-switching. Otherwise, we will not be liable for any defect which may arise later in your equipment.
 - Even when the products are used within the guaranteed values, take into the consideration of incidence of break down and failure mode, possible to occur to semiconductor products. Measures on the systems such as redundant design, arresting the spread of fire or preventing glitch are recommended in order to prevent physical injury, fire, social damages, for example, by using the products.
- (6) Comply with the instructions for use in order to prevent breakdown and characteristics change due to external factors (ESD, EOS, thermal stress and mechanical stress) at the time of handling, mounting or at customer's process. When using products for which damp-proof packing is required, satisfy the conditions, such as shelf life and the elapsed time since first opening the packages.
- (7) This book may be not reprinted or reproduced whether wholly or partially, without the prior written permission of our company.



LittleDiode supplies new, hard to find or obsolete electronic components and semiconductors all over the world.

With over two million different components listed you are sure to find the part you need.

Feel free to visit us today at our online store:

LittleDiode.com

Looking forward to providing you with the best possible service.