

AN7171NK, AN7176K

Dual BTL 14W Audio Power Amplifier Circuits

■ Overview

The AN7171NK and AN7176K are ICs for power amplification of 14W (13.2V, 4Ω) output. It can provide stereo operation since two BTL amplifiers are incorporated in a chip. It incorporates various protective circuits, thus providing high reliability. The circuits can be turned on or off with supply pins energized, because the stand-by circuit is built-in.

■ Features

- Two BTL 14W outputs built-in
- Stand-by circuit built-in
- Various protective circuits (for temperature, or against over-voltage, short-circuit between output and earth and between output and V_{CC}, load short-circuit)
- Small shock noise at power ON/OFF
- Fewer external components required
- Good oscillation stability

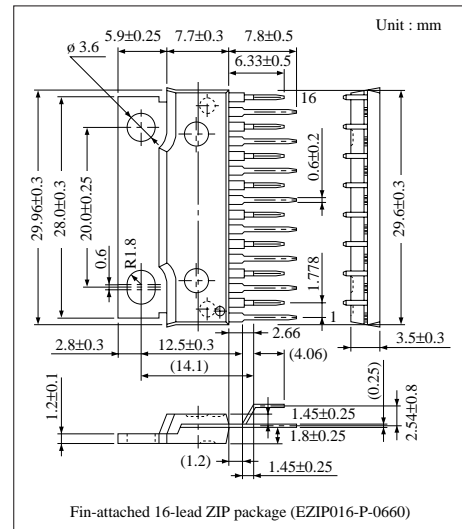

■ Block Diagram

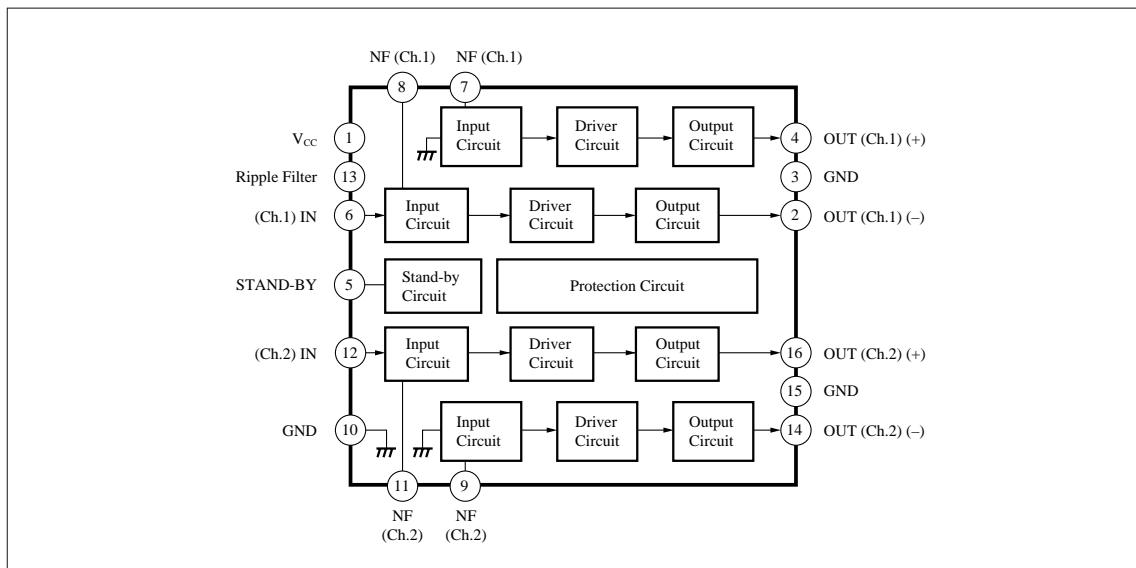

■ Pin Descriptions

Pin No.	Pin Name	Pin No.	Pin Name
1	V _{CC}	9	Negative Feedback Ch.2
2	Output Ch.1 (+)	10	GND (Input)
3	GND (Output Ch.1)	11	Negative Feedback Ch.2
4	Output Ch.1 (-)	12	Input Ch.2
5	Stand-by	13	Ripple Filter
6	Input Ch.1	14	Output Ch.2 (-)
7	Negative Feedback Ch.1	15	GND (Output Ch.2)
8	Negative Feedback Ch.1	16	Output Ch.2 (+)

■ Absolute Maximum Ratings (Ta= 25°C)

Parameter	Symbol	Rating	Unit
Supply Voltage	V _{CC} ^{Note 1)}	24	V
Peak Supply Voltage	V _{CC (surge)} ^{Note 2)}	50.0	V
Supply Current	I _{CC}	6.0	A
Power Dissipation	P _D ^{Note 3)}	37.5 ^{Note 4)}	W
Operating Ambient Temperature	T _{opr}	- 30 ~ + 75	°C
Storage Temperature	T _{stg}	- 55 ~ + 150	°C

Note 1) When no signals

Note 2) Time = 0.2s

Note 3) R_{θj-c} = 2°C/W

Note 4) Ta = 75°C

■ Recommended Operating Range (Ta = 25°C)

Parameter	Symbol	Range
Operating Supply Voltage Range	V _{CC}	8.0V ~ 18.0V

■ Electrical Characteristics (V_{CC} = 13.2V, R_L = 4Ω, f = 1kHz, Ta = 25°C)

Parameter	Symbol	Condition	min.	typ.	max.	Unit	
Quiescent Current	I _{CQ}	V _{in} = 0mV	—	120	200	mA	
Output Noise Voltage ^{Note)}	V _{no}	V _{in} = 0mV, R _g = 10kΩ	—	0.60	1.50	mVrms	
Voltage Gain	G _v	V _{in} = 5mV	50.5	52.5	54.5	dB	
Total Harmonic Distortion	THD	V _{in} = 5mV	—	0.20	0.75	%	
Max. Output Power (4Ω)	P _O	THD = 10%	9.0	12.5	—	W	
Ripple Rejection Ratio ^{Note)}	RR	R _g = 0Ω, V _{in} = 0mV, Ripple = 300mVrms, 120Hz	35	40	—	dB	
Output Offset Voltage	V _{O (offset)}	R _g = 0Ω	-200	0	+ 200	mV	
Channel Balance	CB	V _{in} = 5mV	-1	0	+ 1	dB	
Total Harmonic Distortion	THD	V _{in} = 5mV, 100Hz	—	0.26	—	%	
Total Harmonic Distortion	THD	V _{in} = 5mV, 10kHz	—	0.45	—	%	
Frequency Characteristics	f _{CH}	V _{in} = 5mV, -3dB down	—	22	—	kHz	
Frequency Characteristics	f _{CL}	V _{in} = 5mV, -3dB down	—	21	—	Hz	
Stand-by Current	I _{STB}	Stand-by Pin ON	AN7171NK	—	21	—	μA
			AN7176K	400	650	1000	μA
Crosstalk	CT	V _{in} = 5mV, R _g = 10kΩ	—	61	—	dB	

Note) With 15Hz to 30kHz (12dB/OCT) filter

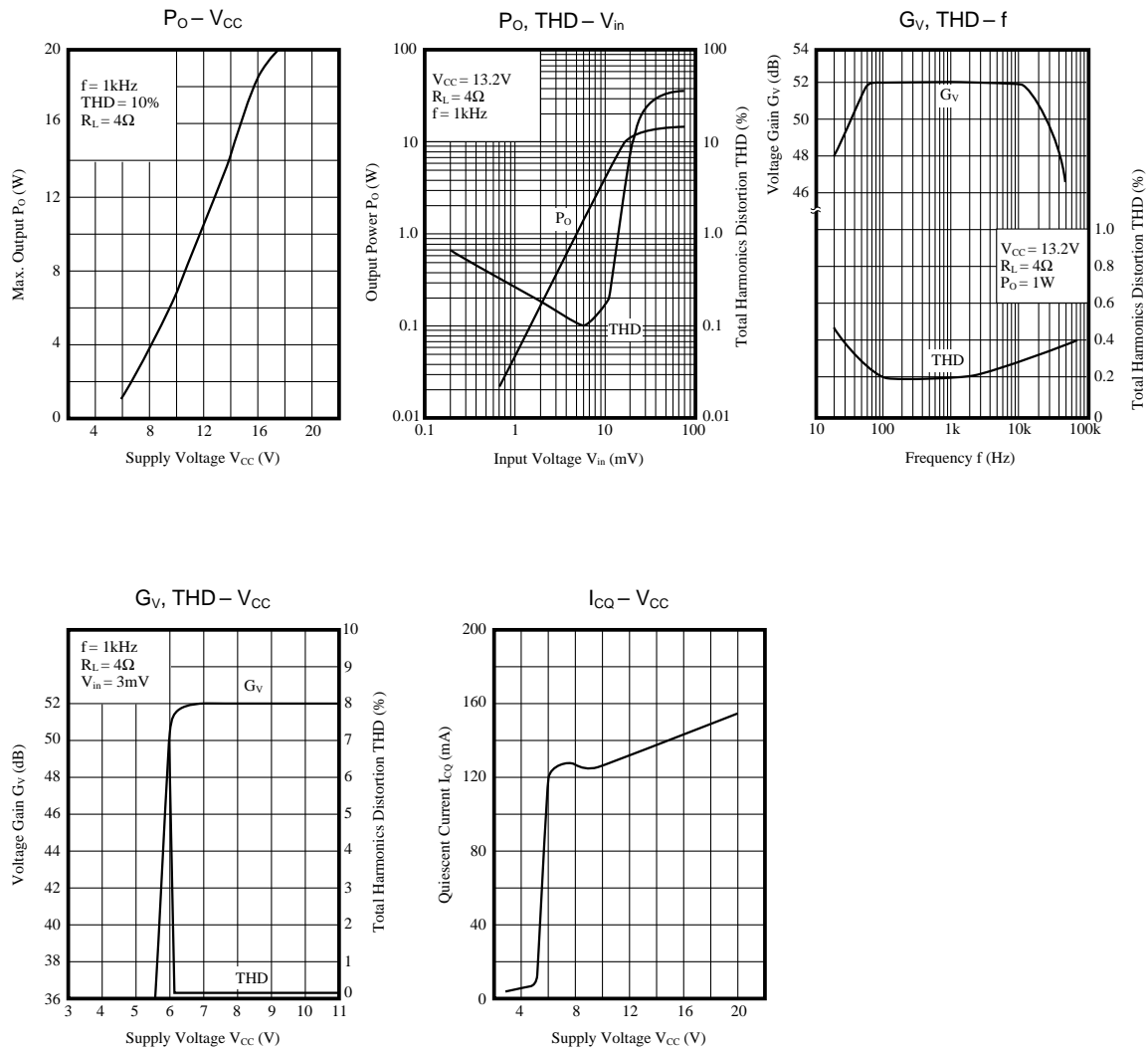

■ Precautions on use

1. Always attach an outside heat sink to use the chip. In addition, the outside heat sink must be fastened onto a chassis for use.
2. Connect the radiation fin to the GND potential.
3. Prevent atmospheric and ground faults, and load short-circuit.
4. The temperature protective circuit gets actuated when $T_j = \text{approx. } 150^\circ\text{C}$, but it is automatically reset when the chip temperature drops below the above set level.
5. The overvoltage protective circuit starts the protective operation at $V_{CC}26\text{V}$.
6. The ground fault protective circuit starts the protective operation at 0.3Ω or less of contact resistance.
7. The load short-circuit protective circuit starts the protective operation at 0.3Ω or less of contact resistance.
8. The atmospheric fault protective circuit protects the chip only from short-circuit between pins.
9. Take into consideration the heat radiation design particularly when V_{CC} is set high or when the load is 2Ω .

■ Application Circuit

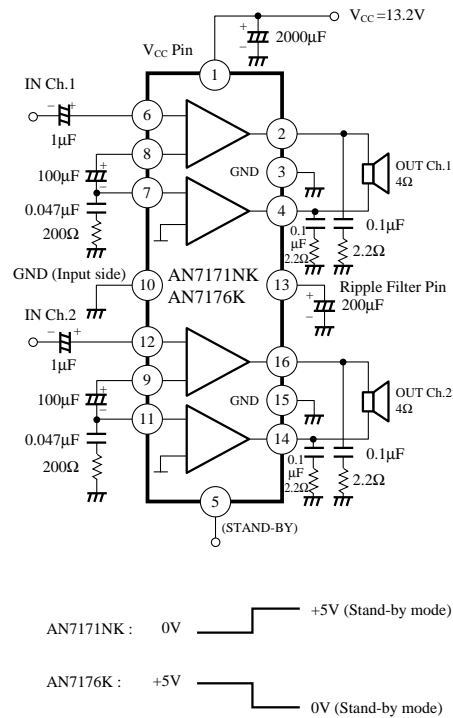

■ Printed Circuit Board Layout

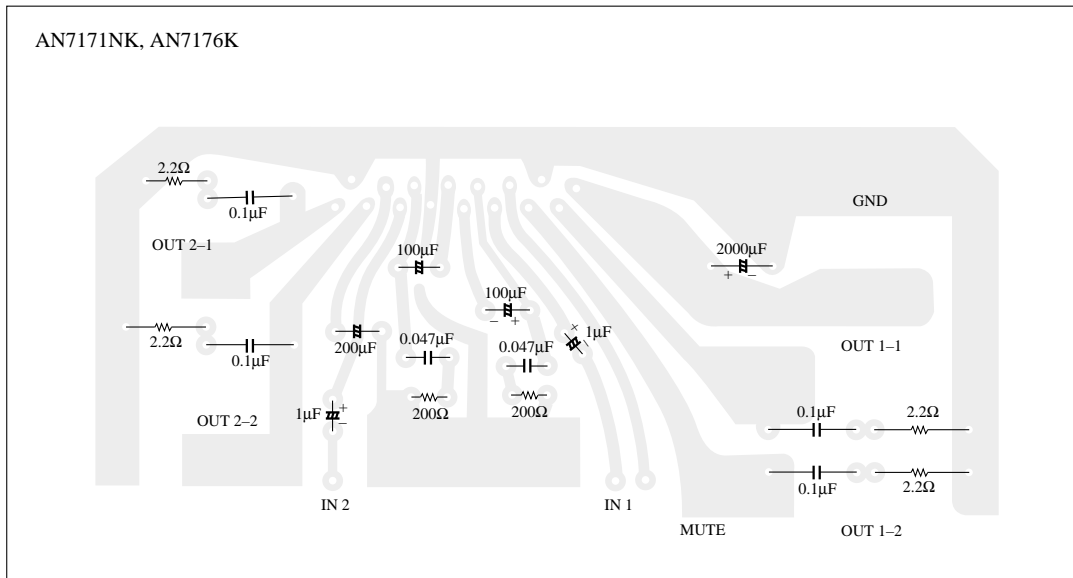



LittleDiode supplies new, hard to find or obsolete electronic components and semiconductors all over the world.

With over two million different components listed you are sure to find the part you need.

Feel free to visit us today at our online store:

LittleDiode.com

Looking forward to providing you with the best possible service.