

**ARF440 125W 50V 13.56MHz**  
**ARF441 125W 50V 13.56MHz**

THE ARF440 PIN-OUTS ARE MIRROR IMAGE OF THE ARF441.

## RF OPERATION (1-15MHz)

**POWER MOS IV®**

### N-CHANNEL ENHANCEMENT MODE RF POWER MOSFET

The ARF440 and ARF441 comprise a symmetric pair of RF power transistors designed for narrow-band push-pull commercial, medical and industrial RF power amplifier applications.

- Specified 50 Volt, 13.56 MHz Characteristics:
- Output Power = 125 Watts.
- Gain = 21dB (Typ.)
- Efficiency = 63% (Typ.)
- Low Cost Common Source RF Package.
- Very High Breakdown for Improved Ruggedness.
- Low Thermal Resistance.
- Nitride Passivated Die for Improved Reliability.

#### MAXIMUM RATINGS

All Ratings:  $T_C = 25^\circ\text{C}$  unless otherwise specified.

Symbol	Parameter	ARF440/441	UNIT
$V_{DSS}$	Drain-Source Voltage	150	Volts
$V_{DGO}$	Drain-Gate Voltage	150	
$I_D$	Continuous Drain Current @ $T_C = 25^\circ\text{C}$	11	Amps
$V_{GS}$	Gate-Source Voltage	$\pm 30$	Volts
$P_D$	Total Power Dissipation @ $T_C = 25^\circ\text{C}$	167	Watts
$R_{\theta JC}$	Junction to Case	0.75	$^\circ\text{C}/\text{W}$
$T_J, T_{STG}$	Operating and Storage Junction Temperature Range	-55 to 150	$^\circ\text{C}$
$T_L$	Lead Temperature: 0.063" from Case for 10 Sec.	300	

#### STATIC ELECTRICAL CHARACTERISTICS

Symbol	Characteristic / Test Conditions	MIN	TYP	MAX	UNIT
$BV_{DSS}$	Drain-Source Breakdown Voltage ( $V_{GS} = 0\text{V}, I_D = 250 \mu\text{A}$ )	150			Volts
$V_{DS(ON)}$	On State Drain Voltage <sup>①</sup> ( $I_D(ON) = 10\text{A}, V_{GS} = 10\text{V}$ )			6	
$I_{DSS}$	Zero Gate Voltage Drain Current ( $V_{DS} = V_{DSS}, V_{GS} = 0\text{V}$ )			250	$\mu\text{A}$
	Zero Gate Voltage Drain Current ( $V_{DS} = 0.8 V_{DSS}, V_{GS} = 0\text{V}, T_C = 125^\circ\text{C}$ )			1000	
$I_{GSS}$	Gate-Source Leakage Current ( $V_{GS} = \pm 30\text{V}, V_{DS} = 0\text{V}$ )			$\pm 100$	nA
$g_{fs}$	Forward Transconductance ( $V_{DS} = 10\text{V}, I_D = 5.5\text{A}$ )	4	5		mhos
$V_{GS(TH)}$	Gate Threshold Voltage ( $V_{DS} = V_{GS}, I_D = 200\text{mA}$ )	2		5	Volts

**CAUTION:** These Devices are Sensitive to Electrostatic Discharge. Proper Handling Procedures Should Be Followed.

APT Website - <http://www.advancedpower.com>

**USA**  
 405 S.W. Columbia Street  
**EUROPE**

Avenue J.F. Kennedy Bât B4 Parc Cadéra Nord

Bend, Oregon 97702-1035

F-33700 Merignac - France

Phone: (541) 382-8028

Phone: (33) 5 57 92 15 15

FAX: (541) 388-0364

FAX: (33) 5 56 47 97 61

Symbol	Characteristic	Test Conditions	MIN	TYP	MAX	UNIT
$C_{iss}$	Input Capacitance	$V_{GS} = 0V$ $V_{DS} = 50V$ $f = 1\text{ MHz}$		755	900	pF
$C_{oss}$	Output Capacitance			155	215	
$C_{rss}$	Reverse Transfer Capacitance			55	90	

FUNCTIONAL CHARACTERISTICS

Symbol	Characteristic	Test Conditions	MIN	TYP	MAX	UNIT
$G_{PS}$	Common Source Amplifier Power Gain	$V_{DD} = 50V$ $P_{out} = 125W$ $I_{DQ} = 200mA$ $f = 13.56MHz$	18	21		dB
$\eta$	Drain Efficiency			63		%
$\psi$	Electrical Ruggedness VSWR 30:1		No Degradation in Output Power			

① Pulse Test: Pulse width < 380  $\mu$ S, Duty Cycle < 2%

APT Reserves the right to change, without notice, the specifications and information contained herein.

**TYPICAL 13.56 MHz, 250 WATT PUSH-PULL POWER AMPLIFIER CIRCUIT**

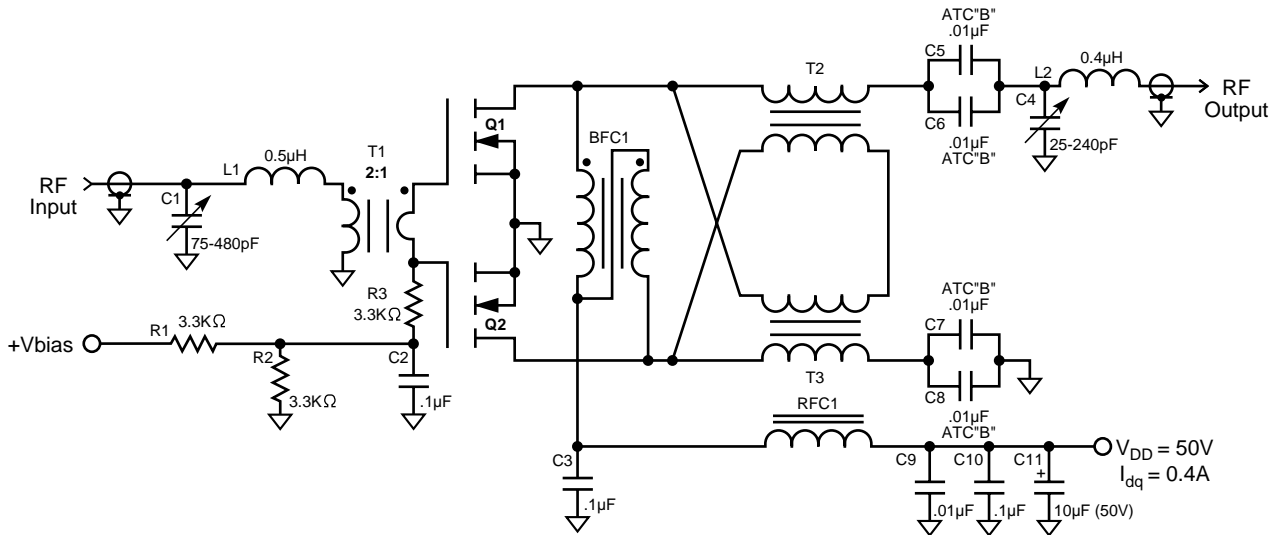

**Parts List**

- C1 = 75-480pF Compression Mica
- C2, C3 & C10 = .1 $\mu$ F @ 50V, Novacap #1210B104K500N
- C4 = 25-240pF Compression Mica
- C5, C6, C7, C8 & C9 = .01 $\mu$ F @ 50V, Novacap #1210B103K500N
- C11 = 10 $\mu$ F @ 50V Electrolytic
- R1, R2 & R3 = 1K $\Omega$ , 5%, 1/4W, Carbon
- Q1 = ARF440
- Q2 = ARF441

- L1 = 7.5 T of #18AWG, ID = .438", L = 0.5 $\mu$ H
- L2 = 6.5 T of #18AWG, ID = .438", L = 0.4 $\mu$ H

BFC1 = Balanced DC Feed Choke; 7 T of #18 stranded PTFE twisted pair on an Indiana General #F624-19-Q1 toroid.  $\mu$ i = 125  
 RFC1 = 2 T of #18 stranded PTFE on a Fair-Rite #2677006301 shield bead.  $\mu$ i = 2000

T1 = 4:1 Z Conventional Transformer; 2:1 T of #22 stranded PTFE on a Fair-Rite #2843000202 Balun Core.  $\mu$ i = 850  
 T2 & 3 = 1:4 Z Transmission Line Transformer; 6 T of mini 25 $\Omega$  PTFE coax on a Fair-Rite #2643102002 shield bead.  $\mu$ i = 2000

PCB = .062" G10 Epoxy Glass.

# ARF440/441

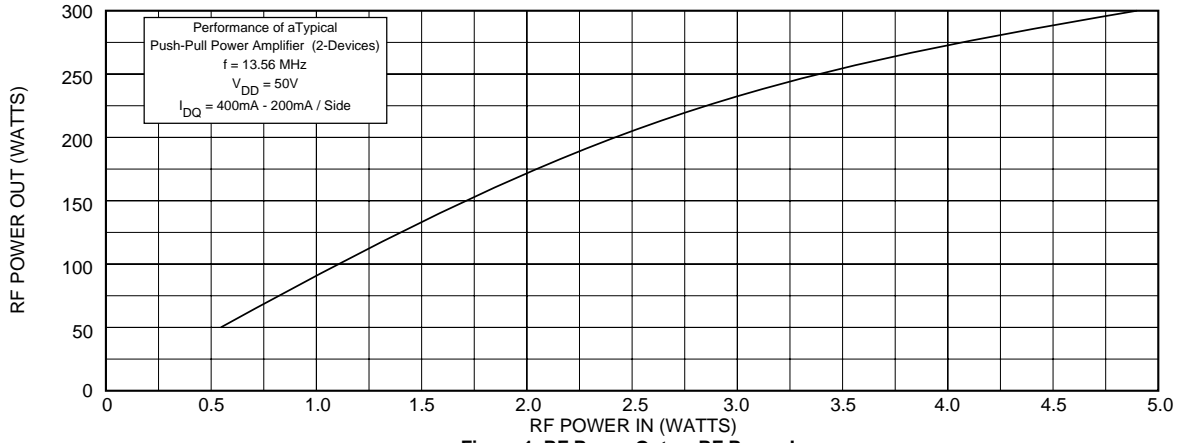

Figure 1, RF Power Out vs RF Power In

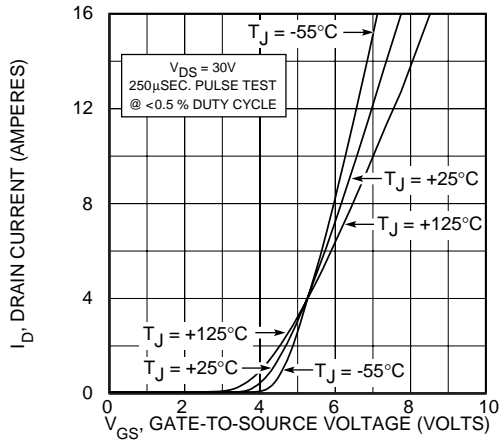

Figure 2, Typical Transfer Characteristics

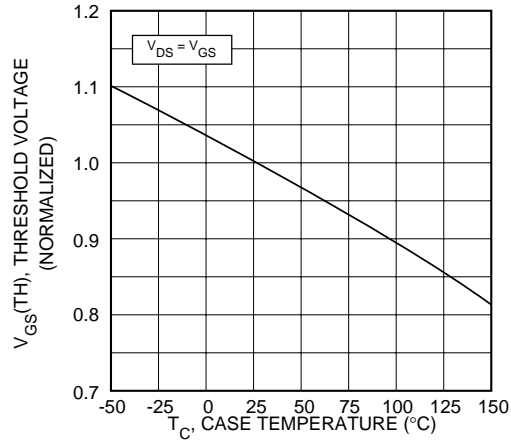

Figure 3, Threshold Voltage vs Temperature

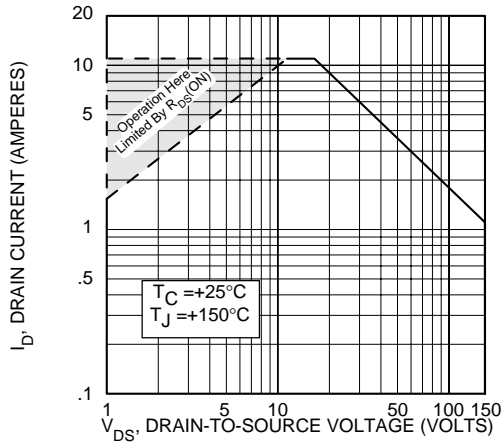

Figure 4, Maximum DC Safe Operating Area

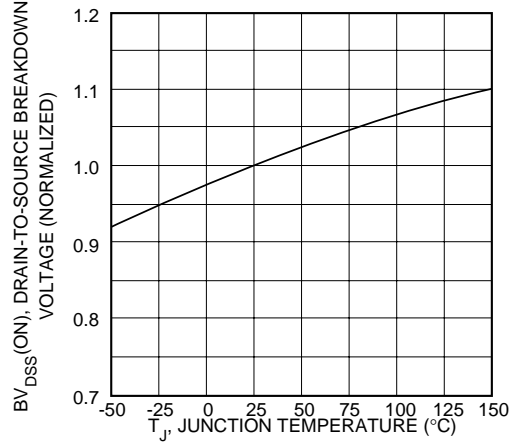

Figure 5, Breakdown Voltage vs Temperature

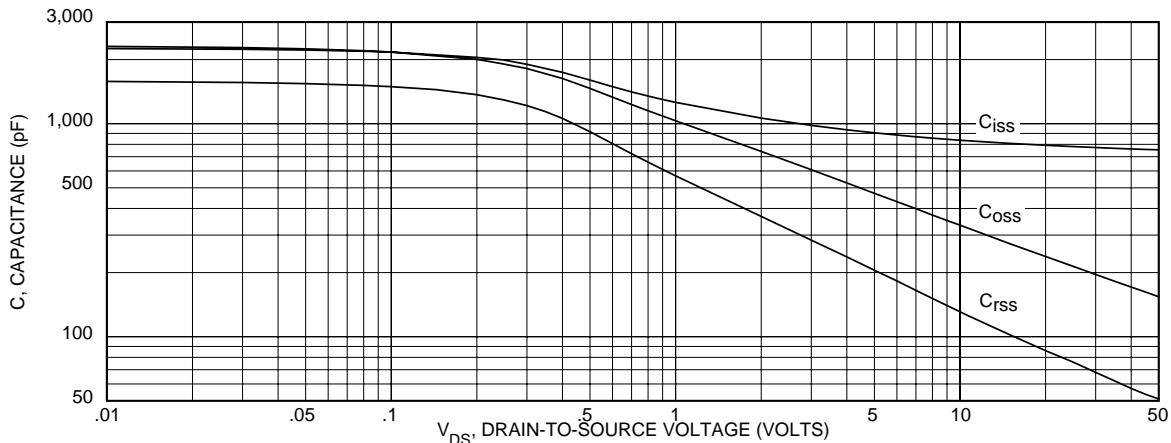
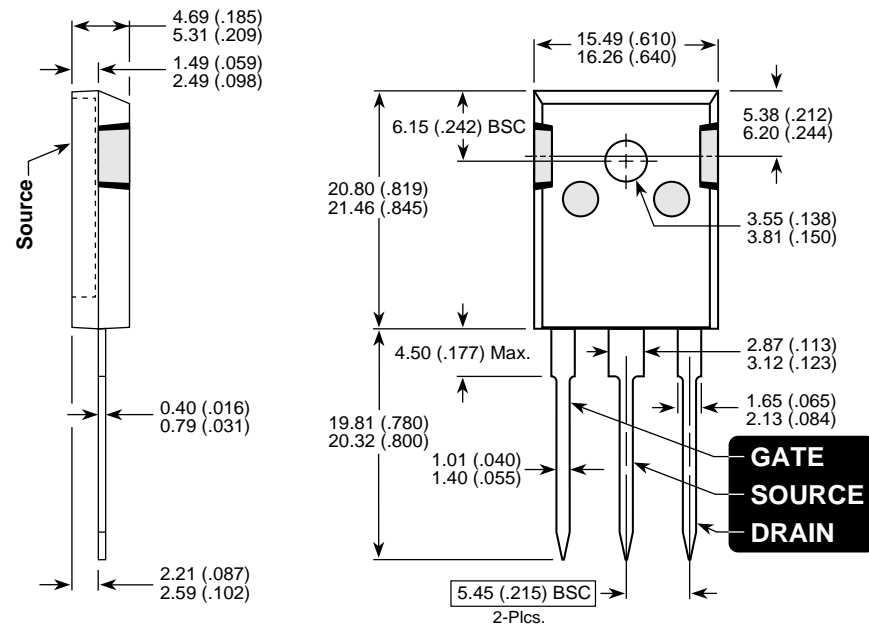

Figure 6, Typical Capacitance vs. Drain-To-Source Voltage

## TO-247AD Package Outline

## ARF440



Dimensions in Millimeters and (Inches)

## ARF441

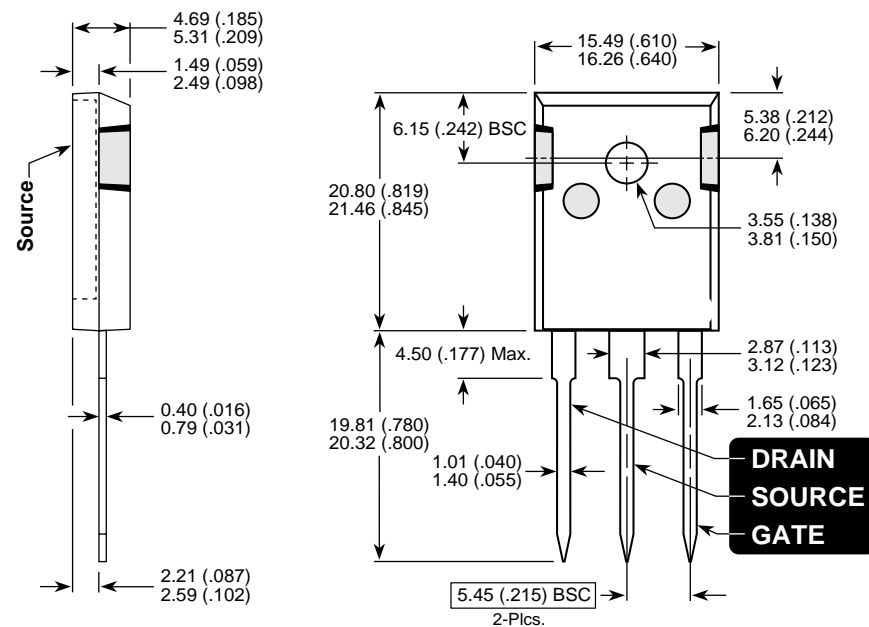

Dimensions in Millimeters and (Inches)

**NOTE: The ARF440 and ARF441 comprise a symmetric pair of RF power transistors and meet the same electrical specifications. The device pin-outs are the mirror image of each other to allow ease of use as a push-pull pair.**



**CAUTION:** These Devices are Sensitive to Electrostatic Discharge. Proper Handling Procedures Should Be Followed.

USA  
405 S.W. Columbia Street  
EUROPE

Avenue J.F. Kennedy Bât B4 Parc Cadéra Nord F-33700 Merignac - France Phone: (33) 5 57 92 15 15 FAX: (33) 5 56 47 97 61



LittleDiode supplies new, hard to find or obsolete electronic components and semiconductors all over the world.

With over two million different components listed you are sure to find the part you need.

Feel free to visit us today at our online store:

[LittleDiode.com](http://LittleDiode.com)

Looking forward to providing you with the best possible service.