

## Features

- Utilizes the AVR<sup>®</sup> Enhanced RISC Architecture
- AVR - High Performance and Low Power RISC Architecture
- 118 Powerful Instructions - Most Single Clock Cycle Execution
- 2K bytes of In-System Programmable ISP Flash
  - SPI Serial Interface for In-System Programming
  - Endurance: 1,000 Write/Erase Cycles
- 128 bytes EEPROM
  - Endurance: 100,000 Write/Erase Cycles
- 128 bytes Internal RAM
- 32 x 8 General Purpose Working Registers
  - 3 AT90S/LS2323 Programmable I/O Lines
  - 5 AT90S/LS2343 Programmable I/O Lines
- V<sub>CC</sub>: 4.0 - 6.0V AT90S2323/AT90S2343
- V<sub>CC</sub>: 2.7 - 6.0V AT90LS2323/AT90LS2343
- Power-On Reset Circuit
- Speed Grades: 0 - 10 MHz AT90S2323/AT90S2343
- Speed Grades: 0 - 4 MHz AT90LS2323/AT90LS2343
- Up to 10 MIPS Throughput at 10 MHz
- One 8-Bit Timer/Counter with Separate Prescaler
- External and Internal Interrupt Sources
- Programmable Watchdog Timer with On-Chip Oscillator
- Low Power Idle and Power Down Modes
- Programming Lock for Flash Program and EEPROM Data Security
- Selectable On-Chip RC Oscillator
- 8-Pin Device

## Description

The AT90S/LS2323 and AT90S/LS2343 is a low-power CMOS 8-bit microcontrollers based on the AVR<sup>®</sup> enhanced RISC architecture. By executing powerful instructions in a single clock cycle, the AT90S/LS2323 and AT90S/LS2343 achieves throughputs approaching 1 MIPS per MHz allowing the system designer to optimize power consumption versus processing speed.

The AVR core combines a rich instruction set with 32 general purpose working registers. All the 32 registers are directly connected to the Arithmetic Logic Unit (ALU), allowing two independent registers to be accessed in one single instruction executed in one clock cycle. The resulting architecture is more code efficient while achieving throughputs up to ten times faster than conventional CISC microcontrollers.

## Pin Configuration

PDIP/SOIC

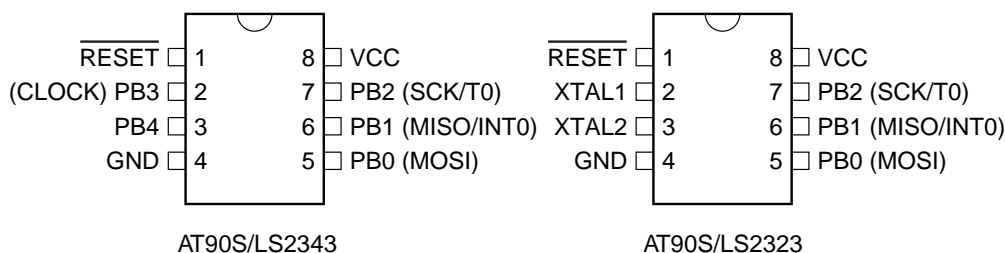

8-Bit AVR<sup>®</sup>  
Microcontroller  
with 2K Bytes of  
In-System  
Programmable  
Flash

AT90S2323  
AT90LS2323  
AT90S2343  
AT90LS2343  
Preliminary

Rev. 1004AS-05/98



Note: This is a summary document. For the complete 34 page document, please visit our website at [www.atmel.com](http://www.atmel.com) or e-mail at [literature@atmel.com](mailto:literature@atmel.com) and request literature #1004A.

# Block Diagram

Figure 1. The AT90S/LS2343 Block Diagram

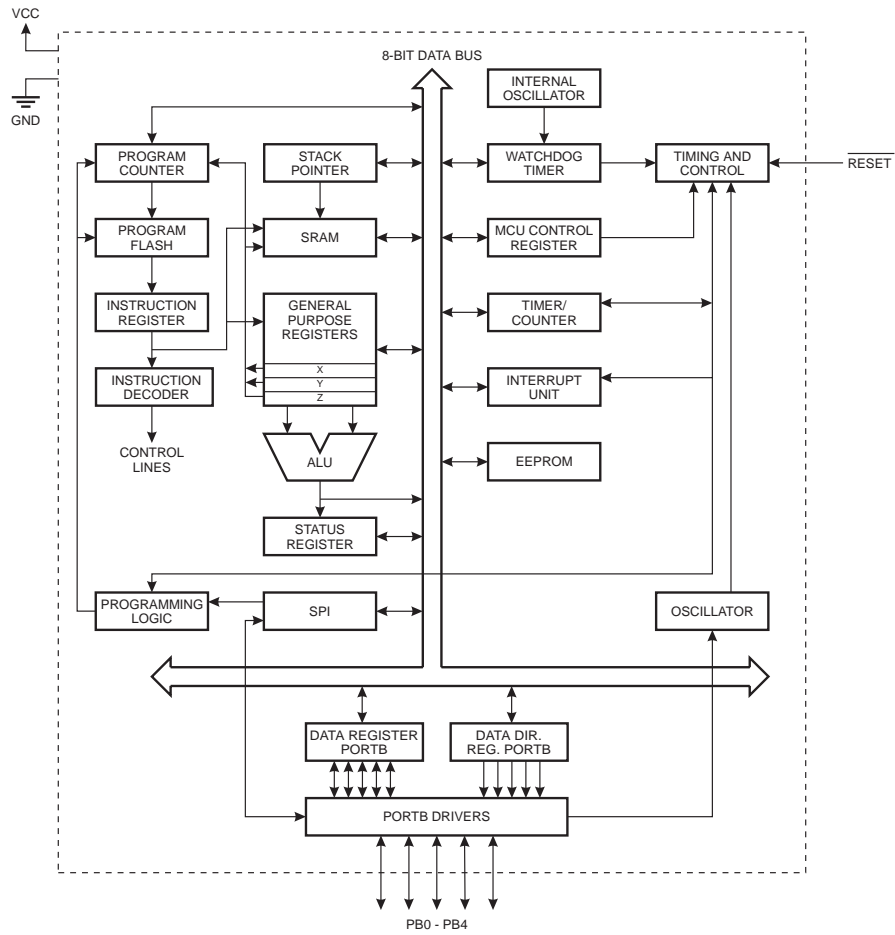

**Figure 2.** The AT90S/LS2323 Block Diagram

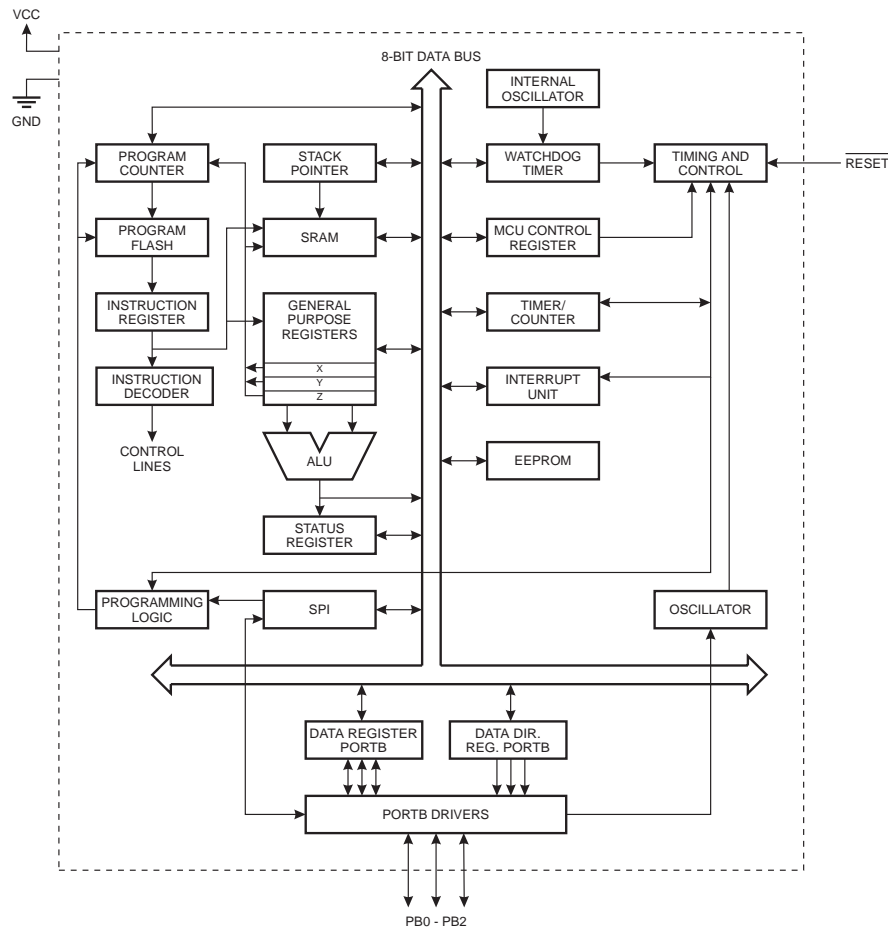

## Description

The AT90S/LS2323 and AT90S/LS2343 provides the following features: 2K bytes of In-System Programmable Flash, 128 bytes EEPROM, 128 bytes SRAM, 3 (AT90S/LS2323) / 5 (AT90S/LS2343) general purpose I/O lines, 32 general purpose working registers, an 8-bit timer/counter, internal and external interrupts, programmable Watchdog Timer with internal oscillator, an SPI serial port for Flash Memory downloading and two software selectable power saving modes. The Idle Mode stops the CPU while allowing the SRAM, timer/counters, SPI port and interrupt system to continue functioning. The power down mode saves the register contents but freezes the oscillator, disabling all other chip functions until the next interrupt or hardware reset.

The device is manufactured using Atmel's high density non-volatile memory technology. The on-chip Flash allows the program memory to be reprogrammed in-system through an SPI serial interface. By combining an 8-bit RISC CPU with ISP Flash on a monolithic chip, the Atmel AT90S/LS2323 and AT90S/LS2343 is a powerful micro-

controller that provides a highly flexible and cost effective solution to many embedded control applications.

The AT90S/LS2323 and AT90S/LS2343 AVR is supported with a full suite of program and system development tools including: C compilers, macro assemblers, program debugger/simulators, in-circuit emulators, and evaluation kits.

## Comparison Between AT90S/LS2323 and AT90S/LS2343

The AT90S/LS2323 is intended for use with external quartz crystal or ceramic resonator as the clock source. The start-up time is fuse selectable as either 1 ms (suitable for ceramic resonator) or 16 ms (suitable for crystal). The device has three I/O pins.

The AT90S/LS2343 is intended for use with either an external clock source or the internal RC oscillator as clock source. The device has five I/O pins.

Table 1 summarizes the differences in features of the two devices.

**Table 1.** Feature Difference Summary

Part	AT90S/LS2323	AT90S/LS2343
On-chip oscillator amplifier	yes	no
Internal RC Clock	no	yes
PB3 usable	never	internal clock mode
PB4 usable	never	always
Startup time	1 ms / 16 ms	16 $\mu$ s fixed

## Pin Descriptions AT90S/LS2323

### VCC

Supply voltage pin.

### GND

Ground pin.

### Port B (PB2..PB0)

Port B is a 3-bit bi-directional I/O port. Port pins can provide internal pull-up resistors (selected for each bit).

### RESET

Reset input. A low on this pin for two machine cycles while the oscillator is running resets the device.

### XTAL1

Input to the inverting oscillator amplifier and input to the internal clock operating circuit.

### XTAL2

Output from the inverting oscillator amplifier.

## Pin Descriptions AT90S/LS2343

### VCC

Supply voltage pin.

### GND

Ground pin.

### Port B (PB4..PB0)

Port B is a 5-bit bi-directional I/O port. Port pins can provide internal pull-up resistors (selected for each bit). When the device is clocked from an external clock source, PB3 is used as the clock input.

### RESET

Reset input. A low on this pin for two machine cycles while the oscillator is running resets the device.

### CLOCK

Clock signal input in external clock mode.

## Clock Sources

The AT90S/LS2323 contains an inverting amplifier which can be configured for use as an on-chip oscillator, as shown in Figure 3. XTAL1 and XTAL2 are input and output respectively. Either a quartz crystal or a ceramic resonator may be used. It is recommended to use the AT90S/LS2343 if an external clock source is used, since this gives an extra I/O pin.

The AT90S/LS2343 can be clocked by an external clock signal, as shown in Figure 4, or by the on-chip RC oscillator. This RC oscillator runs at a nominal frequency of 1 MHz ( $V_{CC} = 5V$ ). A fuse bit - RCEN - in the Flash memory selects the on-chip RC oscillator as the clock source when programmed ('0'). The AT90S/LS2343 is shipped with this bit programmed.

**Figure 3.** Oscillator Connection

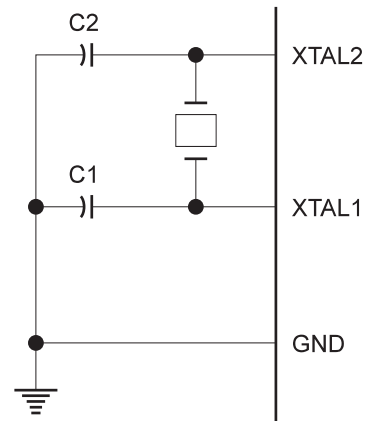

**Figure 4.** External Clock Drive Configuration

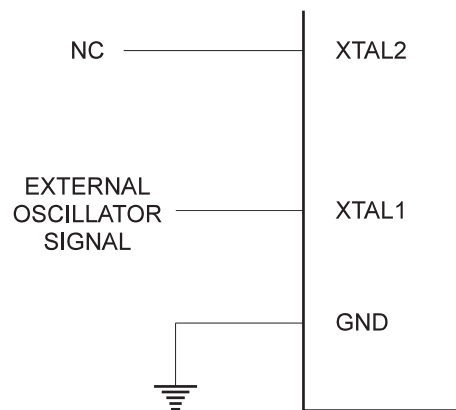

## AT90S/LS2323 and AT90S/LS2343 Architectural Overview

The fast-access register file concept contains 32 x 8-bit general purpose working registers with a single clock cycle access time. This means that during one single clock cycle, one ALU (Arithmetic Logic Unit) operation is executed. Two operands are output from the register file, the operation is executed, and the result is stored back in the register file - in one clock cycle.

Six of the 32 registers can be used as three 16-bit indirect address register pointers for Data Space addressing - enabling efficient address calculations. One of the three address pointers is also used as the address pointer for the constant table look up function. These added function registers are the 16-bit X-register, Y-register and Z-register.

The ALU supports arithmetic and logic functions between registers or between a constant and a register. Single register operations are also executed in the ALU. Figure 5 shows the AT90S/LS2323 and AT90S/LS2343 AVR Enhanced RISC microcontroller architecture.

In addition to the register operation, the conventional memory addressing modes can be used on the register file as well. This is enabled by the fact that the register file is assigned the 32 lowermost Data Space addresses (\$00 - \$1F), allowing them to be accessed as though they were ordinary memory locations.

The I/O memory space contains 64 addresses for CPU peripheral functions as Control Registers, Timer/Counters,

A/D-converters, and other I/O functions. The I/O memory can be accessed directly, or as the Data Space locations following those of the register file, \$20 - \$5F.

The AVR has Harvard architecture - with separate memories and buses for program and data. The program memory is accessed with a two stage pipeline. While one instruction is being executed, the next instruction is pre-fetched from the program memory. This concept enables instructions to be executed in every clock cycle. The program memory is in-system downloadable Flash memory.

With the relative jump and call instructions, the whole 1K address space is directly accessed. Most AVR instructions have a single 16-bit word format. Every program memory address contains a 16- or 32-bit instruction.

During interrupts and subroutine calls, the return address program counter (PC) is stored on the stack. The stack is effectively allocated in the general data SRAM, and consequently the stack size is only limited by the total SRAM size and the usage of the SRAM. All user programs must initialize the SP in the reset routine (before subroutines or interrupts are executed). The 8-bit stack pointer SP is read/write accessible in the I/O space.

The 128 bytes data SRAM + register file and I/O registers can be easily accessed through the five different addressing modes supported in the AVR architecture.

The memory spaces in the AVR architecture are all linear and regular memory maps.

**Figure 5.** The AT90S/LS2323 and AT90S/LS2343 AVR Enhanced RISC Architecture

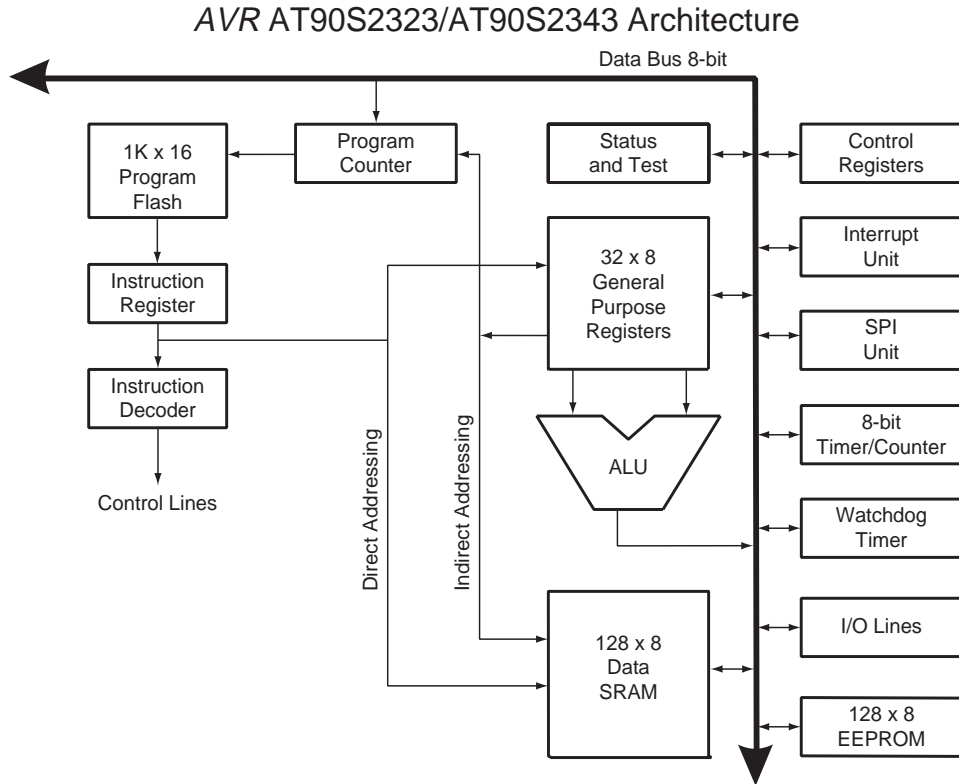

**Figure 6.** Memory Maps

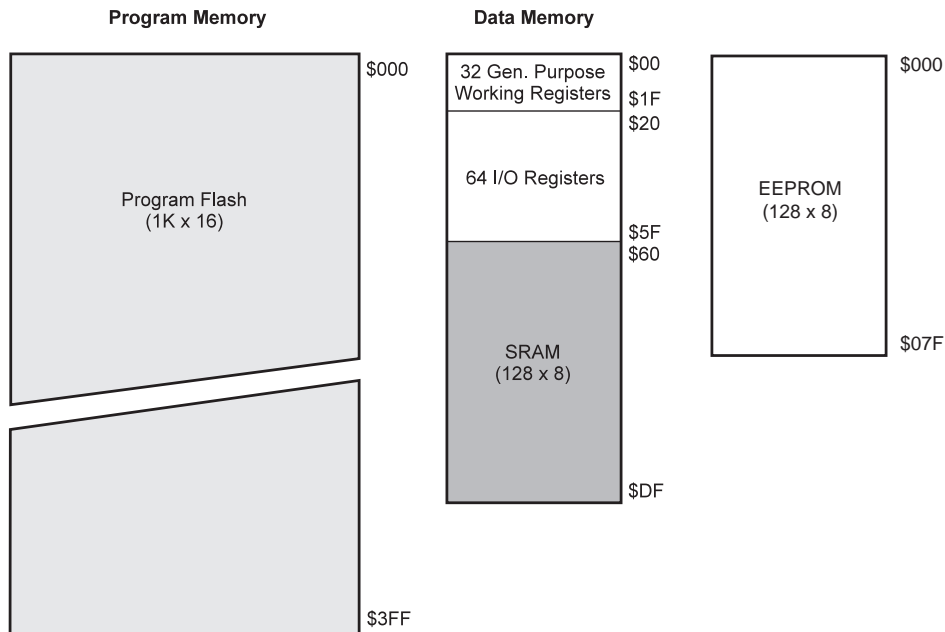



## AT90S/LS2323 and AT90S/LS2343 Register Summary

Address	Name	Bit 7	Bit 6	Bit 5	Bit 4	Bit 3	Bit 2	Bit 1	Bit 0	Page
\$3F (\$5F)	SREG	I	T	H	S	V	N	Z	C	page 13
\$3E (\$5E)	Reserved									
\$3D (\$5D)	SPL	SP7	SP6	SP5	SP4	SP3	SP2	SP1	SP0	page 13
\$3C (\$5C)	Reserved									
\$3B (\$5B)	GIMSK	-	INT0	-	-	-	-	-	-	page 17
\$3A (\$5A)	GIFR	-	INTF0							page 17
\$39 (\$59)	TIMSK	-	-	-	-	-	-	TOIE0	-	page 15
\$38 (\$58)	TIFR	-	-	-	-	-	-	TOV0	-	page 16
\$37 (\$57)	Reserved									
\$36 (\$56)	Reserved									
\$35 (\$55)	MCUCR	-	-	SE	SM	-	-	ISC01	ISC00	page 16
\$34 (\$54)	MCUSR	-	-	-	-	-	-	EXTRF	PORF	page 14
\$33 (\$53)	TCCR0	-	-	-	-	-	CS02	CS01	CS00	page 20
\$32 (\$52)	TCNT0	Timer/Counter0 (8 Bit)								page 20
\$31 (\$51)	Reserved									
\$30 (\$50)	Reserved									
\$2F (\$4F)	Reserved									
\$2E (\$4E)	Reserved									
\$2D (\$4D)	Reserved									
\$2C (\$4C)	Reserved									
\$2B (\$4B)	Reserved									
\$2A (\$4A)	Reserved									
\$29 (\$49)	Reserved									
\$28 (\$48)	Reserved									
\$27 (\$47)	Reserved									
\$26 (\$46)	Reserved									
\$25 (\$45)	Reserved									
\$24 (\$44)	Reserved									
\$23 (\$43)	Reserved									
\$22 (\$42)	Reserved									
\$21 (\$41)	WDTCR	-	-	-	WDTO	WDE	WDP2	WDP1	WDP0	page 21
\$20 (\$40)	Reserved									
\$1F (\$3F)	Reserved									
\$1E (\$3E)	EEAR	-	EEPROM Address Register							page 22
\$1D (\$3D)	EEDR	EEPROM Data register								page 22
\$1C (\$3C)	EEDR	-	-	-	-	-	EEMW	EERE	EERE	page 22
\$1B (\$3B)	Reserved									
\$1A (\$3A)	Reserved									
\$19 (\$39)	Reserved									
\$18 (\$38)	PORTB	-	-	-	PORTB	PORTB	PORTB	PORTB	PORTB	page 23
\$17 (\$37)	DDRB	-	-	-	DDB4	DDB3	DDB2	DDB1	DDB0	page 23
\$16 (\$36)	PINB	-	-	-	PINB4	PINB3	PINB2	PINB1	PINB0	page 23
\$15 (\$35)	Reserved									
\$14 (\$34)	Reserved									
\$13 (\$33)	Reserved									
\$12 (\$32)	Reserved									
\$11 (\$31)	Reserved									
\$10 (\$30)	Reserved									
\$0F (\$2F)	Reserved									
\$0E (\$2E)	Reserved									
\$0D (\$2D)	Reserved									
\$0C (\$2C)	Reserved									
\$0B (\$2B)	Reserved									
\$0A (\$2A)	Reserved									
\$09 (\$29)	Reserved									
\$08 (\$28)	Reserved									
...	Reserved									
\$00 (\$20)	Reserved									

## AT90S/LS2323 and AT90S/LS2343 Instruction Set Summary

Mnemonics	Operands	Description	Operation	Flags	#Clock
<b>ARITHMETIC AND LOGIC INSTRUCTIONS</b>					
ADD	Rd, Rr	Add two Registers	$Rd \leftarrow Rd + Rr$	Z,C,N,V,H	1
ADC	Rd, Rr	Add with Carry two Registers	$Rd \leftarrow Rd + Rr + C$	Z,C,N,V,H	1
ADIW	Rdl,K	Add Immediate to Word	$Rdh:Rdl \leftarrow Rdh:Rdl + K$	Z,C,N,V,S	2
SUB	Rd, Rr	Subtract two Registers	$Rd \leftarrow Rd - Rr$	Z,C,N,V,H	1
SUBI	Rd, K	Subtract Constant from Register	$Rd \leftarrow Rd - K$	Z,C,N,V,H	1
SBIW	Rdl,K	Subtract Immediate from Word	$Rdh:Rdl \leftarrow Rdh:Rdl - K$	Z,C,N,V,S	2
SBC	Rd, Rr	Subtract with Carry two Registers	$Rd \leftarrow Rd - Rr - C$	Z,C,N,V,H	1
SBCI	Rd, K	Subtract with Carry Constant from Reg.	$Rd \leftarrow Rd - K - C$	Z,C,N,V,H	1
AND	Rd, Rr	Logical AND Registers	$Rd \leftarrow Rd \cdot Rr$	Z,N,V	1
ANDI	Rd, K	Logical AND Register and Constant	$Rd \leftarrow Rd \cdot K$	Z,N,V	1
OR	Rd, Rr	Logical OR Registers	$Rd \leftarrow Rd \vee Rr$	Z,N,V	1
ORI	Rd, K	Logical OR Register and Constant	$Rd \leftarrow Rd \vee K$	Z,N,V	1
EOR	Rd, Rr	Exclusive OR Registers	$Rd \leftarrow Rd \oplus Rr$	Z,N,V	1
COM	Rd	One's Complement	$Rd \leftarrow \$FF - Rd$	Z,C,N,V	1
NEG	Rd	Two's Complement	$Rd \leftarrow \$00 - Rd$	Z,C,N,V,H	1
SBR	Rd,K	Set Bit(s) in Register	$Rd \leftarrow Rd \vee K$	Z,N,V	1
CBR	Rd,K	Clear Bit(s) in Register	$Rd \leftarrow Rd \cdot (\$FF - K)$	Z,N,V	1
INC	Rd	Increment	$Rd \leftarrow Rd + 1$	Z,N,V	1
DEC	Rd	Decrement	$Rd \leftarrow Rd - 1$	Z,N,V	1
TST	Rd	Test for Zero or Minus	$Rd \leftarrow Rd \cdot Rd$	Z,N,V	1
CLR	Rd	Clear Register	$Rd \leftarrow Rd \oplus Rd$	Z,N,V	1
SER	Rd	Set Register	$Rd \leftarrow \$FF$	None	1
<b>BRANCH INSTRUCTIONS</b>					
RJMP	k	Relative Jump	$PC \leftarrow PC + k + 1$	None	2
IJMP		Indirect Jump to (Z)	$PC \leftarrow Z$	None	2
RCALL	k	Relative Subroutine Call	$PC \leftarrow PC + k + 1$	None	3
ICALL		Indirect Call to (Z)	$PC \leftarrow Z$	None	3
RET		Subroutine Return	$PC \leftarrow STACK$	None	4
RETI		Interrupt Return	$PC \leftarrow STACK$	I	4
CPSE	Rd,Rr	Compare, Skip if Equal	if $(Rd = Rr)$ $PC \leftarrow PC + 2$ or $3$	None	1 / 2
CP	Rd,Rr	Compare	$Rd - Rr$	Z, N,V,C,H	1
CPC	Rd,Rr	Compare with Carry	$Rd - Rr - C$	Z, N,V,C,H	1
CPI	Rd,K	Compare Register with Immediate	$Rd - K$	Z, N,V,C,H	1
SBRC	Rr, b	Skip if Bit in Register Cleared	if $(Rr(b)=0)$ $PC \leftarrow PC + 2$ or $3$	None	1 / 2
SBRS	Rr, b	Skip if Bit in Register is Set	if $(Rr(b)=1)$ $PC \leftarrow PC + 2$ or $3$	None	1 / 2
SBIC	P, b	Skip if Bit in I/O Register Cleared	if $(P(b)=0)$ $PC \leftarrow PC + 2$ or $3$	None	1 / 2
SBIS	P, b	Skip if Bit in I/O Register is Set	if $(P(b)=1)$ $PC \leftarrow PC + 2$ or $3$	None	1 / 2
BRBS	s, k	Branch if Status Flag Set	if $(SREG(s) = 1)$ then $PC \leftarrow PC + k + 1$	None	1 / 2
BRBC	s, k	Branch if Status Flag Cleared	if $(SREG(s) = 0)$ then $PC \leftarrow PC + k + 1$	None	1 / 2
BREQ	k	Branch if Equal	if $(Z = 1)$ then $PC \leftarrow PC + k + 1$	None	1 / 2
BRNE	k	Branch if Not Equal	if $(Z = 0)$ then $PC \leftarrow PC + k + 1$	None	1 / 2
BRCS	k	Branch if Carry Set	if $(C = 1)$ then $PC \leftarrow PC + k + 1$	None	1 / 2
BRCC	k	Branch if Carry Cleared	if $(C = 0)$ then $PC \leftarrow PC + k + 1$	None	1 / 2
BRSH	k	Branch if Same or Higher	if $(C = 0)$ then $PC \leftarrow PC + k + 1$	None	1 / 2
BRLO	k	Branch if Lower	if $(C = 1)$ then $PC \leftarrow PC + k + 1$	None	1 / 2
BRMI	k	Branch if Minus	if $(N = 1)$ then $PC \leftarrow PC + k + 1$	None	1 / 2
BRPL	k	Branch if Plus	if $(N = 0)$ then $PC \leftarrow PC + k + 1$	None	1 / 2
BRGE	k	Branch if Greater or Equal, Signed	if $(N \oplus V = 0)$ then $PC \leftarrow PC + k + 1$	None	1 / 2
BRLT	k	Branch if Less Than Zero, Signed	if $(N \oplus V = 1)$ then $PC \leftarrow PC + k + 1$	None	1 / 2
BRHS	k	Branch if Half Carry Flag Set	if $(H = 1)$ then $PC \leftarrow PC + k + 1$	None	1 / 2
BRHC	k	Branch if Half Carry Flag Cleared	if $(H = 0)$ then $PC \leftarrow PC + k + 1$	None	1 / 2
BRTS	k	Branch if T Flag Set	if $(T = 1)$ then $PC \leftarrow PC + k + 1$	None	1 / 2
BRTC	k	Branch if T Flag Cleared	if $(T = 0)$ then $PC \leftarrow PC + k + 1$	None	1 / 2
BRVS	k	Branch if Overflow Flag is Set	if $(V = 1)$ then $PC \leftarrow PC + k + 1$	None	1 / 2
BRVC	k	Branch if Overflow Flag is Cleared	if $(V = 0)$ then $PC \leftarrow PC + k + 1$	None	1 / 2
BRIE	k	Branch if Interrupt Enabled	if $(I = 1)$ then $PC \leftarrow PC + k + 1$	None	1 / 2
BRID	k	Branch if Interrupt Disabled	if $(I = 0)$ then $PC \leftarrow PC + k + 1$	None	1 / 2

(continued)



Mnemonics	Operands	Description	Operation	Flags	#Clocks
<b>DATA TRANSFER INSTRUCTIONS</b>					
MOV	Rd, Rr	Move Between Registers	$Rd \leftarrow Rr$	None	1
LDI	Rd, K	Load Immediate	$Rd \leftarrow K$	None	1
LD	Rd, X	Load Indirect	$Rd \leftarrow (X)$	None	2
LD	Rd, X+	Load Indirect and Post-Inc.	$Rd \leftarrow (X), X \leftarrow X + 1$	None	2
LD	Rd, -X	Load Indirect and Pre-Dec.	$X \leftarrow X - 1, Rd \leftarrow (X)$	None	2
LD	Rd, Y	Load Indirect	$Rd \leftarrow (Y)$	None	2
LD	Rd, Y+	Load Indirect and Post-Inc.	$Rd \leftarrow (Y), Y \leftarrow Y + 1$	None	2
LD	Rd, -Y	Load Indirect and Pre-Dec.	$Y \leftarrow Y - 1, Rd \leftarrow (Y)$	None	2
LDD	Rd, Y+q	Load Indirect with Displacement	$Rd \leftarrow (Y + q)$	None	2
LD	Rd, Z	Load Indirect	$Rd \leftarrow (Z)$	None	2
LD	Rd, Z+	Load Indirect and Post-Inc.	$Rd \leftarrow (Z), Z \leftarrow Z + 1$	None	2
LD	Rd, -Z	Load Indirect and Pre-Dec.	$Z \leftarrow Z - 1, Rd \leftarrow (Z)$	None	2
LDD	Rd, Z+q	Load Indirect with Displacement	$Rd \leftarrow (Z + q)$	None	2
LDS	Rd, k	Load Direct from SRAM	$Rd \leftarrow (k)$	None	2
ST	X, Rr	Store Indirect	$(X) \leftarrow Rr$	None	2
ST	X+, Rr	Store Indirect and Post-Inc.	$(X) \leftarrow Rr, X \leftarrow X + 1$	None	2
ST	-X, Rr	Store Indirect and Pre-Dec.	$X \leftarrow X - 1, (X) \leftarrow Rr$	None	2
ST	Y, Rr	Store Indirect	$(Y) \leftarrow Rr$	None	2
ST	Y+, Rr	Store Indirect and Post-Inc.	$(Y) \leftarrow Rr, Y \leftarrow Y + 1$	None	2
ST	-Y, Rr	Store Indirect and Pre-Dec.	$Y \leftarrow Y - 1, (Y) \leftarrow Rr$	None	2
STD	Y+q, Rr	Store Indirect with Displacement	$(Y + q) \leftarrow Rr$	None	2
ST	Z, Rr	Store Indirect	$(Z) \leftarrow Rr$	None	2
ST	Z+, Rr	Store Indirect and Post-Inc.	$(Z) \leftarrow Rr, Z \leftarrow Z + 1$	None	2
ST	-Z, Rr	Store Indirect and Pre-Dec.	$Z \leftarrow Z - 1, (Z) \leftarrow Rr$	None	2
STD	Z+q, Rr	Store Indirect with Displacement	$(Z + q) \leftarrow Rr$	None	2
STS	k, Rr	Store Direct to SRAM	$(k) \leftarrow Rr$	None	2
LPM		Load Program Memory	$R0 \leftarrow (Z)$	None	3
IN	Rd, P	In Port	$Rd \leftarrow P$	None	1
OUT	P, Rr	Out Port	$P \leftarrow Rr$	None	1
PUSH	Rr	Push Register on Stack	$STACK \leftarrow Rr$	None	2
POP	Rd	Pop Register from Stack	$Rd \leftarrow STACK$	None	2
<b>BIT AND BIT-TEST INSTRUCTIONS</b>					
SBI	Pb	Set Bit in I/O Register	$I/O(Pb) \leftarrow 1$	None	2
CBI	Pb	Clear Bit in I/O Register	$I/O(Pb) \leftarrow 0$	None	2
LSL	Rd	Logical Shift Left	$Rd(n+1) \leftarrow Rd(n), Rd(0) \leftarrow 0$	Z,C,N,V	1
LSR	Rd	Logical Shift Right	$Rd(n) \leftarrow Rd(n+1), Rd(7) \leftarrow 0$	Z,C,N,V	1
ROL	Rd	Rotate Left Through Carry	$Rd(0) \leftarrow C, Rd(n+1) \leftarrow Rd(n), C \leftarrow Rd(7)$	Z,C,N,V	1
ROR	Rd	Rotate Right Through Carry	$Rd(7) \leftarrow C, Rd(n) \leftarrow Rd(n+1), C \leftarrow Rd(0)$	Z,C,N,V	1
ASR	Rd	Arithmetic Shift Right	$Rd(n) \leftarrow Rd(n+1), n=0..6$	Z,C,N,V	1
SWAP	Rd	Swap Nibbles	$Rd(3..0) \leftarrow Rd(7..4), Rd(7..4) \leftarrow Rd(3..0)$	None	1
BSET	s	Flag Set	$SREG(s) \leftarrow 1$	SREG(s)	1
BCLR	s	Flag Clear	$SREG(s) \leftarrow 0$	SREG(s)	1
BST	Rr, b	Bit Store from Register to T	$T \leftarrow Rr(b)$	T	1
BLD	Rd, b	Bit load from T to Register	$Rd(b) \leftarrow T$	None	1
SEC		Set Carry	$C \leftarrow 1$	C	1
CLC		Clear Carry	$C \leftarrow 0$	C	1
SEN		Set Negative Flag	$N \leftarrow 1$	N	1
CLN		Clear Negative Flag	$N \leftarrow 0$	N	1
SEZ		Set Zero Flag	$Z \leftarrow 1$	Z	1
CLZ		Clear Zero Flag	$Z \leftarrow 0$	Z	1
SEI		Global Interrupt Enable	$I \leftarrow 1$	I	1
CLI		Global Interrupt Disable	$I \leftarrow 0$	I	1
SES		Set Signed Test Flag	$S \leftarrow 1$	S	1
CLS		Clear Signed Test Flag	$S \leftarrow 0$	S	1
SEV		Set Twos Complement Overflow	$V \leftarrow 1$	V	1
CLV		Clear Twos Complement Overflow	$V \leftarrow 0$	V	1
SET		Set T in SREG	$T \leftarrow 1$	T	1
CLT		Clear T in SREG	$T \leftarrow 0$	T	1
SEH		Set Half Carry Flag in SREG	$H \leftarrow 1$	H	1
CLH		Clear Half Carry Flag in SREG	$H \leftarrow 0$	H	1
NOP		No Operation		None	1
SLEEP		Sleep	(see specific descr. for Sleep)	None	3
WDR		Watchdog Reset	(see specific descr. for WDR/timer)	None	1

## Ordering Information

Power Supply	Speed (MHz)	Ordering Code	Package	Operation Range
2.7 - 6.0V	4	AT90LS2343-4PC	8P3	Commercial (0°C to 70°C)
		AT90LS2343-4SC	8S2	
4.0 - 6.0V	10	AT90LS2343-4PI	8P3	Industrial (-40°C to 85°C)
		AT90LS2343-4SI	8S2	
2.7 - 6.0V	4	AT90S2343-10PC	8P3	Commercial (0°C to 70°C)
		AT90S2343-10SC	8S2	
4.0 - 6.0V	10	AT90S2343-10PI	8P3	Industrial (-40°C to 85°C)
		AT90S2343-10SI	8S2	
2.7 - 6.0V	4	AT90LS2323-4PC	8P3	Commercial (0°C to 70°C)
		AT90LS2323-4SC	8S2	
4.0 - 6.0V	10	AT90LS2323-4PI	8P3	Industrial (-40°C to 85°C)
		AT90LS2323-4SI	8S2	
2.7 - 6.0V	4	AT90S2323-10PC	8P3	Commercial (0°C to 70°C)
		AT90S2323-10SC	8S2	
4.0 - 6.0V	10	AT90S2323-10PI	8P3	Industrial (-40°C to 85°C)
		AT90S2323-10SI	8S2	

Package Type	
<b>8P3</b>	8-Lead, 0.300" Wide, Plastic Dual Inline Package (PDIP)
<b>8S2</b>	8-Lead, 0.200" Wide, Plastic Gull Wing Small Outline (SOIC)



## Packaging Information

**8P3**, 8-Lead, 0.300" Wide,  
Plastic Dual Inline Package (PDIP)  
Dimensions in Inches and (Millimeters)  
JEDEC STANDARD MS-001 BA

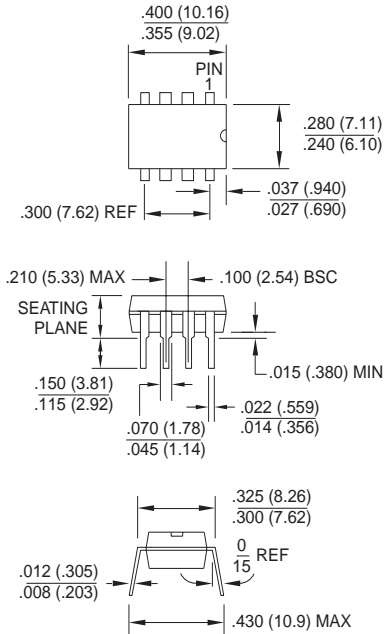

**8S2**, 8-Lead, 0.200" Wide,  
Plastic Gull Wing Small Outline (EIAJ SOIC)  
Dimensions in Inches and (Millimeters)

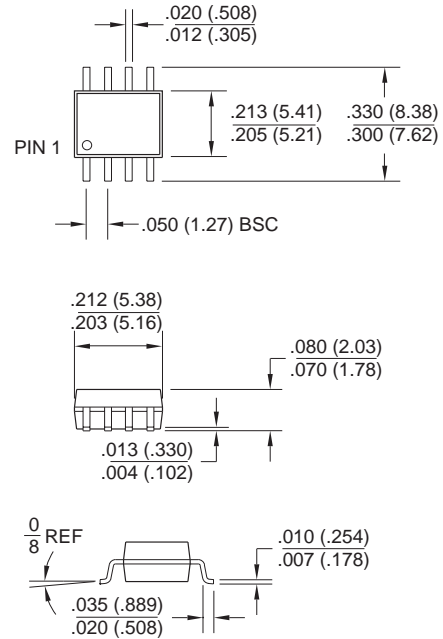

This datasheet has been downloaded from:

[www.DatasheetCatalog.com](http://www.DatasheetCatalog.com)

Datasheets for electronic components.



LittleDiode supplies new, hard to find or obsolete electronic components and semiconductors all over the world.

With over two million different components listed you are sure to find the part you need.

Feel free to visit us today at our online store:

[LittleDiode.com](http://LittleDiode.com)

Looking forward to providing you with the best possible service.