

Silicon Schottky Diode

BAT 15-098

Preliminary Data

- DBS mixer application to 10 GHz
- Low noise figure
- Low barrier type

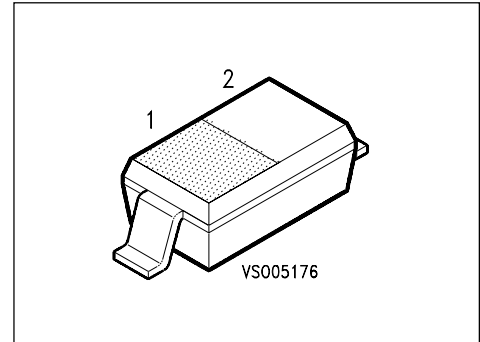

ESD: Electrostatic discharge sensitive device, observe handling precautions!

Type	Marking	Ordering Code (tape and reel)	Pin Configuration	Package ¹⁾
BAT 15-098	white B	Q62702-A0062		SOD-123

Maximum Ratings

Parameter	Symbol	Values	Unit
Reverse voltage	V_R	4	V
Forward current	I_F	110	mA
Power dissipation, $T_s \leq 80^\circ\text{C}$	P_{tot}	100	mW
Storage temperature range	T_{stg}	- 55 ... + 150	°C
Operating temperature range	T_{op}	- 55 ... + 150	

Thermal Resistance

Junction - ambient ²⁾	$R_{th JA}$	≤ 770	K/W
Junction - soldering point	$R_{th JS}$	≤ 690	

¹⁾ For detailed information see chapter Package Outlines.

²⁾ Package mounted on alumina 15 mm × 16.7 mm × 0.7 mm.

Electrical Characteristics per Diode
at $T_A = 25\text{ °C}$, unless otherwise specified.

Parameter	Symbol	Values			Unit
		min.	typ.	max.	
Breakdown voltage $I_R = 5\ \mu\text{A}$	$V_{(BR)}$	4	–	–	V
Forward voltage $I_F = 1\ \text{mA}$ $I_F = 10\ \text{mA}$	V_F	– –	0.23 0.32	– –	
Forward voltage matching $I_F = 10\ \text{mA}$	ΔV_F	–	–	20	mV
Diode capacitance $V_R = 0, f = 1\ \text{MHz}$	C_T	–	–	0.35	pF
Forward resistance $I_F = 10\ \text{mA}/50\ \text{mA}$	R_F	–	5.5	–	Ω

Forward current $I_F = f(V_F)$

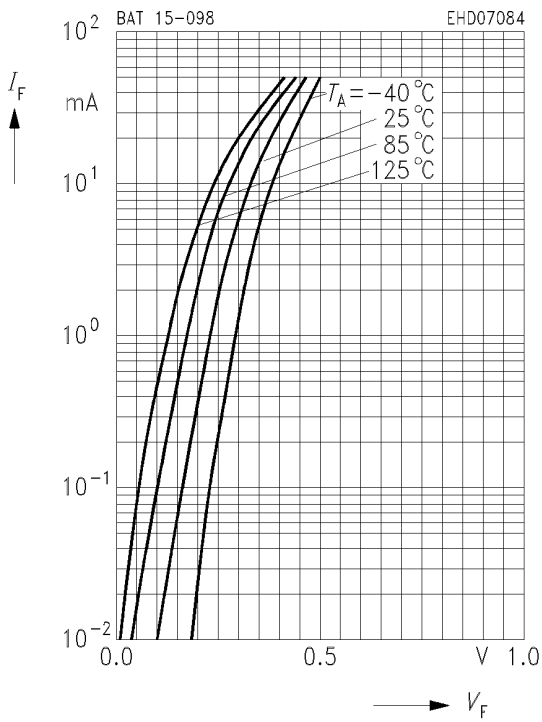

Forward current $I_F = f(T_S; T_A^*)$
*Package mounted on alumina

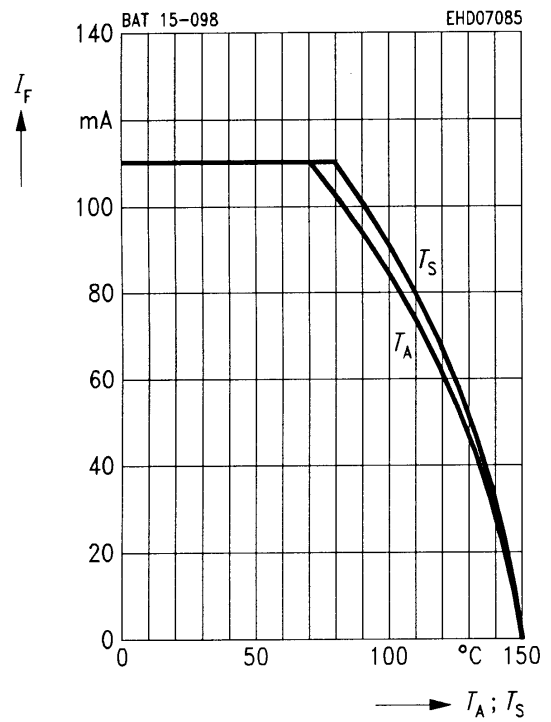

Reverse current $I_R = f(V_R)$

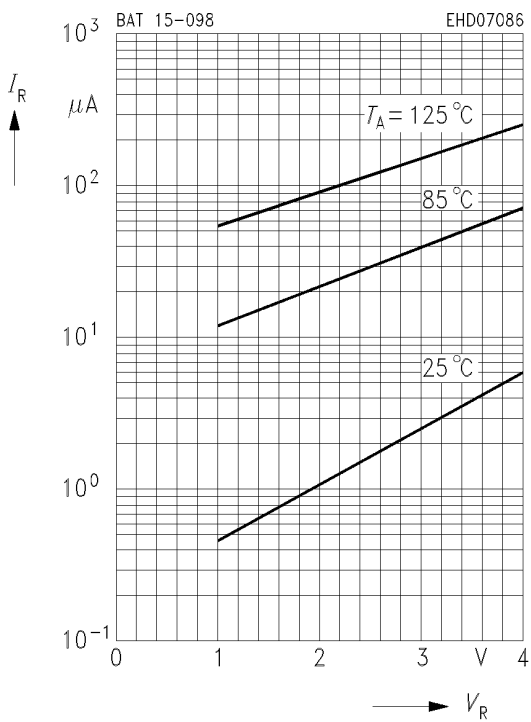

Diode capacitance $C_T = f(V_R)$
 $f = 1 \text{ MHz}$

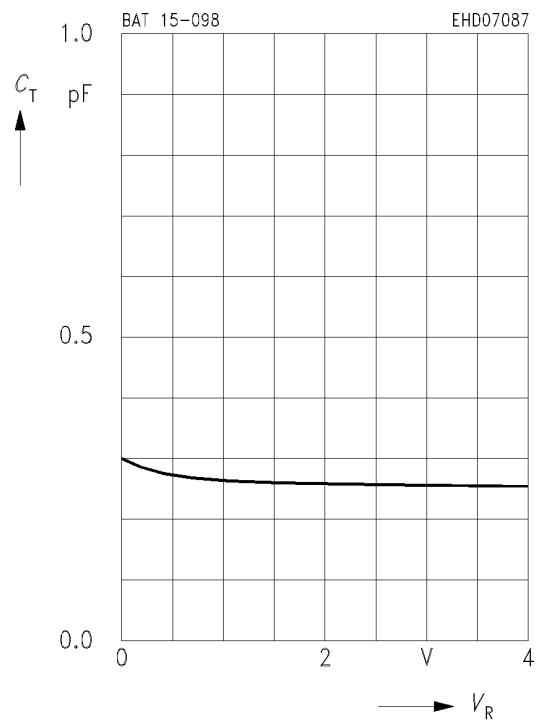

S₁₁-Parameters

Typical impedance characteristics (with external bias *I* and *Z*₀ = Ω)

<i>f</i>	<i>I</i> = 0.02 mA		<i>I</i> = 0.05 mA		<i>I</i> = 0.1 mA		<i>I</i> = 0.2 mA		<i>I</i> = 0.5 mA	
	MAG	ANG	MAG	ANG	MAG	ANG	MAG	ANG	MAG	ANG
1	0.96	- 22.19	0.83	- 24.20	0.71	- 24.59	0.71	- 24.59	0.06	- 36.11
2	0.95	- 44.30	0.82	- 46.30	0.68	- 46.70	0.68	- 46.70	0.04	- 53.72
3	0.94	- 68.60	0.80	- 71.30	0.65	- 72.30	0.65	- 72.30	0.03	- 94.30
4	0.91	- 96.40	0.76	- 100.00	0.61	- 101.50	0.61	- 101.50	0.09	122.49
5	0.88	- 127.50	0.74	- 133.50	0.57	- 138.50	0.57	- 138.50	0.18	101.50
6	0.87	- 165.30	0.72	- 174.30	0.55	- 151.30	0.55	- 151.30	0.29	81.30
7	0.86	- 150.50	0.72	141.50	0.60	133.70	0.60	133.70	0.41	65.70
8	0.89	109.60	0.78	101.70	0.68	94.70	0.68	94.70	0.52	49.50
9	0.91	75.20	0.84	68.89	0.77	63.90	0.77	63.90	0.61	33.50
10	0.93	45.10	0.88	41.10	0.83	38.40	0.83	38.40	0.71	19.49

$S_{11} = f(f, I)$

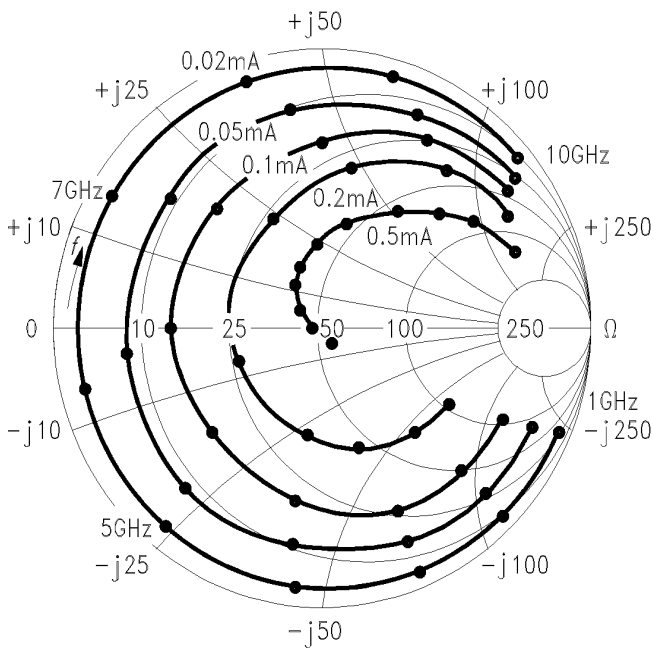

EHD07088



LittleDiode supplies new, hard to find or obsolete electronic components and semiconductors all over the world.

With over two million different components listed you are sure to find the part you need.

Feel free to visit us today at our online store:

LittleDiode.com

Looking forward to providing you with the best possible service.