

Active Bias Controller

Characteristics

- Supplies stable bias current even at low battery voltage and extreme ambient temperature variation
- Low voltage drop of 0.7V

Application notes

- Stabilizing bias current of NPN transistors and FET's from less than 0.2mA up to more than 200m.
- Ideal supplement for Sieget and other transistors
- also usable as current source up to 5mA

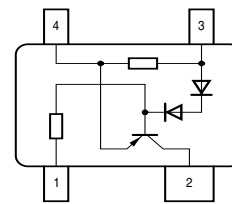
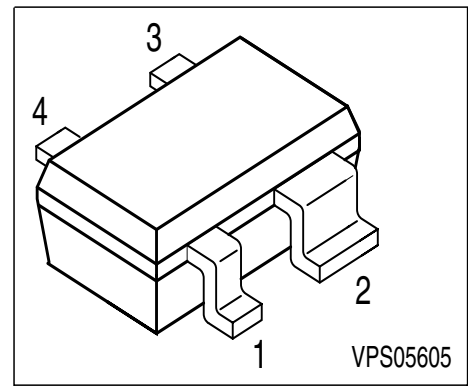

EHA07188

Type	Marking	Pin Configuration				Package
BCR 400W	W4s	1=GND/ E_{NPN}	2=Contr/ B_{NPN}	3V _S	4=Rext/ C_{NPN}	SOT-343

(E_{NPN}, B_{NPN}, C_{NPN} are electrodes of a stabilized NPN transistor)

Maximum Ratings

Parameter	Symbol	Value	Unit
Source voltage	V _S	18	V
Control current	I _{Contr.}	10	mA
Control voltage	V _{Contr.}	16	V
Reverse voltage between all terminals	V _R	0.5	V
Total power dissipation, T _S = 117 °C	P _{tot}	330	mW
Junction temperature	T _j	150	°C
Storage temperature	T _{stg}	-65 ... 150	

Thermal Resistance

Junction ambient ¹⁾	R _{thJA}	≤ 170	K/W
Thermal resistance, chip case	R _{thJC}	≤ 100	

1) Package mounted on pcb 40mm x 40mm x 1.5mm / 6cm² Cu

Electrical Characteristics at $T_A=25^\circ\text{C}$, unless otherwise specified

Parameter	Symbol	Values			Unit
		min.	typ.	max.	
DC Characteristics					
Additional current consumption $V_S = 3\text{ V}$	I_0	-	20	40	μA
Lowest stabilizing current $V_S = 3\text{ V}$	I_{min}	-	0.1	-	mA

DC Characteristics with stabilized NPN-Transistors

Lowest sufficient battery voltage $I_B (\text{NPN}) < 0.5\text{mA}$	$V_{S\text{min}}$	-	1.6	-	V
Voltage drop ($V_S - V_{CE}$) $I_C = 25\text{ mA}$	V_{drop}	-	0.65	-	
Change of I_C versus h_{FE} $h_{FE} = 50$	$\Delta I_C / I_C$	-	0.08	-	$\Delta h_{FE} / h_{FE}$
Change of I_C versus V_S $V_S = 3\text{ V}$	$\Delta I_C / I_C$	-	0.15	-	$\Delta V_S / V_S$
Change of I_C versus T_A	$\Delta I_C / I_C$	-	0.2	-	$\%/K$

Collector current $I_C = f(h_{FE})$

I_C and h_{FE} refer to stabilized NPN Transistor
Parameter $R_{ext.}$ (Ω)

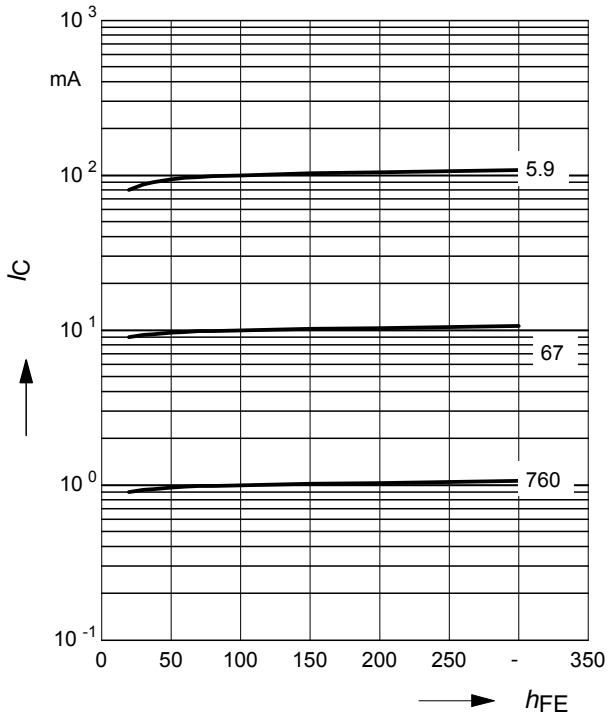

Collector Current $I_C = f(V_S)$

of stabilized NPN Transistor
Parameter $R_{ext.}$ (Ω)

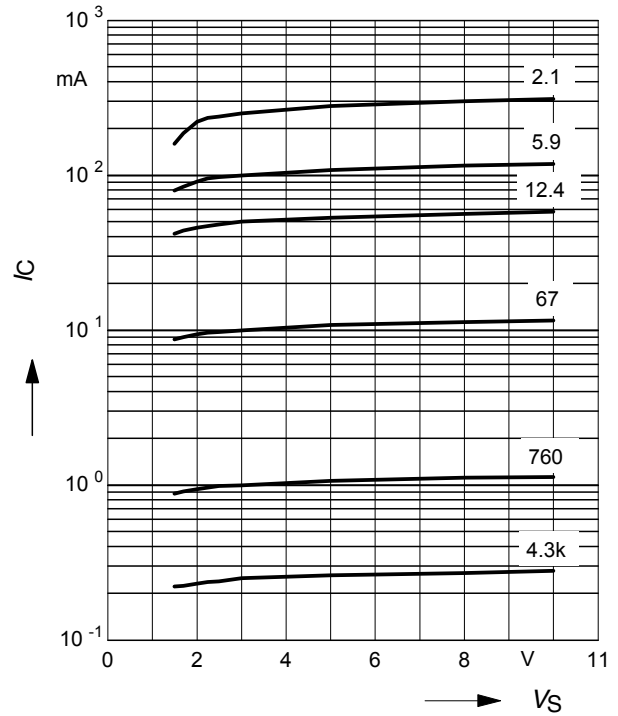

Voltage drop $V_{drop} = f(I_C)$

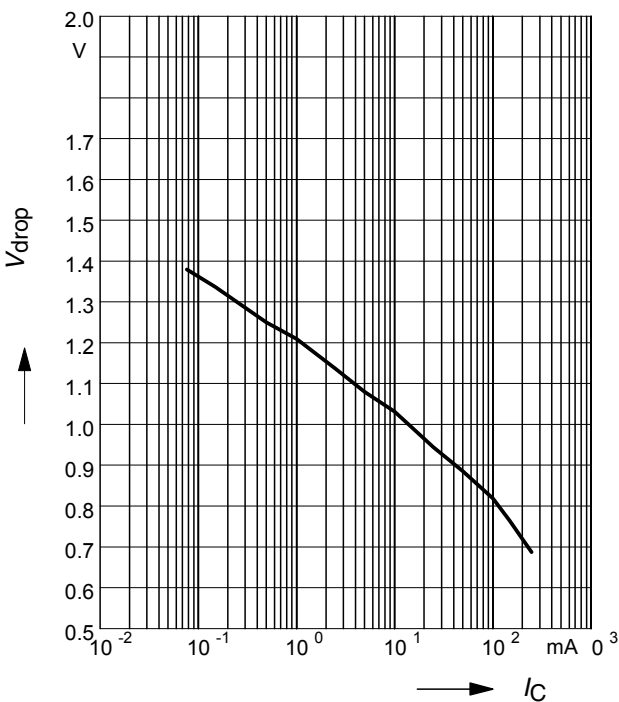

Collector current $I_C = f(R_{ext.})$

of stabilized NPN Transistor

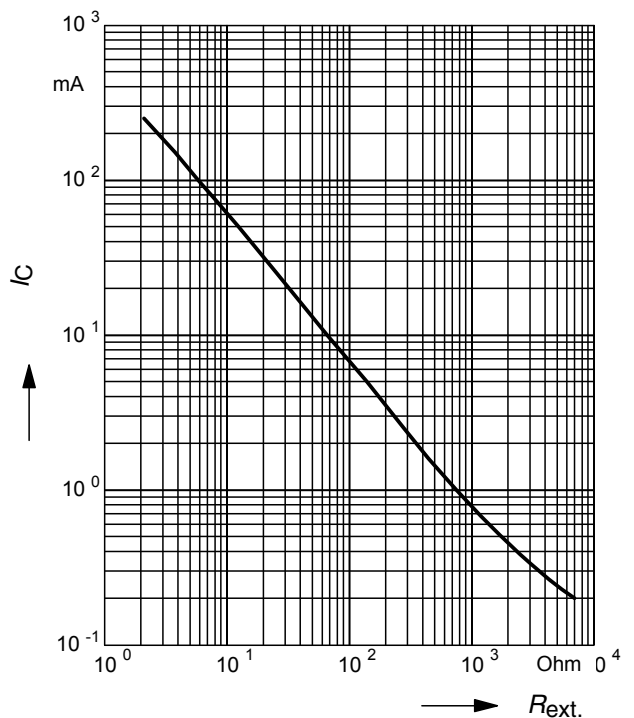

Collector current $T_A = f(I_C)$
of stabilized NPN Transistor

Parameter: $R_{ext.}(\Omega)$

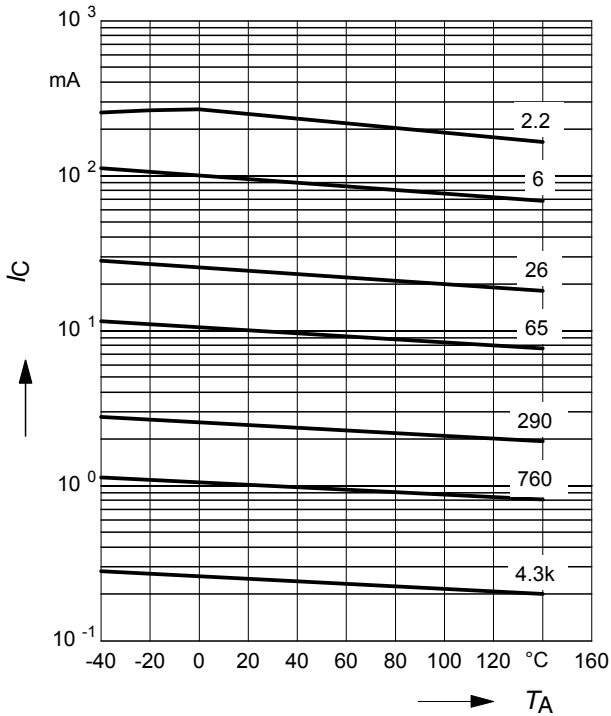

Control current $I = f(R_{ext.})$
in current source application

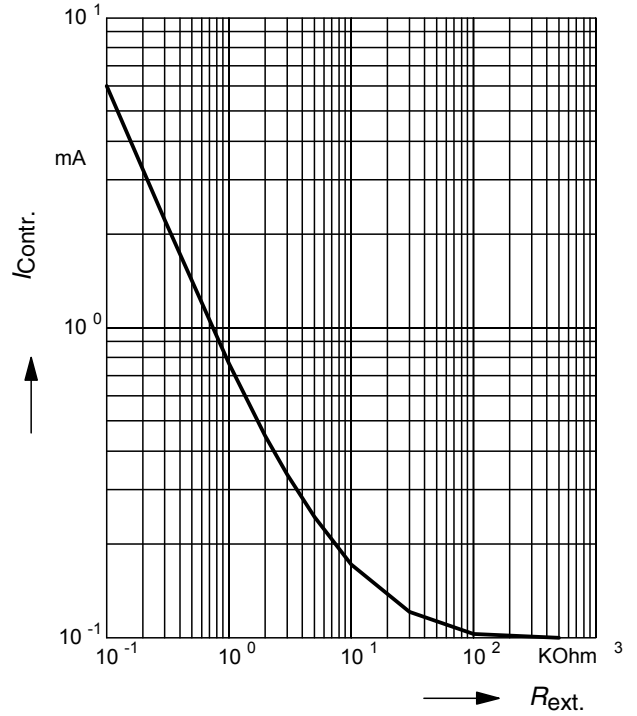

Control current $I = f(T_A)$
in current source application

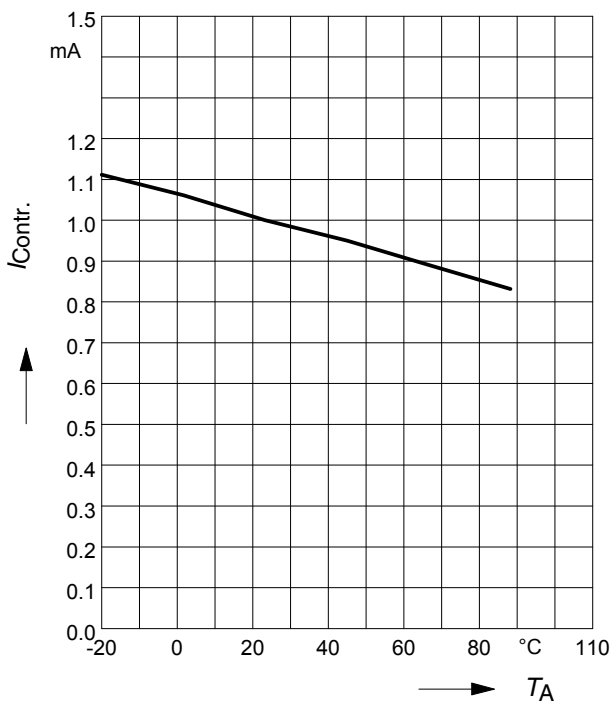

Control current $I = f(V_S)$
in current source application

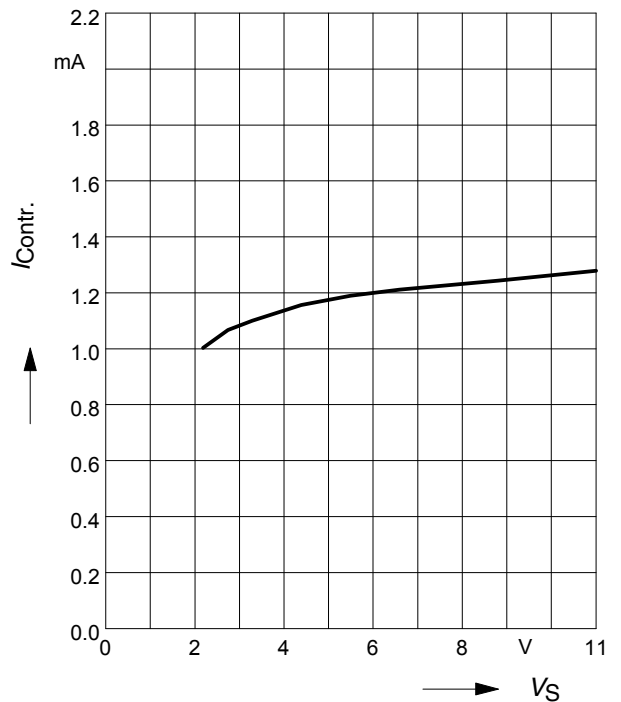

Total power dissipation $P_{tot} = f(T_A^*; T_S)$

* Package mounted on epoxy

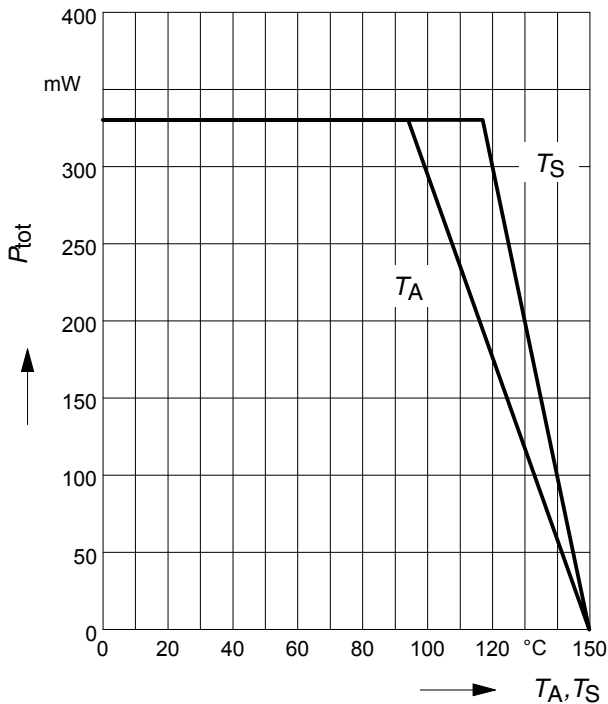

Note that up to $T_S=115^{\circ}\text{C}$ it is not possible to exceed P_{tot} respecting the maximum ratings of V_S and I_{Contr} . The collector or drain current (respectively) of the stabilized RF transistor does not affect BCR 400 directly, as it provides just the base current.

Typical application for GaAs FET with active bias controller

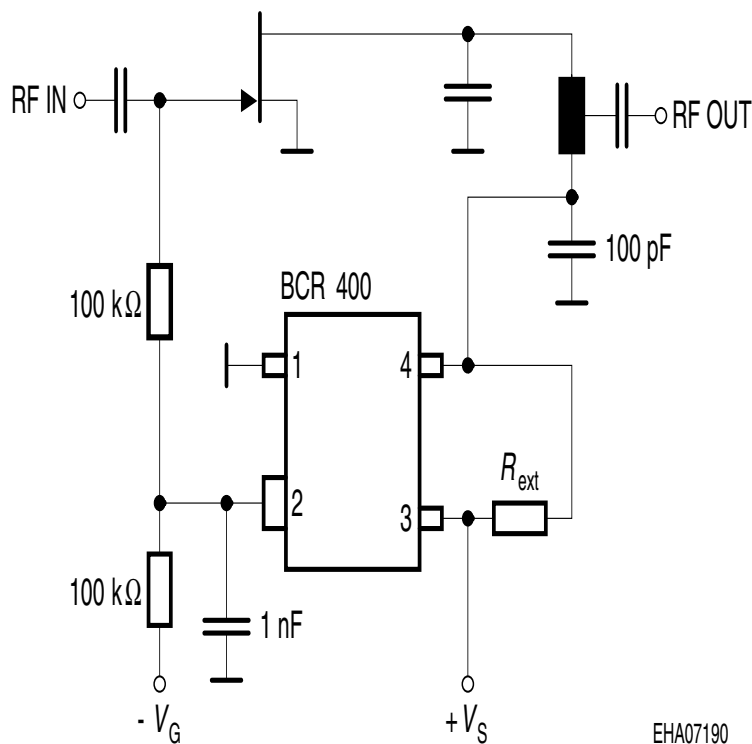

EHA07190

RF transistor controlled by BCR 400

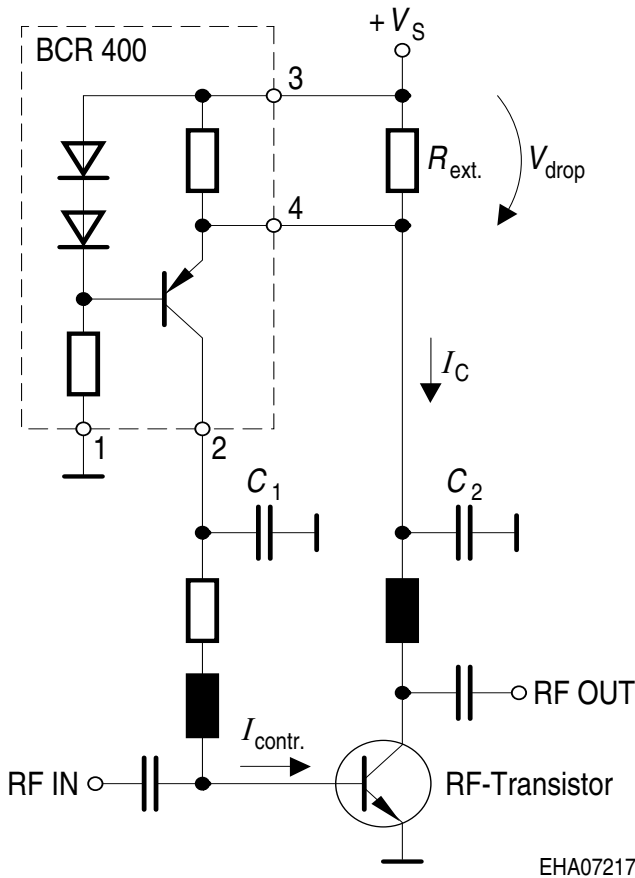

Be aware that BCR 400 stabilized bias current of transistors in an active control loop

In order to avoid loop ascillation (hunting), time constants must be chosen adequately, i.e. $C1 \geq 10 \times C2$

RX/TX antenna switch, compatible to control logic and working at wide battery voltage range

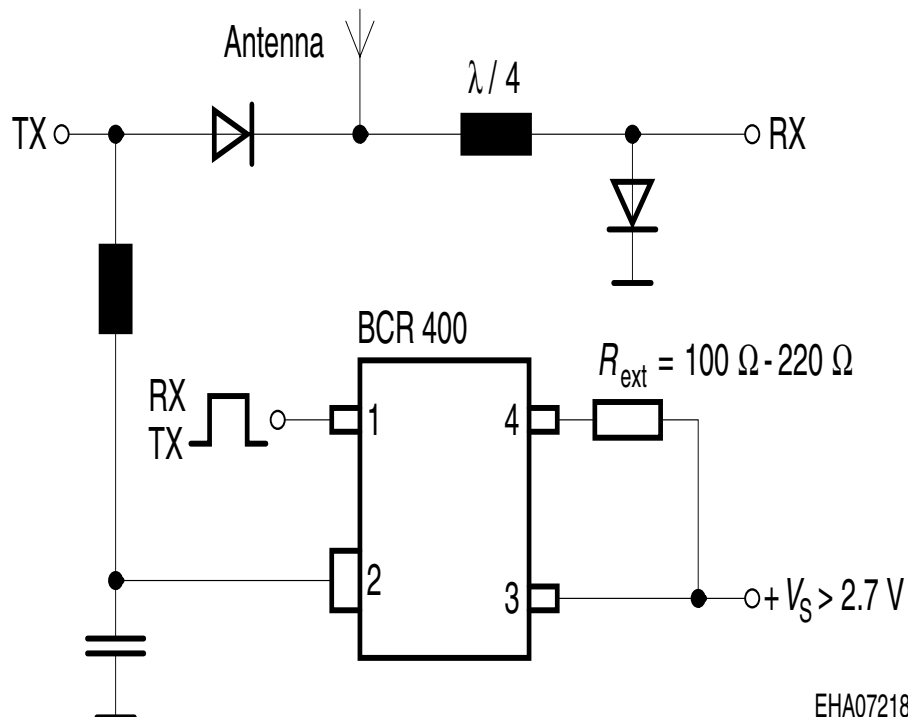

Low voltage reference

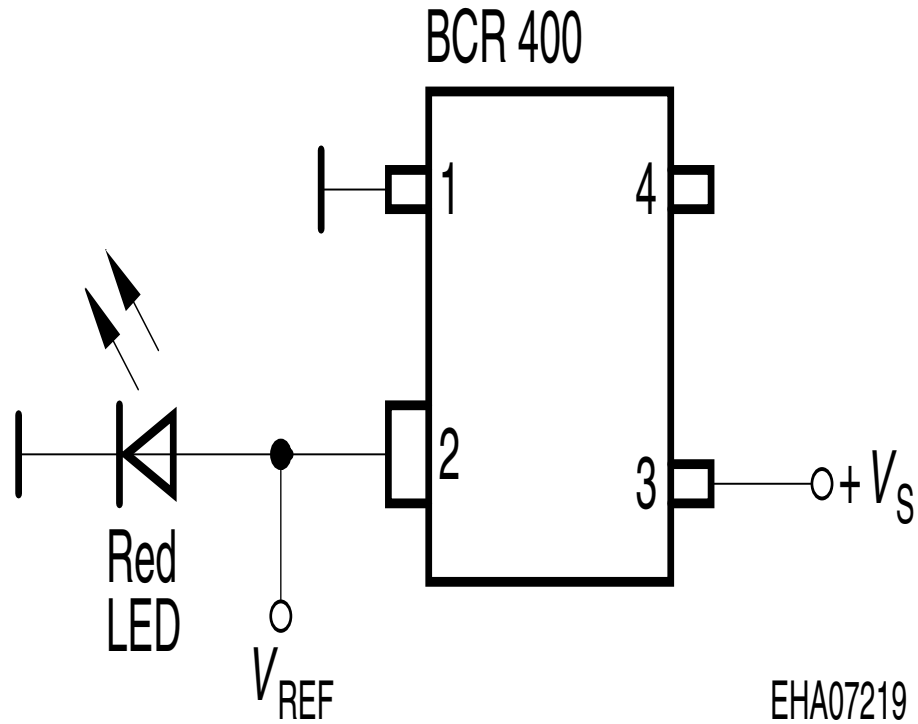

Precision timer with BCR 400 providing constant charge current

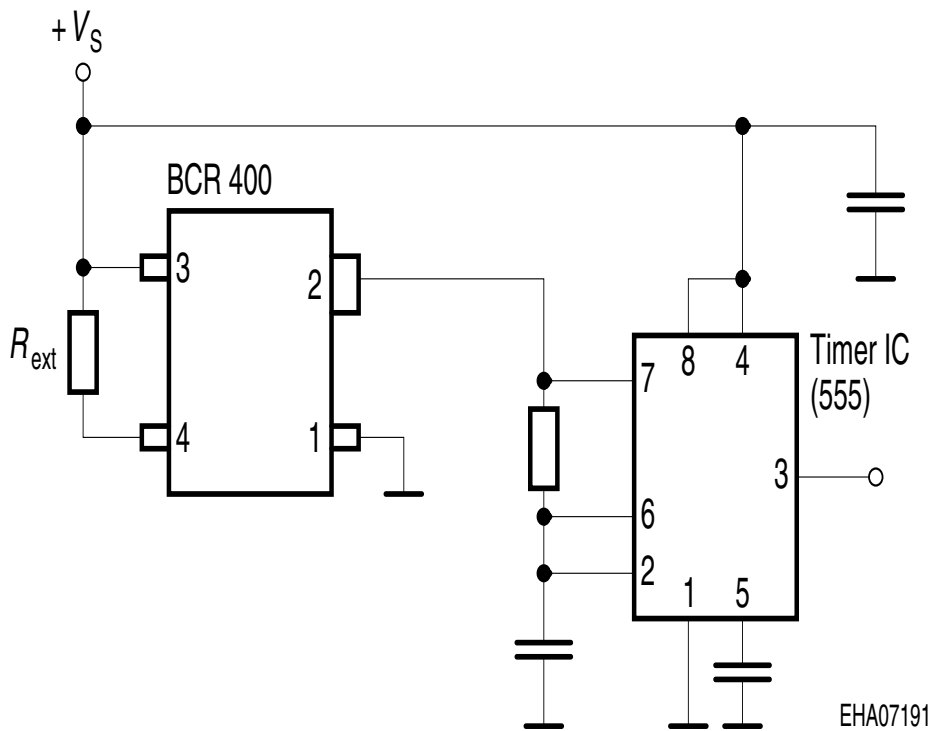



LittleDiode supplies new, hard to find or obsolete electronic components and semiconductors all over the world.

With over two million different components listed you are sure to find the part you need.

Feel free to visit us today at our online store:

LittleDiode.com

Looking forward to providing you with the best possible service.