

**PNP Silicon High-Voltage Transistors**

- Suitable for video output stages in TV sets and switching power supplies
- High breakdown voltage
- Low collector-emitter saturation voltage
- Complementary types: BFN 16, BFN 18 (NPN)

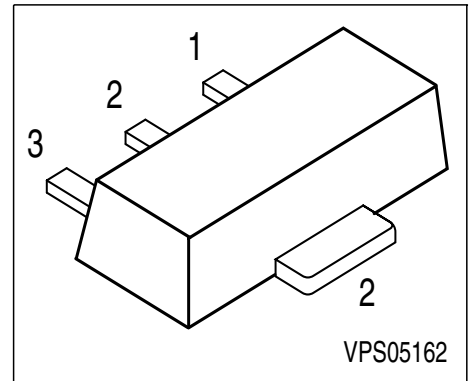

Type	Marking	Pin Configuration			Package
BFN 17	DG	1 = B	2 = C	3 = E	SOT-89
BFN 19	DH	1 = B	2 = C	3 = E	SOT-89

**Maximum Ratings**

Parameter	Symbol	BFN 17	BFN 19	Unit
Collector-emitter voltage	$V_{CEO}$	250	300	V
Collector-base voltage	$V_{CBO}$	250	300	
Emitter-base voltage	$V_{EBO}$	5	5	
DC collector current	$I_C$	200		mA
Peak collector current	$I_{CM}$	500		
Base current	$I_B$	100		
Peak base current	$I_{BM}$	200		
Total power dissipation, $T_S = 130\text{ °C}$	$P_{tot}$	1		W
Junction temperature	$T_j$	150		°C
Storage temperature	$T_{stg}$	-65 ... 150		

**Thermal Resistance**

Junction ambient <sup>1)</sup>	$R_{thJA}$	≤75	K/W
Junction - soldering point	$R_{thJS}$	≤20	K/W

1) Package mounted on pcb 40mm x 40mm x 1.5mm / 6cm<sup>2</sup> Cu

**Electrical Characteristics** at  $T_A = 25^\circ\text{C}$ , unless otherwise specified.

Parameter	Symbol	Values			Unit
		min.	typ.	max.	
<b>DC Characteristics</b>					
Collector-emitter breakdown voltage $I_C = 1\text{ mA}, I_B = 0$	$V_{(BR)CEO}$				V
BFN 17		250	-	-	
BFN 19		300	-	-	
Collector-base breakdown voltage $I_C = 100\ \mu\text{A}, I_B = 0$	$V_{(BR)CBO}$				
BFN 17		250	-	-	
BFN 19		300	-	-	
Emitter-base breakdown voltage $I_E = 100\ \mu\text{A}, I_C = 0$	$V_{(BR)EBO}$	5	-	-	
Collector cutoff current $V_{CB} = 200\text{ V}, I_E = 0$	$I_{CBO}$				nA
BFN 17		-	-	100	
$V_{CB} = 250\text{ V}, I_E = 0$	BFN 19	-	-	100	
Collector cutoff current $V_{CB} = 200\text{ V}, I_E = 0, T_A = 150^\circ\text{C}$	$I_{CBO}$				$\mu\text{A}$
BFN 17		-	-	20	
$V_{CB} = 250\text{ V}, I_E = 0, T_A = 150^\circ\text{C}$	BFN 19	-	-	20	
Emitter cutoff current $V_{EB} = 5\text{ V}, I_C = 0$	$I_{EBO}$	-	-	100	nA
DC current gain 1) $I_C = 1\text{ mA}, V_{CE} = 10\text{ V}$	$h_{FE}$	25	-	-	-
$I_C = 10\text{ mA}, V_{CE} = 10\text{ V}$		40	-	-	
BFN 17 $I_C = 30\text{ mA}, V_{CE} = 10\text{ V}$		40	-	-	
BFN 19		30	-	-	
Collector-emitter saturation voltage1) $I_C = 20\text{ mA}, I_B = 2\text{ mA}$	$V_{CEsat}$	-	-	0.4	V
BFN 19		-	-	0.5	
Base-emitter saturation voltage 1) $I_C = 20\text{ mA}, I_B = 2\text{ mA}$	$V_{BEsat}$	-	-	0.9	

 1) Pulse test:  $t < 300\ \mu\text{s}$ ;  $D < 2\%$

**Electrical Characteristics** at  $T_A = 25^\circ\text{C}$ , unless otherwise specified.

Parameter	Symbol	Values			Unit
		min.	typ.	max.	
<b>AC Characteristics</b>					
Transition frequency $I_C = 20\text{ mA}$ , $V_{CE} = 10\text{ V}$ , $f = 20\text{ MHz}$	$f_T$	-	100	-	MHz
Collector-base capacitance $V_{CB} = 30\text{ V}$ , $f = 1\text{ MHz}$	$C_{cb}$	-	2.5	-	pF

**Total power dissipation  $P_{tot} = f(T_A^*; T_S)$**

\* Package mounted on epoxy

**Operating range  $I_C = f(V_{CE0})$**

$T_A = 25^\circ\text{C}, D = 0$

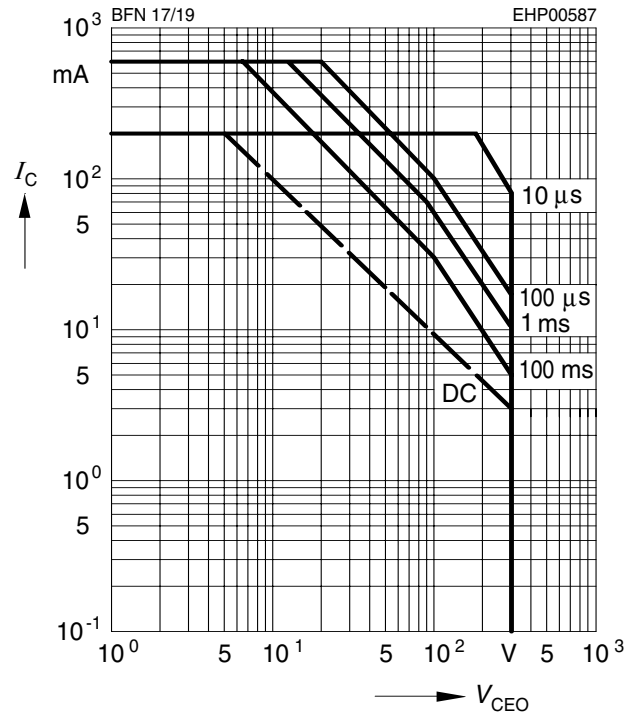
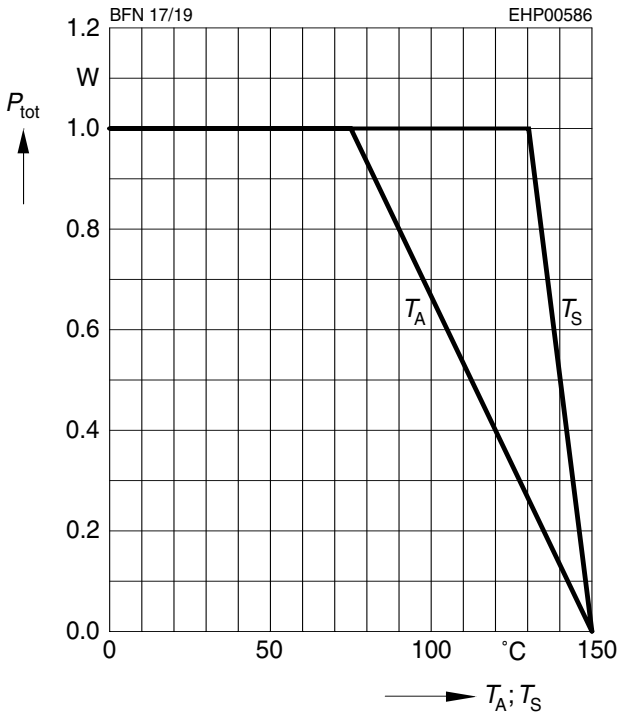

**Permissible pulse load**

$P_{totmax} / P_{totDC} = f(t_p)$

**Collector current  $I_C = f(V_{BE})$**

$V_{CE} = 10\text{V}$

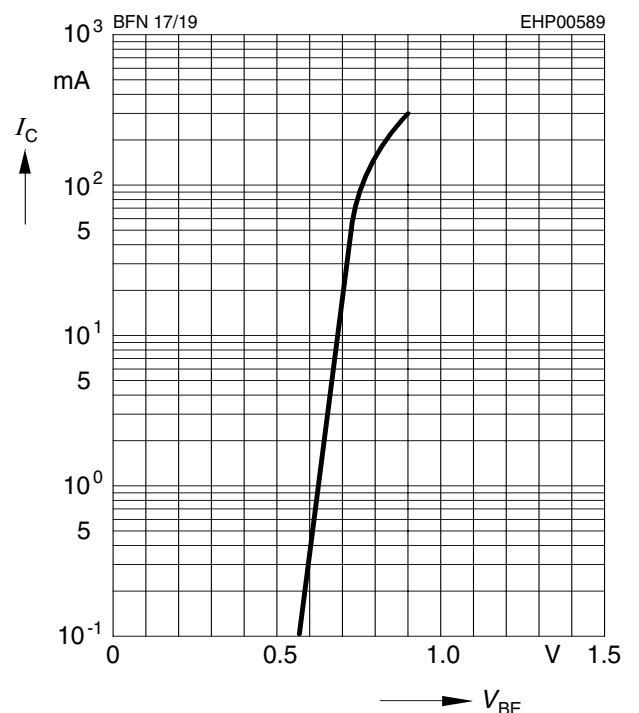
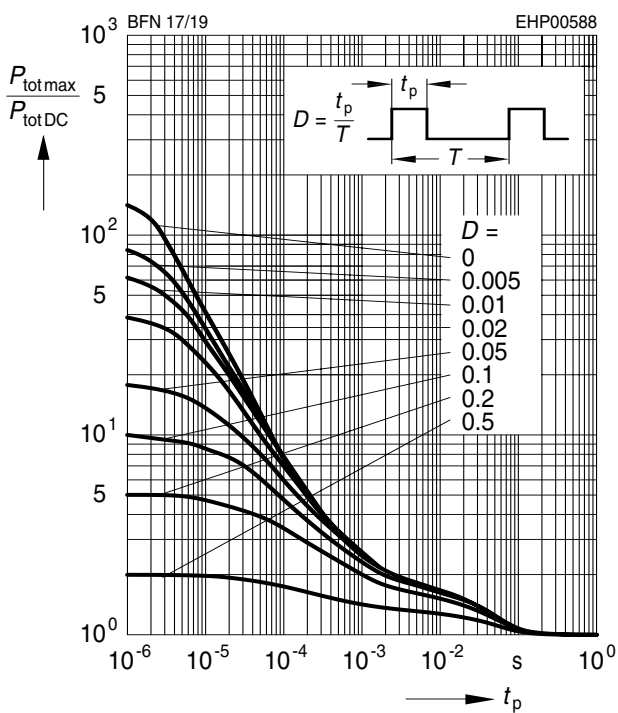

**Transition frequency  $f_T = f(I_C)$**

$V_{CE} = 10V$

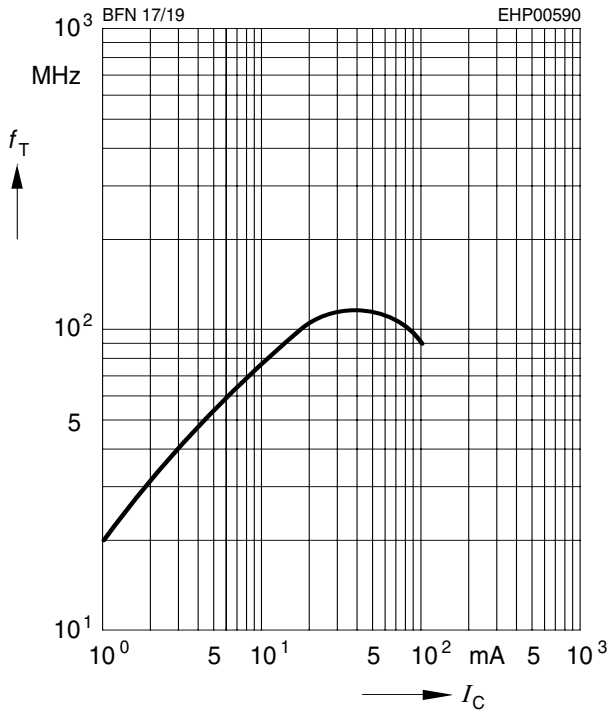

**Collector cutoff current  $I_{CBO} = f(T_A)$**

$V_{CB} = 200V$

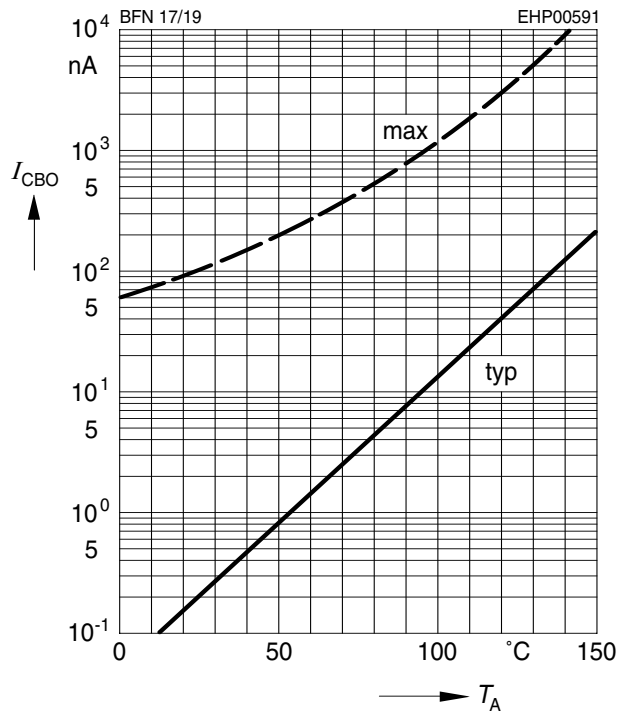

**DC current gain  $h_{FE} = f(I_C)$**

$V_{CE} = 10V$

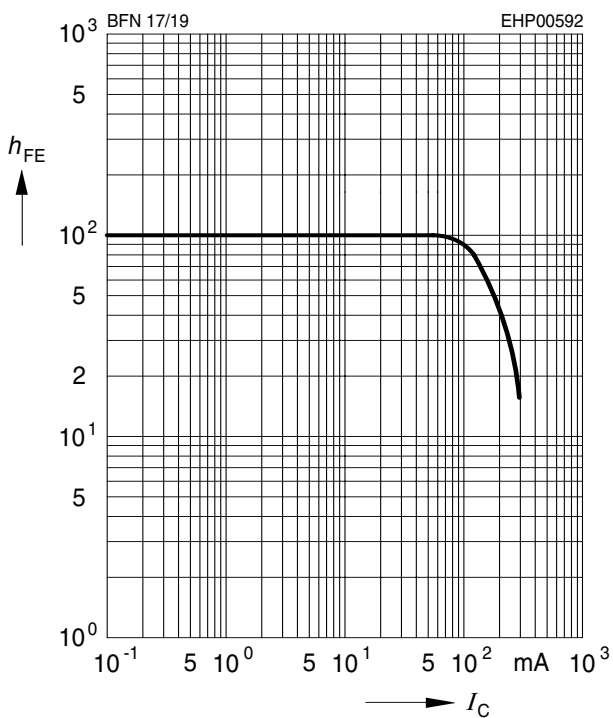



LittleDiode supplies new, hard to find or obsolete electronic components and semiconductors all over the world.

With over two million different components listed you are sure to find the part you need.

Feel free to visit us today at our online store:

[LittleDiode.com](http://LittleDiode.com)

Looking forward to providing you with the best possible service.