

## NPN Silicon RF Transistor

**BFQ 74**

- For low-noise amplifiers in the GHz range, and broadband analog and digital applications in telecommunications systems at collector currents from 1 mA to 25 mA.
- Hermetically sealed ceramic package.
- HiRel/Mil screening available.

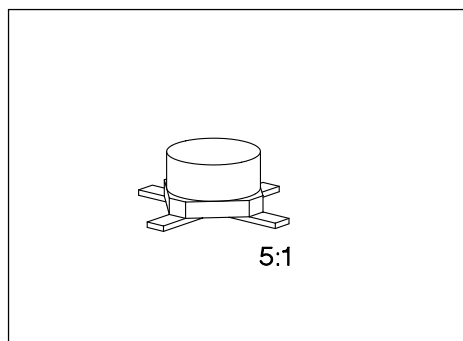

**ESD: Electrostatic discharge sensitive device, observe handling precautions!**

Type	Marking	Ordering Code (tape and reel)	Pin Configuration				Package <sup>1)</sup>
			1	2	3	4	
BFQ 74	74	Q62702-F788	B	E	C	E	Cerrec-X

### Maximum Ratings

Parameter	Symbol	Values	Unit
Collector-emitter voltage	$V_{CE0}$	16	V
Collector-emitter voltage, $V_{BE} = 0$	$V_{CES}$	25	
Collector-base voltage	$V_{CB0}$	25	
Emitter-base voltage	$V_{EB0}$	2	
Collector current	$I_C$	35	mA
Peak collector current, $f \geq 10$ MHz	$I_{CM}$	45	
Base current	$I_B$	5	
Total power dissipation, $T_S \leq 115$ °C <sup>3)</sup>	$P_{tot}$	300	mW
Junction temperature	$T_j$	175	°C
Ambient temperature range	$T_A$	- 65 ... + 175	
Storage temperature range	$T_{stg}$	- 65 ... + 175	

### Thermal Resistance

Junction - ambient <sup>2)</sup>	$R_{th JA}$	$\leq 280$	K/W
Junction - soldering point <sup>3)</sup>	$R_{th JS}$	$\leq 200$	

1) For detailed dimensions see chapter Package Outlines.

2) Package mounted on alumina 15 mm × 16.7 mm × 0.7 mm.

3)  $T_S$  is measured on the collector lead at the soldering point to the pcb.

**Electrical Characteristics**

at  $T_A = 25\text{ }^\circ\text{C}$ , unless otherwise specified.

Parameter	Symbol	Values			Unit
		min.	typ.	max.	

**DC Characteristics**

Collector-emitter breakdown voltage $I_C = 1\text{ mA}, I_B = 0$	$V_{(BR)CE0}$	16	–	–	V
Collector-emitter cutoff current $V_{CE} = 25\text{ V}, V_{BE} = 0$	$I_{CES}$	–	–	100	$\mu\text{A}$
Collector-base cutoff current $V_{CB} = 15\text{ V}, I_E = 0$	$I_{CBO}$	–	–	50	nA
Emitter-base cutoff current $V_{EB} = 2\text{ V}, I_C = 0$	$I_{EBO}$	–	–	10	$\mu\text{A}$
DC current gain $I_C = 5\text{ mA}, V_{CE} = 10\text{ V}$ $I_C = 15\text{ mA}, V_{CE} = 10\text{ V}$	$h_{FE}$	50 50	110 120	250 –	–
Collector-emitter saturation voltage $I_C = 30\text{ mA}, I_B = 3\text{ mA}$	$V_{CEsat}$	–	0.13	0.3	V
Base-emitter voltage $I_C = 10\text{ mA}, V_{CE} = 10\text{ V}$	$V_{BE}$	–	0.78	–	

## Electrical Characteristics

at  $T_A = 25\text{ °C}$ , unless otherwise specified.

Parameter	Symbol	Values			Unit
		min.	typ.	max.	

## AC Characteristics

Transition frequency $I_C = 5\text{ mA}$ , $V_{CE} = 10\text{ V}$ , $f = 200\text{ MHz}$ $I_C = 15\text{ mA}$ , $V_{CE} = 10\text{ V}$ , $f = 200\text{ MHz}$	$f_t$	–	4.4 6	–	GHz
Collector-base capacitance $V_{CB} = 10\text{ V}$ , $V_{BE} = v_{be} = 0$ , $f = 1\text{ MHz}$	$C_{cb}$	–	0.3	0.4	pF
Collector-emitter capacitance $V_{CE} = 10\text{ V}$ , $V_{BE} = v_{be} = 0$ , $f = 1\text{ MHz}$	$C_{ce}$	–	0.4	–	
Input capacitance $V_{EB} = 0.5\text{ V}$ , $I_C = i_c = 0$ , $f = 1\text{ MHz}$	$C_{ibo}$	–	1.35	–	
Output capacitance $V_{CE} = 10\text{ V}$ , $V_{BE} = v_{be} = 0$ , $f = 1\text{ MHz}$	$C_{obs}$	–	0.7	–	
Noise figure $I_C = 3\text{ mA}$ , $V_{CE} = 10\text{ V}$ , $f = 10\text{ MHz}$ , $Z_S = 75\text{ }\Omega$ $I_C = 5\text{ mA}$ , $V_{CE} = 10\text{ V}$ , $f = 800\text{ MHz}$ , $Z_S = 50\text{ }\Omega$ $I_C = 10\text{ mA}$ , $V_{CE} = 10\text{ V}$ , $f = 2\text{ GHz}$ , $Z_S = Z_{Sopt}$	$F$	–	0.9 1.4 2.5	– – 2.9	dB
Power gain $I_C = 15\text{ mA}$ , $V_{CE} = 10\text{ V}$ , $f = 2\text{ GHz}$ , $Z_0 = 50\text{ }\Omega$ $I_C = 15\text{ mA}$ , $V_{CE} = 10\text{ V}$ , $f = 4\text{ GHz}$ , $Z_0 = 50\text{ }\Omega$	$G_{ma}^{1)}$ $G_{rms}^{2)}$	–	14 9.8	– –	
Transducer gain $I_C = 15\text{ mA}$ , $V_{CE} = 10\text{ V}$ , $f = 2\text{ GHz}$ , $Z_0 = 50\text{ }\Omega$	$ S_{21e} ^2$	–	9.8	–	
Linear output voltage two-tone intermodulation test $I_C = 25\text{ mA}$ , $V_{CE} = 10\text{ V}$ , $d_{IM} = 60\text{ dB}$ , $f_1 = 806\text{ MHz}$ , $f_2 = 810\text{ MHz}$ , $Z_S = Z_L = 50\text{ }\Omega$	$V_{o1} = V_{o2}$	–	160	–	mV
Third order intercept point $I_C = 25\text{ mA}$ , $V_{CE} = 10\text{ V}$ , $f = 800\text{ MHz}$	$IP_3$	–	27	–	dBm

$$1) \quad \left| \frac{S_{21e}}{S_{12e}} \right| (k - \sqrt{k^2 - 1})$$

$$2) \quad \left| \frac{S_{21e}}{S_{12e}} \right|$$

### Total power dissipation $P_{tot} = f(T_A^*; T_S)$

\*Package mounted on alumina

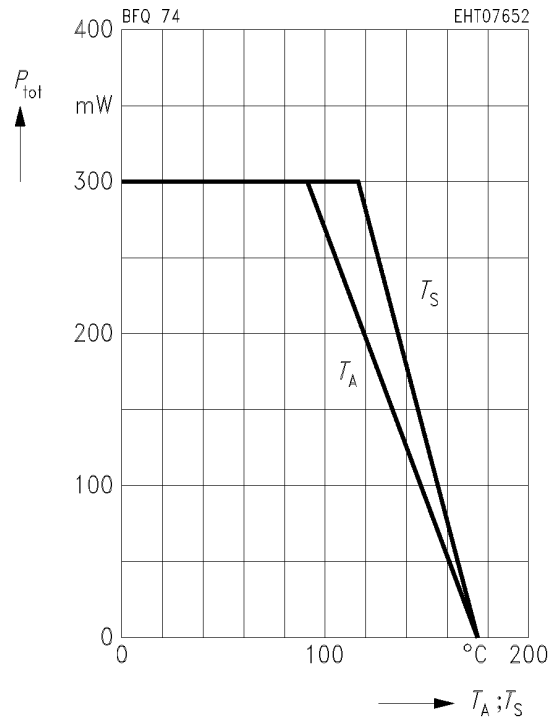

### Transition frequency $f_T = f(I_C)$

$f = 200$  MHz

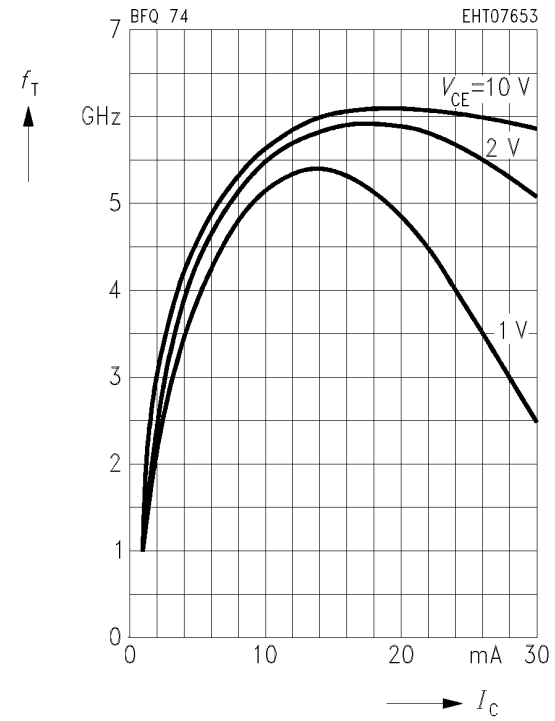

### Collector-base capacitance $C_{cb} = f(V_{CB})$

$V_{BE} = v_{be} = 0, f = 1$  MHz

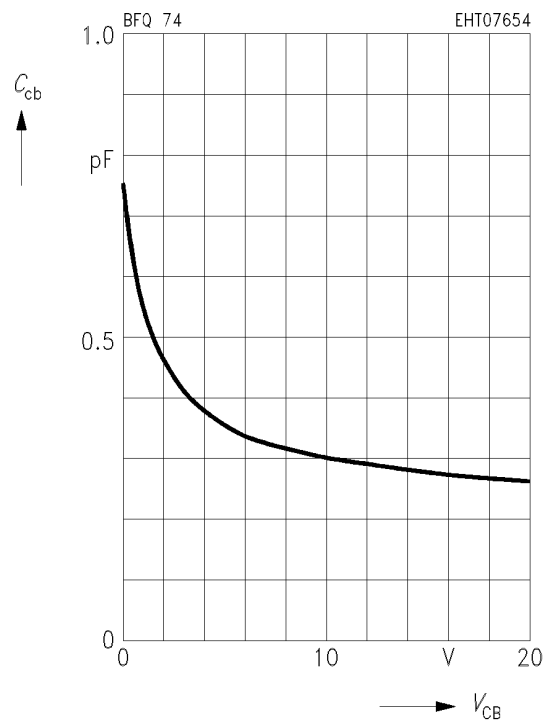

### Common Emitter Noise Parameters

$f$	$F_{min}$	$G_p(F_{min})$	$\Gamma_{opt}$		$R_N$	$N$	$F_{50\Omega}$	$G_p(F_{50\Omega})$
GHz	dB	dB	MAG	ANG	$\Omega$	-	dB	dB

$I_C = 3\text{ mA}, V_{CE} = 10\text{ V}, Z_0 = 50\ \Omega$

0.01	0.7	-	(Z <sub>s</sub> = 150 $\Omega$ )		-	-	1.2	-
------	-----	---	----------------------------------	--	---	---	-----	---

$I_C = 10\text{ mA}, V_{CE} = 10\text{ V}, Z_0 = 50\ \Omega$

0.01	1.05	-	(Z <sub>s</sub> = 75 $\Omega$ )		-	-	1.2	-
0.8	1.3	17.5	0.22	82	11.5	0.20	1.4	16.8
2.0	2.5	11.5	0.20	137	23.5	0.60	2.7	10

### Noise figure $F = f(I_C)$

$V_{CE} = 10\text{ V}, f = 10\text{ MHz}$

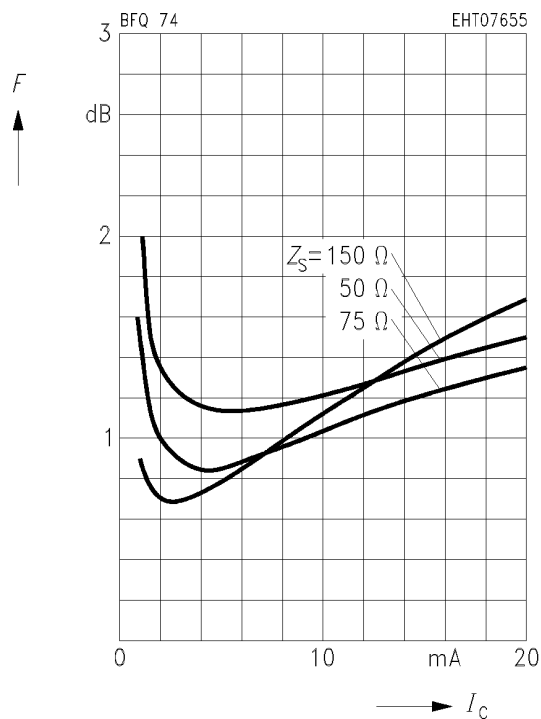

**Circles of constant noise figure  $F = f(Z_S)$  and available power gain  $G_{av} = f(Z_S)$**

$I_C = 10 \text{ mA}$ ,  $V_{CE} = 10 \text{ V}$ ,  $f = 800 \text{ MHz}$

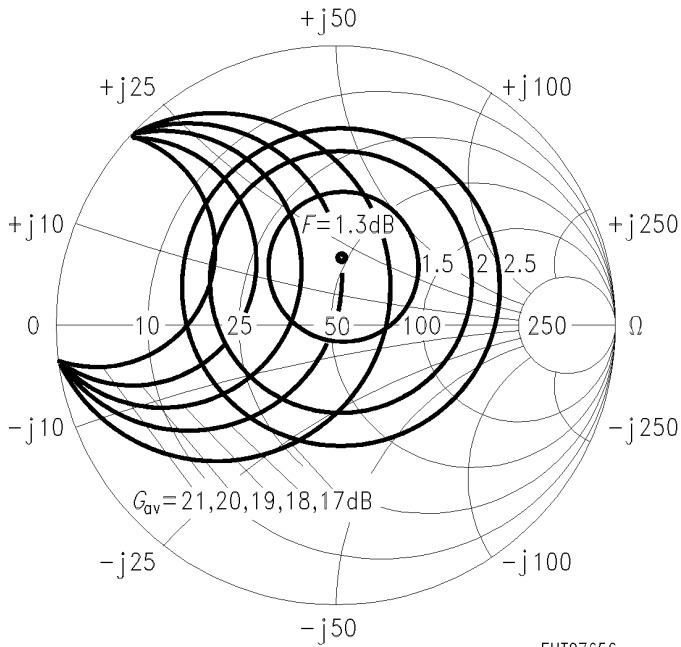

EHT07656

**Noise figure  $F = f(I_C)$**

**Power gain  $G = f(I_C)$**

$V_{CE} = 10 \text{ V}$ ,  $f = 800 \text{ MHz}$ ,  $Z_{Lopt} (G)$

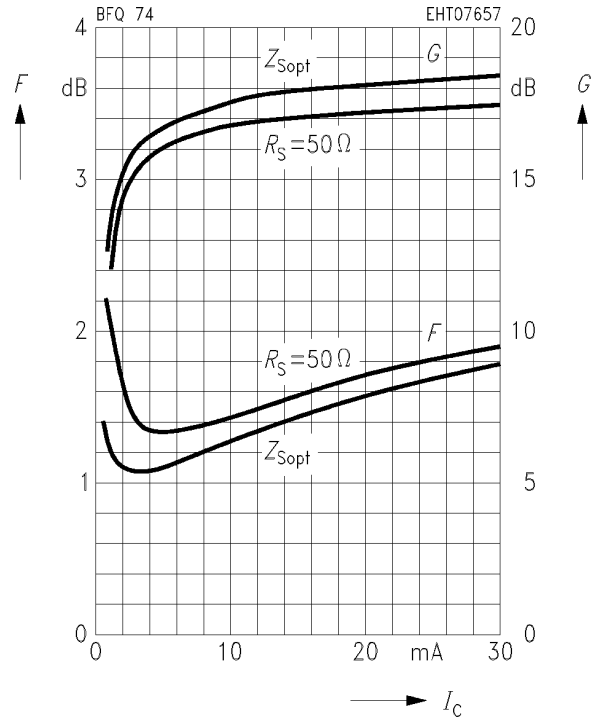

**Circles of constant noise figure  $F = f(Z_S)$  and available power gain  $G_{av} = f(Z_S)$**

$I_C = 10 \text{ mA}$ ,  $V_{CE} = 10 \text{ V}$ ,  $f = 2 \text{ GHz}$

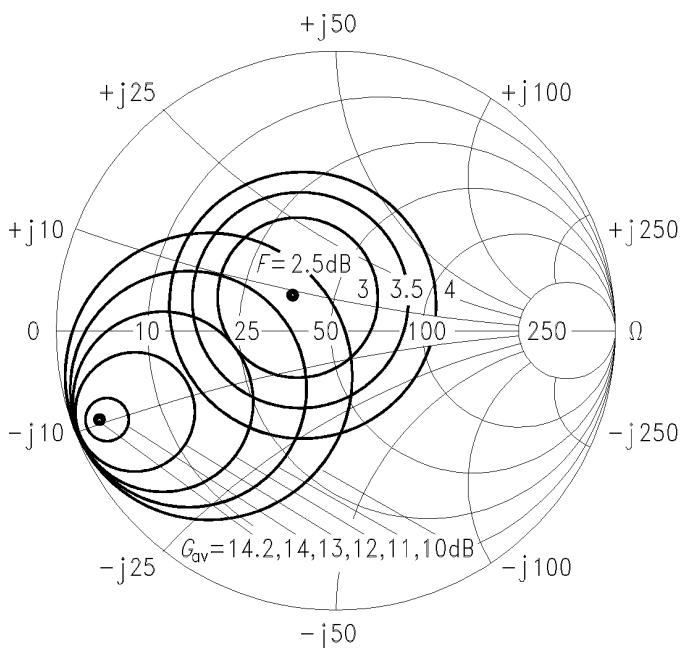

EHT07658

**Noise figure  $F = f(I_C)$**

**Power gain  $G = f(I_C)$**

$V_{CE} = 10 \text{ V}$ ,  $f = 2 \text{ GHz}$ ,  $Z_{Lopt} (G)$

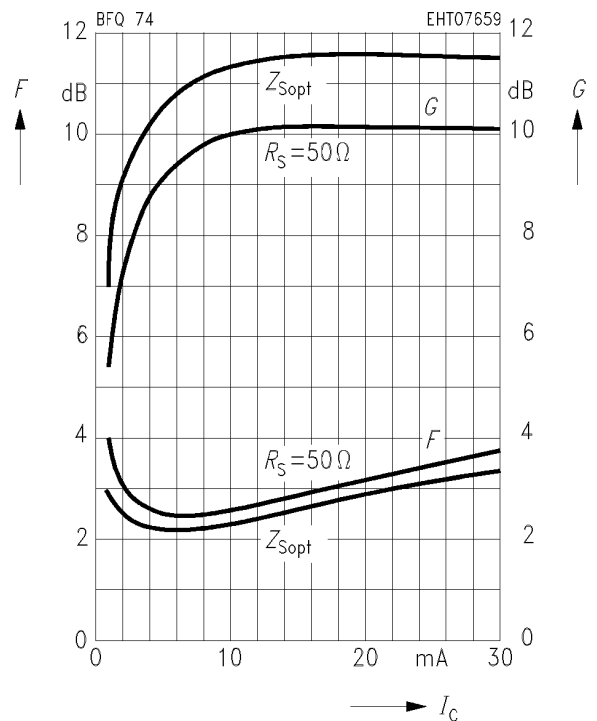

**Common Emitter Power Gain**

**Power gain  $G_{ms}$ ,  $|S_{21e}|^2 = f(I_C)$**

$V_{CE} = 10\text{ V}$ ,  $f = 1\text{ GHz}$ ,  $Z_0 = 50\ \Omega$

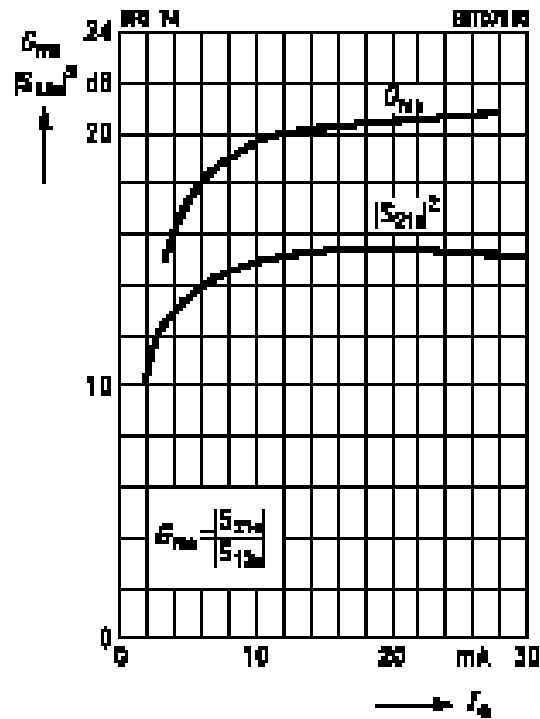

**Power gain  $G_{ma}$ ,  $|S_{21e}|^2 = f(I_C)$**

$V_{CE} = 10\text{ V}$ ,  $f = 2\text{ GHz}$ ,  $Z_0 = 50\ \Omega$

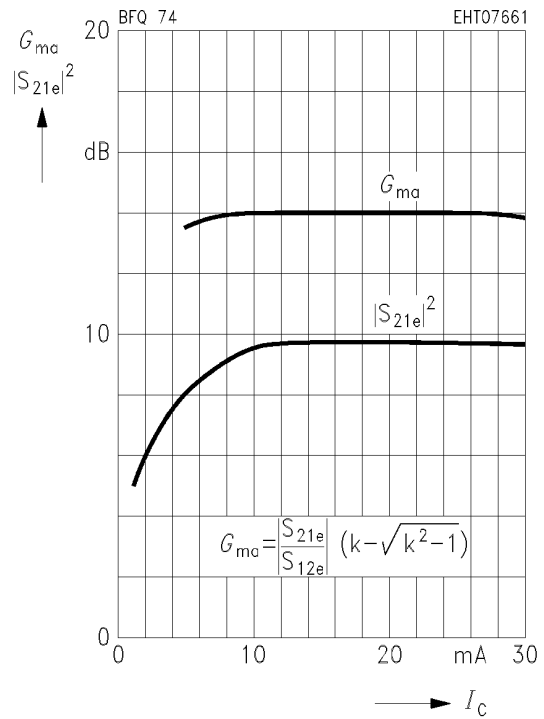

**Power gain  $G_{ms}$ ,  $|S_{21e}|^2 = f(I_C)$**

$V_{CE} = 10\text{ V}$ ,  $f = 4\text{ GHz}$ ,  $Z_0 = 50\ \Omega$

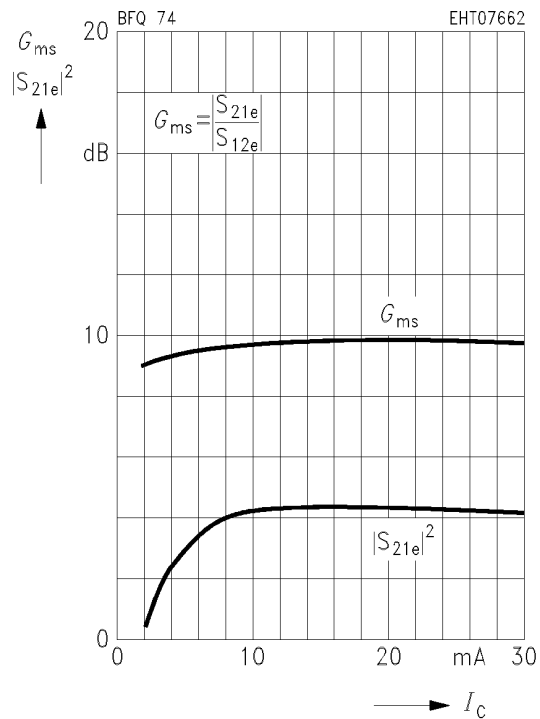

**Power gain  $G_{ma}, G_{ms}, |S_{21e}|^2 = f(f)$**   
 $I_C = 2 \text{ mA}, V_{CE} = 10 \text{ V}, Z_0 = 50 \Omega$

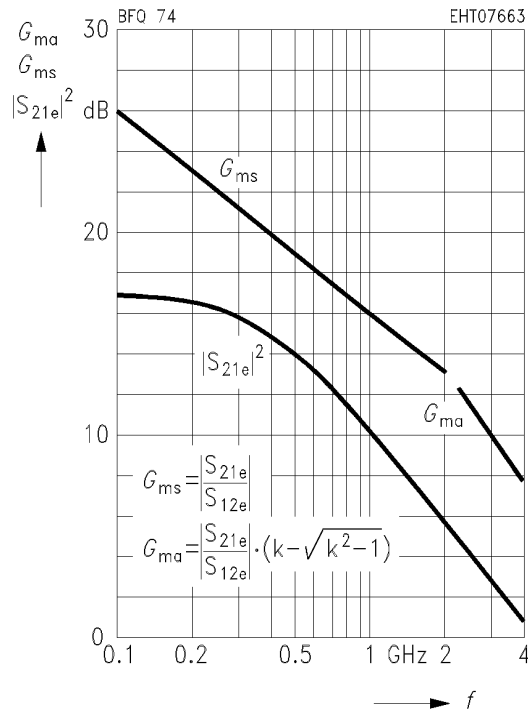

**Power gain  $G_{ma}, G_{ms}, |S_{21e}|^2 = f(f)$**   
 $I_C = 5 \text{ mA}, V_{CE} = 10 \text{ V}, Z_0 = 50 \Omega$

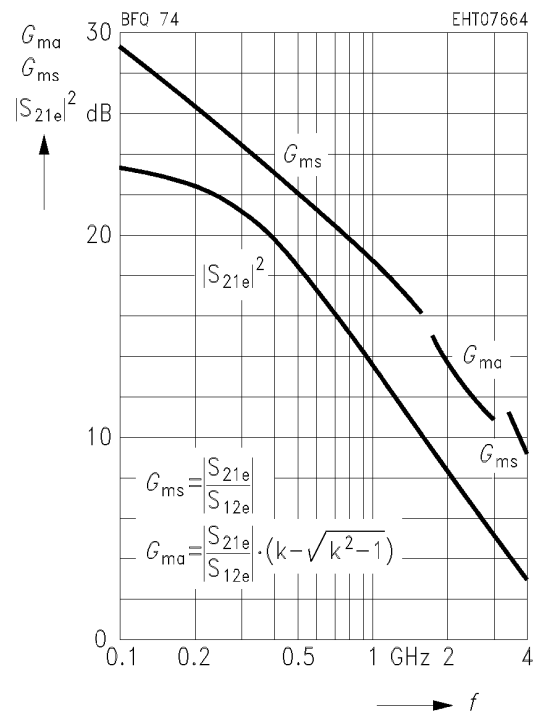

**Power gain  $G_{ma}, G_{ms}, |S_{21e}|^2 = f(f)$**   
 $I_C = 10 \text{ mA}, V_{CE} = 10 \text{ V}, Z_0 = 50 \Omega$

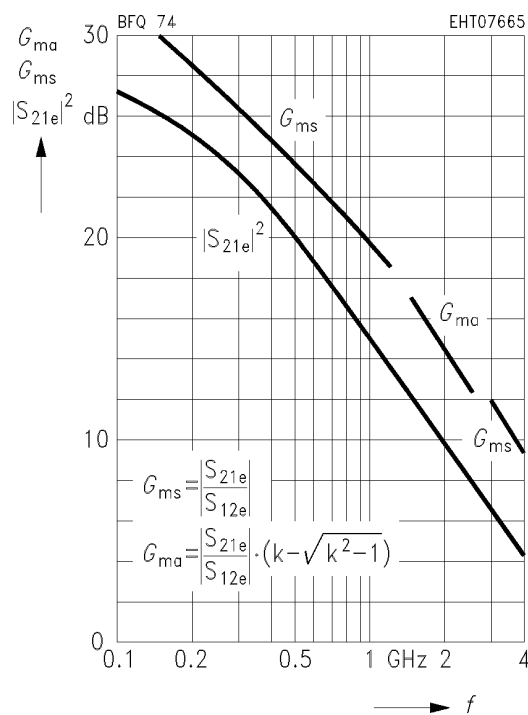

**Power gain  $G_{ma}, G_{ms}, |S_{21e}|^2 = f(f)$**   
 $I_C = 25 \text{ mA}, V_{CE} = 10 \text{ V}, Z_0 = 50 \Omega$

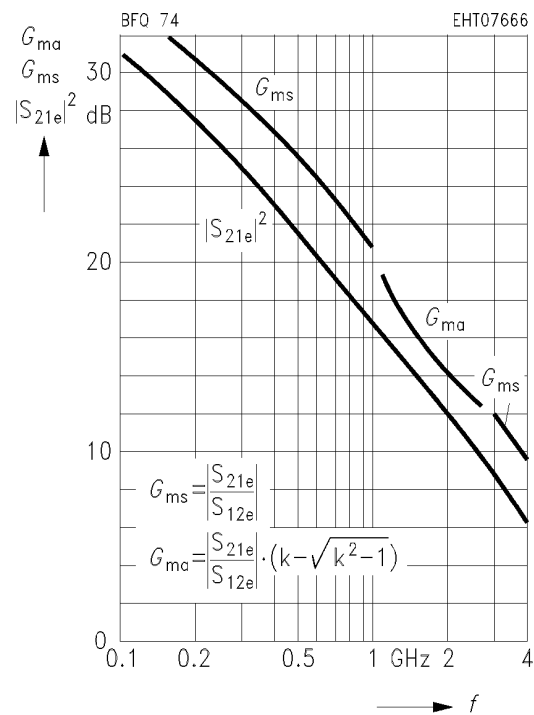

### Common Emitter S Parameters

$f$	$S_{11}$		$S_{21}$		$S_{12}$		$S_{22}$	
	MAG	ANG	MAG	ANG	MAG	ANG	MAG	ANG

$I_C = 2 \text{ mA}$ ,  $V_{CE} = 10 \text{ V}$ ,  $Z_0 = 50 \Omega$

0.1	0.96	- 16	6.83	169	0.017	79	0.99	- 5
0.2	0.93	- 33	6.61	155	0.034	70	0.96	- 11
0.3	0.88	- 50	6.18	144	0.049	62	0.92	- 16
0.4	0.84	- 64	5.62	134	0.060	54	0.88	- 20
0.6	0.77	- 89	4.78	118	0.076	43	0.81	- 26
0.8	0.71	- 110	3.98	104	0.085	34	0.74	- 31
1.0	0.68	- 127	3.41	93	0.089	29	0.70	- 34
1.2	0.65	- 141	2.95	84	0.091	25	0.67	- 37
1.5	0.63	- 158	2.45	72	0.091	22	0.64	- 41
1.8	0.63	- 172	2.10	62	0.092	21	0.63	- 46
2.0	0.63	179	1.91	55	0.091	21	0.61	- 49
2.5	0.64	161	1.58	41	0.092	24	0.59	- 60
3.0	0.66	145	1.36	28	0.099	29	0.59	- 71
3.5	0.68	133	1.20	15	0.113	34	0.58	- 83
4.0	0.68	118	1.07	3	0.136	35	0.58	- 97
4.5	0.71	107	0.96	- 8	0.160	34	0.58	- 111
5.0	0.72	95	0.85	- 18	0.190	29	0.60	- 127

$S_{11}, S_{22} = f(f)$

$I_C = 2 \text{ mA}$ ,  $V_{CE} = 10 \text{ V}$ ,  $Z_0 = 50 \Omega$

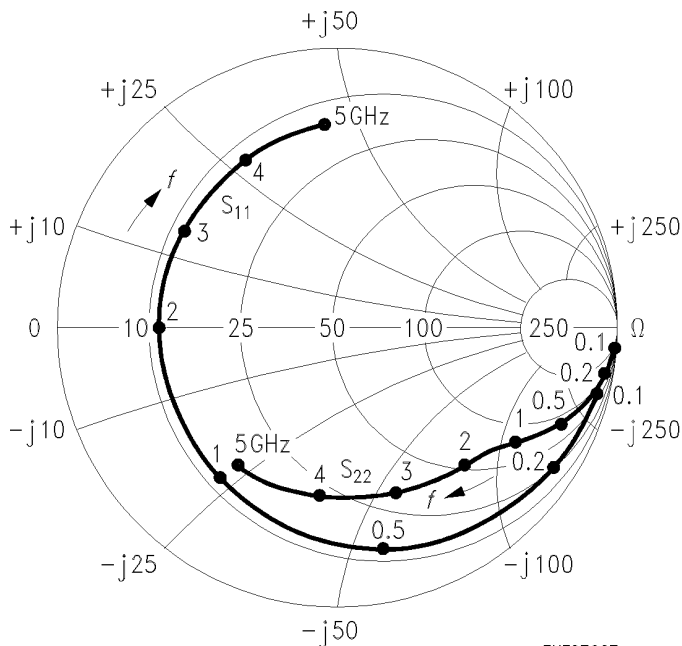

EHT07667

$S_{12}, S_{21} = f(f)$

$I_C = 2 \text{ mA}$ ,  $V_{CE} = 10 \text{ V}$ ,  $Z_0 = 50 \Omega$

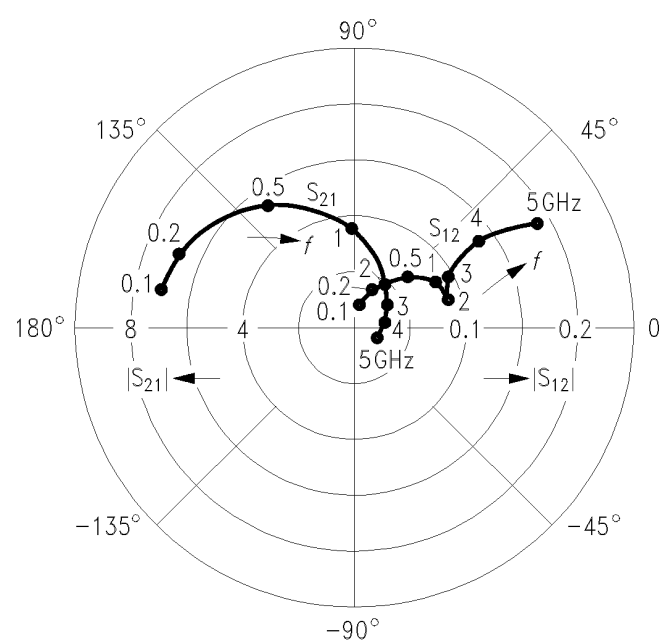

EHT07668

Common Emitter S Parameters (continued)

<i>f</i>	<i>S</i> <sub>11</sub>		<i>S</i> <sub>21</sub>		<i>S</i> <sub>12</sub>		<i>S</i> <sub>22</sub>		
	GHZ	MAG	ANG	MAG	ANG	MAG	ANG	MAG	ANG
<i>I</i> <sub>C</sub> = 5 mA, <i>V</i> <sub>CE</sub> = 10 V, <i>Z</i> <sub>0</sub> = 50 Ω									
0.1	0.91	- 25	14.67	163	0.017	78	0.97	- 9	
0.2	0.83	- 51	13.37	145	0.031	63	0.89	- 18	
0.3	0.75	- 72	11.62	131	0.040	54	0.80	- 24	
0.4	0.70	- 89	9.90	121	0.047	47	0.73	- 28	
0.6	0.63	- 115	7.61	105	0.056	41	0.64	- 32	
0.8	0.58	- 135	5.97	94	0.061	37	0.58	- 34	
1.0	0.57	- 150	4.92	85	0.064	36	0.54	- 36	
1.2	0.56	- 162	4.18	77	0.068	36	0.52	- 37	
1.5	0.55	- 176	3.40	68	0.073	37	0.50	- 41	
1.8	0.56	173	2.87	59	0.080	38	0.49	- 45	
2.0	0.57	166	2.60	53	0.084	39	0.47	- 48	
2.5	0.59	152	2.13	41	0.098	41	0.46	- 58	
3.0	0.61	138	1.83	29	0.116	41	0.45	- 68	
3.5	0.63	128	1.61	17	0.135	41	0.44	- 80	
4.0	0.64	114	1.44	5	0.161	37	0.45	- 94	
4.5	0.68	104	1.29	- 6	0.183	33	0.44	- 108	
5.0	0.68	93	1.16	- 16	0.209	27	0.46	- 124	

*S*<sub>11</sub>, *S*<sub>22</sub> = *f* (*f*)

*I*<sub>C</sub> = 5 mA, *V*<sub>CE</sub> = 10 V, *Z*<sub>0</sub> = 50 Ω

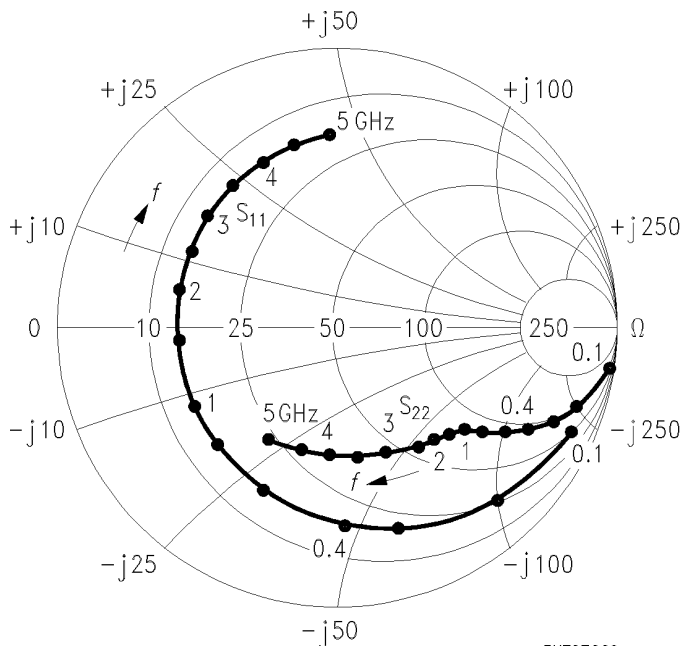

EHT07669

*S*<sub>12</sub>, *S*<sub>21</sub> = *f* (*f*)

*I*<sub>C</sub> = 5 mA, *V*<sub>CE</sub> = 10 V, *Z*<sub>0</sub> = 50 Ω

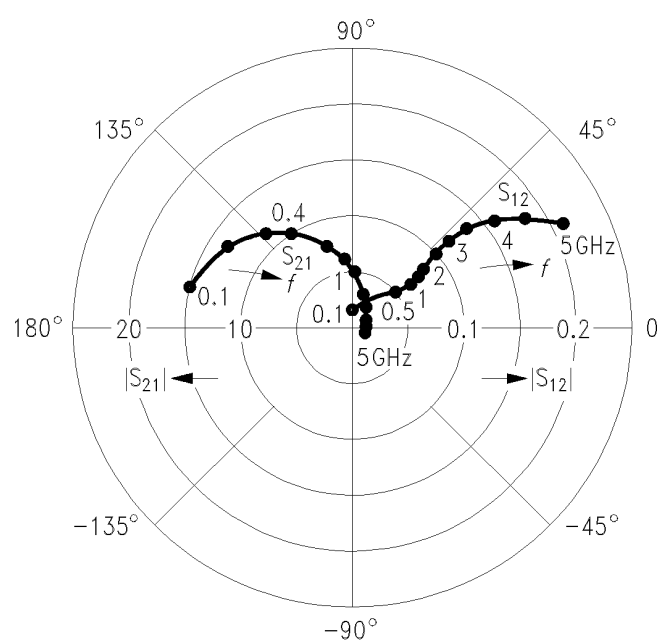

EHT07670

**Common Emitter S Parameters (continued)**

<i>f</i>	<i>S</i> <sub>11</sub>		<i>S</i> <sub>21</sub>		<i>S</i> <sub>12</sub>		<i>S</i> <sub>22</sub>	
	<b>GHZ</b>	<b>MAG</b>	<b>ANG</b>	<b>MAG</b>	<b>ANG</b>	<b>MAG</b>	<b>ANG</b>	<b>MAG</b>

*I*<sub>C</sub> = 10 mA, *V*<sub>CE</sub> = 10 V, *Z*<sub>0</sub> = 50 Ω

0.1	0.83	- 35	22.64	155	0.015	70	0.92	- 13
0.2	0.71	- 65	18.55	134	0.026	59	0.80	- 23
0.3	0.63	- 89	14.98	121	0.034	53	0.70	- 27
0.4	0.58	- 105	12.22	112	0.039	48	0.63	- 30
0.6	0.55	- 130	8.96	98	0.047	46	0.54	- 32
0.8	0.52	- 148	6.91	89	0.053	44	0.49	- 34
1.0	0.53	- 161	5.64	81	0.058	45	0.46	- 35
1.2	0.52	- 171	4.76	75	0.064	45	0.44	- 37
1.5	0.52	176	3.87	65	0.072	46	0.43	- 40
1.8	0.53	167	3.25	57	0.083	46	0.42	- 44
2.0	0.55	161	2.95	52	0.089	47	0.41	- 47
2.5	0.57	148	2.41	40	0.107	46	0.39	- 56
3.0	0.60	135	2.06	29	0.127	43	0.38	- 67
3.5	0.62	125	1.82	18	0.148	41	0.37	- 78
4.0	0.63	112	1.62	6	0.173	36	0.37	- 92
4.5	0.67	103	1.46	- 5	0.194	32	0.37	- 106
5.0	0.67	92	1.32	- 15	0.217	25	0.38	- 123

*S*<sub>11</sub>, *S*<sub>22</sub> = *f* (*f*)

*I*<sub>C</sub> = 10 mA, *V*<sub>CE</sub> = 10 V, *Z*<sub>0</sub> = 50 Ω

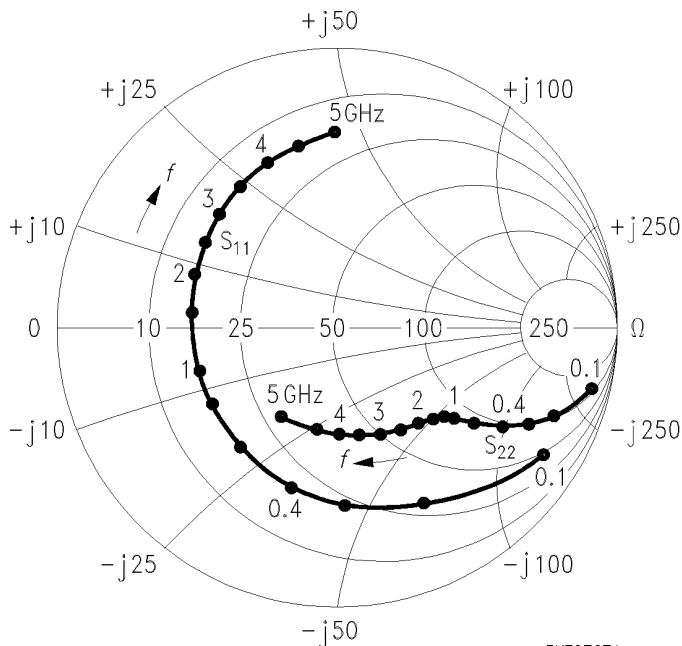

EHT07671

*S*<sub>12</sub>, *S*<sub>21</sub> = *f* (*f*)

*I*<sub>C</sub> = 10 mA, *V*<sub>CE</sub> = 10 V, *Z*<sub>0</sub> = 50 Ω

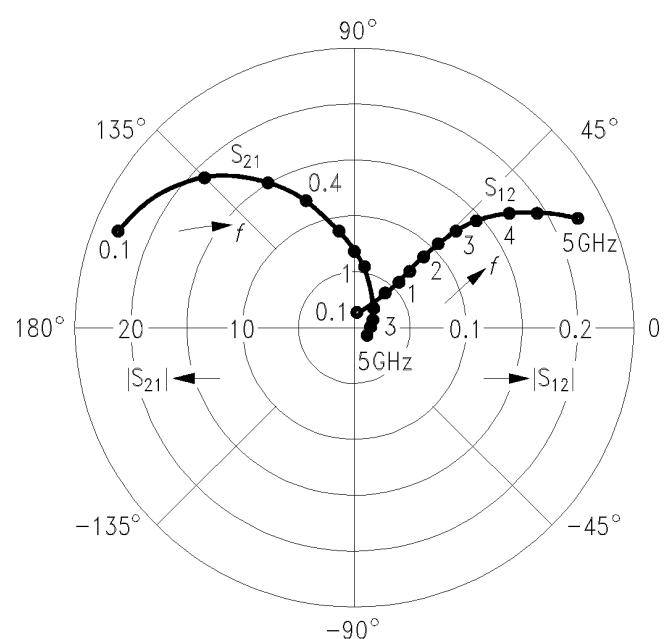

EHT07672

Common Emitter S Parameters (continued)

<i>f</i>	<i>S</i> <sub>11</sub>		<i>S</i> <sub>21</sub>		<i>S</i> <sub>12</sub>		<i>S</i> <sub>22</sub>	
	MAG	ANG	MAG	ANG	MAG	ANG	MAG	ANG
0.1	0.79	- 44	29.12	151	0.015	66	0.89	- 17
0.2	0.66	- 81	22.58	128	0.023	56	0.73	- 27
0.3	0.59	- 107	17.37	115	0.028	50	0.61	- 30
0.4	0.55	- 123	13.71	106	0.033	48	0.55	- 31
0.6	0.52	- 145	9.66	93	0.039	48	0.48	- 31
0.8	0.51	- 161	7.32	85	0.045	50	0.44	- 32
1.0	0.52	- 171	5.92	78	0.051	51	0.42	- 33
1.2	0.51	179	4.97	72	0.058	52	0.41	- 34
1.5	0.51	169	4.02	63	0.068	53	0.40	- 37
1.8	0.53	161	3.36	56	0.080	53	0.39	- 42
2.0	0.54	156	3.04	51	0.087	52	0.38	- 45
2.5	0.56	145	2.49	39	0.107	51	0.37	- 54
3.0	0.59	133	2.12	28	0.128	47	0.36	- 65
3.5	0.62	123	1.87	17	0.151	44	0.35	- 77
4.0	0.63	111	1.67	6	0.176	38	0.35	- 91
4.5	0.66	102	1.50	- 5	0.198	33	0.35	- 106
5.0	0.67	91	1.35	- 15	0.222	26	0.36	- 122

*I*<sub>C</sub> = 15 mA, *V*<sub>CE</sub> = 10 V, *Z*<sub>0</sub> = 50 Ω

*S*<sub>11</sub>, *S*<sub>22</sub> = *f* (*f*)

*I*<sub>C</sub> = 15 mA, *V*<sub>CE</sub> = 10 V, *Z*<sub>0</sub> = 50 Ω

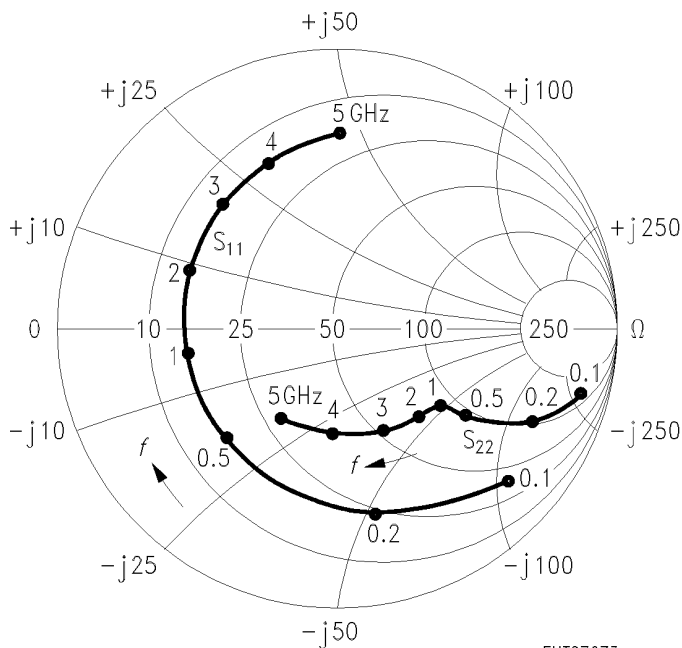

EHT07673

*S*<sub>12</sub>, *S*<sub>21</sub> = *f* (*f*)

*I*<sub>C</sub> = 15 mA, *V*<sub>CE</sub> = 10 V, *Z*<sub>0</sub> = 50 Ω

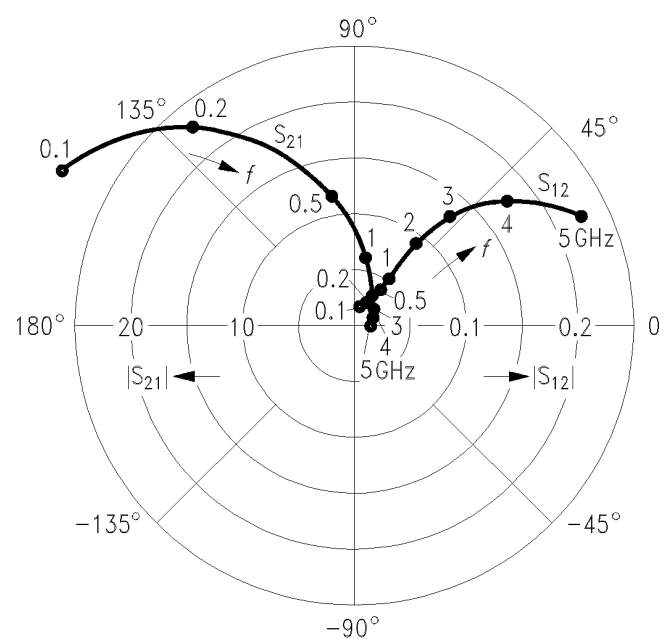

EHT07674

Common Emitter S Parameters (continued)

<i>f</i>	<i>S</i> <sub>11</sub>		<i>S</i> <sub>21</sub>		<i>S</i> <sub>12</sub>		<i>S</i> <sub>22</sub>		
	GHz	MAG	ANG	MAG	ANG	MAG	ANG	MAG	ANG
<i>I</i> <sub>C</sub> = 20 mA, <i>V</i> <sub>CE</sub> = 10 V, <i>Z</i> <sub>0</sub> = 50 Ω									
0.1	0.73	- 51	32.84	147	0.013	69	0.86	- 18	
0.2	0.61	- 89	24.03	124	0.021	55	0.69	- 27	
0.3	0.56	- 115	18.02	111	0.026	50	0.58	- 29	
0.4	0.53	- 130	14.07	103	0.030	49	0.52	- 30	
0.6	0.51	- 151	9.80	91	0.036	51	0.46	- 30	
0.8	0.50	- 165	7.40	83	0.043	53	0.43	- 30	
1.0	0.51	- 174	5.97	76	0.050	54	0.41	- 31	
1.2	0.51	176	5.01	71	0.057	55	0.40	- 33	
1.5	0.51	167	4.04	62	0.068	56	0.39	- 36	
1.8	0.53	159	3.38	55	0.080	55	0.39	- 41	
2.0	0.55	154	3.06	50	0.087	54	0.38	- 44	
2.5	0.57	143	2.50	39	0.108	52	0.36	- 53	
3.0	0.59	132	2.13	28	0.130	48	0.36	- 64	
3.5	0.62	123	1.87	17	0.152	45	0.34	- 76	
4.0	0.63	110	1.67	5	0.178	39	0.35	- 90	
4.5	0.67	101	1.50	- 5	0.199	34	0.34	- 105	
5.0	0.68	91	1.35	- 15	0.224	27	0.36	- 122	

*S*<sub>11</sub>, *S*<sub>22</sub> = *f* (*f*)

*I*<sub>C</sub> = 20 mA, *V*<sub>CE</sub> = 10 V, *Z*<sub>0</sub> = 50 Ω

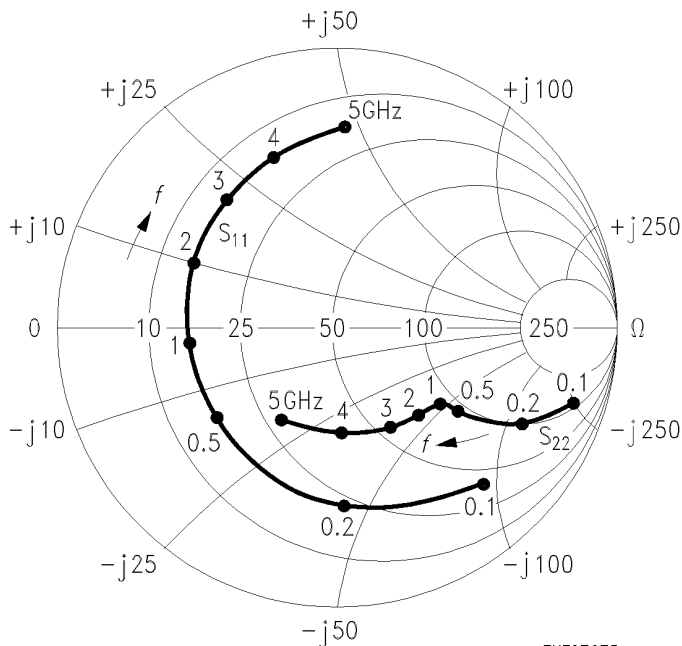

EHT07675

*S*<sub>12</sub>, *S*<sub>21</sub> = *f* (*f*)

*I*<sub>C</sub> = 20 mA, *V*<sub>CE</sub> = 10 V, *Z*<sub>0</sub> = 50 Ω

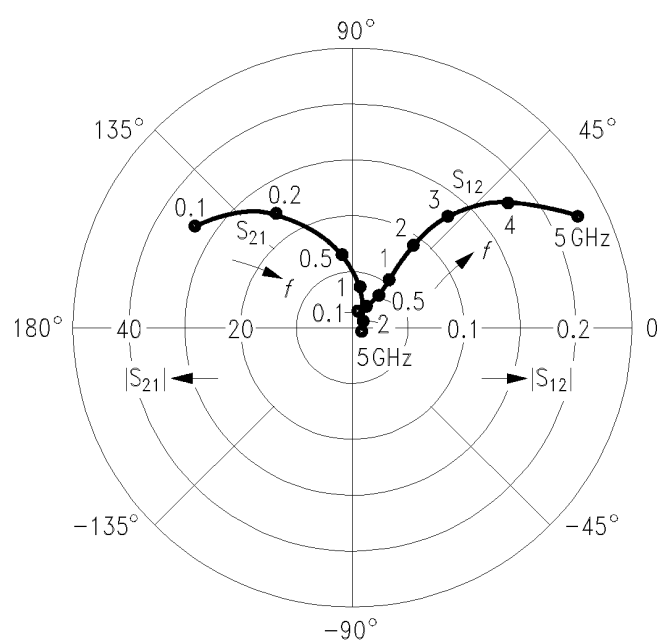

EHT07676

Common Emitter S Parameters (continued)

<i>f</i>	<i>S</i> <sub>11</sub>		<i>S</i> <sub>21</sub>		<i>S</i> <sub>12</sub>		<i>S</i> <sub>22</sub>		
	GHz	MAG	ANG	MAG	ANG	MAG	ANG	MAG	ANG
<i>I</i> <sub>C</sub> = 25 mA, <i>V</i> <sub>CE</sub> = 10 V, <i>Z</i> <sub>0</sub> = 50 Ω									
0.1	0.69	- 55	34.86	143	0.013	66	0.83	- 19	
0.2	0.59	- 94	24.49	121	0.020	55	0.66	- 27	
0.3	0.54	- 120	18.09	109	0.025	50	0.56	- 29	
0.4	0.51	- 135	14.03	101	0.029	50	0.51	- 28	
0.6	0.51	- 154	9.73	90	0.035	52	0.45	- 28	
0.8	0.50	- 167	7.33	82	0.042	54	0.43	- 29	
1.0	0.52	- 176	5.90	76	0.049	56	0.41	- 30	
1.2	0.51	175	4.96	70	0.057	57	0.40	- 32	
1.5	0.52	165	4.00	62	0.068	57	0.40	- 35	
1.8	0.53	158	3.34	54	0.080	56	0.39	- 40	
2.0	0.55	153	3.02	50	0.087	55	0.38	- 43	
2.5	0.57	143	2.47	38	0.108	53	0.36	- 52	
3.0	0.60	131	2.10	27	0.130	49	0.36	- 63	
3.5	0.62	122	1.85	16	0.152	46	0.35	- 75	
4.0	0.64	110	1.65	5	0.179	40	0.36	- 90	
4.5	0.67	101	1.48	- 6	0.200	34	0.35	- 105	
5.0	0.68	90	1.33	- 16	0.224	27	0.36	- 122	

*S*<sub>11</sub>, *S*<sub>22</sub> = *f* (*f*), *Z*-plane

*I*<sub>C</sub> = 25 mA, *V*<sub>CE</sub> = 10 V, *Z*<sub>0</sub> = 50 Ω

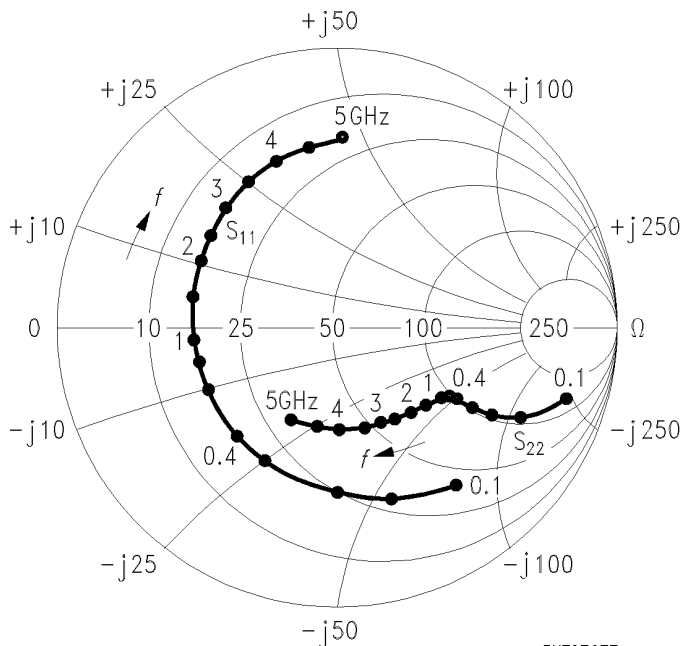

EHT07677

*S*<sub>12</sub>, *S*<sub>21</sub> = *f* (*f*)

*I*<sub>C</sub> = 25 mA, *V*<sub>CE</sub> = 10 V, *Z*<sub>0</sub> = 50 Ω

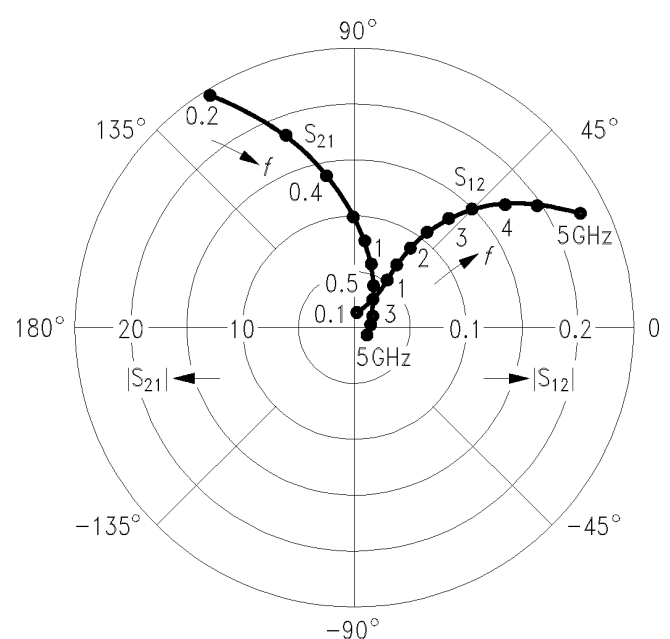

EHT07678



LittleDiode supplies new, hard to find or obsolete electronic components and semiconductors all over the world.

With over two million different components listed you are sure to find the part you need.

Feel free to visit us today at our online store:

[LittleDiode.com](http://LittleDiode.com)

Looking forward to providing you with the best possible service.