

# DATA SHEET

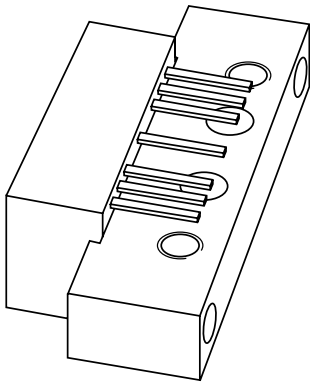

## **BGY888**

**860 MHz, 34 dB gain push-pull  
amplifier**

Product specification  
Supersedes data of 1999 Mar 30

2001 Oct 25

# 860 MHz, 34 dB gain push-pull amplifier

# BGY888

### FEATURES

- Excellent linearity
- Extremely low noise
- High gain
- Excellent return loss properties.

### APPLICATIONS

- Single module line extender in CATV systems operating over a frequency range of 40 to 860 MHz.

### DESCRIPTION

Hybrid high dynamic range amplifier module operating with a voltage supply of 24 V in a SOT115J package. The high gain module consists of two cascaded stages both in cascode configuration.

### PINNING SOT115J

PIN	DESCRIPTION
1	input
2, 3	common
5	+V <sub>B</sub>
7, 8	common
9	output

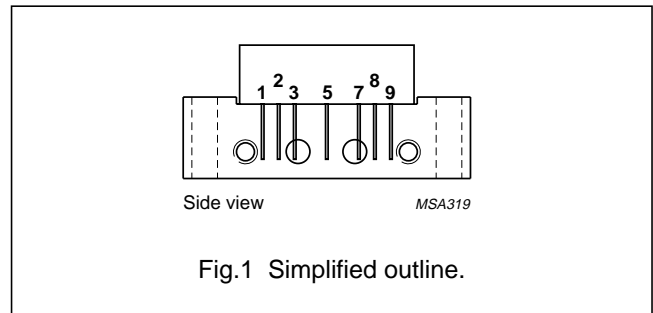

### QUICK REFERENCE DATA

SYMBOL	PARAMETER	CONDITIONS	MIN.	MAX.	UNIT
G <sub>p</sub>	power gain	f = 50 MHz	33.5	34.5	dB
		f = 860 MHz	34	–	dB
I <sub>tot</sub>	total current consumption (DC)	V <sub>B</sub> = 24 V	–	340	mA

### LIMITING VALUES

In accordance with the Absolute Maximum Rating System (IEC 60134).

SYMBOL	PARAMETER	MIN.	MAX.	UNIT
V <sub>i</sub>	RF input voltage	–	55	dBmV
T <sub>stg</sub>	storage temperature	–40	+100	°C
T <sub>mb</sub>	operating mounting base temperature	–20	+100	°C

## 860 MHz, 34 dB gain push-pull amplifier

BGY888

## CHARACTERISTICS

**Table 1** Bandwidth 40 to 860 MHz;  $V_B = 24$  V;  $T_{case} = 30$  °C;  $Z_S = Z_L = 75$   $\Omega$ 

SYMBOL	PARAMETER	CONDITIONS	MIN.	TYP.	MAX.	UNIT
G <sub>p</sub>	power gain	f = 50 MHz	33.5	34	34.5	dB
		f = 860 MHz	34	35	–	dB
SL	slope cable equivalent	f = 40 to 860 MHz	0.5	1.1	2.5	dB
FL	flatness of frequency response	f = 40 to 860 MHz	–	±0.2	±0.5	dB
S <sub>11</sub>	input return losses	f = 40 to 80 MHz	20	25	–	dB
		f = 80 to 160 MHz	18.5	28	–	dB
		f = 160 to 320 MHz	17	28	–	dB
		f = 320 to 640 MHz	15.5	21	–	dB
		f = 640 to 860 MHz	14	18.5	–	dB
S <sub>22</sub>	output return losses	f = 40 to 80 MHz	20	25.5	–	dB
		f = 80 to 160 MHz	18.5	28.5	–	dB
		f = 160 to 320 MHz	17	26.5	–	dB
		f = 320 to 640 MHz	15.5	20.5	–	dB
		f = 640 to 860 MHz	14	21	–	dB
S <sub>21</sub>	phase response	f = 50 MHz	135	–	225	deg
CTB	composite triple beat	49 channels flat; V <sub>o</sub> = 44 dBmV; measured at 859.25 MHz	–	–63.5	–60	dB
X <sub>mod</sub>	cross modulation	49 channels flat; V <sub>o</sub> = 44 dBmV; measured at 55.25 MHz	–	–63	–59	dB
CSO	composite second order distortion	49 channels flat; V <sub>o</sub> = 44 dBmV; measured at 860.5 MHz	–	–64	–55	dB
d <sub>2</sub>	second order distortion	note 1	–	–74	–65	dB
V <sub>o</sub>	output voltage	d <sub>im</sub> = –60 dB; note 2	58	60	–	dBmV
F	noise figure	f = 50 MHz	–	4	4.5	dB
		f = 550 MHz	–	–	5	dB
		f = 600 MHz	–	–	5	dB
		f = 650 MHz	–	–	5.5	dB
		f = 750 MHz	–	–	6	dB
		f = 860 MHz	–	5.5	7	dB
I <sub>tot</sub>	total current consumption (DC)	note 3	–	325	340	mA

## Notes

- f<sub>p</sub> = 55.25 MHz; V<sub>p</sub> = 44 dBmV;  
f<sub>q</sub> = 805.25 MHz; V<sub>q</sub> = 44 dBmV;  
measured at f<sub>p</sub> + f<sub>q</sub> = 860.5 MHz.
- Measured according to DIN45004B:  
f<sub>p</sub> = 851.25 MHz; V<sub>p</sub> = V<sub>o</sub>;  
f<sub>q</sub> = 858.25 MHz; V<sub>q</sub> = V<sub>o</sub> – 6 dB;  
f<sub>r</sub> = 860.25 MHz; V<sub>r</sub> = V<sub>o</sub> – 6 dB;  
measured at f<sub>p</sub> + f<sub>q</sub> – f<sub>r</sub> = 849.25 MHz.
- The module normally operates at V<sub>B</sub> = 24 V, but is able to withstand supply transients up to 30 V.

## 860 MHz, 34 dB gain push-pull amplifier

BGY888

**Table 2** Bandwidth 40 to 860 MHz;  $V_B = 24$  V;  $T_{case} = 30$  °C;  $Z_S = Z_L = 75$   $\Omega$ 

SYMBOL	PARAMETER	CONDITIONS	MIN.	TYP.	MAX.	UNIT
G <sub>p</sub>	power gain	f = 50 MHz	33.5	34	34.5	dB
		f = 860 MHz	34	35	–	dB
SL	slope cable equivalent	f = 40 to 860 MHz	0.5	1.1	2.5	dB
FL	flatness of frequency response	f = 40 to 860 MHz	–	±0.2	±0.5	dB
S <sub>11</sub>	input return losses	f = 40 to 80 MHz	20	25	–	dB
		f = 80 to 160 MHz	18.5	28	–	dB
		f = 160 to 320 MHz	17	28	–	dB
		f = 320 to 640 MHz	15.5	21	–	dB
		f = 640 to 860 MHz	14	18.5	–	dB
S <sub>22</sub>	output return losses	f = 40 to 80 MHz	20	25.5	–	dB
		f = 80 to 160 MHz	18.5	28.5	–	dB
		f = 160 to 320 MHz	17	26.5	–	dB
		f = 320 to 640 MHz	15.5	20.5	–	dB
		f = 640 to 860 MHz	14	21	–	dB
S <sub>21</sub>	phase response	f = 50 MHz	135	–	225	deg
CTB	composite triple beat	129 channels flat; V <sub>o</sub> = 44 dBmV; measured at 859.25 MHz	–	–47.5	–46	dB
X <sub>mod</sub>	cross modulation	129 channels flat; V <sub>o</sub> = 44 dBmV; measured at 55.25 MHz	–	–53.5	–50	dB
CSO	composite second order distortion	129 channels flat; V <sub>o</sub> = 44 dBmV; measured at 860.5 MHz	–	–56	–48	dB
d <sub>2</sub>	second order distortion	note 1	–	–74	–65	dB
V <sub>o</sub>	output voltage	d <sub>im</sub> = –60 dB; note 2	58	60	–	dBmV
F	noise figure	see Table 1	–	–	–	dB
I <sub>tot</sub>	total current consumption (DC)	note 3	–	325	340	mA

**Notes**

1.  $f_p = 55.25$  MHz;  $V_p = 44$  dBmV;  
 $f_q = 805.25$  MHz;  $V_q = 44$  dBmV;  
measured at  $f_p + f_q = 860.5$  MHz.
2. Measured according to DIN45004B:  
 $f_p = 851.25$  MHz;  $V_p = V_o$ ;  
 $f_q = 858.25$  MHz;  $V_q = V_o - 6$  dB;  
 $f_r = 860.25$  MHz;  $V_r = V_o - 6$  dB;  
measured at  $f_p + f_q - f_r = 849.25$  MHz.
3. The module normally operates at  $V_B = 24$  V, but is able to withstand supply transients up to 30 V.

## 860 MHz, 34 dB gain push-pull amplifier

BGY888

**Table 3** Bandwidth 40 to 750 MHz;  $V_B = 24$  V;  $T_{case} = 30$  °C;  $Z_S = Z_L = 75 \Omega$ 

SYMBOL	PARAMETER	CONDITIONS	MIN.	TYP.	MAX.	UNIT
G <sub>p</sub>	power gain	f = 50 MHz	33.5	34	34.5	dB
		f = 750 MHz	34	–	–	dB
SL	slope cable equivalent	f = 40 to 750 MHz	0.2	–	2.2	dB
FL	flatness of frequency response	f = 40 to 750 MHz	–	–	±0.45	dB
S <sub>11</sub>	input return losses	f = 40 to 80 MHz	20	25	–	dB
		f = 80 to 160 MHz	18.5	28	–	dB
		f = 160 to 320 MHz	17	28	–	dB
		f = 320 to 640 MHz	15.5	21	–	dB
		f = 640 to 750 MHz	14	18.5	–	dB
S <sub>22</sub>	output return losses	f = 40 to 80 MHz	20	25.5	–	dB
		f = 80 to 160 MHz	18.5	28.5	–	dB
		f = 160 to 320 MHz	17	26.5	–	dB
		f = 320 to 640 MHz	15.5	20.5	–	dB
		f = 640 to 750 MHz	14	21	–	dB
S <sub>21</sub>	phase response	f = 50 MHz	135	–	225	deg
CTB	composite triple beat	110 channels flat; V <sub>o</sub> = 44 dBmV; measured at 745.25 MHz	–	–52.5	–50	dB
X <sub>mod</sub>	cross modulation	110 channels flat; V <sub>o</sub> = 44 dBmV; measured at 55.25 MHz	–	–55.5	–51	dB
CSO	composite second order distortion	110 channels flat; V <sub>o</sub> = 44 dBmV; measured at 746.5 MHz	–	–61.5	–53	dB
d <sub>2</sub>	second order distortion	note 1	–	–	–65	dB
V <sub>o</sub>	output voltage	d <sub>im</sub> = –60 dB; note 2	59	–	–	dBmV
F	noise figure	see Table 1	–	–	–	dB
I <sub>tot</sub>	total current consumption (DC)	note 3	–	325	340	mA

**Notes**

1.  $f_p = 55.25$  MHz;  $V_p = 44$  dBmV;  
 $f_q = 691.25$  MHz;  $V_q = 44$  dBmV;  
measured at  $f_p + f_q = 746.5$  MHz.
2. Measured according to DIN45004B:  
 $f_p = 740.25$  MHz;  $V_p = V_o$ ;  
 $f_q = 747.25$  MHz;  $V_q = V_o - 6$  dB;  
 $f_r = 749.25$  MHz;  $V_r = V_o - 6$  dB;  
measured at  $f_p + f_q - f_r = 738.25$  MHz.
3. The module normally operates at  $V_B = 24$  V, but is able to withstand supply transients up to 30 V.

## 860 MHz, 34 dB gain push-pull amplifier

BGY888

**Table 4** Bandwidth 40 to 600 MHz;  $V_B = 24$  V;  $T_{case} = 30$  °C;  $Z_S = Z_L = 75 \Omega$ 

SYMBOL	PARAMETER	CONDITIONS	MIN.	TYP.	MAX.	UNIT
G <sub>p</sub>	power gain	f = 50 MHz	33.5	34	34.5	dB
		f = 600 MHz	34	–	–	dB
SL	slope cable equivalent	f = 40 to 600 MHz	0	–	2	dB
FL	flatness of frequency response	f = 40 to 600 MHz	–	–	±0.35	dB
S <sub>11</sub>	input return losses	f = 40 to 80 MHz	20	25	–	dB
		f = 80 to 160 MHz	18.5	28	–	dB
		f = 160 to 320 MHz	17	28	–	dB
		f = 320 to 600 MHz	16	21	–	dB
S <sub>22</sub>	output return losses	f = 40 to 80 MHz	20	25.5	–	dB
		f = 80 to 160 MHz	18.5	28.5	–	dB
		f = 160 to 320 MHz	17	26.5	–	dB
		f = 320 to 600 MHz	16	20.5	–	dB
S <sub>21</sub>	phase response	f = 50MHz	135	–	225	deg
CTB	composite triple beat	85 channels flat; V <sub>o</sub> = 44 dBmV; measured at 595.25 MHz	–	–56.5	–55	dB
X <sub>mod</sub>	cross modulation	85 channels flat; V <sub>o</sub> = 44 dBmV; measured at 55.25 MHz	–	–58	–54	dB
CSO	composite second order distortion	85 channels flat; V <sub>o</sub> = 44 dBmV; measured at 596.5 MHz	–	–69.5	–56	dB
d <sub>2</sub>	second order distortion	note 1	–	–	–68	dB
V <sub>o</sub>	output voltage	d <sub>im</sub> = –60 dB; note 2	61	–	–	dBmV
F	noise figure (DC)	see Table 1	–	–	–	dB
I <sub>tot</sub>	total current consumption	note 3	–	325	340	mA

**Notes**

1.  $f_p = 55.25$  MHz;  $V_p = 44$  dBmV;  
 $f_q = 541.25$  MHz;  $V_q = 44$  dBmV;  
measured at  $f_p + f_q = 596.5$  MHz.
2. Measured according to DIN45004B:  
 $f_p = 590.25$  MHz;  $V_p = V_o$ ;  
 $f_q = 597.25$  MHz;  $V_q = V_o - 6$  dB;  
 $f_r = 599.25$  MHz;  $V_r = V_o - 6$  dB;  
measured at  $f_p + f_q - f_r = 588.25$  MHz.
3. The module normally operates at  $V_B = 24$  V, but is able to withstand supply transients up to 30 V.

860 MHz, 34 dB gain push-pull amplifier

BGY888

PACKAGE OUTLINE

Rectangular single-ended package; aluminium flange; 2 vertical mounting holes; 2 x 6-32 UNC and 2 extra horizontal mounting holes; 7 gold-plated in-line leads

SOT115J

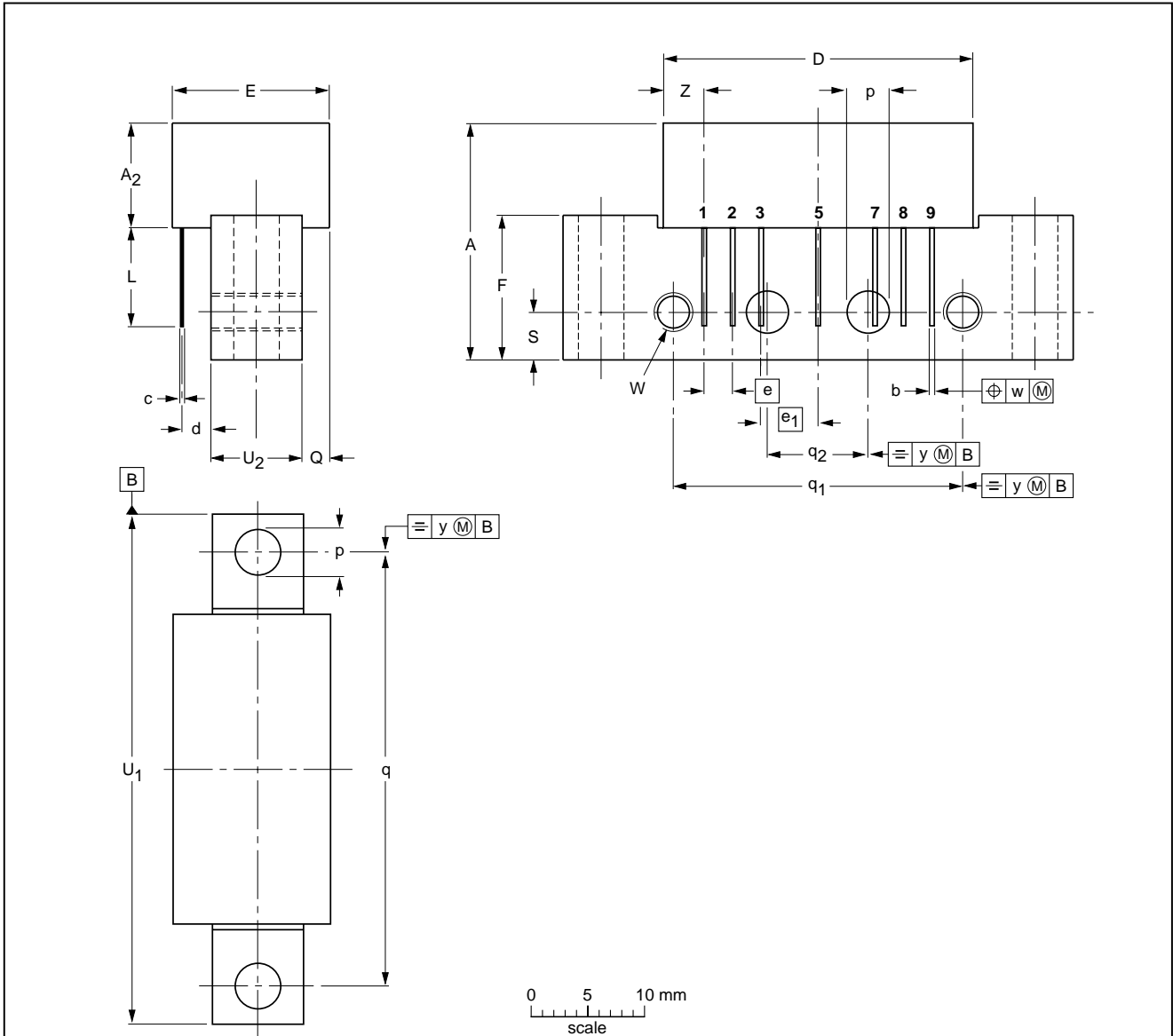

DIMENSIONS (mm are the original dimensions)

UNIT	A max.	A <sub>2</sub> max.	b	c	D max.	d max.	E max.	e	e <sub>1</sub>	F	L min.	p	Q max.	q	q <sub>1</sub>	q <sub>2</sub>	S	U <sub>1</sub> max.	U <sub>2</sub>	W	w	y	Z max.
mm	20.8	9.1	0.51 0.38	0.25	27.2	2.54	13.75	2.54	5.08	12.7	8.8	4.15 3.85	2.4	38.1	25.4	10.2	4.2	44.75	8	6-32 UNC	0.25	0.1	3.8

OUTLINE VERSION	REFERENCES				EUROPEAN PROJECTION	ISSUE DATE
	IEC	JEDEC	EIAJ			
SOT115J						99-02-06

## 860 MHz, 34 dB gain push-pull amplifier

BGY888

## DATA SHEET STATUS

DATA SHEET STATUS <sup>(1)</sup>	PRODUCT STATUS <sup>(2)</sup>	DEFINITIONS
Objective data	Development	This data sheet contains data from the objective specification for product development. Philips Semiconductors reserves the right to change the specification in any manner without notice.
Preliminary data	Qualification	This data sheet contains data from the preliminary specification. Supplementary data will be published at a later date. Philips Semiconductors reserves the right to change the specification without notice, in order to improve the design and supply the best possible product.
Product data	Production	This data sheet contains data from the product specification. Philips Semiconductors reserves the right to make changes at any time in order to improve the design, manufacturing and supply. Changes will be communicated according to the Customer Product/Process Change Notification (CPCN) procedure SNW-SQ-650A.

## Notes

1. Please consult the most recently issued data sheet before initiating or completing a design.
2. The product status of the device(s) described in this data sheet may have changed since this data sheet was published. The latest information is available on the Internet at URL <http://www.semiconductors.philips.com>.

## DEFINITIONS

**Short-form specification** — The data in a short-form specification is extracted from a full data sheet with the same type number and title. For detailed information see the relevant data sheet or data handbook.

**Limiting values definition** — Limiting values given are in accordance with the Absolute Maximum Rating System (IEC 60134). Stress above one or more of the limiting values may cause permanent damage to the device. These are stress ratings only and operation of the device at these or at any other conditions above those given in the Characteristics sections of the specification is not implied. Exposure to limiting values for extended periods may affect device reliability.

**Application information** — Applications that are described herein for any of these products are for illustrative purposes only. Philips Semiconductors make no representation or warranty that such applications will be suitable for the specified use without further testing or modification.

## DISCLAIMERS

**Life support applications** — These products are not designed for use in life support appliances, devices, or systems where malfunction of these products can reasonably be expected to result in personal injury. Philips Semiconductors customers using or selling these products for use in such applications do so at their own risk and agree to fully indemnify Philips Semiconductors for any damages resulting from such application.

**Right to make changes** — Philips Semiconductors reserves the right to make changes, without notice, in the products, including circuits, standard cells, and/or software, described or contained herein in order to improve design and/or performance. Philips Semiconductors assumes no responsibility or liability for the use of any of these products, conveys no licence or title under any patent, copyright, or mask work right to these products, and makes no representations or warranties that these products are free from patent, copyright, or mask work right infringement, unless otherwise specified.

860 MHz, 34 dB gain push-pull amplifier

BGY888

---

**NOTES**

860 MHz, 34 dB gain push-pull amplifier

BGY888

---

**NOTES**

860 MHz, 34 dB gain push-pull amplifier

BGY888

---

**NOTES**

# ***Philips Semiconductors – a worldwide company***

## **Contact information**

For additional information please visit <http://www.semiconductors.philips.com>. Fax: **+31 40 27 24825**

For sales offices addresses send e-mail to: [sales.addresses@www.semiconductors.philips.com](mailto:sales.addresses@www.semiconductors.philips.com).

© Koninklijke Philips Electronics N.V. 2001

SCA73

All rights are reserved. Reproduction in whole or in part is prohibited without the prior written consent of the copyright owner.

The information presented in this document does not form part of any quotation or contract, is believed to be accurate and reliable and may be changed without notice. No liability will be accepted by the publisher for any consequence of its use. Publication thereof does not convey nor imply any license under patent- or other industrial or intellectual property rights.

Printed in The Netherlands

613518/05/pp12

Date of release: 2001 Oct 25

Document order number: 9397 750 08823

*Let's make things better.*

**Philips  
Semiconductors**



**PHILIPS**



LittleDiode supplies new, hard to find or obsolete electronic components and semiconductors all over the world.

With over two million different components listed you are sure to find the part you need.

Feel free to visit us today at our online store:

**[LittleDiode.com](http://LittleDiode.com)**

Looking forward to providing you with the best possible service.