

Neu: Silizium-PIN-Fotodiode
New: Silicon PIN Photodiode

BP 104 S

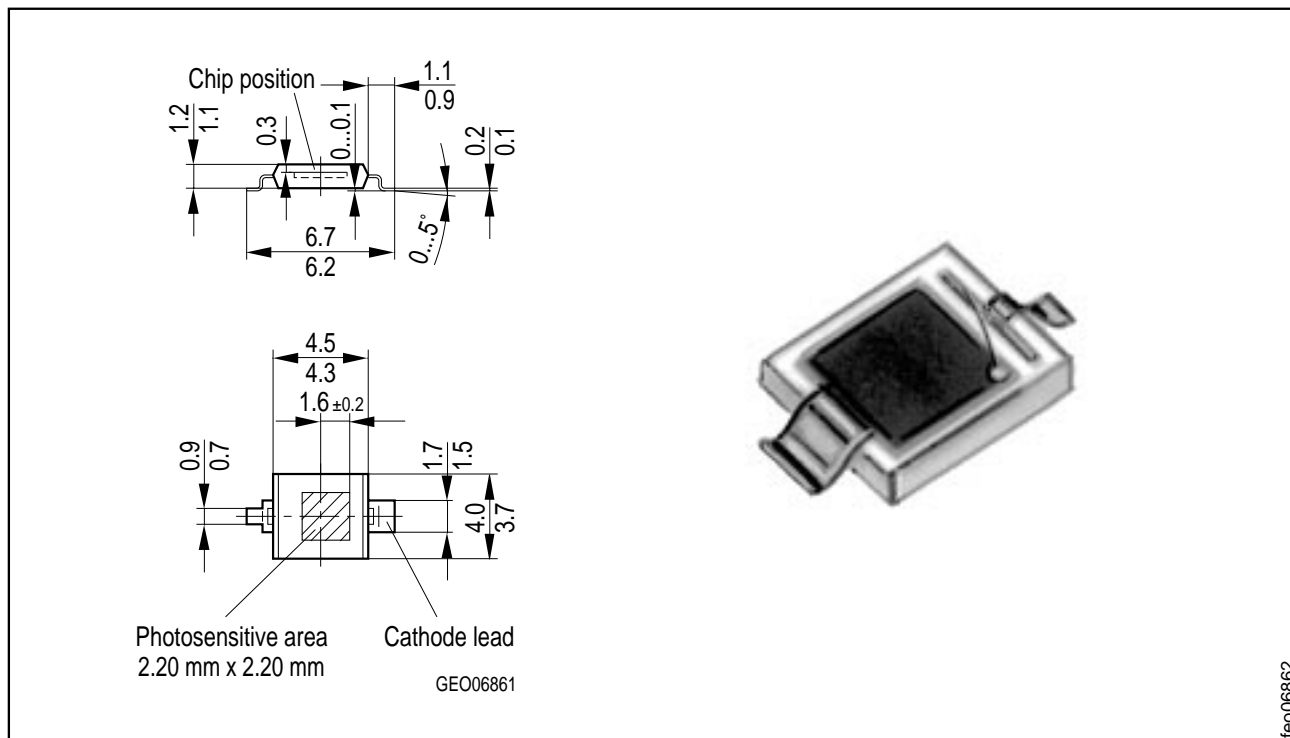

Maße in mm, wenn nicht anders angegeben/Dimensions in mm, unless otherwise specified.

Wesentliche Merkmale

- Speziell geeignet für Anwendungen im Bereich von 400 nm bis 1100 nm
- Kurze Schaltzeit (typ. 20 ns)
- geeignet für Vapor-Phase Löten und IR-Reflow-Löten
- SMT-fähig

Anwendungen

- Lichtschranken für Gleich- und Wechsellichtbetrieb
- IR-Fernsteuerungen
- Industrieelektronik
- "Messen/Steuern/Regeln"

Features

- Especially suitable for applications from 400 nm to 1100 nm
- Short switching time (typ. 20 ns)
- Suitable for vapor-phase and IR-reflow soldering
- Suitable for SMT

Applications

- Photointerrupters
- IR remote controls
- Industrial electronics
- For control and drive circuits

Typ Type	Bestellnummer Ordering Code
BP 104 S	Q62702-P1605

Grenzwerte Maximum Ratings

Bezeichnung Description	Symbol Symbol	Wert Value	Einheit Unit
Betriebs- und Lagertemperatur Operating and storage temperature range	$T_{op}; T_{stg}$	- 40 ... + 85	°C
Sperrspannung Reverse voltage	V_R	20	V
Verlustleistung, $T_A = 25\text{ °C}$ Total power dissipation	P_{tot}	150	mW

Kennwerte ($T_A = 25\text{ °C}$, Normlicht A, $T = 2856\text{ K}$) Characteristics ($T_A = 25\text{ °C}$, standard light A, $T = 2856\text{ K}$)

Bezeichnung Description	Symbol Symbol	Wert Value	Einheit Unit
Fotoempfindlichkeit $V_R = 5\text{ V}$ Spectral sensitivity	S	55 (≥ 40)	nA/lx
Wellenlänge der max. Fotoempfindlichkeit Wavelength of max. sensitivity	$\lambda_{S\max}$	850	nm
Spektraler Bereich der Fotoempfindlichkeit $S = 10\%$ von S_{\max} Spectral range of sensitivity $S = 10\%$ of S_{\max}	λ	400 ... 1100	nm
Bestrahlungsempfindliche Fläche Radiant sensitive area	A	4.84	mm ²
Abmessung der bestrahlungsempfindlichen Fläche Dimensions of radiant sensitive area	$L \times B$ $L \times W$	2.20 × 2.20	mm × mm
Abstand Chipoberfläche zu Gehäuseoberfläche Distance chip front to case surface	H	0.3	mm
Halbwinkel Half angle	φ	± 60	Grad deg.
Dunkelstrom, $V_R = 10\text{ V}$ Dark current	I_R	2 (≤ 30)	nA
Spektrale Fotoempfindlichkeit, $\lambda = 850\text{ nm}$ Spectral sensitivity	S_λ	0.62	A/W
Quantenausbeute, $\lambda = 850\text{ nm}$ Quantum yield	η	0.90	<u>Electrons</u> Photon

Kennwerte ($T_A = 25\text{ °C}$, Normlicht A, $T = 2856\text{ K}$)

Characteristics ($T_A = 25\text{ °C}$, standard light A, $T = 2856\text{ K}$) (cont'd)

Bezeichnung Description	Symbol Symbol	Wert Value	Einheit Unit
Leerlaufspannung, $E_V = 1000\text{ lx}$ Open-circuit voltage	V_O	360 (≥ 280)	mV
Kurzschlußstrom, $E_V = 1000\text{ lx}$ Short-circuit current	I_{SC}	50	μA
Anstiegs- und Abfallzeit des Fotostromes Rise and fall time of the photocurrent $R_L = 50\ \Omega$; $V_R = 5\text{ V}$; $\lambda = 850\text{ nm}$; $I_p = 800\ \mu\text{A}$	t_r, t_f	20	ns
Durchlaßspannung, $I_F = 100\text{ mA}$, $E = 0$ Forward voltage	V_F	1.3	V
Kapazität, $V_R = 0\text{ V}$, $f = 1\text{ MHz}$, $E = 0$ Capacitance	C_0	48	pF
Temperaturkoeffizient von V_O Temperature coefficient of V_O	TK_V	- 2.6	mV/K
Temperaturkoeffizient von I_{SC} Temperature coefficient of I_{SC}	TK_I	0.18	%/K
Rauschäquivalente Strahlungsleistung Noise equivalent power $V_R = 10\text{ V}$, $\lambda = 850\text{ nm}$	NEP	3.6×10^{-14}	$\frac{\text{W}}{\sqrt{\text{Hz}}}$
Nachweisgrenze, $V_R = 10\text{ V}$, $\lambda = 850\text{ nm}$ Detection limit	D^*	6.1×10^{12}	$\frac{\text{cm} \cdot \sqrt{\text{Hz}}}{\text{W}}$

Relative spectral sensitivity

$$S_{rel} = f(\lambda)$$

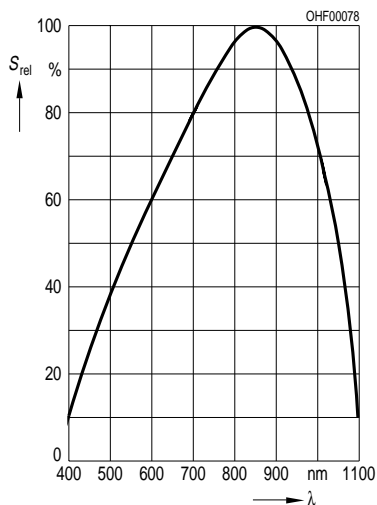

Photocurrent $I_P = f(E_V), V_R = 5 V$

$$\text{Open-circuit voltage } V_O = f(E_V)$$

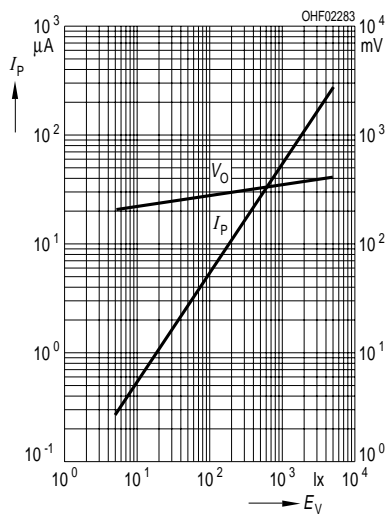

Total power dissipation $P_{tot} = f(T_A)$

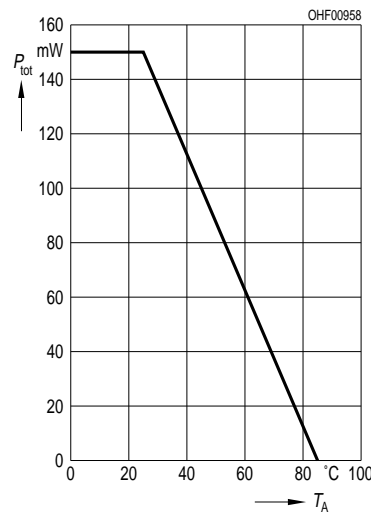

Dark current

$$I_R = f(V_R), E = 0$$

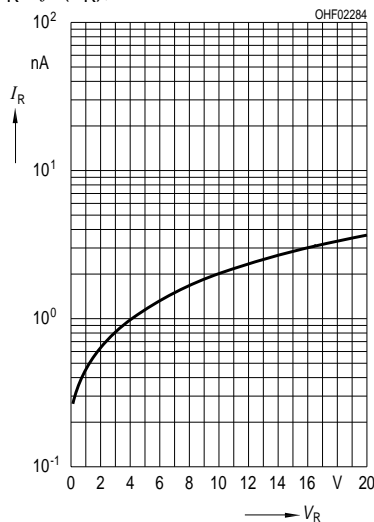

Capacitance

$$C = f(V_R), f = 1 \text{ MHz}, E = 0$$

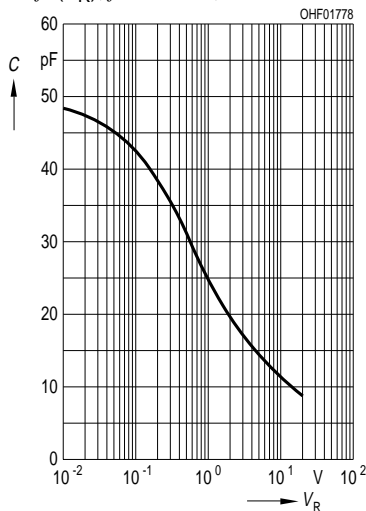

Dark current

$$I_R = f(T_A), V_R = 10 V, E = 0$$

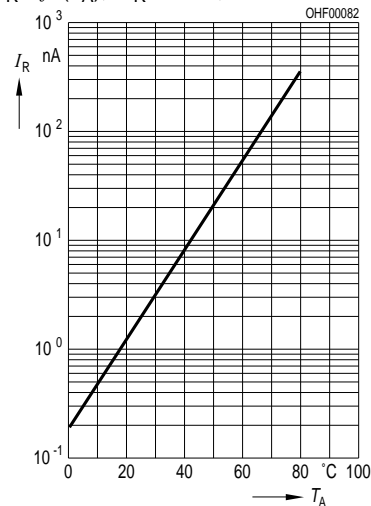

Directional characteristics $S_{rel} = f(\phi)$

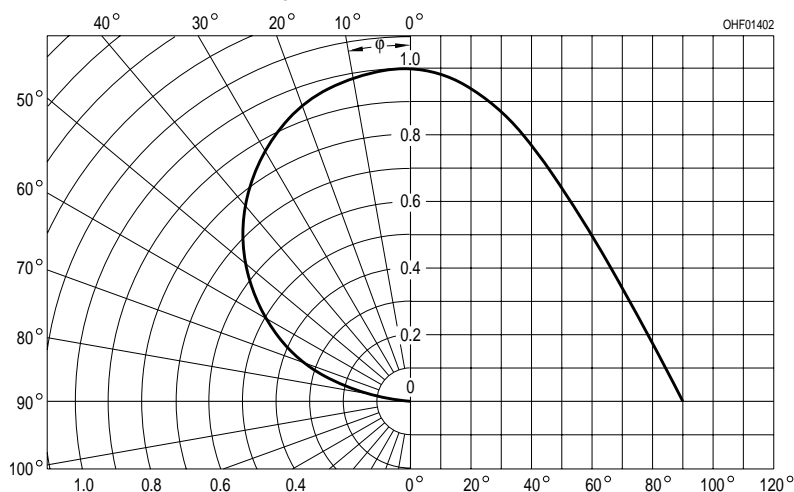



LittleDiode supplies new, hard to find or obsolete electronic components and semiconductors all over the world.

With over two million different components listed you are sure to find the part you need.

Feel free to visit us today at our online store:

LittleDiode.com

Looking forward to providing you with the best possible service.