

IGBT Transistor

BSP 280

Preliminary Data

- V_{CE} 1000 V
- I_C 2.5 A
- N channel
- MOS input (voltage-controlled)
- High switch speed
- Very low tail current
- Latch-up free
- Suitable freewheeling diode BAX 280

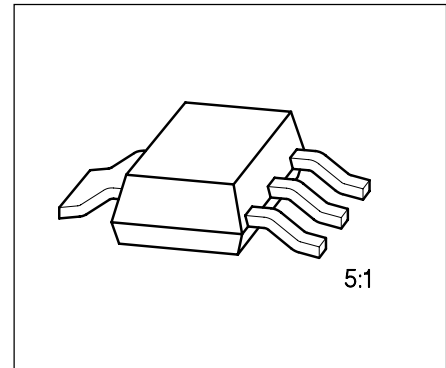

Type	Ordering Code	Tape and Reel Information	Pin Configuration				Marking	Package
			1	2	3	4		
BSP 280	Q67000-S279	E6327: 1000 pcs/reel	G	C	E	C	BSP 280	SOT-223

Maximum Ratings

Parameter	Symbol	Values	Unit
Continuous collector current	I_C	2.5 1.5	A
Soldering point, $T_S = 25\text{ °C}$			
$T_S = 80\text{ °C}$			
Continuous collector current ambient, $T_A = 80\text{ °C}$	I_C	0.5	
Pulsed collector current	$I_{C\text{ puls}}$	3.0	
Soldering point, $T_S = 80\text{ °C}$			
Collector-emitter voltage	V_{CE}	1000	V
Gate-emitter voltage	V_{GE}	± 20	
Power dissipation	P_{tot}	10 1.8	W
Soldering point, $T_S = 80\text{ °C}$			
Ambient $T_A = 25\text{ °C}$			
Operating and storage temperature range	T_j, T_{stg}	- 40 ... + 150	°C
Thermal resistance ¹⁾	chip-ambient R_{thJA} chip-soldering point R_{thJS}	70 6	K/W
DIN humidity category, DIN 40 040	–	E	–
IEC climatic category, DIN IEC 68-1	–	40/150/56	

IGBT = Insulated Gate Bipolar Transistor

¹⁾ Transistor on epoxy pcb 40 mm × 40 mm × 1.5 mm with 6 cm² copper area for drain connection.

Electrical Characteristics

at $T_j = 25\text{ °C}$, unless otherwise specified.

Parameter	Symbol	Values			Unit
		min.	typ.	max.	

Static Characteristics

Collector-emitter breakdown voltage $V_{GE} = 0, I_C = 0.1\text{ mA}$	$V_{(BR)CES}$	1000	–	–	V
Gate threshold voltage $V_{GE} = V_{CE}, I_C = 0.1\text{ mA}$	$V_{GE(th)}$	4.5	5.5	6.5	
Collector-emitter saturation voltage $V_{GE} = 15\text{ V}, I_C = 0.5\text{ A}$ $T_j = 25\text{ °C}$ $T_j = 125\text{ °C}$ $T_j = 150\text{ °C}$	$V_{CE(sat)}$	–	1.8	–	
$V_{GE} = 15\text{ V}, I_C = 1.5\text{ A}$ $T_j = 25\text{ °C}$ $T_j = 125\text{ °C}$ $T_j = 150\text{ °C}$		–	2.1	–	
		–	2.2	3.0	
		–	2.8	3.3	
		–	3.8	4.3	
		–	4.0	4.5	
Zero gate voltage collector current $V_{CE} = 1000\text{ V}, V_{GE} = 0$ $T_j = 25\text{ °C}$ $T_j = 125\text{ °C}$	I_{CES}	–	1	25	μA
		–	–	100	
Gate-emitter leakage current $V_{GE} = 20\text{ V}, V_{CE} = 0$	I_{GES}	–	0.1	100	nA

Dynamic Characteristics

Forward transconductance $V_{CE} = 20\text{ V}, I_C = 1.5\text{ A}$	g_{fs}	–	0.6	–	S
Input capacitance $V_{CE} = 0, V_{GE} = 25\text{ V}, f = 1\text{ MHz}$	C_{iss}	–	225	–	pF
Output capacitance $V_{CE} = 0, V_{GE} = 25\text{ V}, f = 1\text{ MHz}$	C_{oss}	–	25	–	
Reverse transfer capacitance $V_{CE} = 0, V_{GE} = 25\text{ V}, f = 1\text{ MHz}$	C_{rss}	–	13	–	
Turn-on delay time $V_{CC} = 600\text{ V}, V_{GE} = 15\text{ V}, R_{G(on)} = 25\text{ }\Omega, I_C = 1.5\text{ A}$	$t_{d(on)}$	–	20	–	ns
Rise time $V_{CC} = 600\text{ V}, V_{GE} = 15\text{ V}, R_{G(on)} = 25\text{ }\Omega, I_C = 1.5\text{ A}$	t_r	–	15	–	

Electrical Characteristics (cont'd)

at $T_j = 25\text{ }^\circ\text{C}$, unless otherwise specified.

Parameter	Symbol	Values			Unit
		min.	typ.	max.	
Turn-on losses $V_{CC} = 600\text{ V}$, $V_{GE} = 15\text{ V}$, $R_{G(off)} = 25\text{ }\Omega$, $I_C = 1.5\text{ A}$	E_{on}	–	0.3	–	mWs
Turn-off delay time $V_{CC} = 600\text{ V}$, $V_{GE} = 15\text{ V}$, $R_{G(off)} = 25\text{ }\Omega$, $I_C = 1.5\text{ A}$	$t_{d(off)}$	–	120	–	ns
Fall time $V_{CC} = 600\text{ V}$, $V_{GE} = 15\text{ V}$, $R_{G(off)} = 25\text{ }\Omega$, $I_C = 1.5\text{ A}$	t_f	–	20	–	
Total turn-off losses $V_{CC} = 600\text{ V}$, $V_{GE} = 15\text{ V}$, $R_{G(off)} = 25\text{ }\Omega$, $I_C = 1.5\text{ A}$	E_{off}	–	0.2	–	mWs

Package Outline

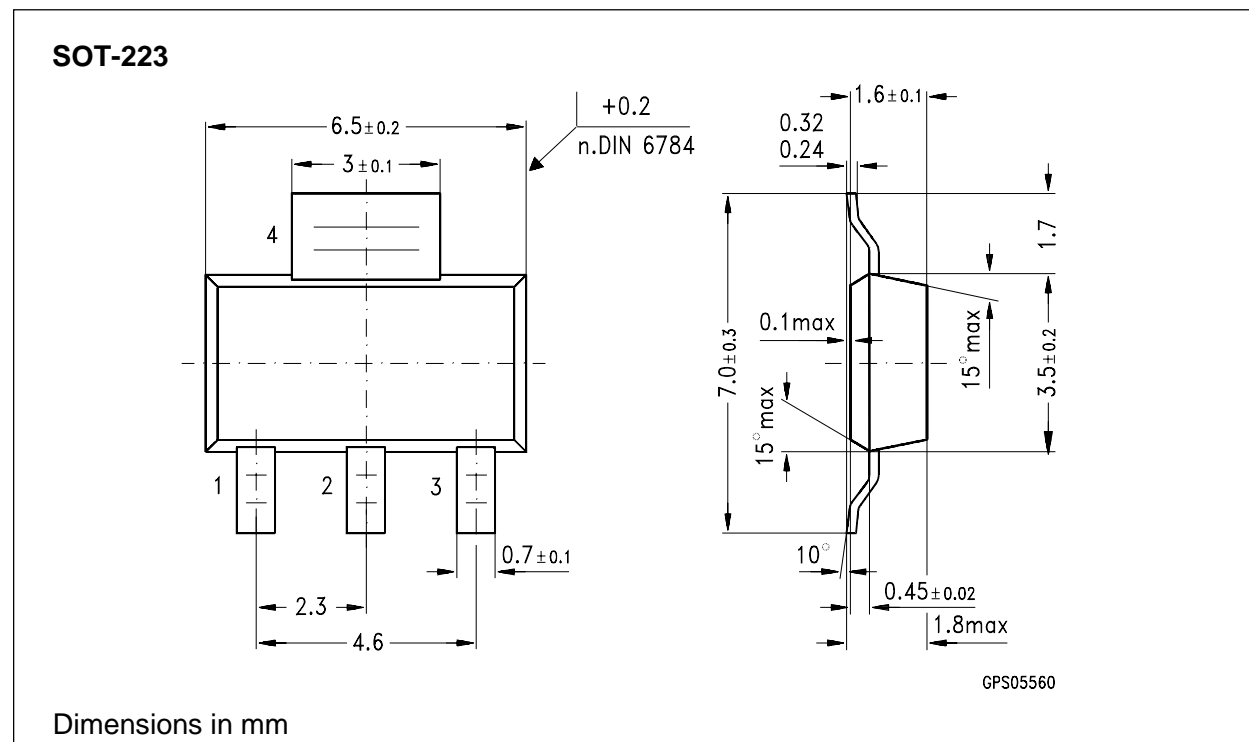

Characteristics
at $T_j = 25\text{ }^\circ\text{C}$, unless otherwise specified.

Typ. output characteristics $I_C = f(V_{CE})$
parameter: $t_p = 80\text{ }\mu\text{s}$

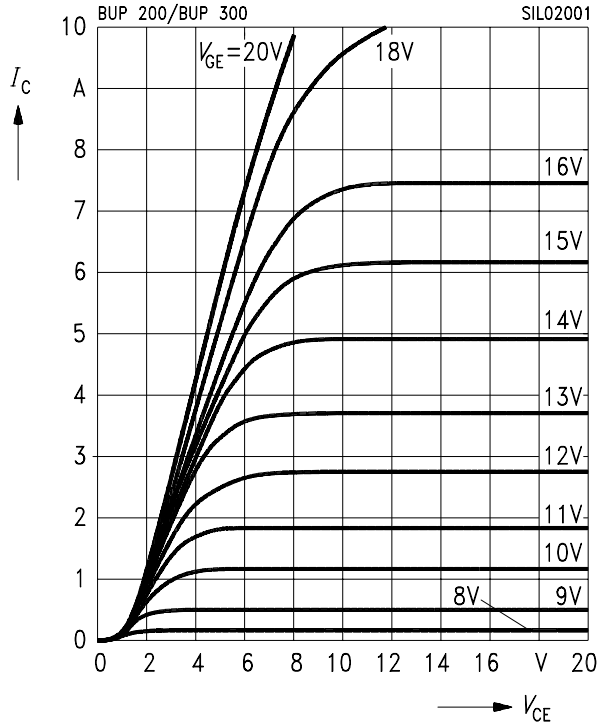

Typ. transfer characteristics $I_C = f(V_{GE})$
parameter: $t_p = 80\text{ }\mu\text{s}$, $V_{CE} = 20\text{ V}$

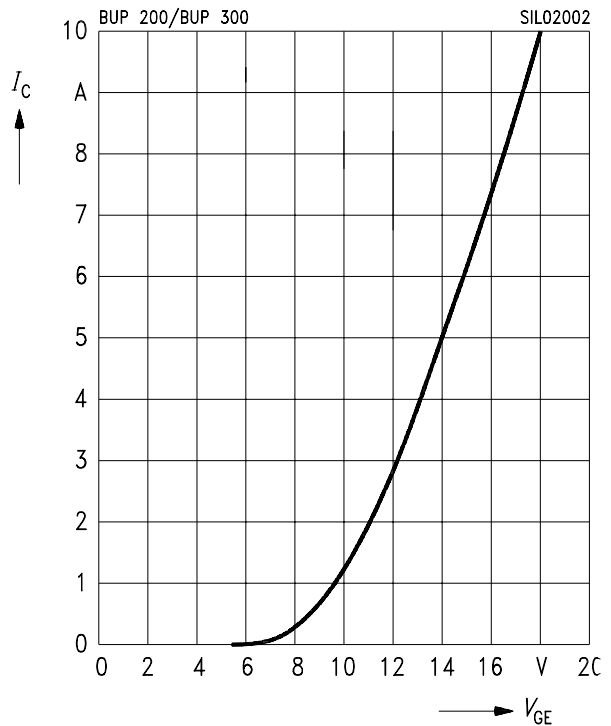

Typ. capacitances $C = f(V_{CE})$
parameter: $V_{GE} = 0\text{ V}$, $f = 1\text{ MHz}$

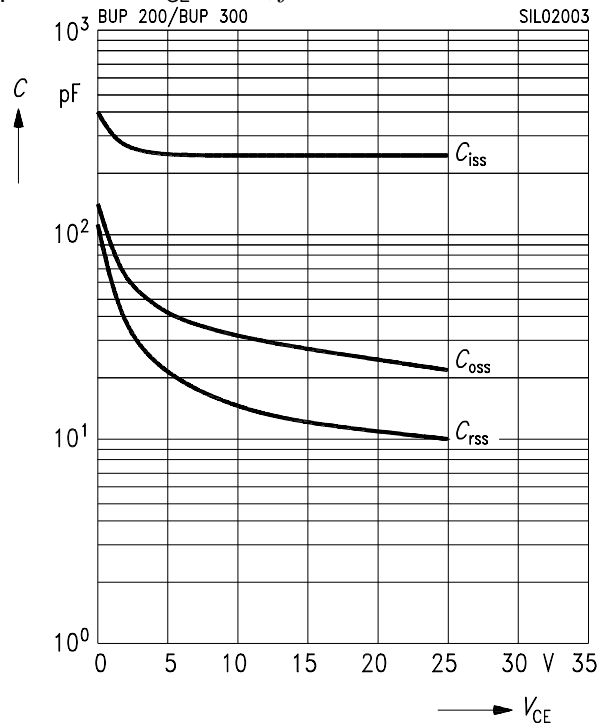

Typ. saturation characteristics
 $V_{CE(sat)} = f(V_{GE})$; parameter: $T_j = 25\text{ }^\circ\text{C}$

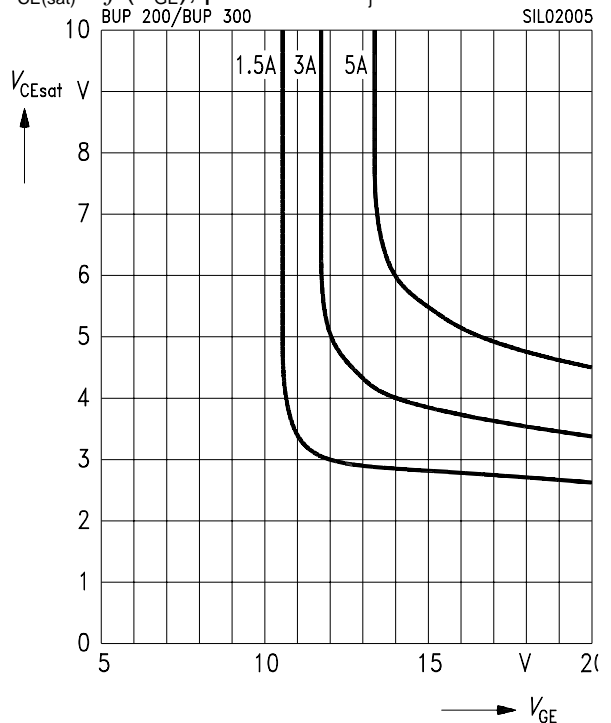

Typ. saturation characteristic

$V_{CE(sat)} = f(V_{GE})$; parameter: $T_j = 125\text{ °C}$

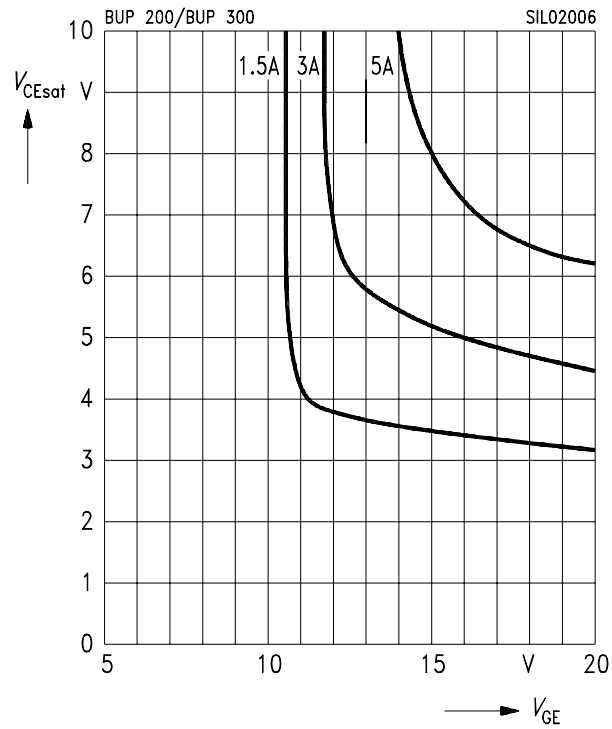

Typ. gate charge $V_{GE} = f(Q_{Gate})$

parameter: $I_{C plus} = 1\text{ A}$

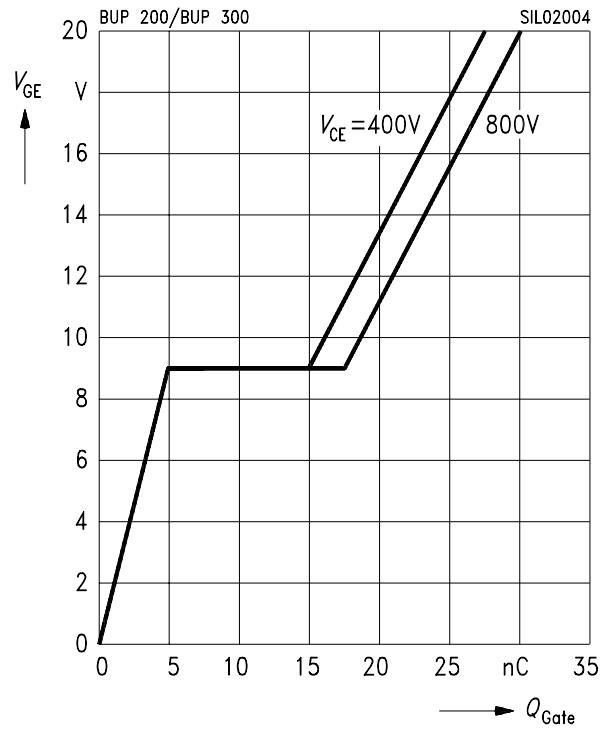



LittleDiode supplies new, hard to find or obsolete electronic components and semiconductors all over the world.

With over two million different components listed you are sure to find the part you need.

Feel free to visit us today at our online store:

LittleDiode.com

Looking forward to providing you with the best possible service.