

DATA SHEET

BSR56; BSR57; BSR58 N-channel FETs

Product specification
File under Discrete Semiconductors, SC07

April 1991

N-channel FETs

BSR56; BSR57; BSR58

DESCRIPTION

Symmetrical silicon n-channel depletion type junction field-effect transistors in a plastic microminiature envelope intended for application in thick and thin-film circuits. The transistors are intended for low-power, chopper or switching applications in industrial service.

PINNING

- 1 = drain
- 2 = source
- 3 = gate

Note

1. Drain and source are interchangeable.

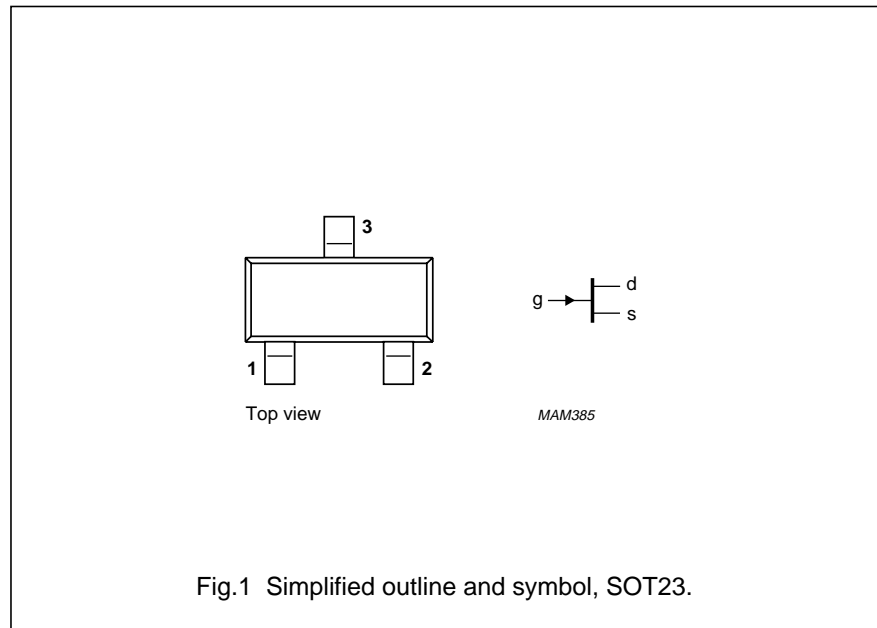

Marking code

- BSR56 = M4P
- BSR57 = M5P
- BSR58 = M6P

QUICK REFERENCE DATA

		BSR56	BSR57	BSR58		
Drain-source voltage	$\pm V_{DS}$	max. 40	40	40 V		
Total power dissipation up to $T_{amb} = 40\text{ }^\circ\text{C}$	P_{tot}	max. 250	250	250 mW		
Drain current $V_{DS} = 15\text{ V}; V_{GS} = 0$	I_{DSS}	>	50	20		
		<	—	100		
Gate-source cut-off voltage $V_{DS} = 15\text{ V}; I_D = 0.5\text{ nA}$	$-V_{(P)GS}$	>	4	2		
		<	10	6		
Drain-source resistance (on) at $f = 1\text{ kHz}$ $I_D = 0; V_{GS} = 0$	$r_{ds\ on}$	<	25	40		
					60 Ω	
Feedback capacitance at $f = 1\text{ MHz}$ $-V_{GS} = 10\text{ V}; V_{DS} = 0$	C_{rs}	<	5	5		
					5 pF	
Turn-off time $V_{DD} = 10\text{ V}; V_{GS} = 0$	t_{off}	$I_D = 20\text{ mA}; -V_{GSM} = 10\text{ V}$	<	25	—	
		$I_D = 10\text{ mA}; -V_{GSM} = 6\text{ V}$	<	—	50	— ns
		$I_D = 5\text{ mA}; -V_{GSM} = 4\text{ V}$	<	—	—	100 ns
			<	—	—	—

N-channel FETs

BSR56; BSR57; BSR58

RATINGS

Limiting values in accordance with the Absolute Maximum System (IEC 134)

Drain-source voltage	$\pm V_{DS}$	max.	40 V
Drain-gate voltage	V_{DGO}	max.	40 V
Gate-source voltage	$-V_{GSO}$	max.	40 V
Forward gate current	I_{GF}	max.	50 mA
Total power dissipation up to $T_{amb} = 40\text{ °C}$ (note 1)	P_{tot}	max.	250 mW
Storage temperature range	T_{stg}		-65 to +150 °C
Junction temperature	T_j	max.	150 °C

THERMAL RESISTANCE

From junction to ambient (note 1)	$R_{th\ j-a}$	=	430 K/W
-----------------------------------	---------------	---	---------

Notes

1. Mounted on a ceramic substrate of 8 mm × 10 mm × 0.7 mm.

CHARACTERISTICS $T_j = 25\text{ °C}$ unless otherwise specified

Gate-source cut-off current

$V_{DS} = 0\text{ V}; -V_{GS} = 20\text{ V}$	$-I_{GSS}$	max.	1.0 nA
--	------------	------	--------

Drain cut-off current

$V_{DS} = 15\text{ V}; -V_{GS} = 10\text{ V}$	I_{DSX}	max.	1.0 nA
---	-----------	------	--------

		BSR56	BSR57	BSR58
Drain current				
$V_{DS} = 15\text{ V}; V_{GS} = 0$	I_{DSS}	50	20	8 mA
		-	100	80 mA
Gate-source breakdown voltage				
$-I_G = 1\text{ }\mu\text{A}; V_{DS} = 0$	$-V_{(BR)GSS}$	40	40	40 V
Gate-source cut-off voltage				
$I_D = 0,5\text{ nA}; V_{DS} = 15\text{ V}$	$-V_{(P)GS}$	4	2	0.8 V
		10	6	4 V
Drain-source voltage (on)				
$I_D = 20\text{ mA}; V_{GS} = 0$	V_{DSon}	750	-	- mV
$I_D = 10\text{ mA}; V_{GS} = 0$	V_{DSon}	-	500	- mV
$I_D = 5\text{ mA}; V_{GS} = 0$	V_{DSon}	-	-	400 mV
Drain-source resistance (on) at $f = 1\text{ kHz}$				
$I_D = 0; V_{GS} = 0; T_a = 25\text{ °C}$	$r_{ds\ on}$	25	40	60 Ω
Feedback capacitance at $f = 1\text{ MHz}$				
$-V_{GS} = 10\text{ V}; V_{DS} = 0$	C_{rss}	5	5	5 pF

N-channel FETs

BSR56; BSR57; BSR58

Switching times

$V_{DD} = 10\text{ V}$; $V_{GS} = 0$
 Conditions I_D and $-V_{GSM}$

Delay time

Rise time

Turn-off time

		BSR56	BSR57	BSR58
I_D	=	20	10	5 mA
$-V_{GSM}$	=	10	6	4 V
Delay time	t_d	< 6	< 6	< 10 ns
Rise time	t_r	< 3	< 4	< 10 ns
Turn-off time	t_{off}	< 25	< 50	< 100 ns

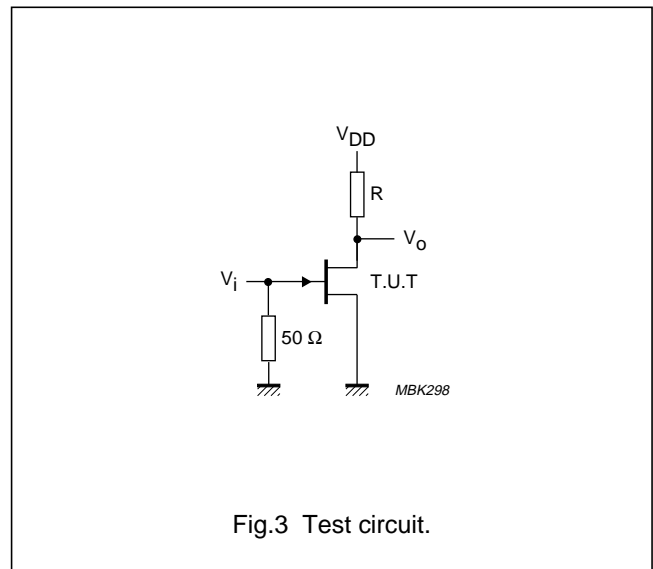
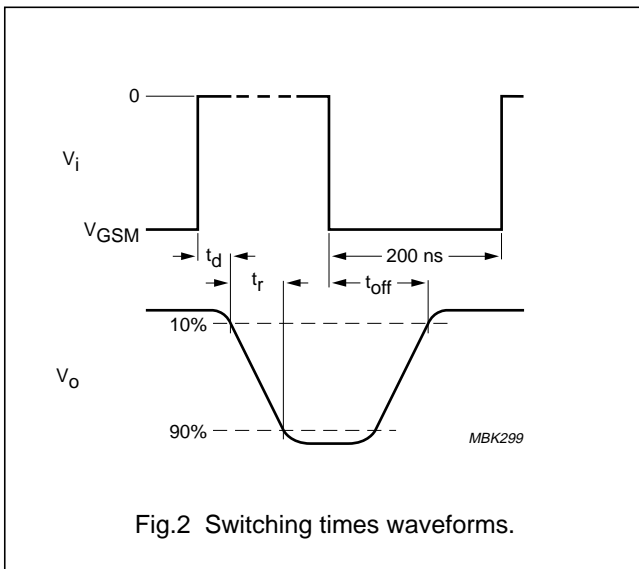

BSR56; $R = 464\ \Omega$

BSR57; $R = 953\ \Omega$

BSR58; $R = 1910\ \Omega$

Pulse generator

$t_r = t_f \leq 1\text{ ns}$

$\delta = 0.02$

$Z_o = 50\ \Omega$

Oscilloscope

$t_r \leq 0.75\text{ ns}$

$R_i \geq 1\text{ M}\Omega$

$C_i \leq 2.5\text{ pF}$

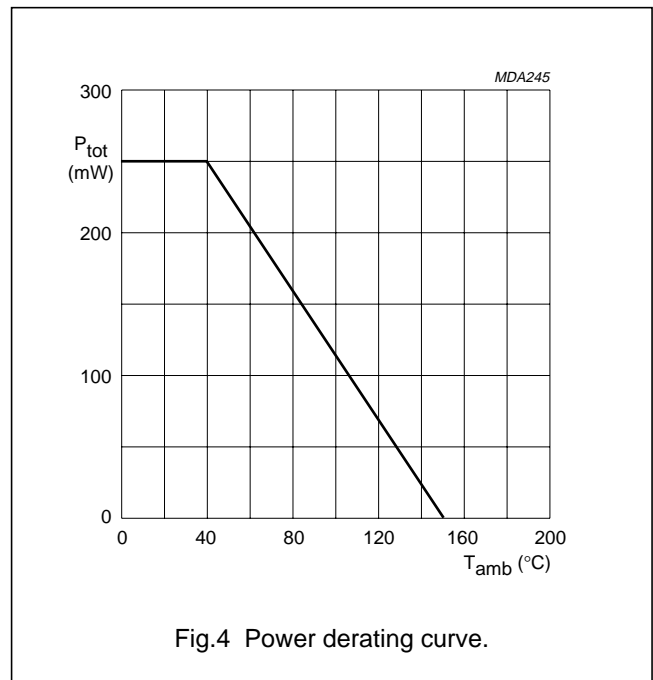

N-channel FETs

BSR56; BSR57; BSR58

PACKAGE OUTLINE

Plastic surface mounted package; 3 leads

SOT23

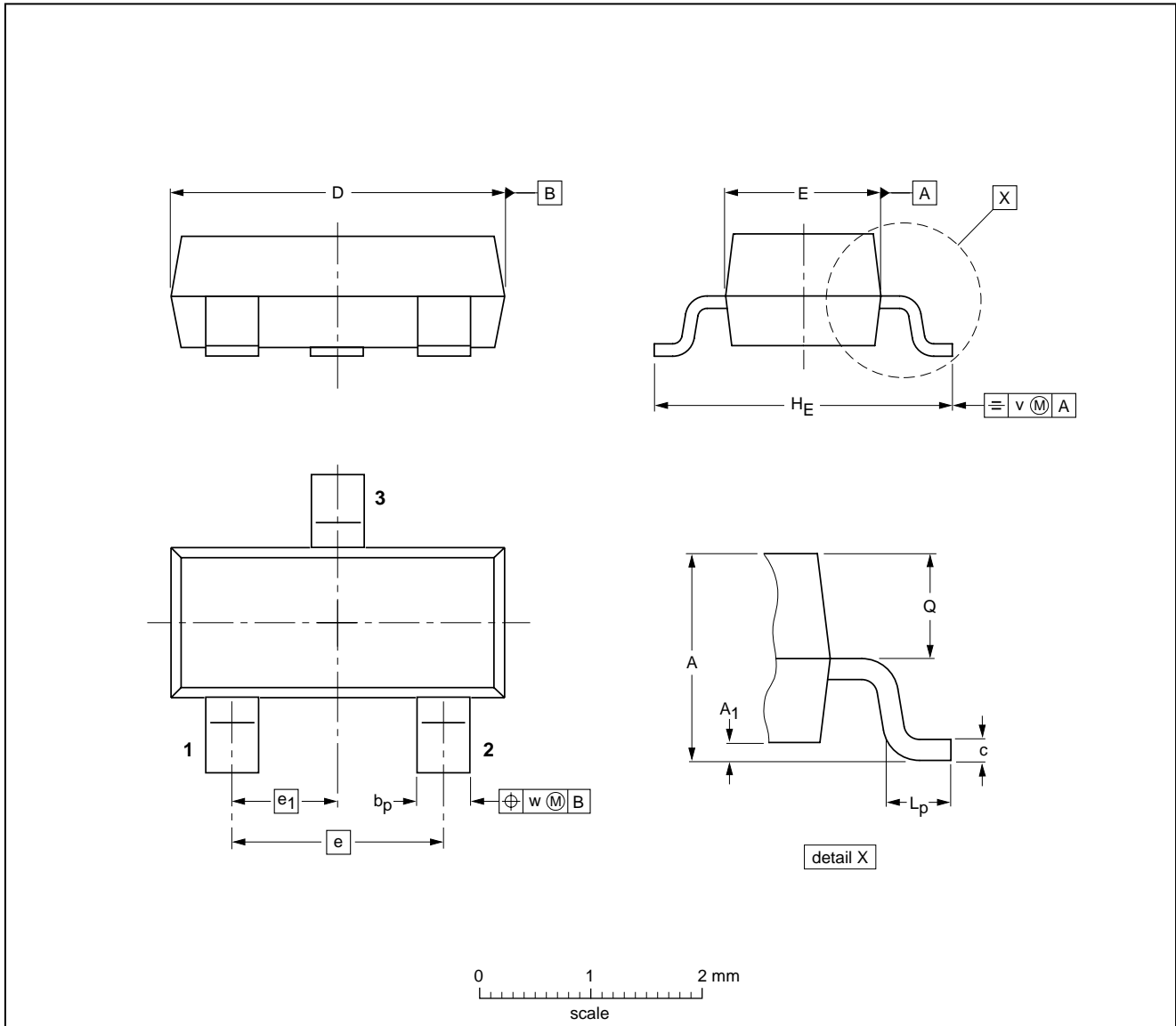

DIMENSIONS (mm are the original dimensions)

UNIT	A	A ₁ max.	b _p	c	D	E	e	e ₁	H _E	L _p	Q	v	w
mm	1.1 0.9	0.1	0.48 0.38	0.15 0.09	3.0 2.8	1.4 1.2	1.9	0.95	2.5 2.1	0.45 0.15	0.55 0.45	0.2	0.1

OUTLINE VERSION	REFERENCES				EUROPEAN PROJECTION	ISSUE DATE
	IEC	JEDEC	EIAJ			
SOT23						97-02-28

N-channel FETs

BSR56; BSR57; BSR58

DEFINITIONS

Data sheet status	
Objective specification	This data sheet contains target or goal specifications for product development.
Preliminary specification	This data sheet contains preliminary data; supplementary data may be published later.
Product specification	This data sheet contains final product specifications.
Short-form specification	The data in this specification is extracted from a full data sheet with the same type number and title. For detailed information see the relevant data sheet or data handbook.
Limiting values	
Limiting values given are in accordance with the Absolute Maximum Rating System (IEC 134). Stress above one or more of the limiting values may cause permanent damage to the device. These are stress ratings only and operation of the device at these or at any other conditions above those given in the Characteristics sections of the specification is not implied. Exposure to limiting values for extended periods may affect device reliability.	
Application information	
Where application information is given, it is advisory and does not form part of the specification.	

LIFE SUPPORT APPLICATIONS

These products are not designed for use in life support appliances, devices, or systems where malfunction of these products can reasonably be expected to result in personal injury. Philips customers using or selling these products for use in such applications do so at their own risk and agree to fully indemnify Philips for any damages resulting from such improper use or sale.



LittleDiode supplies new, hard to find or obsolete electronic components and semiconductors all over the world.

With over two million different components listed you are sure to find the part you need.

Feel free to visit us today at our online store:

LittleDiode.com

Looking forward to providing you with the best possible service.