

SIPMOS[®] Small-Signal Transistor

- N channel
- Depletion mode
- High dynamic resistance

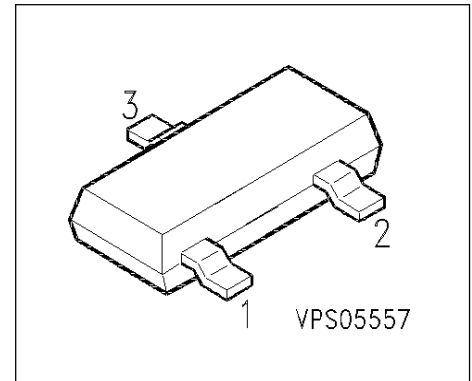

Pin 1	Pin 2	Pin 3
G	S	D

Type	V_{DS}	I_D	$R_{DS(on)}$	Package	Ordering Code
BSS 159	50 V	0.16 A	8 Ω	SOT-23	Q67050-T6

Maximum Ratings

Parameter	Symbol	Values	Unit
Drain source voltage	V_{DS}	50	V
Drain-gate voltage	V_{DGR}	50	
$R_{GS} = 20 \text{ k}\Omega$			
Gate source voltage	V_{GS}	± 14	
Gate-source peak voltage, aperiodic	V_{gs}	± 20	
Continuous drain current	I_D	0.16	A
$T_A = 25 \text{ }^\circ\text{C}$			
DC drain current, pulsed	I_{Dpuls}	0.48	
$T_A = 25 \text{ }^\circ\text{C}$			
Power dissipation	P_{tot}	0.36	W
$T_A = 25 \text{ }^\circ\text{C}$			
Chip or operating temperature	T_j	-55 ... + 150	$^\circ\text{C}$
Storage temperature	T_{stg}	-55 ... + 150	
Thermal resistance, chip to ambient air	R_{thJA}	≤ 350	K/W
Thermal resistance, chip-substrate - reverse side ¹⁾	R_{thJSR}	≤ 285	
DIN humidity category, DIN 40 040		E	
IEC climatic category, DIN IEC 68-1		55 / 150 / 56	

1) For package mounted on aluminium 15 mm x 16.7 mm x 0.7 mm.

Electrical Characteristics, at $T_j = 25^\circ\text{C}$, unless otherwise specified

Parameter	Symbol	Values			Unit
		min.	typ.	max.	
Static Characteristics					
Drain-source breakdown voltage $V_{GS} = -10\text{ V}$, $I_D = 250\ \mu\text{A}$	$V_{(BR)DSV}$	50	-	-	V
Gate threshold voltage $V_{DS} = 3\text{ V}$, $I_D = 10\ \mu\text{A}$	$V_{GS(th)}$	-3	-2.5	-1.5	
Drain-source cutoff current $V_{DS} = 50\text{ V}$, $V_{GS} = -10\text{ V}$, $T_j = 25\ ^\circ\text{C}$ $V_{DS} = 50\text{ V}$, $V_{GS} = -10\text{ V}$, $T_j = 125\ ^\circ\text{C}$	I_{DSV}	-	-	1	μA
On-state drain current $V_{GS} = 0\text{ V}$, $V_{DS} = 10\text{ V}$	$I_{D(on)}$	70	200	-	mA
Gate-source leakage current $V_{GS} = 20\text{ V}$, $V_{DS} = 0\text{ V}$	I_{GSS}	-	10	100	nA
Drain-Source on-resistance $V_{GS} = 0\text{ V}$, $I_D = 0.07\text{ A}$	$R_{DS(on)}$	-	4	8	Ω

Electrical Characteristics, at $T_j = 25^\circ\text{C}$, unless otherwise specified

Parameter	Symbol	Values			Unit
		min.	typ.	max.	
Dynamic Characteristics					
Transconductance $V_{DS} \geq 2 * I_D * R_{DS(on)max}$, $I_D = 0.16 \text{ A}$	g_{fs}	0.1	0.16	-	S
Input capacitance $V_{GS} = -4.5 \text{ V}$, $V_{DS} = 25 \text{ V}$, $f = 1 \text{ MHz}$	C_{iss}	-	70	100	pF
Output capacitance $V_{GS} = -4.5 \text{ V}$, $V_{DS} = 25 \text{ V}$, $f = 1 \text{ MHz}$	C_{oss}	-	15	25	
Reverse transfer capacitance $V_{GS} = -4.5 \text{ V}$, $V_{DS} = 25 \text{ V}$, $f = 1 \text{ MHz}$	C_{rss}	-	6	9	
Turn-on delay time $V_{DD} = 30 \text{ V}$, $V_{GS} = -5... + 5 \text{ V}$, $I_D = 0.28 \text{ A}$ $R_{GS} = 50 \Omega$	$t_{d(on)}$	-	7	11	ns
Rise time $V_{DD} = 30 \text{ V}$, $V_{GS} = -5... + 5 \text{ V}$, $I_D = 0.28 \text{ A}$ $R_{GS} = 50 \Omega$	t_r	-	11	17	
Turn-off delay time $V_{DD} = 30 \text{ V}$, $V_{GS} = -5... + 5 \text{ V}$, $I_D = 0.28 \text{ A}$ $R_{GS} = 50 \Omega$	$t_{d(off)}$	-	13	17	
Fall time $V_{DD} = 30 \text{ V}$, $V_{GS} = -5... + 5 \text{ V}$, $I_D = 0.28 \text{ A}$ $R_{GS} = 50 \Omega$	t_f	-	14	19	

Electrical Characteristics, at $T_j = 25^\circ\text{C}$, unless otherwise specified

Parameter	Symbol	Values			Unit
		min.	typ.	max.	

Reverse Diode

Inverse diode continuous forward current $T_A = 25^\circ\text{C}$	I_S	-	-	0.1	A
Inverse diode direct current, pulsed $T_A = 25^\circ\text{C}$	I_{SM}	-	-	0.3	
Inverse diode forward voltage $V_{GS} = 0\text{ V}, I_F = 0.3\text{ A}$	V_{SD}	-	0.8	1.3	V



LittleDiode supplies new, hard to find or obsolete electronic components and semiconductors all over the world.

With over two million different components listed you are sure to find the part you need.

Feel free to visit us today at our online store:

LittleDiode.com

Looking forward to providing you with the best possible service.