



# BTA04 T/D/S/A BTB04 T/D/S/A

## SENSITIVE GATE TRIACS

### FEATURES

- Very low  $I_{GT} = 10\text{mA max}$
- Low  $I_H = 15\text{mA max}$
- BTA Family:  
Insulating voltage =  $2500V_{(RMS)}$   
(UL recognized: E81734)

### DESCRIPTION

The BTA/BTB04 T/D/S/A triac family are high performance glass passivated PNP devices. These parts are suitable for general purpose applications where gate high sensitivity is required. Application on 4Q such as phase control and static switching.

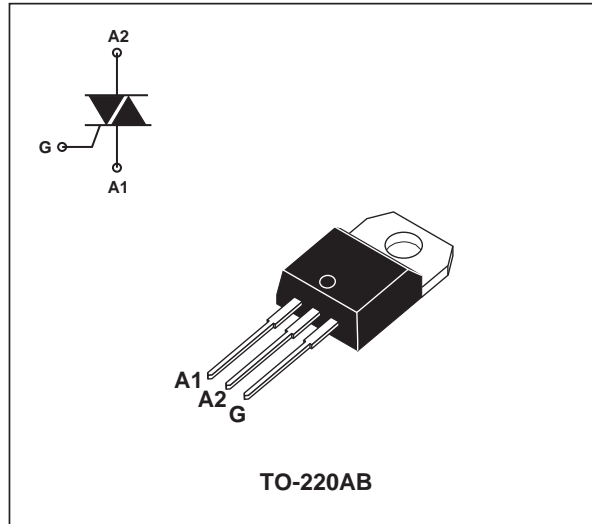

### ABSOLUTE RATINGS (limiting values)

| Symbol             | Parameter   |     | Value                           | Unit                       |                        |
|--------------------|---|-----|---------------------------------|----------------------------|------------------------|
| $I_{T(RMS)}$       | RMS on-state current (360° conduction angle)  | BTA | $T_c = 90^\circ\text{C}$        | 4                          | A                      |
|                    |   | BTB | $T_c = 95^\circ\text{C}$        |                            |                        |
| $I_{TSM}$          | Non repetitive surge peak on-state current ( $T_j$ initial = $25^\circ\text{C}$ )                                 |     | $t_p = 8.3\text{ms}$            | 42                         | A                      |
|                    |   |     | $t_p = 10\text{ms}$             |                            |                        |
| $I^2t$             | $I^2t$ value  |     | $t_p = 10\text{ms}$             | 8                          | $\text{A}^2\text{s}$   |
| $di/dt$            | Critical rate of rise of on-state current<br>Gate supply: $I_G = 50\text{mA}$ $di_G/dt = 0.1\text{A}/\mu\text{s}$ |     | Repetitive<br>$F = 50\text{Hz}$ | 10                         | $\text{A}/\mu\text{s}$ |
|                    |   |     | Non repetitive                  | 50                         |                        |
| $T_{stg}$<br>$T_j$ | Storage and operating junction temperature range  |     |                                 | -40 to +150<br>-40 to +110 | $^\circ\text{C}$       |
| $T_l$              | Maximum lead soldering temperature during 10s at 4.5mm from case  |     |                                 | 260                        | $^\circ\text{C}$       |

| Symbol                 | Parameter   | BTA / BTB04- |             |             | Unit |
|------------------------|---|--------------|-------------|-------------|------|
|                        |   | 400 T/D/S/A  | 600 T/D/S/A | 700 T/D/S/A |      |
| $V_{DRM}$<br>$V_{RRM}$ | Repetitive peak off-state voltage $T_j = 110^\circ\text{C}$ | 400          | 600         | 700         | V    |

**BTA04 T/D/S/A BTB04 T/D/S/A**

**THERMAL RESISTANCE**

| Symbol       | Parameter   | Value | Unit |
|--------------|---|-------|------|
| Rth (j-a)    | Junction to ambient                                   | 60    | °C/W |
| Rth (j-c) DC | Junction to case for DC                               | BTA   | 4.4  |
|              |   | BTB   | 3.2  |
| Rth (j-c) AC | Junction to case for 360° conduction angle (F = 50Hz) | BTA   | 3.3  |
|              |   | BTB   | 2.4  |

**GATE CHARACTERISTICS (maximum values)**

$P_{G(AV)} = 1W$   $P_{GM} = 40W$  (tp = 20µs)  $I_{GM} = 4A$  (tp = 20µs)  $V_{GM} = 16V$  (tp = 20µs)

**ELECTRICAL CHARACTERISTICS**

| Symbol                               | Test conditions   | Quadrant          |      | BTA / BTB04 |    |    |    | Unit |
|--------------------------------------|---|-------------------|------|-------------|----|----|----|------|
|                                      |   |                   |      | T           | D  | S  | A  |      |
| I <sub>GT</sub>                      | V <sub>D</sub> = 12V (DC) R <sub>L</sub> = 33Ω<br>T <sub>j</sub> = 25°C   | I - II - III      | MAX. | 5           | 5  | 10 | 10 | mA   |
|                                      |   | IV                | MAX. | 5           | 10 | 10 | 25 |      |
| V <sub>GT</sub>                      | V <sub>D</sub> = 12V (DC) R <sub>L</sub> = 33Ω<br>T <sub>j</sub> = 25°C   | I - II - III - IV | MAX. | 1.5         |    |    |    | V    |
| V <sub>GD</sub>                      | V <sub>D</sub> = V <sub>DRM</sub> R <sub>L</sub> = 3.3kΩ<br>T <sub>j</sub> = 110°C                                | I - II - III - IV | MIN. | 0.2         |    |    |    | V    |
| t <sub>gt</sub>                      | V <sub>D</sub> = V <sub>DRM</sub> I <sub>G</sub> = 40mA<br>di <sub>G</sub> /dt = 0.5A/µs<br>T <sub>j</sub> = 25°C | I - II - III - IV | TYP. | 2           |    |    |    | µs   |
| I <sub>L</sub>                       | I <sub>G</sub> = 1.2I <sub>GT</sub><br>T <sub>j</sub> = 25°C  | I - III - IV      | TYP. | 10          | 10 | 20 | 20 | mA   |
|                                      |   | II                |      | 20          | 20 | 40 | 40 |      |
| I <sub>H</sub> *                     | I <sub>T</sub> = 100mA Gate open<br>T <sub>j</sub> = 25°C   |                   | MAX. | 15          | 15 | 25 | 25 | mA   |
| V <sub>TM</sub> *                    | I <sub>TM</sub> = 5.5A tp = 380µs<br>T <sub>j</sub> = 25°C  |                   | MAX. | 1.65        |    |    |    | V    |
| I <sub>DRM</sub><br>I <sub>RRM</sub> | V <sub>DRM</sub> rated<br>V <sub>RRM</sub> rated<br>T <sub>j</sub> = 25°C   |                   | MAX. | 0.01        |    |    |    | mA   |
|                                      |   |                   | MAX. | 0.75        |    |    |    |      |
| dV/dt*                               | Linear slope up to<br>V <sub>D</sub> = 67% V <sub>DRM</sub> gate open<br>T <sub>j</sub> = 110°C                   |                   | TYP. | 10          | 10 | -  | -  | V/µs |
|                                      |   |                   | MIN. | -           | -  | 10 | 10 |      |
| (di/dt) <sub>c</sub> *               | (di/dt) <sub>c</sub> = 1.8A/ms<br>T <sub>j</sub> = 110°C  |                   | TYP. | 1           | 1  | 5  | 5  | V/µs |

\* For either polarity of electrode A<sub>2</sub> voltage with reference to electrode A<sub>1</sub>

**PRODUCT INFORMATION**

| Package              | $I_{T(RMS)}$ | $V_{DRM} / V_{RRM}$ | Sensitivity Specification |   |   |   |
|----------------------|--------------|---------------------|---------------------------|---|---|---|
|                      | A            | V                   | T                         | D | S | A |
| BTA<br>(Insulated)   | 4            | 400                 | X                         |   |   | X |
|                      |              | 600                 | X                         | X |   |   |
|                      |              | 700                 | X                         |   | X |   |
| BTB<br>(Uninsulated) |              | 400                 | X                         | X |   |   |
|                      |              | 600                 | X                         |   | X |   |

**ORDERING INFORMATION**

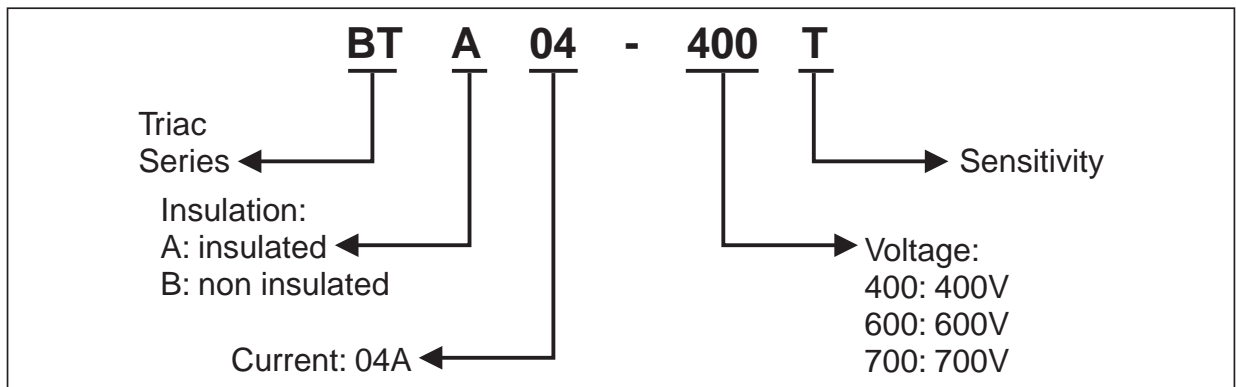

**Fig. 1:** Maximum RMS power dissipation versus RMS on-state current ( $F = 50\text{Hz}$ ). (Curves are cut off by  $(di/dt)_c$  limitation)

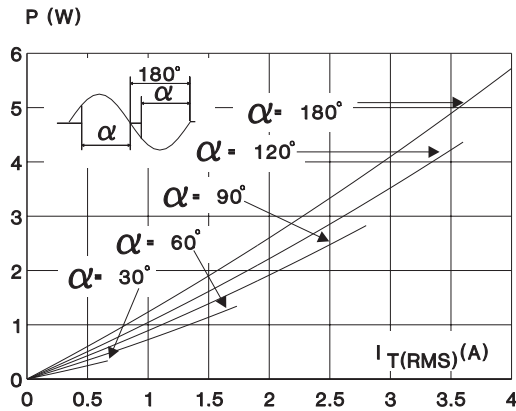

**Fig. 2:** Correlation between maximum RMS power dissipation and maximum allowable temperature ( $T_{amb}$  and  $T_{case}$ ) for different thermal resistances heatsink + contact (BTA).

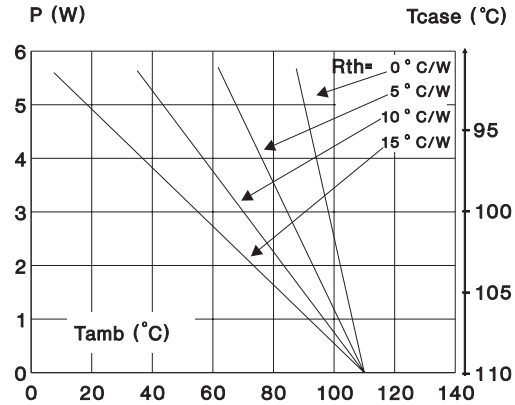

**Fig. 3:** Correlation between maximum RMS power dissipation and maximum allowable temperature ( $T_{amb}$  and  $T_{case}$ ) for different thermal resistances heatsink + contact (BTB).

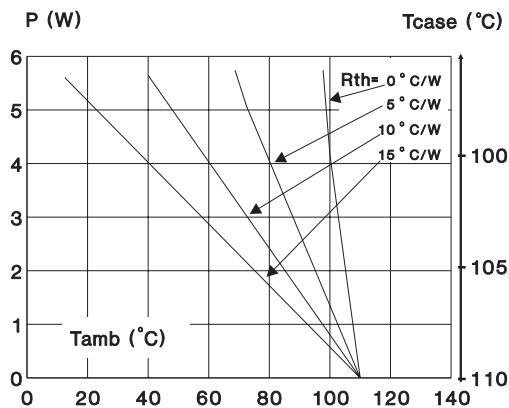

**Fig. 4:** RMS on-state current versus case temperature.

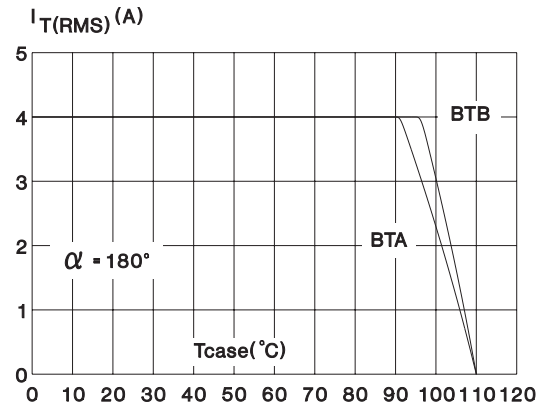

**Fig. 5:** Relative variation of thermal impedance versus pulse duration.

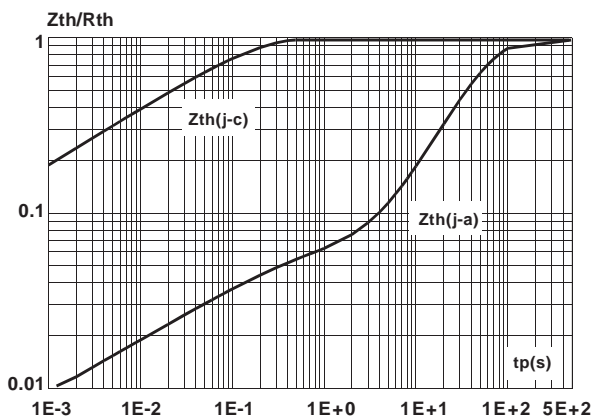

**Fig. 6:** Relative variation of gate trigger current and holding current versus junction temperature.

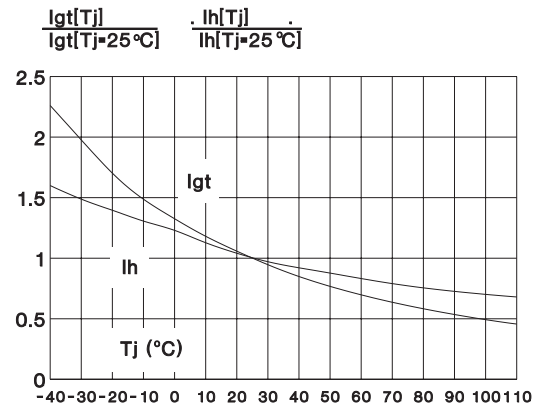

**Fig. 7:** Non repetitive surge peak on-state current versus number of cycles.

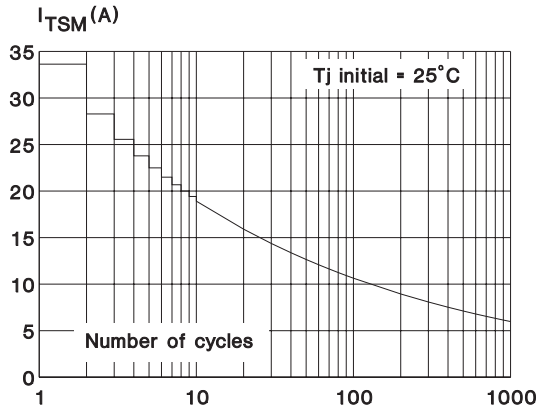

**Fig. 8:** Non repetitive surge peak on-state current for a sinusoidal pulse with width:  $t \leq 10\text{ms}$ , and corresponding value of  $I^2t$ .

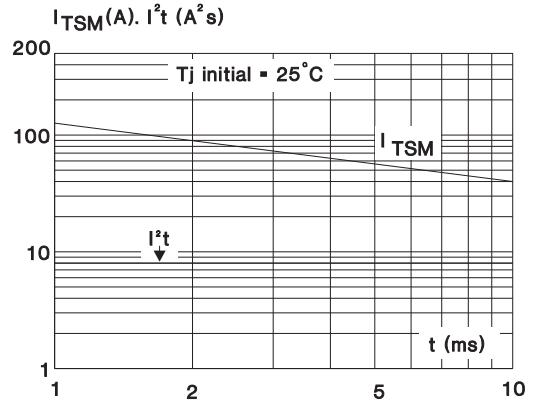

**Fig. 9:** On-state characteristics (maximum values).

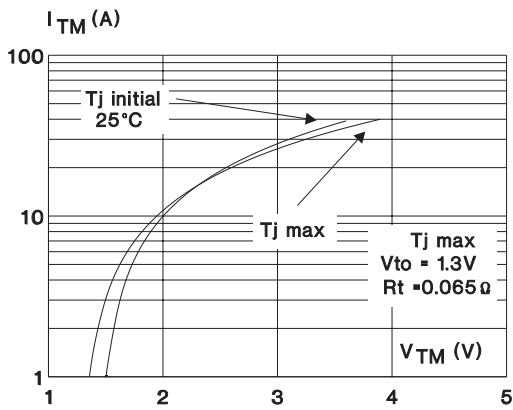

**PACKAGE MECHANICAL DATA**  
TO-220AB (Plastic)

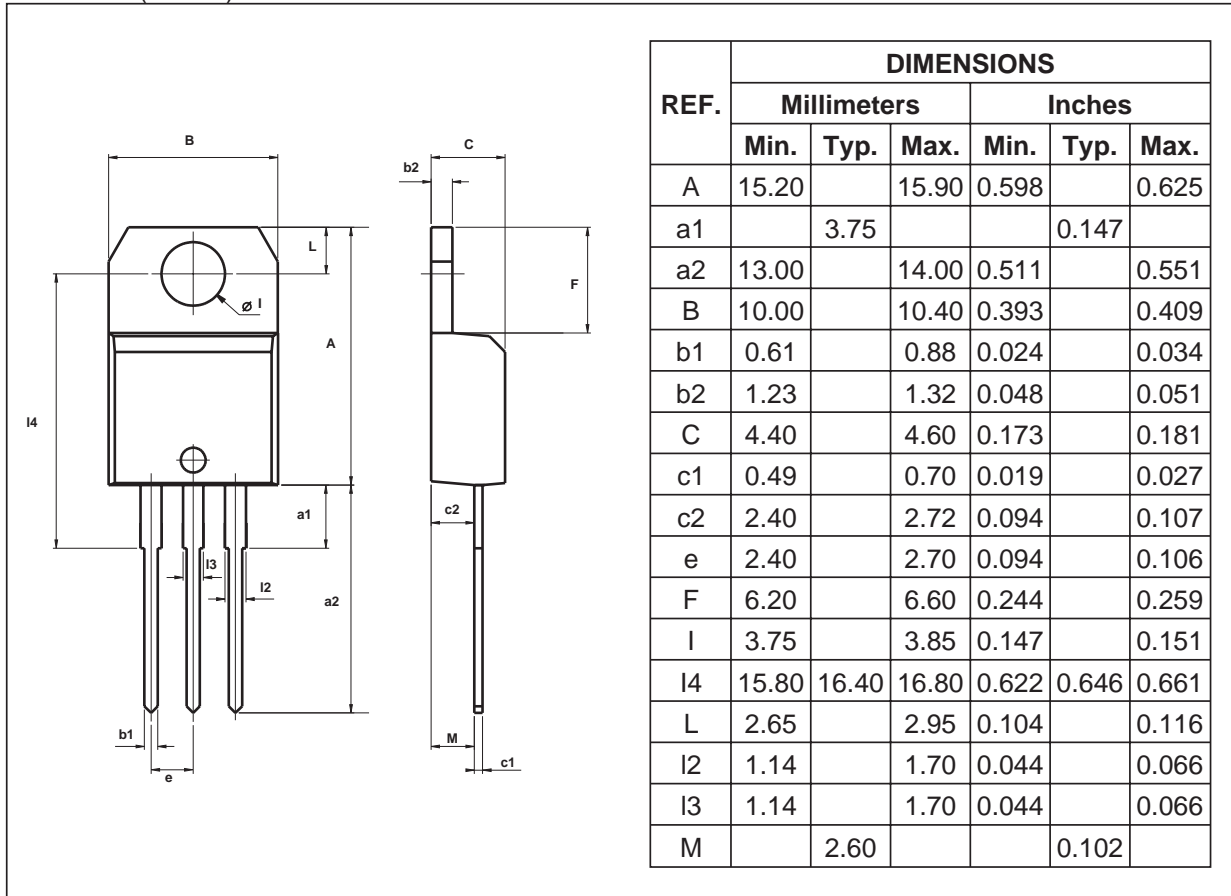

**OTHER INFORMATION**

| Ordering type  | Marking        | Package  | Weight | Base qty | Delivery mode |
|----------------|----------------|----------|--------|----------|---------------|
| BTA/BTB04-xxxx | BTA/BTB04-xxxx | TO-220AB | 2.3 g  | 250      | Bulk          |

- Epoxy meets UL94,V0
- Cooling method: C
- Recommended torque value: 0.8 m.N.
- Maximum torque value: 1 m.N.

Information furnished is believed to be accurate and reliable. However, STMicroelectronics assumes no responsibility for the consequences of use of such information nor for any infringement of patents or other rights of third parties which may result from its use. No license is granted by implication or otherwise under any patent or patent rights of STMicroelectronics. Specifications mentioned in this publication are subject to change without notice. This publication supersedes and replaces all information previously supplied. STMicroelectronics products are not authorized for use as critical components in life support devices or systems without express written approval of STMicroelectronics.

The ST logo is a registered trademark of STMicroelectronics  
© 2001 STMicroelectronics - Printed in Italy - All rights reserved.

STMicroelectronics GROUP OF COMPANIES  
Australia - Brazil - China - Finland - France - Germany - Hong Kong - India - Italy - Japan - Malaysia  
Malta - Morocco - Singapore - Spain - Sweden - Switzerland - United Kingdom - U.S.A.

<http://www.st.com>



This datasheet has been downloaded from:

[www.DatasheetCatalog.com](http://www.DatasheetCatalog.com)

Datasheets for electronic components.



LittleDiode supplies new, hard to find or obsolete electronic components and semiconductors all over the world.

With over two million different components listed you are sure to find the part you need.

Feel free to visit us today at our online store:

[LittleDiode.com](http://LittleDiode.com)

Looking forward to providing you with the best possible service.