

SWITCHMODE™

NPN Bipolar Power Transistor

For Switching Power Supply Applications

The BUL44 have an applications specific state-of-the-art die designed for use in 220 V line operated Switchmode Power supplies and electronic light ballasts. These high voltage/high speed transistors offer the following:

- Improved Efficiency Due to Low Base Drive Requirements:
 - High and Flat DC Current Gain h_{FE}
 - Fast Switching
 - No Coil Required in Base Circuit for Turn-Off (No Current Tail)
- Full Characterization at 125°C
- Tight Parametric Distributions are Consistent Lot-to-Lot

MAXIMUM RATINGS

Rating	Symbol	Value	Unit
Collector–Emitter Sustaining Voltage	V_{CEO}	400	Vdc
Collector–Emitter Breakdown Voltage	V_{CES}	700	Vdc
Emitter–Base Voltage	V_{EBO}	9.0	Vdc
Collector Current — Continuous	I_C	2.0	Adc
— Peak(1)	I_{CM}	5.0	
Base Current — Continuous	I_B	1.0	Adc
— Peak(1)	I_{BM}	2.0	
Total Device Dissipation (T _C = 25°C)	P_D	50	Watts
Derate above 25°C		0.4	W/°C
Operating and Storage Temperature	T _J , T _{stg}	– 65 to 150	°C

THERMAL CHARACTERISTICS

Rating	Symbol	Max	Unit
Thermal Resistance — Junction to Case	$R_{\theta JC}$	2.5	°C/W
— Junction to Ambient	$R_{\theta JA}$	62.5	
Maximum Lead Temperature for Soldering Purposes: 1/8" from Case for 5 Seconds	T _L	260	°C

BUL44

POWER TRANSISTOR
2.0 AMPERES
700 VOLTS
40 and 100 WATTS

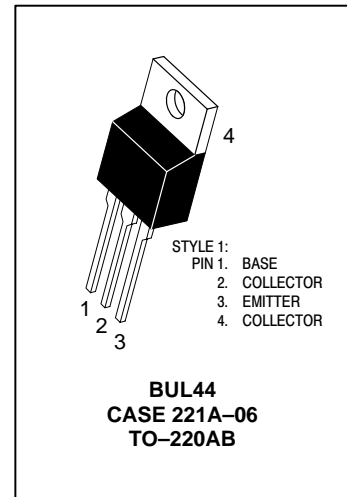

BUL44

ELECTRICAL CHARACTERISTICS (T_C = 25°C unless otherwise noted)

Characteristic	Symbol	Min	Typ	Max	Unit
----------------	--------	-----	-----	-----	------

OFF CHARACTERISTICS

Collector–Emitter Sustaining Voltage (I _C = 100 mA, L = 25 mH)	V _{CEO(sus)}	400	—	—	Vdc
Collector Cutoff Current (V _{CE} = Rated V _{CEO} , I _B = 0)	I _{CEO}	—	—	100	μAdc
Collector Cutoff Current (V _{CE} = Rated V _{CES} , V _{EB} = 0) (T _C = 125°C)	I _{CES}	—	—	100	μAdc
(V _{CE} = 500 V, V _{EB} = 0) (T _C = 125°C)		—	—	500	
		—	—	100	
Emitter Cutoff Current (V _{EB} = 9.0 Vdc, I _C = 0)	I _{EBO}	—	—	100	μAdc

ON CHARACTERISTICS

Base–Emitter Saturation Voltage (I _C = 0.4 Adc, I _B = 40 mAdc) (I _C = 1.0 Adc, I _B = 0.2 Adc)	V _{BE(sat)}	— —	0.85 0.92	1.1 1.25	Vdc
Collector–Emitter Saturation Voltage (I _C = 0.4 Adc, I _B = 40 mAdc)	V _{CE(sat)}	—	0.20	0.5	Vdc
(I _C = 1.0 Adc, I _B = 0.2 Adc) (T _C = 125°C)		—	0.20	0.5	
(I _C = 1.0 Adc, I _B = 0.2 Adc) (T _C = 125°C)		—	0.25	0.6	
(I _C = 1.0 Adc, I _B = 0.2 Adc) (T _C = 125°C)		—	0.25	0.6	
DC Current Gain (I _C = 0.2 Adc, V _{CE} = 5.0 Vdc)	h _{FE}	14	—	34	—
(I _C = 0.4 Adc, V _{CE} = 1.0 Vdc) (T _C = 125°C)		—	32	—	
(I _C = 0.4 Adc, V _{CE} = 1.0 Vdc) (T _C = 125°C)		12	20	—	
(I _C = 1.0 Adc, V _{CE} = 1.0 Vdc) (T _C = 125°C)		12	20	—	
(I _C = 1.0 Adc, V _{CE} = 1.0 Vdc) (T _C = 125°C)		8.0	14	—	
(I _C = 10 mAdc, V _{CE} = 5.0 Vdc) (T _C = 125°C)		7.0	13	—	
(I _C = 10 mAdc, V _{CE} = 5.0 Vdc) (T _C = 125°C)		10	22	—	

DYNAMIC CHARACTERISTICS

Current Gain Bandwidth (I _C = 0.5 Adc, V _{CE} = 10 Vdc, f = 1.0 MHz)	f _T	—	13	—	MHz	
Output Capacitance (V _{CB} = 10 Vdc, I _E = 0, f = 1.0 MHz)	C _{OB}	—	38	60	pF	
Input Capacitance (V _{EB} = 8.0 V)	C _{IB}	—	380	600	pF	
Dynamic Saturation Voltage: Determined 1.0 μs and 3.0 μs respectively after rising I _{B1} reaches 90% of final I _{B1}	(I _C = 0.4 Adc, I _{B1} = 40 mAdc, V _{CC} = 300 V)	1.0 μs (T _C = 125°C)	—	2.5	—	Vdc
		3.0 μs (T _C = 125°C)	—	2.7	—	
	(I _C = 1.0 Adc, I _{B1} = 0.2 Adc, V _{CC} = 300 V)	1.0 μs (T _C = 125°C)	—	1.3	—	
		3.0 μs (T _C = 125°C)	—	1.15	—	
		1.0 μs (T _C = 125°C)	—	3.2	—	
		3.0 μs (T _C = 125°C)	—	7.5	—	
			—	1.25	—	
			—	1.6	—	

(1) Pulse Test: Pulse Width = 5.0 ms, Duty Cycle ≤ 10%.

(continued)

BUL44

SWITCHING CHARACTERISTICS: Resistive Load (D.C. ≤ 10%, Pulse Width = 20 μs)

Turn-On Time	(I _C = 0.4 Adc, I _{B1} = 40 mAdc I _{B2} = 0.2 Adc, V _{CC} = 300 V) (T _C = 125°C)	t _{on}	—	40	100	ns
Turn-Off Time		t _{off}	—	40	—	—
Turn-On Time	(I _C = 0.4 Adc, I _{B1} = 40 mAdc I _{B2} = 0.2 Adc, V _{CC} = 300 V) (T _C = 125°C)	t _{on}	—	1.5	2.5	μs
Turn-Off Time		t _{off}	—	2.0	—	—
Turn-On Time	(I _C = 1.0 Adc, I _{B1} = 0.2 Adc I _{B1} = 0.5 Adc, V _{CC} = 300 V) (T _C = 125°C)	t _{on}	—	85	150	ns
Turn-Off Time		t _{off}	—	85	—	—
Turn-On Time	(I _C = 1.0 Adc, I _{B1} = 0.2 Adc I _{B2} = 0.5 Adc, V _{CC} = 300 V) (T _C = 125°C)	t _{on}	—	1.75	2.5	μs
Turn-Off Time		t _{off}	—	2.10	—	—

SWITCHING CHARACTERISTICS: Inductive Load (V_{clamp} = 300 V, V_{CC} = 15 V, L = 200 μH)

Fall Time	(I _C = 0.4 Adc, I _{B1} = 40 mAdc I _{B2} = 0.2 Adc) (T _C = 125°C)	t _{fi}	—	125	200	ns
Storage Time		t _{si}	—	120	—	—
Crossover Time		t _c	—	0.7	1.25	μs
Fall Time	(I _C = 0.4 Adc, I _{B1} = 40 mAdc I _{B2} = 0.2 Adc) (T _C = 125°C)	t _{fi}	—	0.8	—	—
Storage Time		t _{si}	—	110	200	ns
Crossover Time		t _c	—	110	—	—
Fall Time	(I _C = 1.0 Adc, I _{B1} = 0.2 Adc I _{B2} = 0.5 Adc) (T _C = 125°C)	t _{fi}	—	110	175	ns
Storage Time		t _{si}	—	120	—	—
Crossover Time		t _c	—	1.7	2.75	μs
Fall Time	(I _C = 1.0 Adc, I _{B1} = 0.2 Adc I _{B2} = 0.5 Adc) (T _C = 125°C)	t _{fi}	—	2.25	—	—
Storage Time		t _{si}	—	180	300	ns
Crossover Time		t _c	—	210	—	—
Fall Time	(I _C = 0.8 Adc, I _{B1} = 160 mAdc I _{B2} = 160 mAdc) (T _C = 125°C)	t _{fi}	70	—	170	ns
Storage Time		t _{si}	—	180	—	—
Crossover Time		t _c	2.6	—	3.8	μs
Fall Time	(I _C = 0.8 Adc, I _{B1} = 160 mAdc I _{B2} = 160 mAdc) (T _C = 125°C)	t _{fi}	—	4.2	—	—
Storage Time		t _{si}	—	190	300	ns
Crossover Time		t _c	—	350	—	—

TYPICAL STATIC CHARACTERISTICS

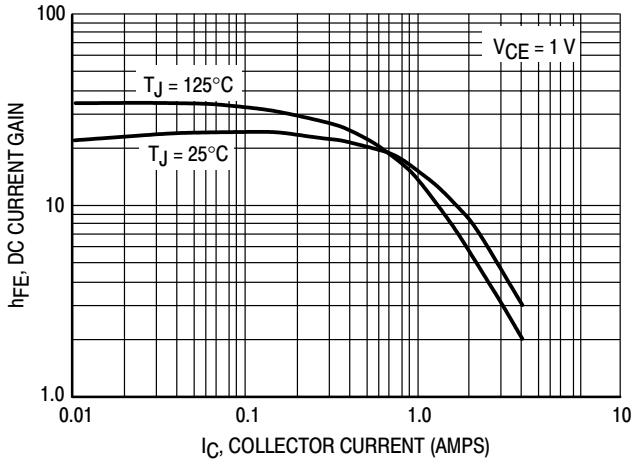

Figure 1. DC Current Gain at 1 Volt

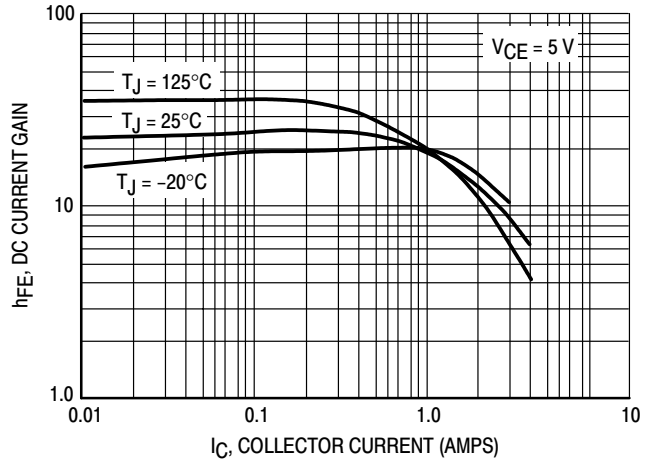

Figure 2. DC Current Gain at 5 Volts

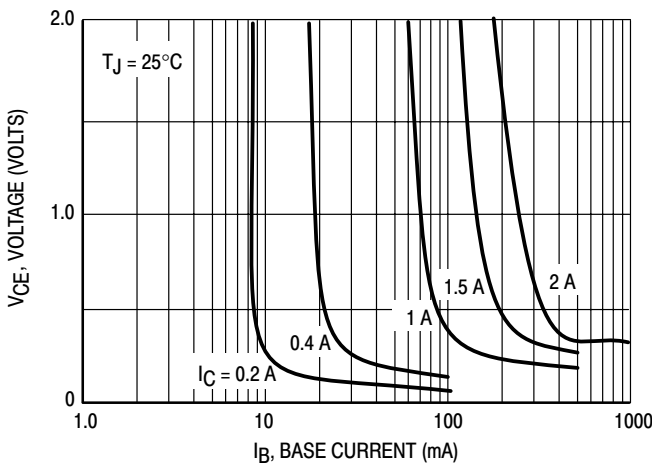

Figure 3. Collector Saturation Region

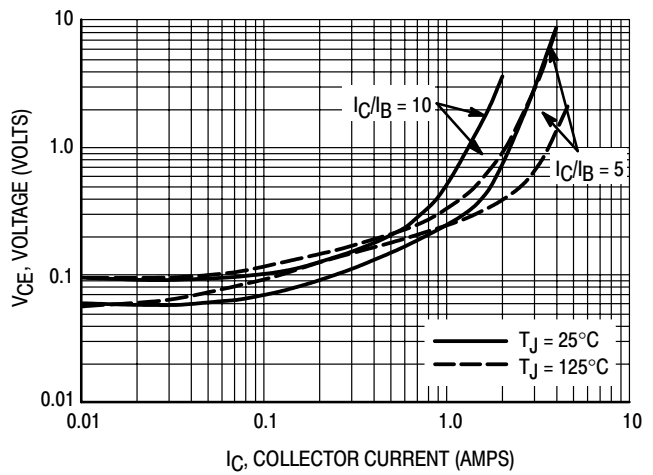

Figure 4. Collector-Emitter Saturation Voltage

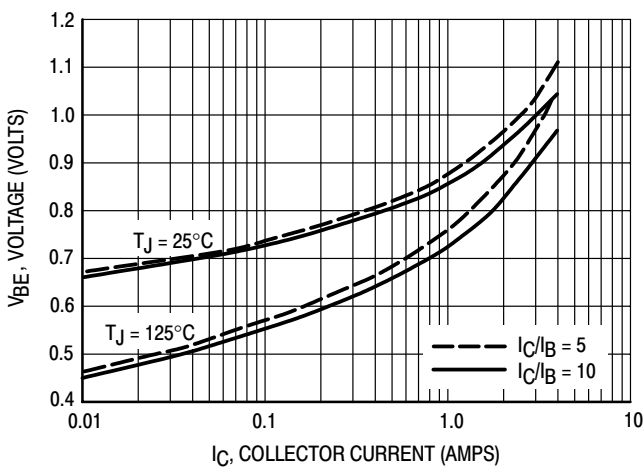

Figure 5. Base-Emitter Saturation Region

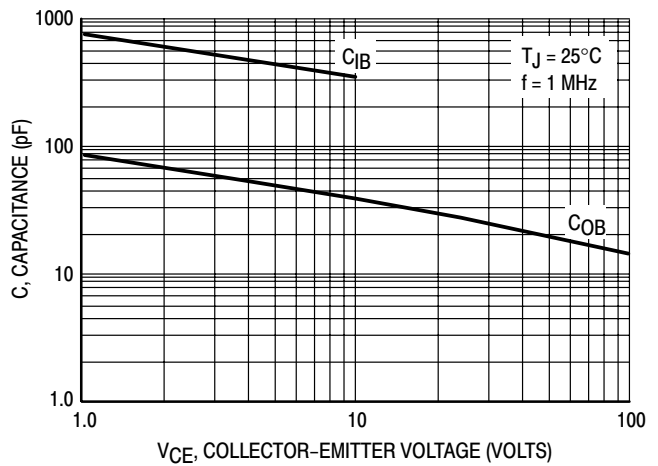

Figure 6. Capacitance

TYPICAL SWITCHING CHARACTERISTICS
($I_{B2} = I_C/2$ for all switching)

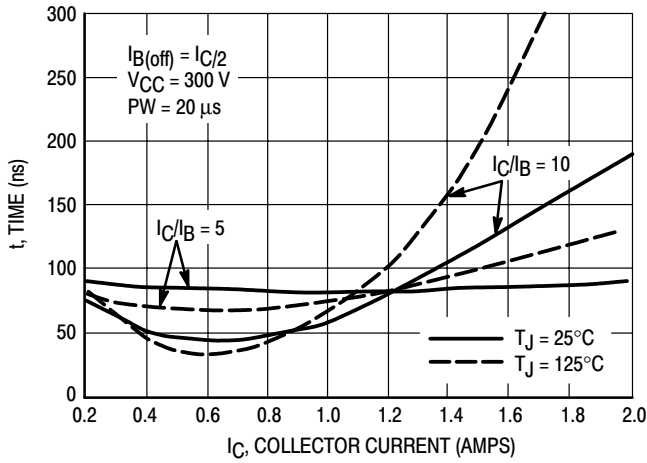

Figure 7. Resistive Switching, t_{on}

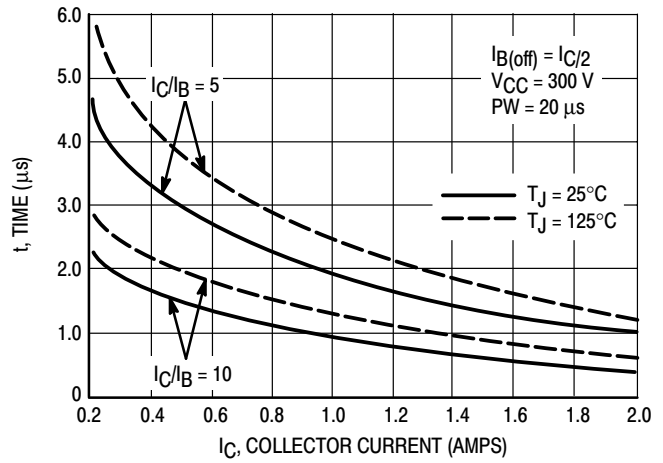

Figure 8. Resistive Switching, t_{off}

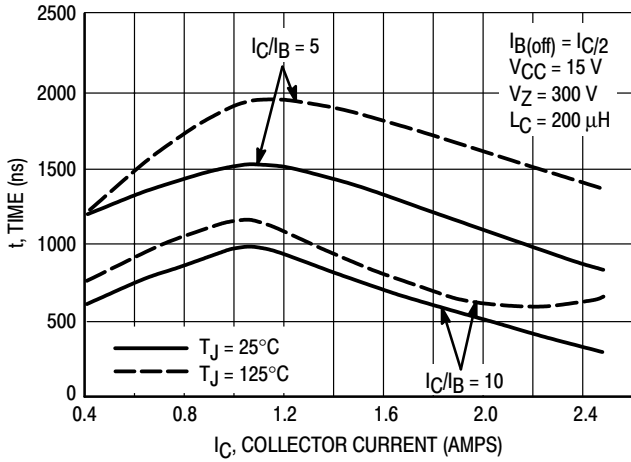

Figure 9. Inductive Storage Time, t_{si}

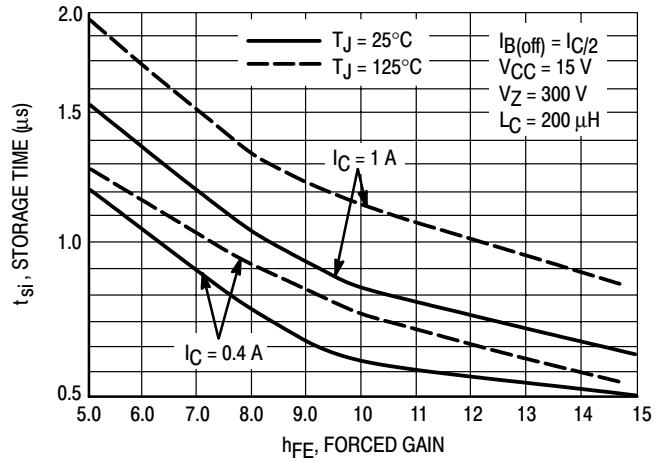

Figure 10. Inductive Storage Time

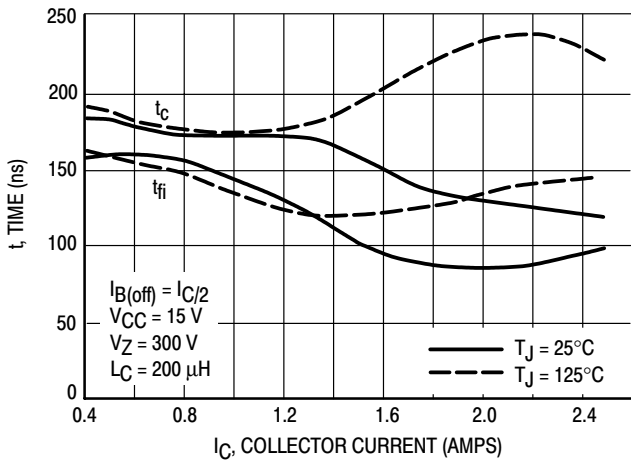

Figure 11. Inductive Switching, t_c and t_{fi} $I_C/I_B = 5$

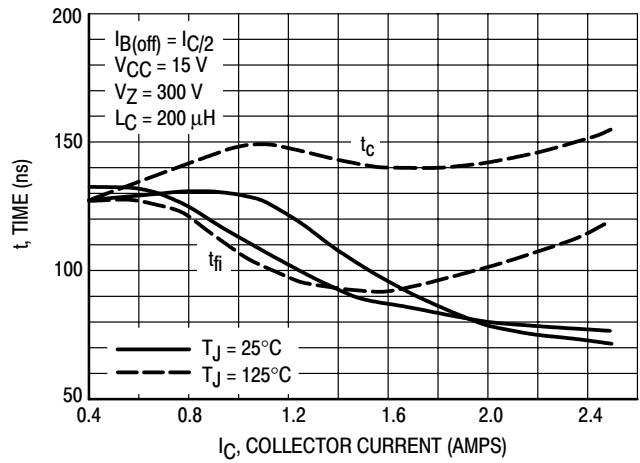

Figure 12. Inductive Switching, t_c and t_{fi} $I_C/I_B = 10$

TYPICAL SWITCHING CHARACTERISTICS
($I_{B2} = I_C/2$ for all switching)

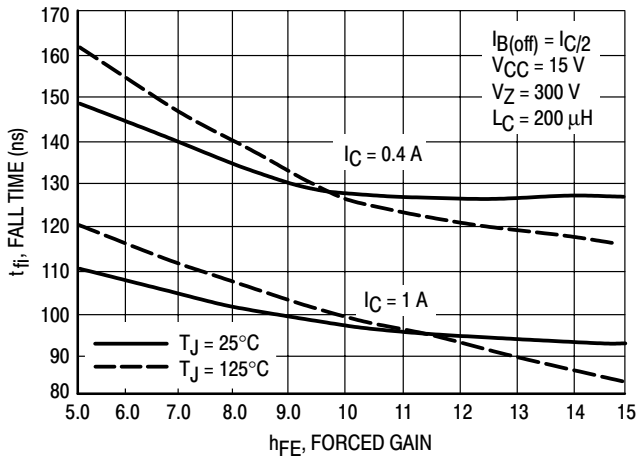

Figure 13. Inductive Fall Time

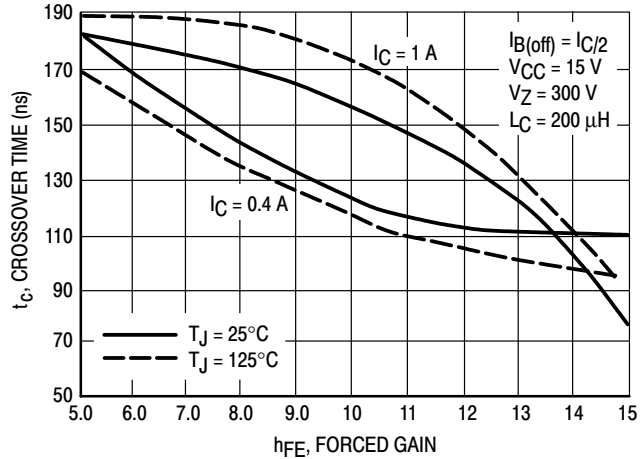

Figure 14. Inductive Crossover Time

GUARANTEED SAFE OPERATING AREA INFORMATION

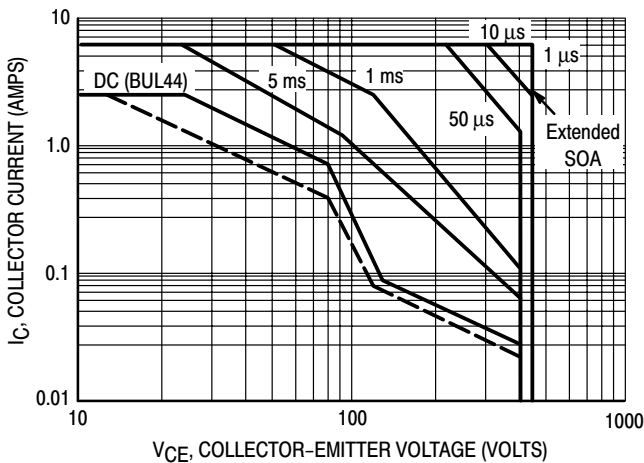

Figure 15. Forward Bias Safe Operating Area

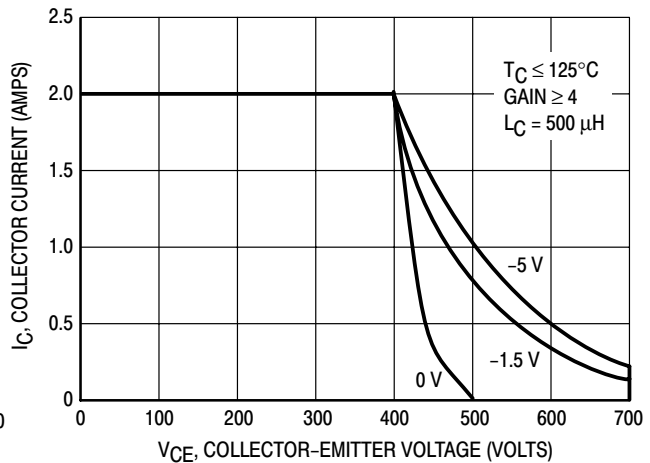

Figure 16. Reverse Bias Switching Safe Operating Area

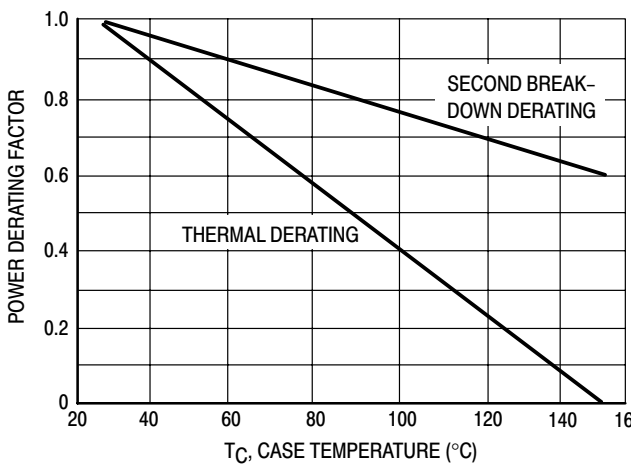

Figure 17. Forward Bias Power Derating

There are two limitations on the power handling ability of a transistor: average junction temperature and second breakdown. Safe operating area curves indicate I_C - V_{CE}

limits of the transistor that must be observed for reliable operation; i.e., the transistor must not be subjected to greater dissipation than the curves indicate. The data of figure 15 is based on $T_C = 25^\circ\text{C}$; $T_J(\text{PK})$ is variable depending on power level. Second breakdown pulse limits are valid for duty cycles to 10% but must be derated when $T_C > 25^\circ\text{C}$. Second breakdown limitations do not derate the same as thermal limitations. Allowable current at the voltages shown on figure 15 may be found at any case temperature by using the appropriate curve on figure 17. $T_J(\text{PK})$ may be calculated from the data in figure 20. At any case temperatures, thermal limitations will reduce the power than can be handled to values less than the limitations imposed by second breakdown. For inductive loads, high voltage and current must be sustained simultaneously during turn-off with the base-to-emitter junction reverse-biased. The safe level is specified as a reverse-biased safe operating area (Figure 16). This rating is verified under clamped conditions so that the device is never subjected to an avalanche mode.

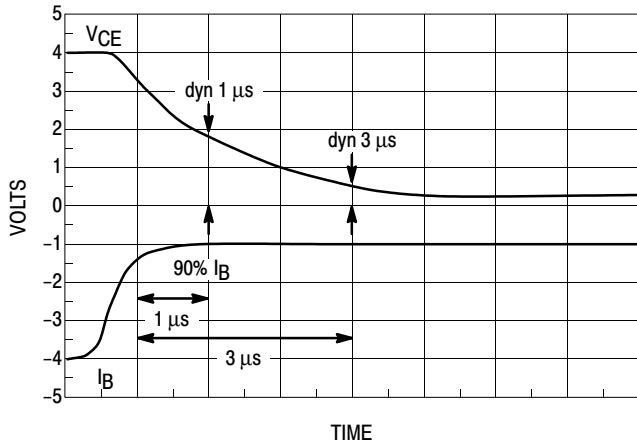

Figure 18. Dynamic Saturation Voltage Measurements

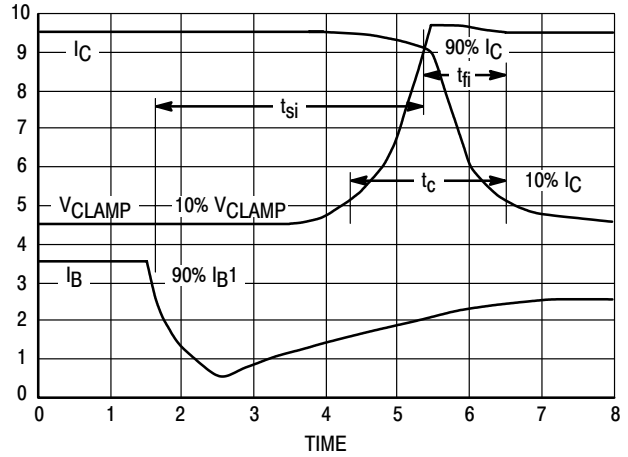
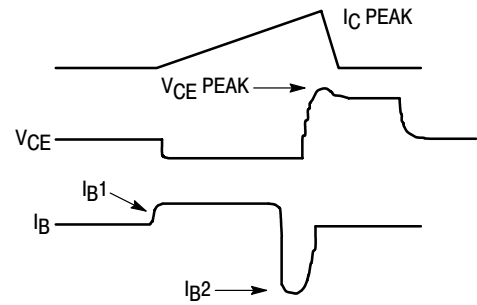
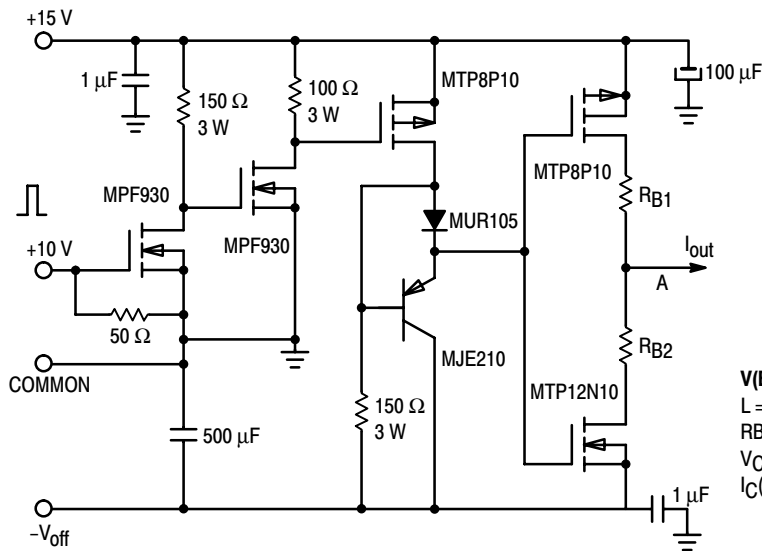

Figure 19. Inductive Switching Measurements



V(BR)CEO(sus)	INDUCTIVE SWITCHING	RBSOA
L = 10 mH	L = 200 μH	L = 500 μH
RB2 = ∞	RB2 = 0	RB2 = 0
VCC = 20 VOLTS	VCC = 15 VOLTS	VCC = 15 VOLTS
IC(pk) = 100 mA	RB1 SELECTED FOR DESIRED IB1	RB1 SELECTED FOR DESIRED IB1

Table 1. Inductive Load Switching Drive Circuit

TYPICAL THERMAL RESPONSE

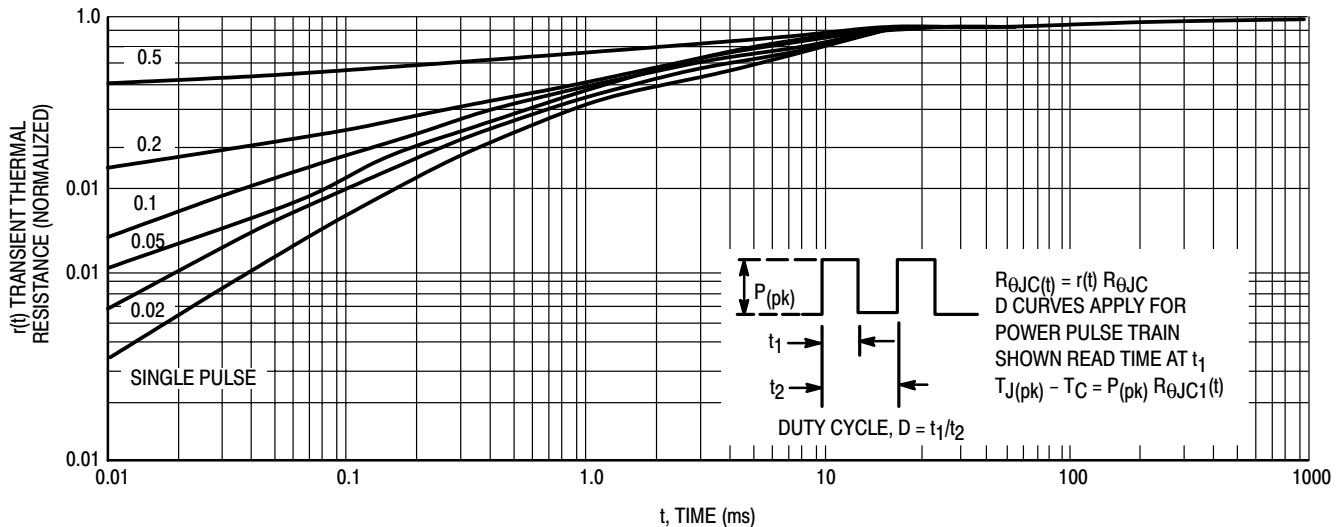
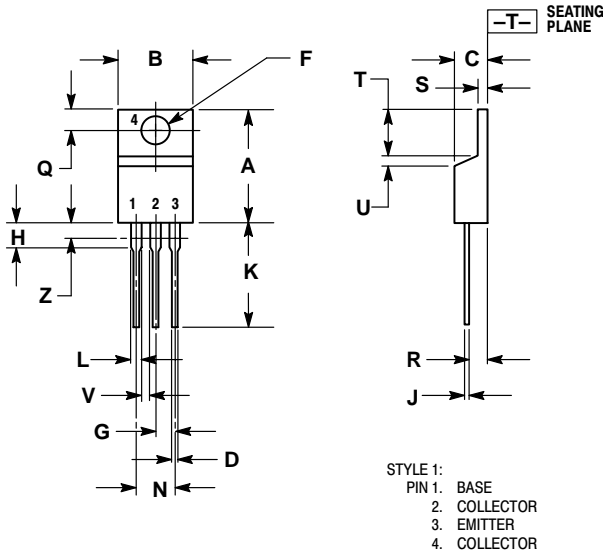

Figure 20. Typical Thermal Response ($Z_{\theta JC}(t)$) for BUL44

BUL44

PACKAGE DIMENSIONS

TO-220AB CASE 221A-09 ISSUE AA



NOTES:

1. DIMENSIONING AND TOLERANCING PER ANSI Y14.5M, 1982.
2. CONTROLLING DIMENSION: INCH.
3. DIMENSION Z DEFINES A ZONE WHERE ALL BODY AND LEAD IRREGULARITIES ARE ALLOWED.

DIM	INCHES		MILLIMETERS	
	MIN	MAX	MIN	MAX
A	0.570	0.620	14.48	15.75
B	0.380	0.405	9.66	10.28
C	0.160	0.190	4.07	4.82
D	0.025	0.035	0.64	0.88
F	0.142	0.147	3.61	3.73
G	0.095	0.105	2.42	2.66
H	0.110	0.155	2.80	3.93
J	0.018	0.025	0.46	0.64
K	0.500	0.562	12.70	14.27
L	0.045	0.060	1.15	1.52
N	0.190	0.210	4.83	5.33
Q	0.100	0.120	2.54	3.04
R	0.080	0.110	2.04	2.79
S	0.045	0.055	1.15	1.39
T	0.235	0.255	5.97	6.47
U	0.000	0.050	0.00	1.27
V	0.045	---	1.15	---
Z	---	0.080	---	2.04

SWITCHMODE is a trademark of Semiconductor Components Industries, LLC.

ON Semiconductor and  are registered trademarks of Semiconductor Components Industries, LLC (SCILLC). SCILLC reserves the right to make changes without further notice to any products herein. SCILLC makes no warranty, representation or guarantee regarding the suitability of its products for any particular purpose, nor does SCILLC assume any liability arising out of the application or use of any product or circuit, and specifically disclaims any and all liability, including without limitation special, consequential or incidental damages. "Typical" parameters which may be provided in SCILLC data sheets and/or specifications can and do vary in different applications and actual performance may vary over time. All operating parameters, including "Typicals" must be validated for each customer application by customer's technical experts. SCILLC does not convey any license under its patent rights nor the rights of others. SCILLC products are not designed, intended, or authorized for use as components in systems intended for surgical implant into the body, or other applications intended to support or sustain life, or for any other application in which the failure of the SCILLC product could create a situation where personal injury or death may occur. Should Buyer purchase or use SCILLC products for any such unintended or unauthorized application, Buyer shall indemnify and hold SCILLC and its officers, employees, subsidiaries, affiliates, and distributors harmless against all claims, costs, damages, and expenses, and reasonable attorney fees arising out of, directly or indirectly, any claim of personal injury or death associated with such unintended or unauthorized use, even if such claim alleges that SCILLC was negligent regarding the design or manufacture of the part. SCILLC is an Equal Opportunity/Affirmative Action Employer.

PUBLICATION ORDERING INFORMATION

Literature Fulfillment:

Literature Distribution Center for ON Semiconductor
P.O. Box 5163, Denver, Colorado 80217 USA
Phone: 303-675-2175 or 800-344-3860 Toll Free USA/Canada
Fax: 303-675-2176 or 800-344-3867 Toll Free USA/Canada
Email: ONlit@hibbertco.com

N. American Technical Support: 800-282-9855 Toll Free USA/Canada

JAPAN: ON Semiconductor, Japan Customer Focus Center
4-32-1 Nishi-Gotanda, Shinagawa-ku, Tokyo, Japan 141-0031
Phone: 81-3-5740-2700
Email: r14525@onsemi.com

ON Semiconductor Website: <http://onsemi.com>

For additional information, please contact your local Sales Representative.



LittleDiode supplies new, hard to find or obsolete electronic components and semiconductors all over the world.

With over two million different components listed you are sure to find the part you need.

Feel free to visit us today at our online store:

LittleDiode.com

Looking forward to providing you with the best possible service.