

Designer's™ Data Sheet
NPN Silicon Power Transistor
High Voltage SWITCHMODE™ Series

Designed for use in electronic ballast (light ballast) and in Switchmode Power supplies up to 50 Watts. Main features include:

- Improved Efficiency Due to:
 - Low Base Drive Requirements (High and Flat DC Current Gain h_{FE})
 - Low Power Losses (On-State and Switching Operations)
 - Fast Switching: $t_{fi} = 100$ ns (typ) and $t_{sj} = 3.2$ μ s (typ)
@ $I_C = 2.0$ A, $I_{B1} = I_{B2} = 0.4$ A
- Full Characterization at 125°C
- Tight Parametric Distributions Consistent Lot-to-Lot
- BUL45F, Case 221D, is UL Recognized at 3500 V_{RMS}: File #E69369

MAXIMUM RATINGS

Rating	Symbol	BUL45	BUL45F	Unit
Collector-Emitter Sustaining Voltage	V_{CEO}	400		Vdc
Collector-Emitter Breakdown Voltage	V_{CES}	700		Vdc
Emitter-Base Voltage	V_{EBO}	9.0		Vdc
Collector Current — Continuous	I_C	5.0		Adc
— Peak(1)	I_{CM}	10		
Base Current	I_B	2.0		Adc
RMS Isolated Voltage(2)	V_{ISOL}	—	4500	Volts
(for 1 sec, R.H. < 30%, $T_C = 25^\circ\text{C}$)		—	3500	
		—	1500	
Total Device Dissipation Derate above 25°C	P_D	75 0.6	35 0.28	Watts W/°C
Operating and Storage Temperature	T_J, T_{stg}	- 65 to 150		°C

THERMAL CHARACTERISTICS

Rating	Symbol	MJE18006	MJF18006	Unit
Thermal Resistance — Junction to Case	$R_{\theta JC}$	1.65	3.55	°C/W
— Junction to Ambient	$R_{\theta JA}$	62.5	62.5	

ELECTRICAL CHARACTERISTICS ($T_C = 25^\circ\text{C}$ unless otherwise noted)

Characteristic	Symbol	Min	Typ	Max	Unit
----------------	--------	-----	-----	-----	------

OFF CHARACTERISTICS

Collector-Emitter Sustaining Voltage ($I_C = 100$ mA, $L = 25$ mH)	$V_{CEO(sus)}$	400	—	—	Vdc
Collector Cutoff Current ($V_{CE} = \text{Rated } V_{CEO}, I_B = 0$)	I_{CEO}	—	—	100	μ Adc
Collector Cutoff Current ($V_{CE} = \text{Rated } V_{CES}, V_{EB} = 0$)	I_{CES}	—	—	10	μ Adc
		—	—	100	
Emitter Cutoff Current ($V_{EB} = 9.0$ Vdc, $I_C = 0$)	I_{EBO}	—	—	100	μ Adc

(1) Pulse Test: Pulse Width = 5.0 ms, Duty Cycle \leq 10%.

(2) Proper strike and creepage distance must be provided.

(continued)

Designer's and SWITCHMODE are trademarks of Motorola, Inc.

Designer's Data for "Worst Case" Conditions — The Designer's Data Sheet permits the design of most circuits entirely from the information presented. SOA Limit curves — representing boundaries on device characteristics — are given to facilitate "worst case" design.

Preferred devices are Motorola recommended choices for future use and best overall value.

REV 2

BUL45*
BUL45F*

*Motorola Preferred Device

POWER TRANSISTOR
5.0 AMPERES
700 VOLTS
35 and 75 WATTS

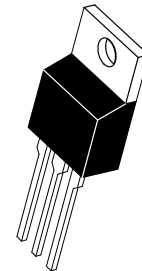

BUL45
CASE 221A-06
TO-220AB

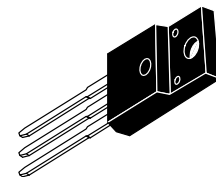

BUL45F
CASE 221D-02
ISOLATED TO-220 TYPE
UL RECOGNIZED

BUL45 BUL45F

ELECTRICAL CHARACTERISTICS — continued ($T_C = 25^\circ\text{C}$ unless otherwise noted)

Characteristic	Symbol	Min	Typ	Max	Unit
ON CHARACTERISTICS					
Base–Emitter Saturation Voltage ($I_C = 1.0 \text{ Adc}$, $I_B = 0.2 \text{ Adc}$) ($I_C = 2.0 \text{ Adc}$, $I_B = 0.4 \text{ Adc}$)	$V_{BE(sat)}$	— —	0.84 0.89	1.2 1.25	Vdc
Collector–Emitter Saturation Voltage ($I_C = 1.0 \text{ Adc}$, $I_B = 0.2 \text{ Adc}$) ($T_C = 125^\circ\text{C}$)	$V_{CE(sat)}$	— —	0.175 0.150	0.25 —	Vdc
Collector–Emitter Saturation Voltage ($I_C = 2.0 \text{ Adc}$, $I_B = 0.4 \text{ Adc}$) ($T_C = 125^\circ\text{C}$)	$V_{CE(sat)}$	— —	0.25 0.275	0.4 —	Vdc
DC Current Gain ($I_C = 0.3 \text{ Adc}$, $V_{CE} = 5.0 \text{ Vdc}$) ($I_C = 2.0 \text{ Adc}$, $V_{CE} = 1.0 \text{ Vdc}$) ($I_C = 10 \text{ mAdc}$, $V_{CE} = 5.0 \text{ Vdc}$) ($T_C = 125^\circ\text{C}$)	h_{FE}	14 — 7.0 5.0 10	— 32 14 12 22	34 — — — —	—

DYNAMIC CHARACTERISTICS

Current Gain Bandwidth ($I_C = 0.5 \text{ Adc}$, $V_{CE} = 10 \text{ Vdc}$, $f = 1.0 \text{ MHz}$)	f_T	—	12	—	MHz			
Output Capacitance ($V_{CB} = 10 \text{ Vdc}$, $I_E = 0$, $f = 1.0 \text{ MHz}$)	C_{ob}	—	50	75	pF			
Input Capacitance ($V_{EB} = 8.0 \text{ Vdc}$)	C_{ib}	—	920	1200	pF			
Dynamic Saturation Voltage: Determined 1.0 μs and 3.0 μs respectively after rising I_{B1} reaches 90% of final I_{B1} (see Figure 18)	V_{CE} (Dyn sat)	$(I_C = 1.0 \text{ Adc}$ $I_{B1} = 100 \text{ mAdc}$ $V_{CC} = 300 \text{ V}$)	1.0 μs	$(T_C = 125^\circ\text{C})$	— —	1.75 4.4	— —	Vdc
3.0 μs			$(T_C = 125^\circ\text{C})$	— —	0.5 1.0	— —		
$(I_C = 2.0 \text{ Adc}$ $I_{B1} = 400 \text{ mAdc}$ $V_{CC} = 300 \text{ V}$)		1.0 μs	$(T_C = 125^\circ\text{C})$	— —	1.85 6.0	— —		
		3.0 μs	$(T_C = 125^\circ\text{C})$	— —	0.5 1.0	— —		

SWITCHING CHARACTERISTICS: Resistive Load

Turn–On Time	$(I_C = 2.0 \text{ Adc}$, $I_{B1} = I_{B2} = 0.4 \text{ Adc}$ Pulse Width = 20 μs , Duty Cycle < 20% $V_{CC} = 300 \text{ V}$) ($T_C = 125^\circ\text{C}$)	t_{on}	— —	75 120	110 —	ns
Turn–Off Time		t_{off}	— —	2.8 3.5	3.5 —	μs

SWITCHING CHARACTERISTICS: Inductive Load ($V_{CC} = 15 \text{ Vdc}$, $L_C = 200 \mu\text{H}$, $V_{clamp} = 300 \text{ Vdc}$)

Fall Time	$(I_C = 2.0 \text{ Adc}$, $I_{B1} = 0.4 \text{ Adc}$ $I_{B2} = 0.4 \text{ Adc}$) ($T_C = 125^\circ\text{C}$)	t_{fi}	70 —	— 200	170 —	ns
Storage Time		t_{si}	2.6 —	— 4.2	3.8 —	μs
Crossover Time		t_c	— —	230 400	350 —	ns
Fall Time	$(I_C = 1.0 \text{ Adc}$, $I_{B1} = 100 \text{ mAdc}$ $I_{B2} = 0.5 \text{ Adc}$) ($T_C = 125^\circ\text{C}$)	t_{fi}	— —	110 100	150 —	ns
Storage Time		t_{si}	— —	1.1 1.5	1.7 —	μs
Crossover Time		t_c	— —	170 170	250 —	ns
Fall Time	$(I_C = 2.0 \text{ Adc}$, $I_{B1} = 250 \text{ mAdc}$ $I_{B2} = 2.0 \text{ Adc}$) ($T_C = 125^\circ\text{C}$)	t_{fi}	—	80	120	ns
Storage Time		t_{si}	—	0.6	0.9	μs
Crossover Time		t_c	—	175	300	ns

TYPICAL STATIC CHARACTERISTICS

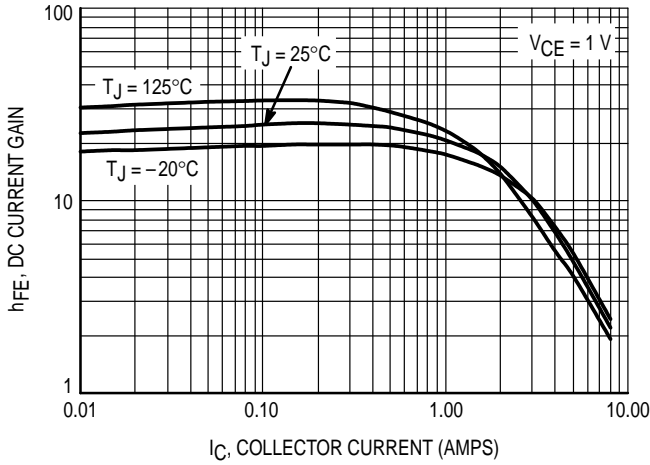

Figure 1. DC Current Gain @ 1 Volt

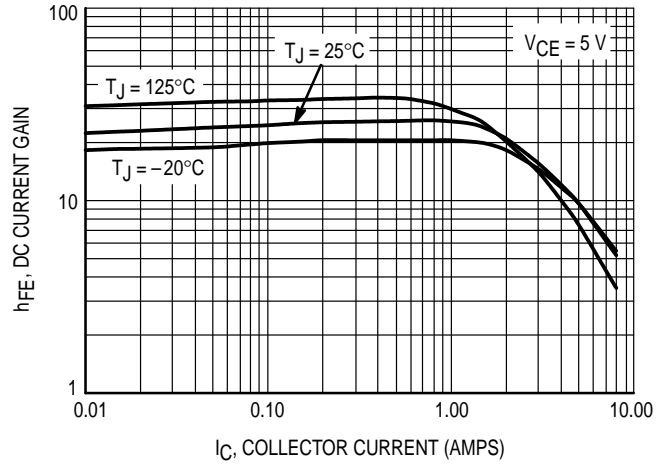

Figure 2. DC Current Gain at @ 5 Volts

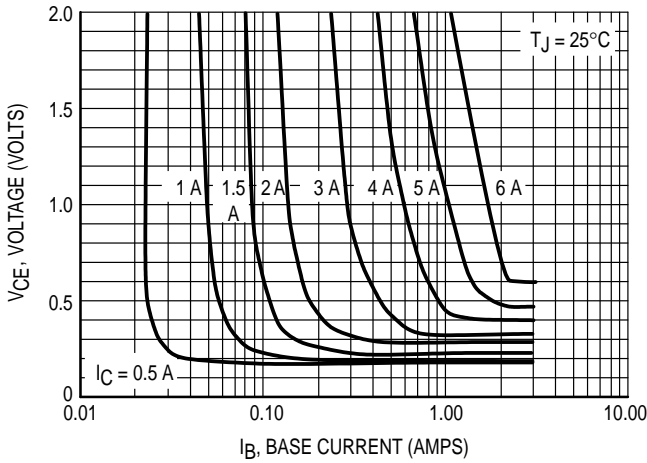

Figure 3. Collector-Emitter Saturation Region

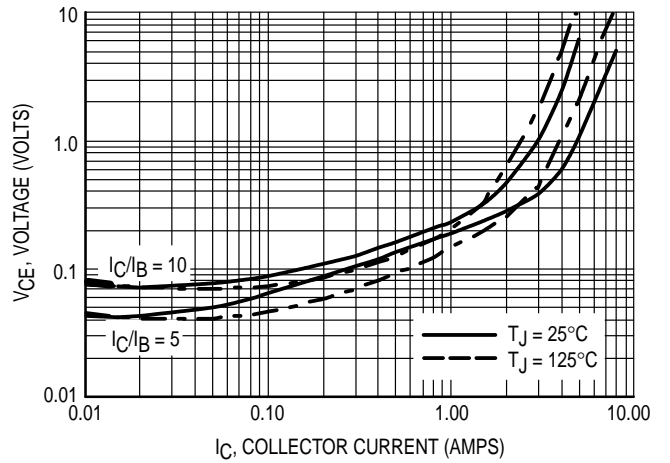

Figure 4. Collector-Emitter Saturation Voltage

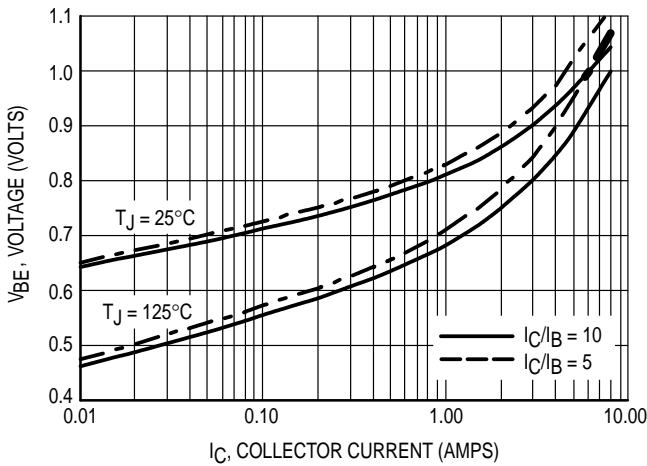

Figure 5. Base-Emitter Saturation Region

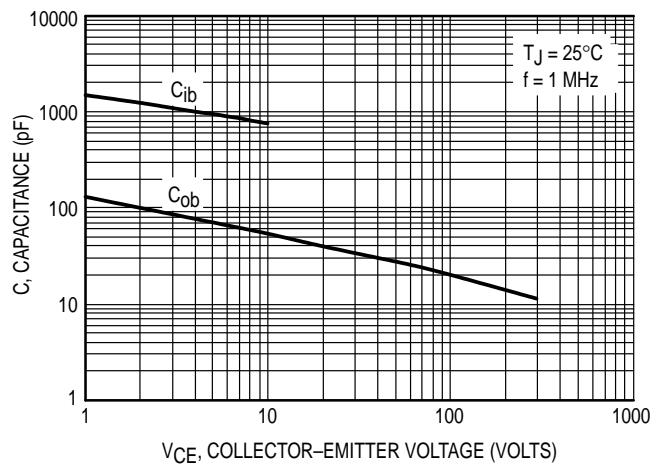

Figure 6. Capacitance

TYPICAL SWITCHING CHARACTERISTICS
($I_{B2} = I_C/2$ for all switching)

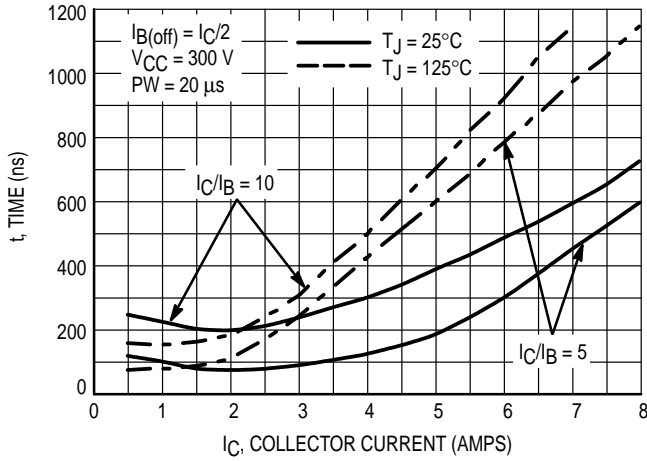

Figure 7. Resistive Switching, t_{on}

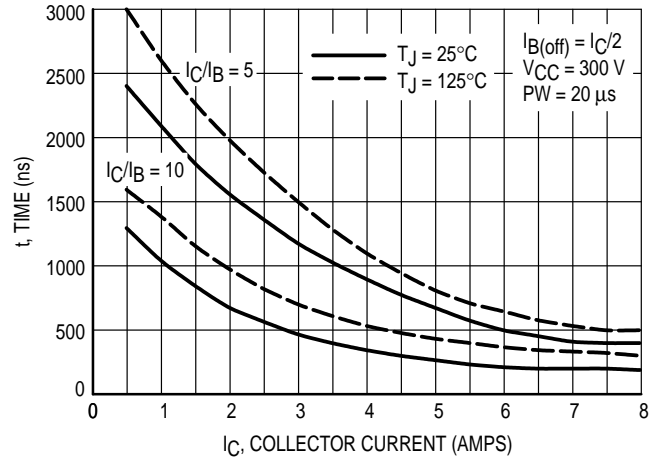

Figure 8. Resistive Switching, t_{off}

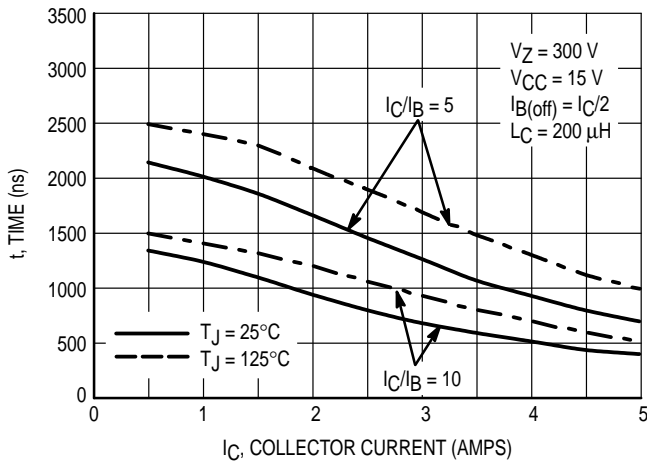

Figure 9. Inductive Storage Time, t_{si}

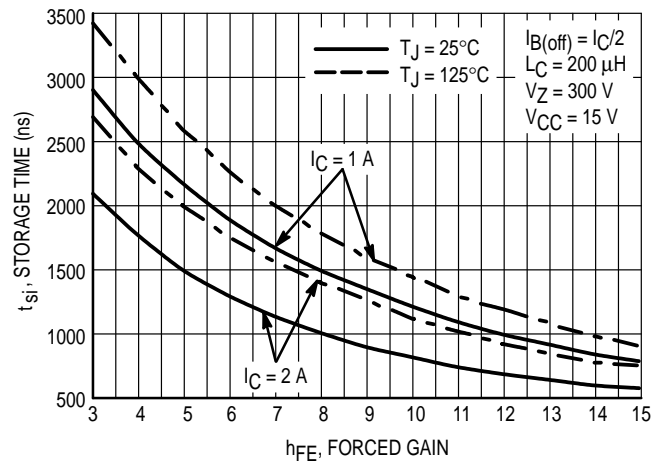

Figure 10. Inductive Storage Time, $t_{si}(h_{FE})$

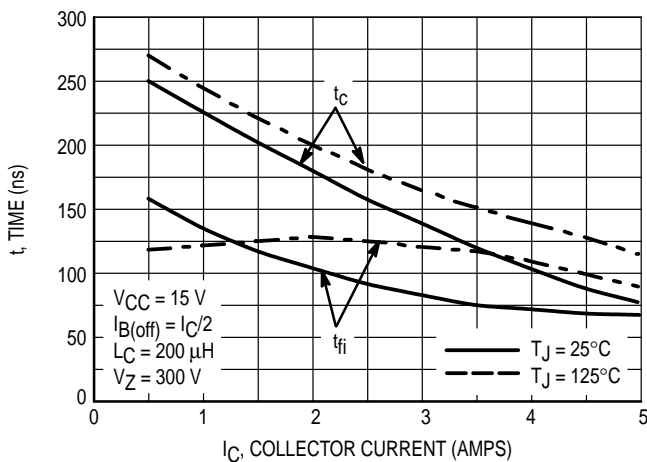

Figure 11. Inductive Switching, t_c & t_{fi} , $I_C/I_B = 5$

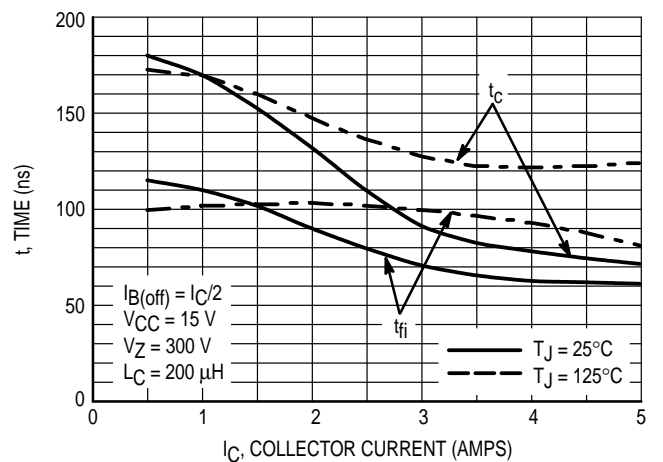

Figure 12. Inductive Switching, t_c & t_{fi} , $I_C/I_B = 10$

TYPICAL SWITCHING CHARACTERISTICS
($I_{B2} = I_C/2$ for all switching)

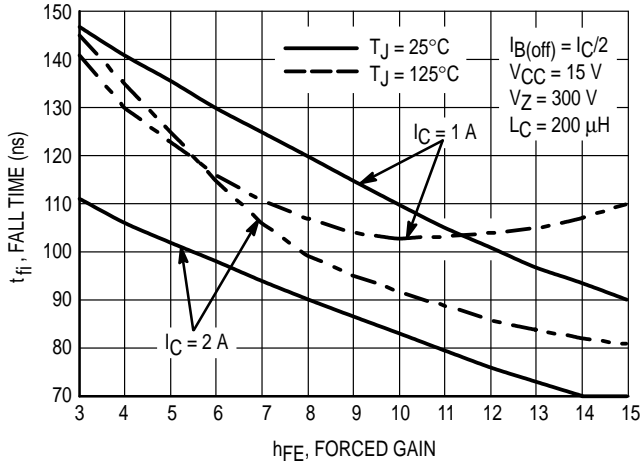

Figure 13. Inductive Fall Time, $t_{fi}(h_{FE})$

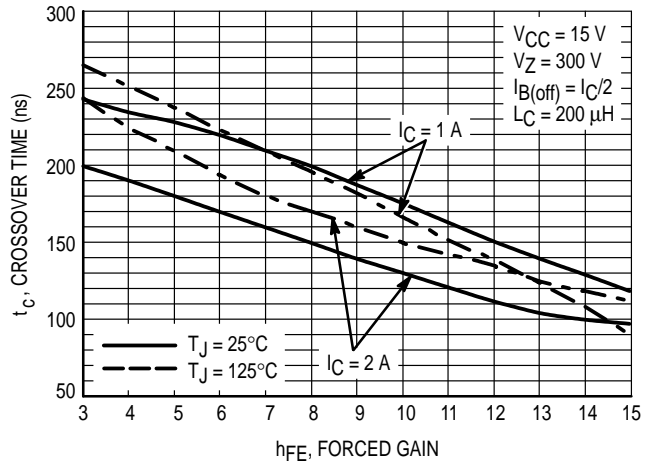

Figure 14. Crossover Time

GUARANTEED SAFE OPERATING AREA INFORMATION

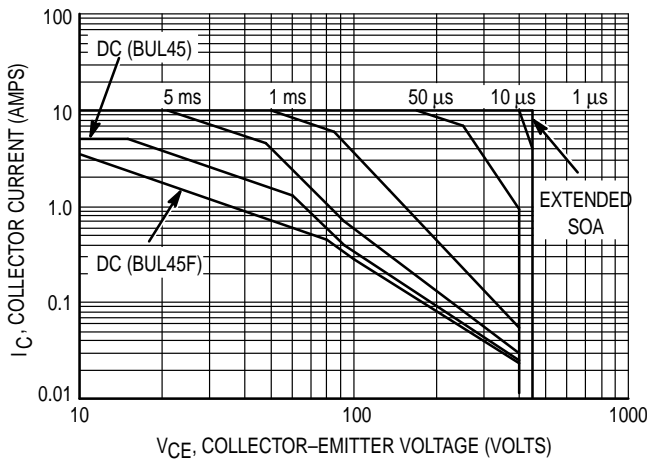

Figure 15. Forward Bias Safe Operating Area

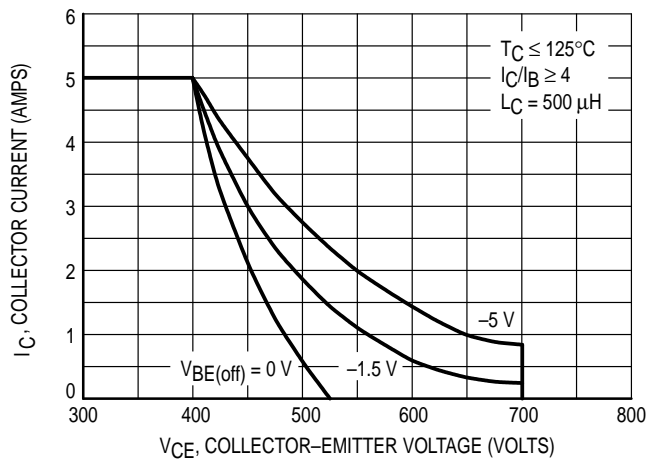

Figure 16. Reverse Bias Switching Safe Operating Area

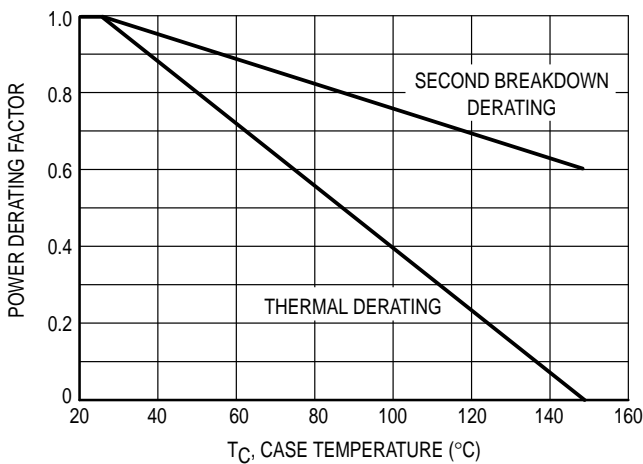

Figure 17. Forward Bias Power Derating

There are two limitations on the power handling ability of a transistor: average junction temperature and second breakdown. Safe operating area curves indicate $I_C - V_{CE}$ limits of the transistor that must be observed for reliable operation; i.e., the transistor must not be subjected to greater dissipation than the curves indicate. The data of Figure 15 is based on $T_C = 25^\circ\text{C}$; $T_{J(pk)}$ is variable depending on power level. Second breakdown pulse limits are valid for duty cycles to 10% but must be derated when $T_C \geq 25^\circ\text{C}$. Second breakdown limitations do not derate the same as thermal limitations. Allowable current at the voltages shown in Figure 15 may be found at any case temperature by using the appropriate curve on Figure 17. $T_{J(pk)}$ may be calculated from the data in Figures 20 and 21. At any case temperatures, thermal limitations will reduce the power that can be handled to values less than the limitations imposed by second breakdown. For inductive loads, high voltage and current must be sustained simultaneously during turn-off with the base-to-emitter junction reverse-biased. The safe level is specified as a reverse-biased safe operating area (Figure 16). This rating is verified under clamped conditions so that the device is never subjected to an avalanche mode.

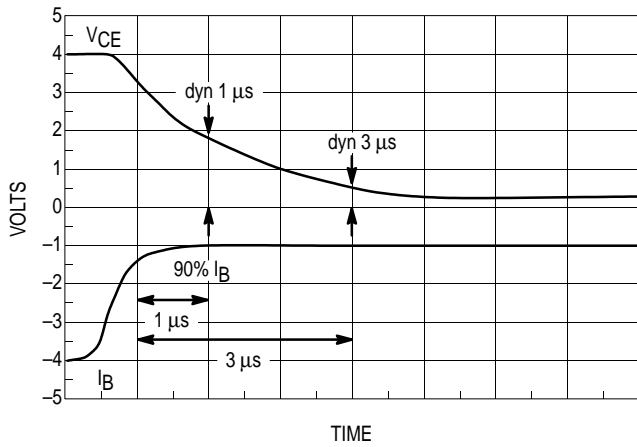

Figure 18. Dynamic Saturation Voltage Measurements

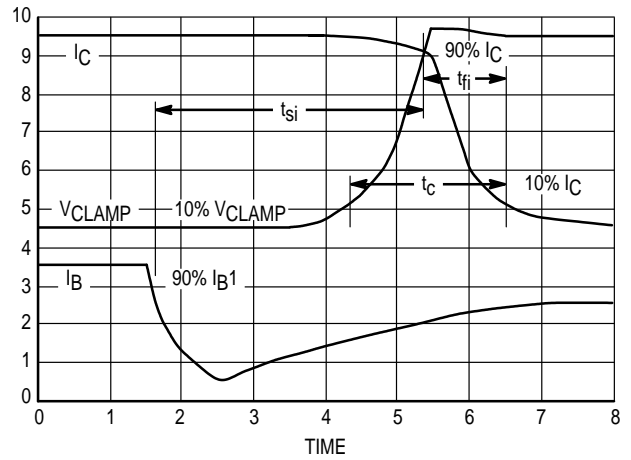
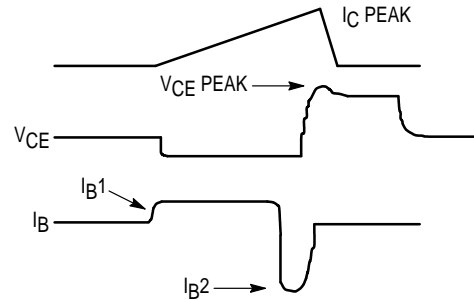
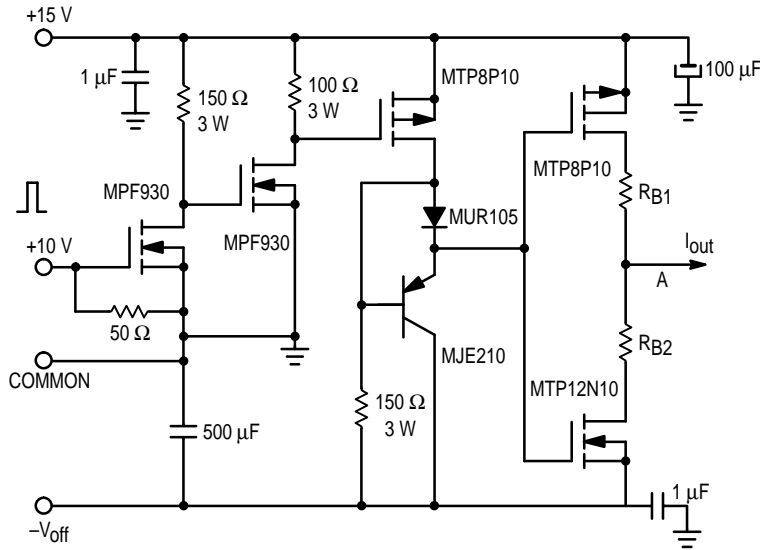

Figure 19. Inductive Switching Measurements



V(BR)CEO(sus)	INDUCTIVE SWITCHING	RBSOA
L = 10 mH	L = 200 μH	L = 500 μH
RB2 = ∞	RB2 = 0	RB2 = 0
VCC = 20 VOLTS	VCC = 15 VOLTS	VCC = 15 VOLTS
IC(pk) = 100 mA	RB1 SELECTED FOR DESIRED IB1	RB1 SELECTED FOR DESIRED IB1

Table 1. Inductive Load Switching Drive Circuit

TYPICAL THERMAL RESPONSE

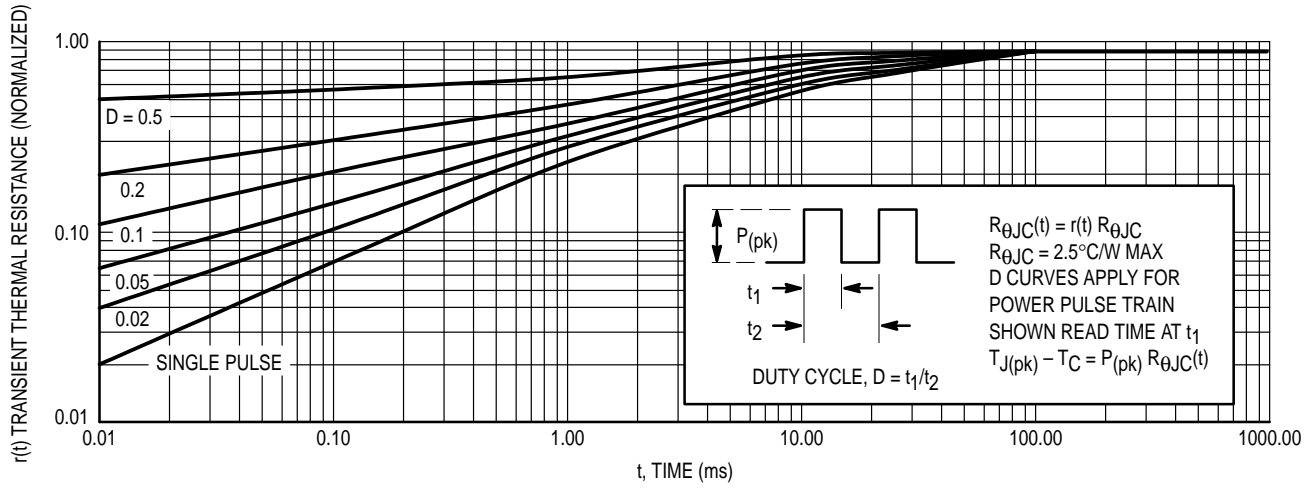

Figure 20. Typical Thermal Response ($Z_{\theta JC}(t)$) for BUL45

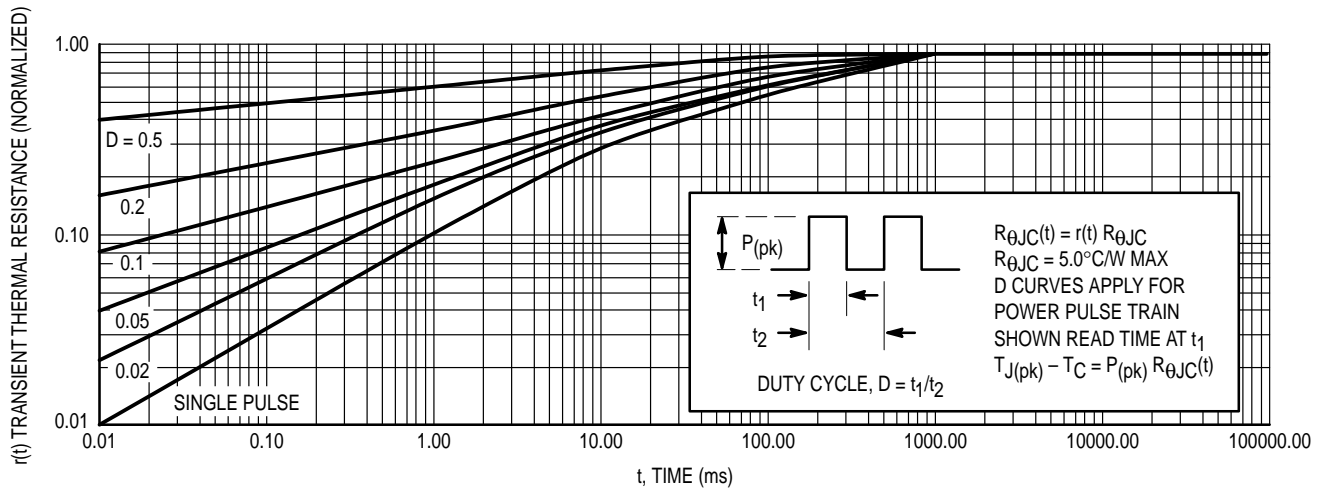
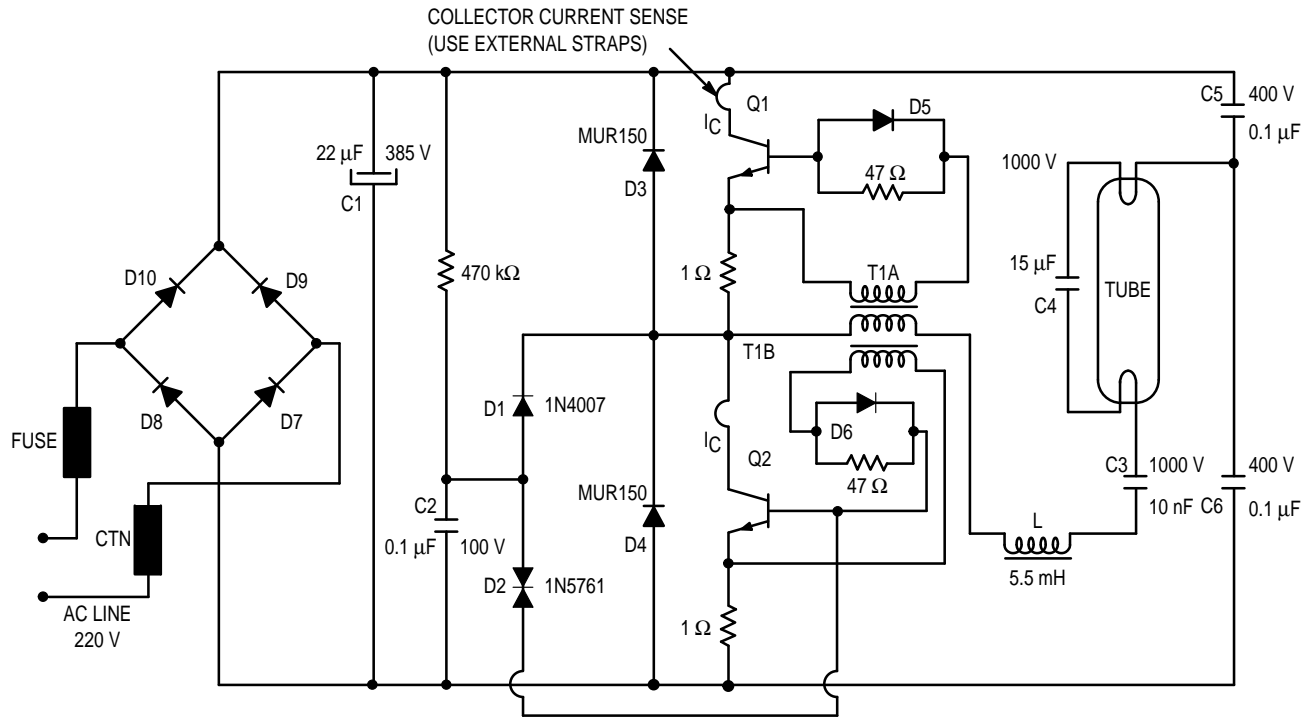

Figure 21. Typical Thermal Response ($Z_{\theta JC}(t)$) for BUL45F

BUL45 BUL45F

The BUL45/BUL45F Bipolar Power Transistors were specially designed for use in electronic lamp ballasts. A circuit designed by Motorola applications was built to

demonstrate how well these devices operate. The circuit and detailed component list are provided below.



Components Lists

Q1 = Q2 = BUL45 Transistor
 D1 = 1N4007 Rectifier
 D2 = 1N5761 Rectifier
 D3 = D4 = MUR150
 D5 = D6 = MUR105
 D7 = D8 = D9 = D10 = 1N400
 CTN = 47 Ω @ 25°C
 L = RM10 core, A1 = 400, B51 (LCC) 75 turns,
 wire \varnothing = 0.6 mm
 T1 = FT10 toroid, T4A (LCC)
 Primary: 4 turns
 Secondaries: T1A: 4 turns
 T1B: 4 turns

All resistors are 1/4 Watt, $\pm 5\%$
 R1 = 470 k Ω
 R2 = R3 = 47 Ω
 R4 = R5 = 1 Ω (these resistors are optional, and
 might be replaced by a short circuit)
 C1 = 22 μ F/385 V
 C2 = 0.1 μ F
 C3 = 10 nF/1000 V
 C4 = 15 μ F/1000 V
 C5 = C6 = 0.1 μ F/400 V

NOTES:

1. Since this design does not include the line input filter, it cannot be used "as-is" in a practical industrial circuit.
2. The windings are given for a 55 Watt load. For proper operation they must be re-calculated with any other loads.

Figure 22. Application Example

TEST CONDITIONS FOR ISOLATION TESTS*

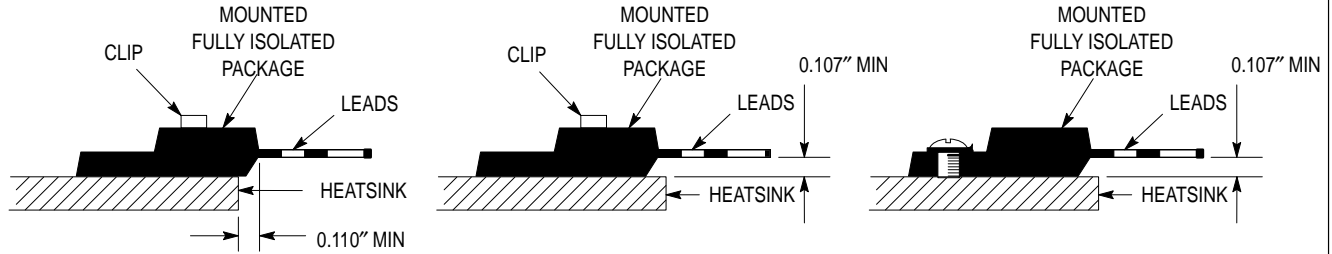

Figure 22a. Screw or Clip Mounting Position for Isolation Test Number 1

Figure 22b. Clip Mounting Position for Isolation Test Number 2

Figure 22c. Screw Mounting Position for Isolation Test Number 3

* Measurement made between leads and heatsink with all leads shorted together.

MOUNTING INFORMATION**

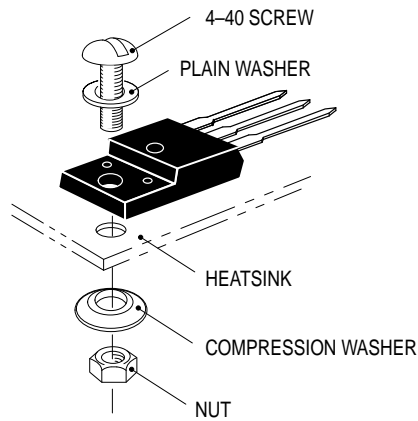

Figure 23a. Screw-Mounted

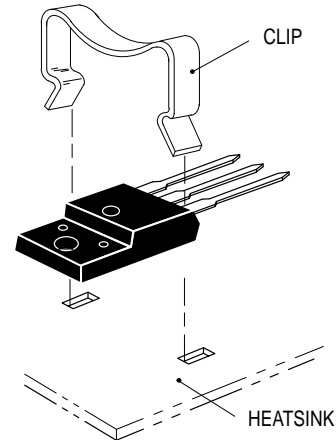

Figure 23b. Clip-Mounted

Figure 23. Typical Mounting Techniques for Isolated Package

Laboratory tests on a limited number of samples indicate, when using the screw and compression washer mounting technique, a screw torque of 6 to 8 in · lbs is sufficient to provide maximum power dissipation capability. The compression washer helps to maintain a constant pressure on the package over time and during large temperature excursions.

Destructive laboratory tests show that using a hex head 4-40 screw, without washers, and applying a torque in excess of 20 in · lbs will cause the plastic to crack around the mounting hole, resulting in a loss of isolation capability.

Additional tests on slotted 4-40 screws indicate that the screw slot fails between 15 to 20 in · lbs without adversely affecting the package. However, in order to positively ensure the package integrity of the fully isolated device, Motorola does not recommend exceeding 10 in · lbs of mounting torque under any mounting conditions.

** For more information about mounting power semiconductors see Application Note AN1040.

Motorola reserves the right to make changes without further notice to any products herein. Motorola makes no warranty, representation or guarantee regarding the suitability of its products for any particular purpose, nor does Motorola assume any liability arising out of the application or use of any product or circuit, and specifically disclaims any and all liability, including without limitation consequential or incidental damages. "Typical" parameters can and do vary in different applications. All operating parameters, including "Typicals" must be validated for each customer application by customer's technical experts. Motorola does not convey any license under its patent rights nor the rights of others. Motorola products are not designed, intended, or authorized for use as components in systems intended for surgical implant into the body, or other applications intended to support or sustain life, or for any other application in which the failure of the Motorola product could create a situation where personal injury or death may occur. Should Buyer purchase or use Motorola products for any such unintended or unauthorized application, Buyer shall indemnify and hold Motorola and its officers, employees, subsidiaries, affiliates, and distributors harmless against all claims, costs, damages, and expenses, and reasonable attorney fees arising out of, directly or indirectly, any claim of personal injury or death associated with such unintended or unauthorized use, even if such claim alleges that Motorola was negligent regarding the design or manufacture of the part. Motorola and are registered trademarks of Motorola, Inc. Motorola, Inc. is an Equal Opportunity/Affirmative Action Employer.

PACKAGE DIMENSIONS

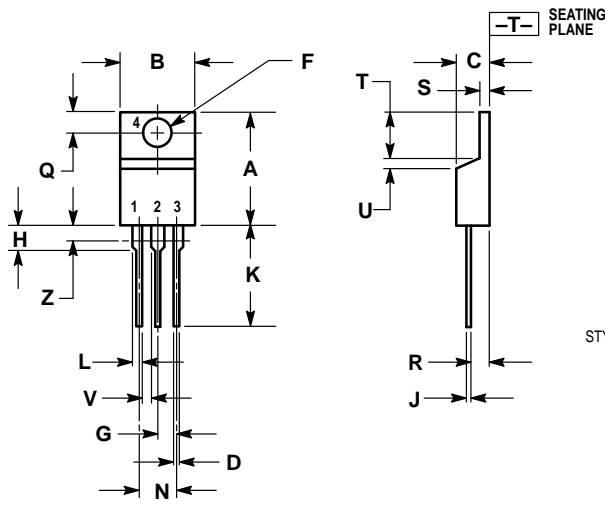

- NOTES:
1. DIMENSIONING AND TOLERANCING PER ANSI Y14.5M, 1982.
 2. CONTROLLING DIMENSION: INCH.
 3. DIMENSION Z DEFINES A ZONE WHERE ALL BODY AND LEAD IRREGULARITIES ARE ALLOWED.

DIM	INCHES		MILLIMETERS	
	MIN	MAX	MIN	MAX
A	0.570	0.620	14.48	15.75
B	0.380	0.405	9.66	10.28
C	0.160	0.190	4.07	4.82
D	0.025	0.035	0.64	0.88
F	0.142	0.147	3.61	3.73
G	0.095	0.105	2.42	2.66
H	0.110	0.155	2.80	3.93
J	0.018	0.025	0.46	0.64
K	0.500	0.562	12.70	14.27
L	0.045	0.060	1.15	1.52
N	0.190	0.210	4.83	5.33
Q	0.100	0.120	2.54	3.04
R	0.080	0.110	2.04	2.79
S	0.045	0.055	1.15	1.39
T	0.235	0.255	5.97	6.47
U	0.000	0.050	0.00	1.27
V	0.045	—	1.15	—
Z	—	0.080	—	2.04

- STYLE 1:
1. BASE
 2. COLLECTOR
 3. EMITTER
 4. COLLECTOR

**BUL45
CASE 221A-06
TO-220AB
ISSUE Y**

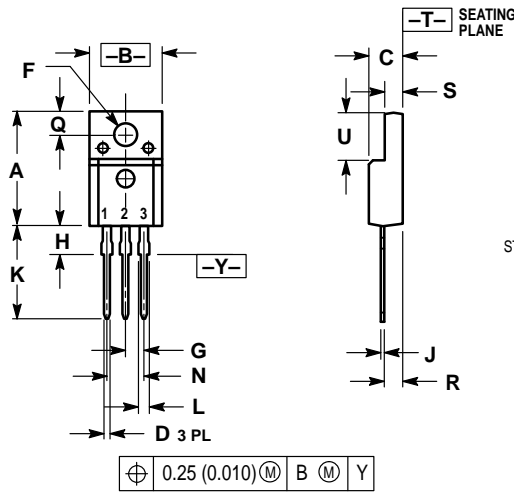

- NOTES:
1. DIMENSIONING AND TOLERANCING PER ANSI Y14.5M, 1982.
 2. CONTROLLING DIMENSION: INCH.

DIM	INCHES		MILLIMETERS	
	MIN	MAX	MIN	MAX
A	0.621	0.629	15.78	15.97
B	0.394	0.402	10.01	10.21
C	0.181	0.189	4.60	4.80
D	0.026	0.034	0.67	0.86
F	0.121	0.129	3.08	3.27
G	0.100 BSC	—	2.54 BSC	—
H	0.123	0.129	3.13	3.27
J	0.018	0.025	0.46	0.64
K	0.500	0.562	12.70	14.27
L	0.045	0.060	1.14	1.52
N	0.200 BSC	—	5.08 BSC	—
Q	0.126	0.134	3.21	3.40
R	0.107	0.111	2.72	2.81
S	0.096	0.104	2.44	2.64
U	0.259	0.267	6.58	6.78

- STYLE 2:
1. BASE
 2. COLLECTOR
 3. EMITTER

⊕ 0.25 (0.010) M B M Y

**BUL45F
CASE 221D-02
(ISOLATED TO-220 TYPE)
ISSUE D**

How to reach us:
USA / EUROPE: Motorola Literature Distribution;
 P.O. Box 20912; Phoenix, Arizona 85036. 1-800-441-2447

JAPAN: Nippon Motorola Ltd.; Tatsumi-SPD-JLDC, Toshikatsu Otsuki,
 6F Seibu-Butsuryu-Center, 3-14-2 Tatsumi Koto-Ku, Tokyo 135, Japan. 03-3521-8315

MFAX: RMFAX0@email.sps.mot.com - TOUCHTONE (602) 244-6609
INTERNET: http://Design-NET.com

HONG KONG: Motorola Semiconductors H.K. Ltd.; 8B Tai Ping Industrial Park,
 51 Ting Kok Road, Tai Po, N.T., Hong Kong. 852-26629298



This datasheet has been downloaded from:

www.DatasheetCatalog.com

Datasheets for electronic components.



LittleDiode supplies new, hard to find or obsolete electronic components and semiconductors all over the world.

With over two million different components listed you are sure to find the part you need.

Feel free to visit us today at our online store:

LittleDiode.com

Looking forward to providing you with the best possible service.