

BULD25D, BULD25DR, BULD25SL NPN SILICON TRANSISTOR WITH INTEGRATED DIODE

Copyright © 1997, Power Innovations Limited, UK

JULY 1994 - REVISED SEPTEMBER 1997

- **Designed Specifically for High Frequency Electronic Ballasts**
- **Integrated Fast t_{rr} Anti-parallel Diode, Enhancing Reliability**
- **Diode t_{rr} Typically 500 ns**
- **New Ultra Low-Height SOIC Power Package**
- **Tightly Controlled Transistor Storage Times**
- **Voltage Matched Integrated Transistor and Diode**
- **Characteristics Optimised for Cool Running**
- **Diode-Transistor Charge Coupling Minimised to Enhance Frequency Stability**
- **Custom Switching Selections Available**
- **Surface Mount and Through-Hole Options**

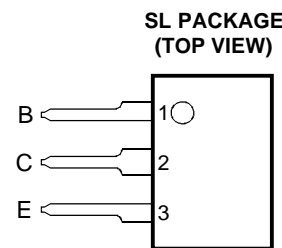
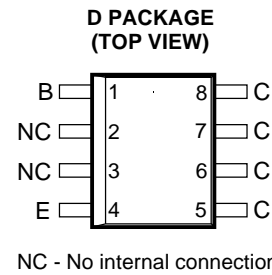

PACKAGE	PART # SUFFIX
Small-outline	D
Small-outline taped and reeled	DR
Single-in-line	SL

device symbol

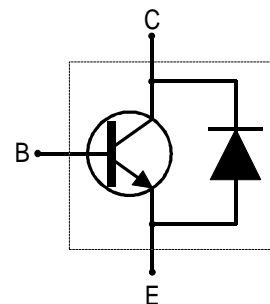

description

The new BULDxx range of transistors have been designed specifically for use in High Frequency Electronic Ballasts (HFEB's). This range of switching transistors has tightly controlled storage times and an integrated fast t_{rr} anti-parallel diode. The revolutionary design ensures that the diode has both fast forward and reverse recovery times, achieving the same performance as a discrete anti-parallel diode plus transistor.

The integrated diode has minimal charge coupling with the transistor, increasing frequency stability, especially in lower power circuits where the circulating currents are low. By design, this new device offers a voltage matched integrated transistor and anti-parallel diode.

This device is available in the now well established 8 pin low height surface mount D package, and the TO-220 pin compatible SL package. Use of the SL package allows for a 40% height saving, making it ideal for compact ballast applications.

absolute maximum ratings at 25°C ambient temperature (unless otherwise noted)

RATING	SYMBOL	VALUE	UNIT
Collector-emitter voltage ($V_{BE} = 0$)	V_{CES}	600	V
Collector-base voltage ($I_E = 0$)	V_{CBO}	600	V
Collector-emitter voltage ($I_B = 0$)	V_{CEO}	400	V
Emitter-base voltage	V_{EBO}	9	V

PRODUCT INFORMATION

Information is current as of publication date. Products conform to specifications in accordance with the terms of Power Innovations standard warranty. Production processing does not necessarily include testing of all parameters.



BULD25D, BULD25DR, BULD25SL

NPN SILICON TRANSISTOR WITH INTEGRATED DIODE

JULY 1994 - REVISED SEPTEMBER 1997

absolute maximum ratings at 25°C ambient temperature (unless otherwise noted) (continued)

RATING		SYMBOL	VALUE	UNIT
Continuous collector current (see Note 1)		I_C	2	A
Peak collector current (see Note 2)		I_{CM}	4	A
Continuous base current (see Note 1)		I_B	1.5	A
Peak base current (see Note 2)		I_{BM}	2.5	A
Continuous device dissipation at (or below) 25°C ambient temperature	BULD25D BULD25SL	P_{tot}	see Figure 10 see Figure 11	W
Maximum average continuous diode forward current at (or below) 25°C ambient temperature		$I_{E(av)}$	0.5	A
Operating junction temperature range		T_j	-65 to +150	°C
Storage temperature range		T_{stg}	-65 to +150	°C

- NOTES: 1. This value applies for $t_p = 1$ s.
2. This value applies for $t_p = 10$ ms, duty cycle $\leq 2\%$.

electrical characteristics at 25°C ambient temperature

PARAMETER	TEST CONDITIONS		MIN	TYP	MAX	UNIT
$V_{CEO(sus)}$ Collector-emitter sustaining voltage	$I_C = 0.1$ A		400			V
I_{CES} Collector-emitter cut-off current	$V_{CE} = 600$ V	$V_{BE} = 0$			10	μ A
I_{EBO} Emitter cut-off current	$V_{EB} = 9$ V	$I_C = 0$			1	mA
$V_{BE(sat)}$ Base-emitter saturation voltage	$I_B = 0.1$ A	$I_C = 0.5$ A (see Notes 3 and 4)		0.9	1.1	V
$V_{CE(sat)}$ Collector-emitter saturation voltage	$I_B = 0.1$ A $I_B = 0.2$ A	$I_C = 0.5$ A $I_C = 1$ A (see Notes 3 and 4)		0.3 0.6	0.5 1	V
h_{FE} Forward current transfer ratio	$V_{CE} = 10$ V $V_{CE} = 1.5$ V $V_{CE} = 5$ V	$I_C = 0.01$ A $I_C = 0.5$ A $I_C = 1$ A (see Notes 3 and 4)	10 10 10	18 15 15	20 20	
V_{EC} Anti-parallel diode forward voltage	$I_E = 1$ A	(see Notes 3 and 4)		1.5	1.7	V

- NOTES: 3. These parameters must be measured using pulse techniques, $t_p = 300$ μ s, duty cycle $\leq 2\%$.
4. These parameters must be measured using voltage-sensing contacts, separate from the current carrying contacts, and located within 1 mm from the device body for the D package and 3.2 mm from the device body for the SL package.

thermal characteristics

PARAMETER		MIN	TYP	MAX	UNIT
$R_{\theta JA}$ Junction to free air thermal resistance	D package SL Package			165 115	°C/W

switching characteristics at 25°C ambient temperature

PARAMETER	TEST CONDITIONS		MIN	TYP	MAX	UNIT
t_{rr} Anti-parallel diode reverse recovery time	Measured by holding transistor in an off condition, $V_{EB} = -3$ V (see Note 5)			0.5	1	μ s
t_s Storage time	(see Note 5)		2	3.5	5	μ s
t_f Fall time	(see Note 5)			0.25	0.35	μ s

NOTE 5: Refer to Figures 12, 13 and 14 for Functional Test Circuit and Switching Waveforms.

PRODUCT INFORMATION

TYPICAL CHARACTERISTICS

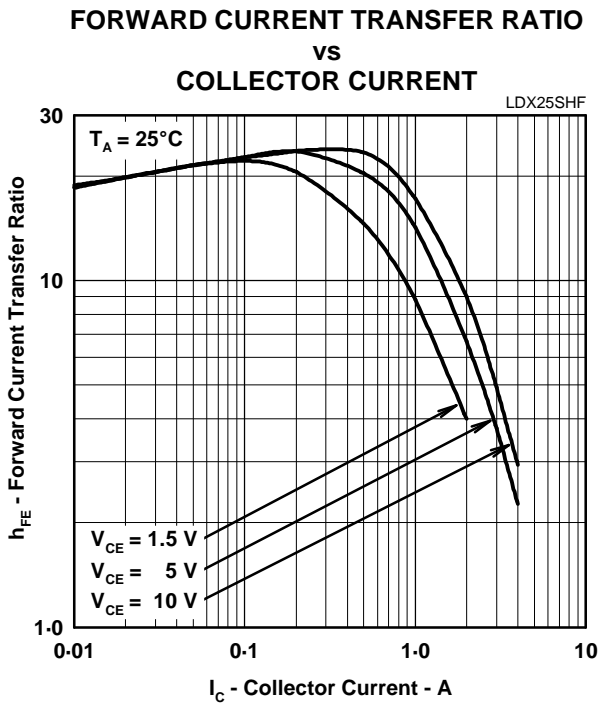

Figure 1.

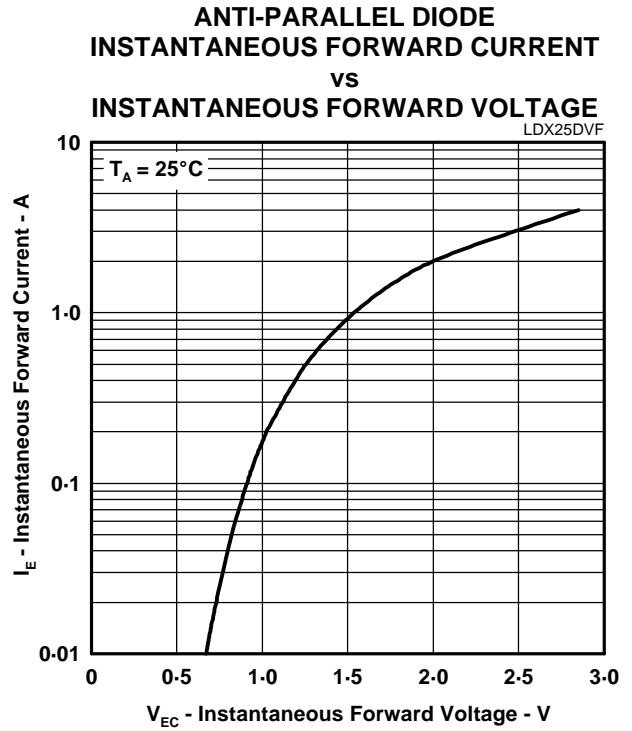

Figure 2.

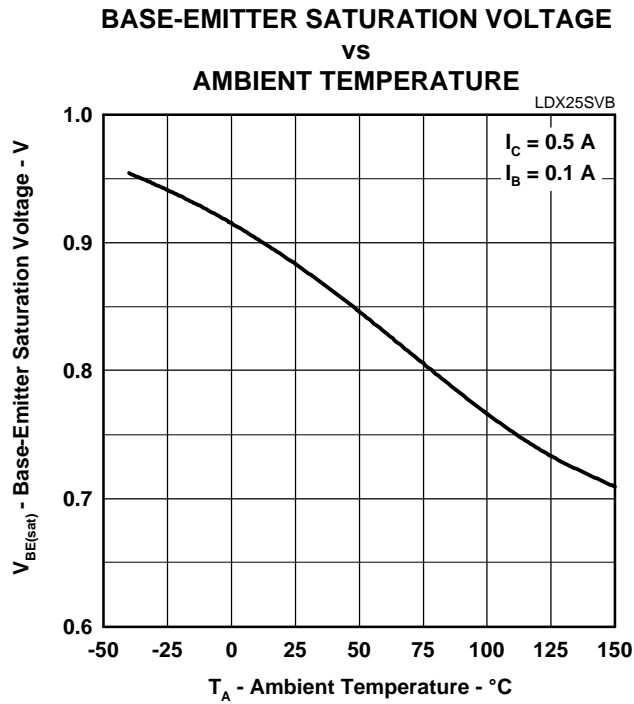

Figure 3.

BULD25D, BULD25DR, BULD25SL NPN SILICON TRANSISTOR WITH INTEGRATED DIODE

JULY 1994 - REVISED SEPTEMBER 1997

MAXIMUM SAFE OPERATING REGIONS

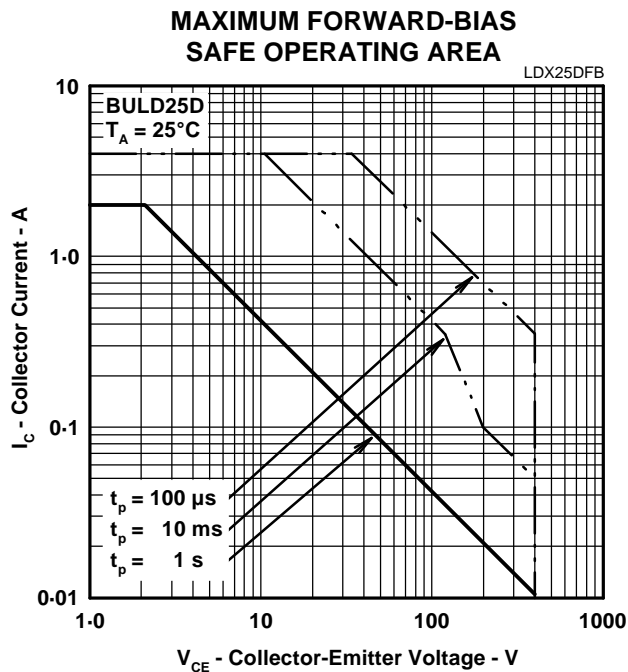

Figure 4.

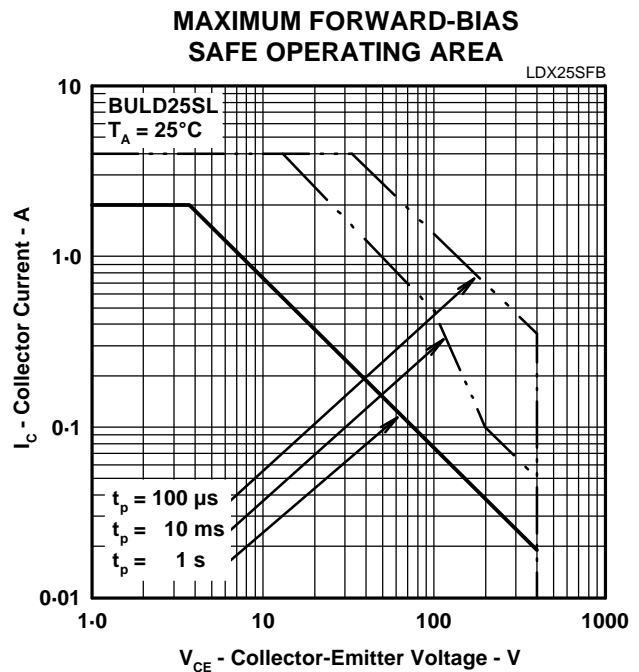

Figure 5.

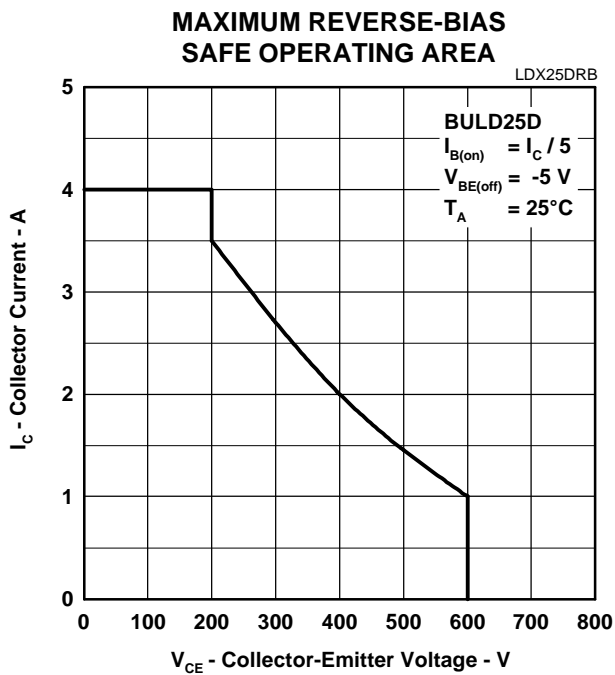

Figure 6.

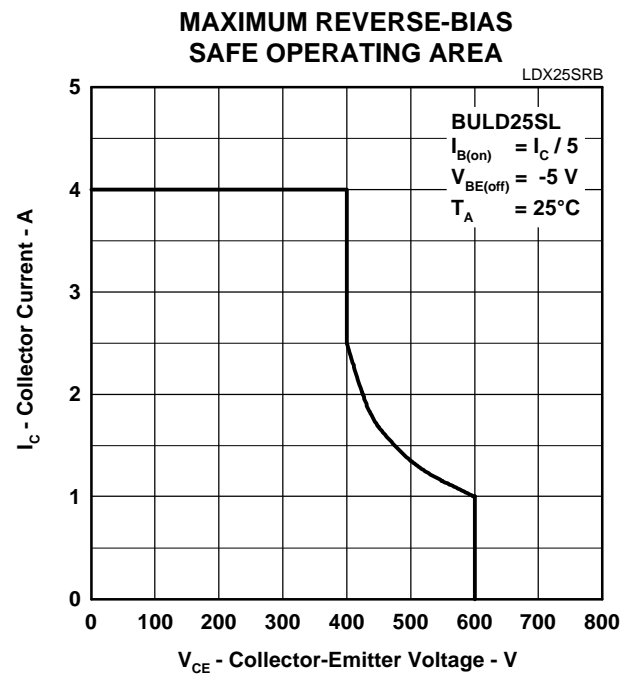

Figure 7.

THERMAL INFORMATION

THERMAL RESPONSE JUNCTION TO AMBIENT
VS
POWER PULSE DURATION

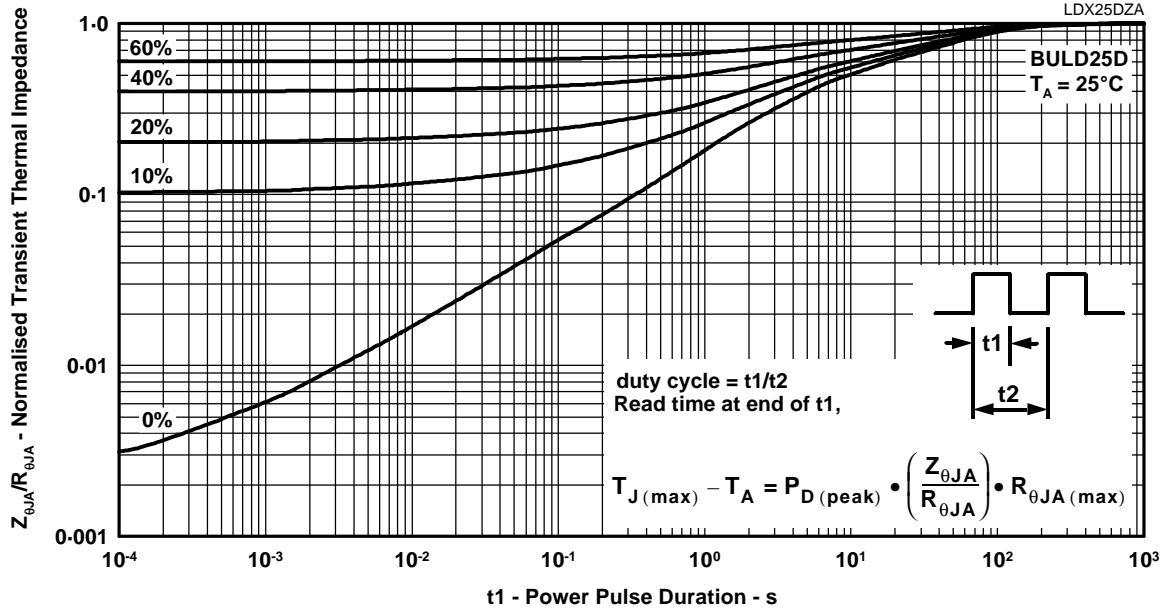

Figure 8.

THERMAL RESPONSE JUNCTION TO AMBIENT
VS
POWER PULSE DURATION

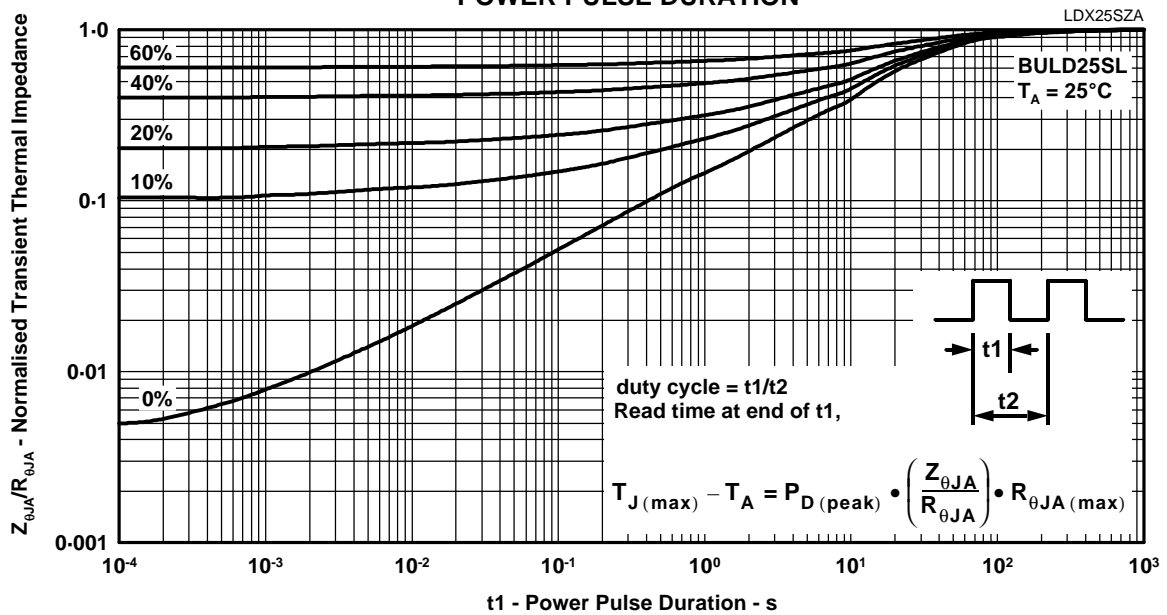

Figure 9.

BULD25D, BULD25DR, BULD25SL NPN SILICON TRANSISTOR WITH INTEGRATED DIODE

JULY 1994 - REVISED SEPTEMBER 1997

THERMAL INFORMATION

MAXIMUM POWER DISSIPATION JUNCTION TO AMBIENT VS POWER PULSE DURATION

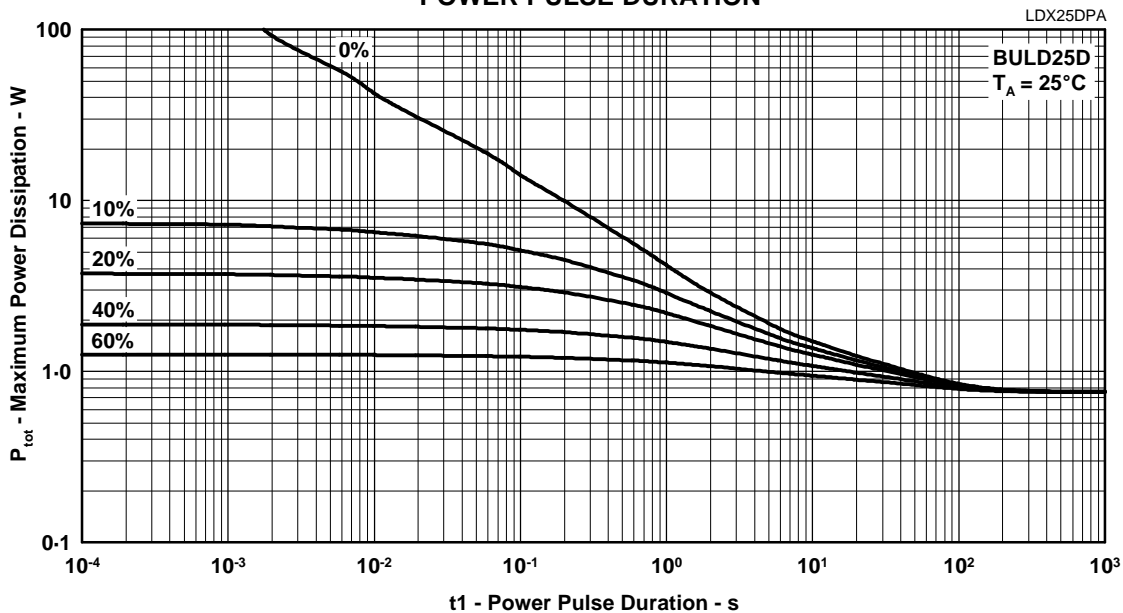

Figure 10.

MAXIMUM POWER DISSIPATION JUNCTION TO AMBIENT VS POWER PULSE DURATION

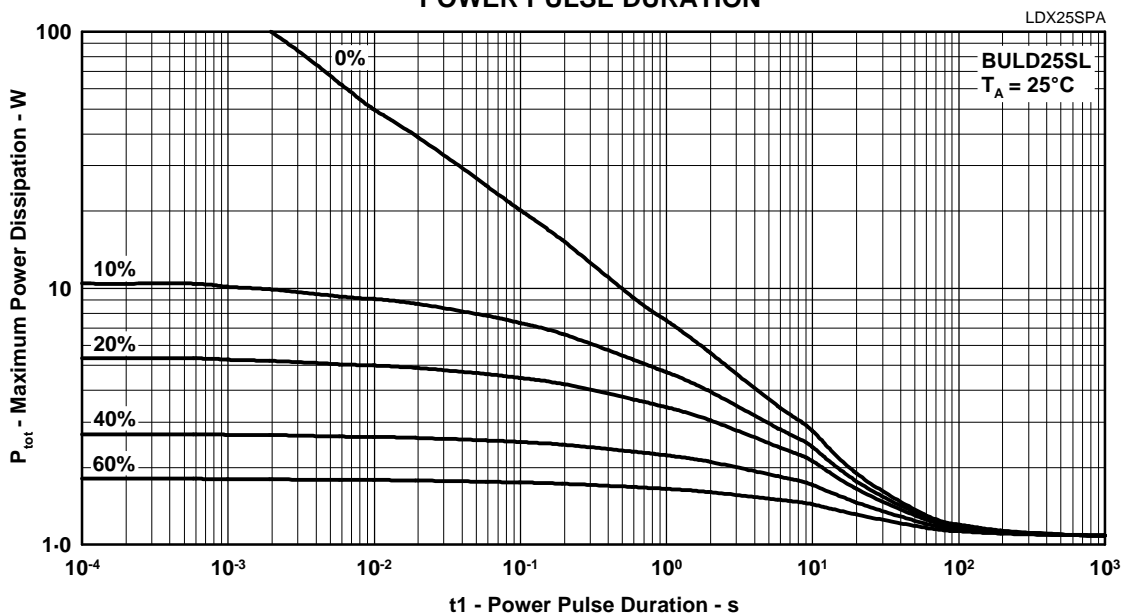

Figure 11.

FUNCTIONAL TEST CIRCUIT

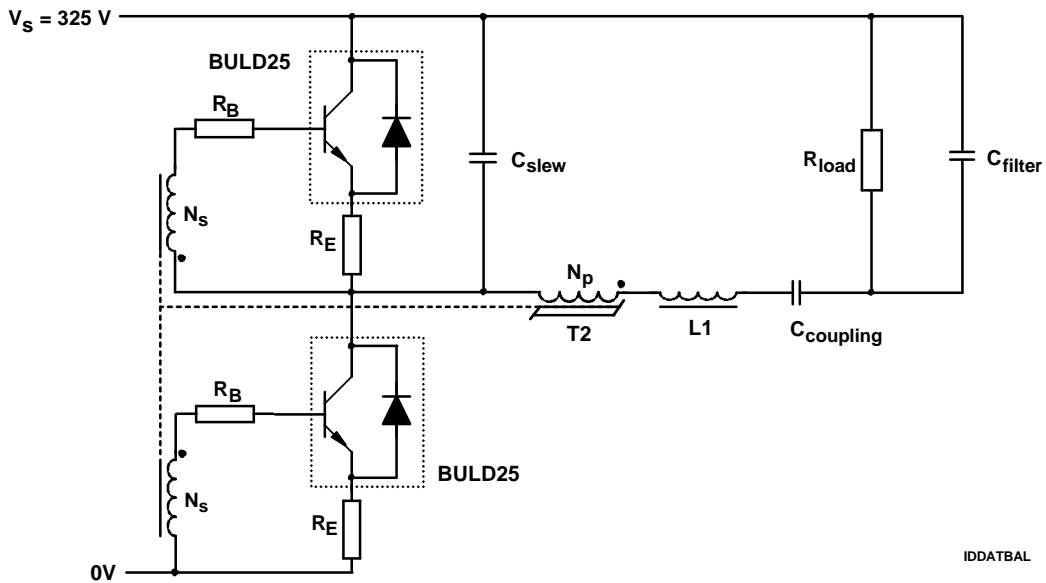

Figure 12.

COMPONENT VALUES USED IN FUNCTIONAL TEST CIRCUIT	
R_B	22 Ω
R_E	1.8 Ω
R_{load}	470 Ω
$C_{coupling}$	47 nF
C_{slew}	1.5 nF
C_{filter}	3.2 nF
L1	2.5 mH
T2 $N_p : N_s$	5 : 3

Figure 13.

BULD25D, BULD25DR, BULD25SL NPN SILICON TRANSISTOR WITH INTEGRATED DIODE

JULY 1994 - REVISED SEPTEMBER 1997

FUNCTIONAL TEST SWITCHING WAVEFORMS

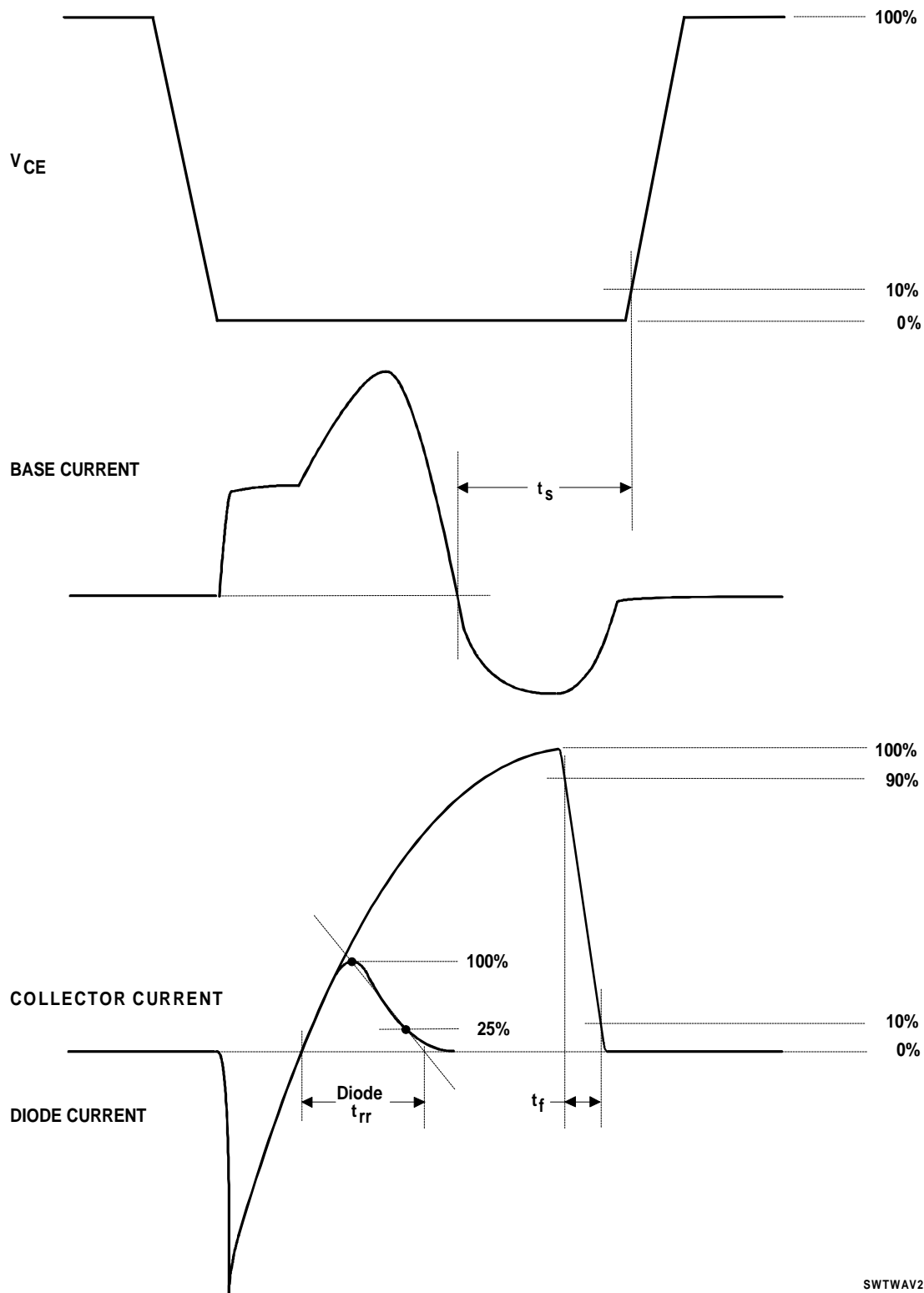

Figure 14. Switching Waveforms of device in Functional Test Circuit

BULD25D, BULD25DR, BULD25SL NPN SILICON TRANSISTOR WITH INTEGRATED DIODE

JULY 1994 - REVISED SEPTEMBER 1997

MECHANICAL DATA

D008

plastic small-outline package

This small-outline package consists of a circuit mounted on a lead frame and encapsulated within a plastic compound. The compound will withstand soldering temperature with no deformation, and circuit performance characteristics will remain stable when operated in high humidity conditions. Leads require no additional cleaning or processing when used in soldered assembly.

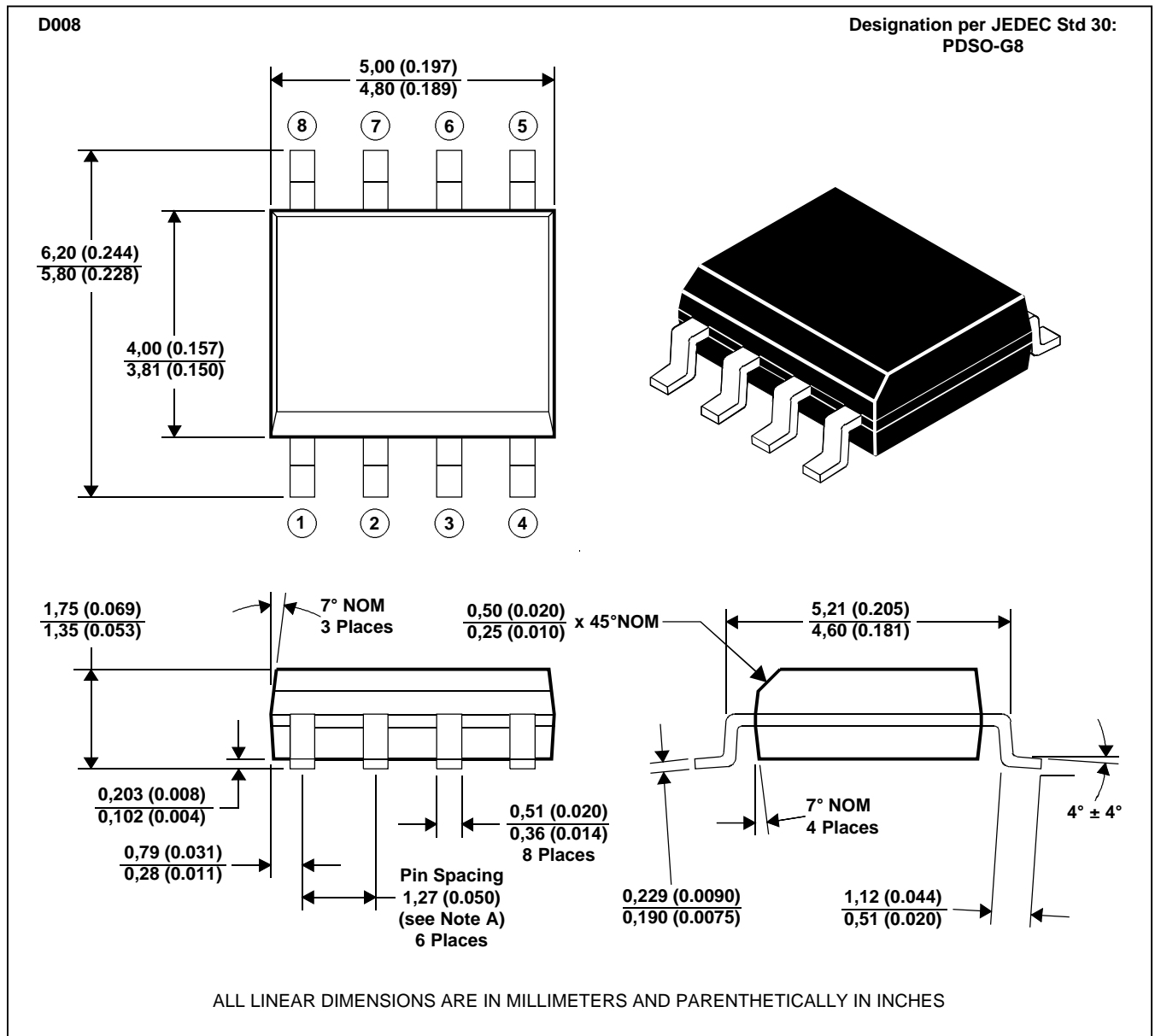

- NOTES: A. Leads are within 0,25 (0.010) radius of true position at maximum material condition.
B. Body dimensions do not include mold flash or protrusion.
C. Mold flash or protrusion shall not exceed 0,15 (0.006).
D. Lead tips to be planar within ±0,051 (0.002).

MDXXAA

BULD25D, BULD25DR, BULD25SL NPN SILICON TRANSISTOR WITH INTEGRATED DIODE

JULY 1994 - REVISED SEPTEMBER 1997

MECHANICAL DATA

SL003

3-pin plastic single-in-line package

This single-in-line package consists of a circuit mounted on a lead frame and encapsulated within a plastic compound. The compound will withstand soldering temperature with no deformation, and circuit performance characteristics will remain stable when operated in high humidity conditions. Leads require no additional cleaning or processing when used in soldered assembly.

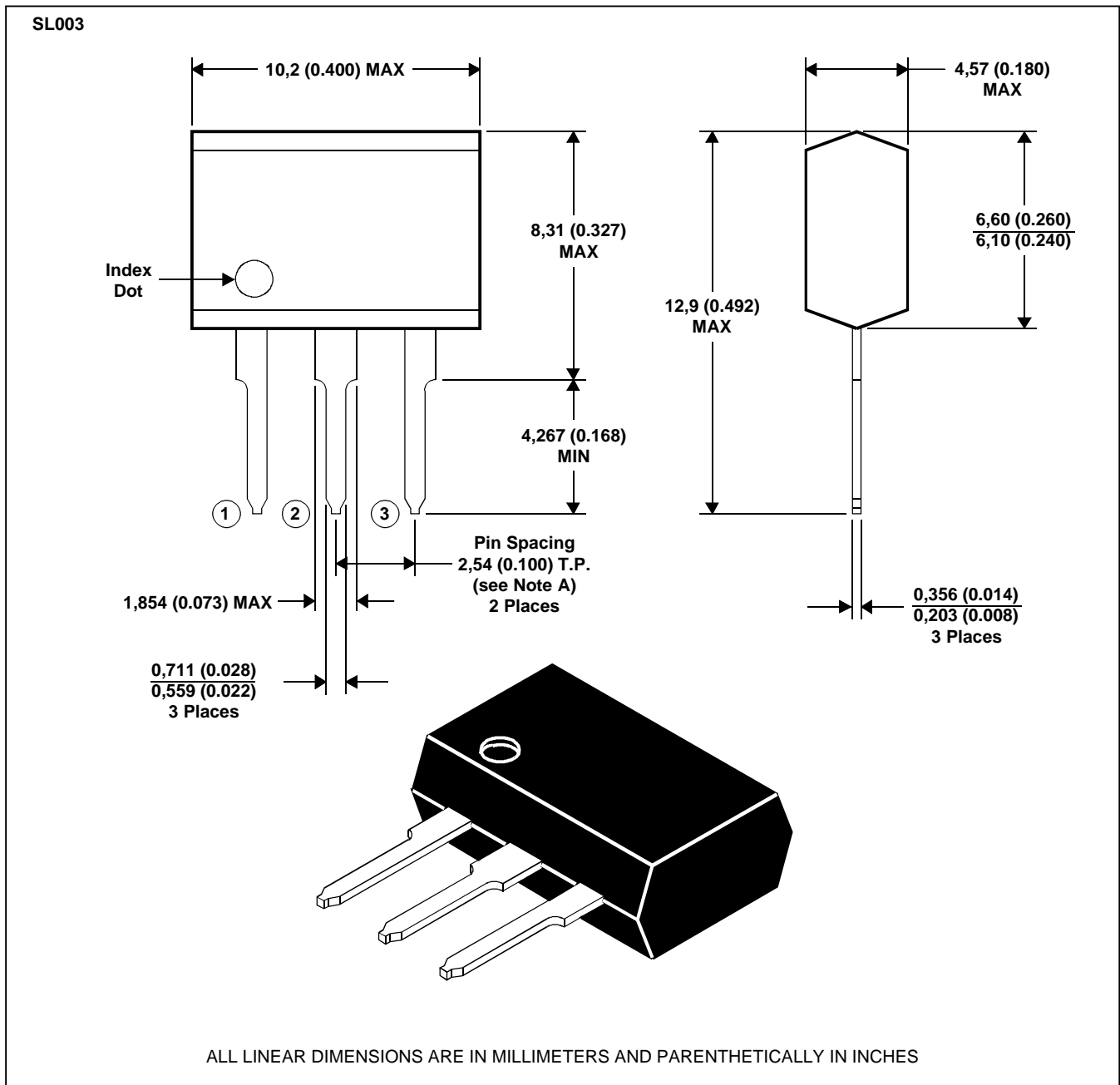

NOTES: A. Each pin centerline is located within 0,25 (0.010) of its true longitudinal position.
B. Body molding flash of up to 0,15 (0.006) may occur in the package lead plane.

MDXXAD

PRODUCT INFORMATION

BULD25D, BULD25DR, BULD25SL

NPN SILICON TRANSISTOR WITH INTEGRATED DIODE

JULY 1994 - REVISED SEPTEMBER 1997

IMPORTANT NOTICE

Power Innovations Limited (PI) reserves the right to make changes to its products or to discontinue any semiconductor product or service without notice, and advises its customers to verify, before placing orders, that the information being relied on is current.

PI warrants performance of its semiconductor products to the specifications applicable at the time of sale in accordance with PI's standard warranty. Testing and other quality control techniques are utilized to the extent PI deems necessary to support this warranty. Specific testing of all parameters of each device is not necessarily performed, except as mandated by government requirements.

PI accepts no liability for applications assistance, customer product design, software performance, or infringement of patents or services described herein. Nor is any license, either express or implied, granted under any patent right, copyright, design right, or other intellectual property right of PI covering or relating to any combination, machine, or process in which such semiconductor products or services might be or are used.

PI SEMICONDUCTOR PRODUCTS ARE NOT DESIGNED, INTENDED, AUTHORIZED, OR WARRANTED TO BE SUITABLE FOR USE IN LIFE-SUPPORT APPLICATIONS, DEVICES OR SYSTEMS.

Copyright © 1997, Power Innovations Limited

PRODUCT INFORMATION



LittleDiode supplies new, hard to find or obsolete electronic components and semiconductors all over the world.

With over two million different components listed you are sure to find the part you need.

Feel free to visit us today at our online store:

LittleDiode.com

Looking forward to providing you with the best possible service.