

DATA SHEET

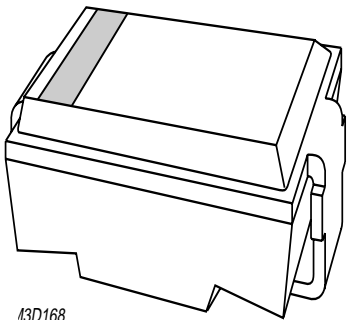

13D168

BYG50 series Controlled avalanche rectifiers

Preliminary specification

1996 May 24

Controlled avalanche rectifiers

BYG50 series

FEATURES

- Glass passivated
- High maximum operating temperature
- Low leakage current
- Excellent stability
- Guaranteed avalanche energy absorption capability
- UL 94V-O classified plastic package
- Shipped in 12 mm embossed tape.

DESCRIPTION

DO-214AC; SOD106 surface mountable package with glass passivated chip.

The well-defined void-free case is of a transfer-moulded thermo-setting plastic.

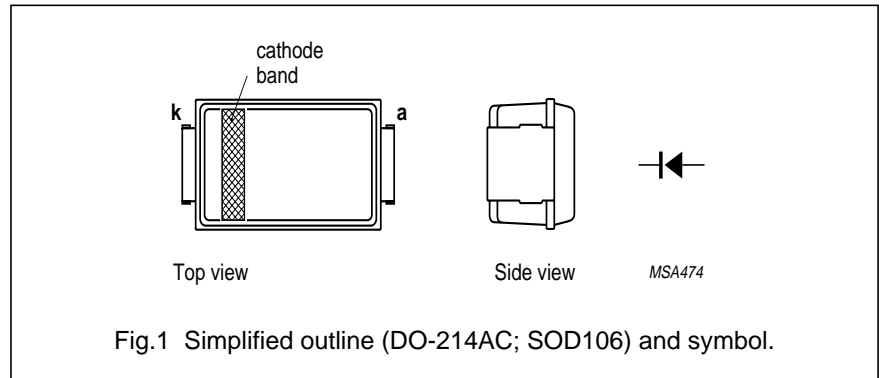

LIMITING VALUES

In accordance with the Absolute Maximum Rating System (IEC 134).

SYMBOL	PARAMETER	CONDITIONS	MIN.	MAX.	UNIT
V _{RRM}	repetitive peak reverse voltage				
	BYG50D		–	200	V
	BYG50G		–	400	V
	BYG50J		–	600	V
	BYG50K		–	800	V
	BYG50M		–	1000	V
V _R	continuous reverse voltage				
	BYG50D		–	200	V
	BYG50G		–	400	V
	BYG50J		–	600	V
	BYG50K		–	800	V
	BYG50M		–	1000	V
I _{F(AV)}	average forward current	averaged over any 20 ms period; T _{tp} = 100 °C; see Fig.2	–	2.1	A
		averaged over any 20 ms period; Al ₂ O ₃ PCB mounting (see Fig.7); T _{amb} = 60 °C; see Fig.3	–	1.0	A
		averaged over any 20 ms period; epoxy PCB mounting (see Fig.7); T _{amb} = 60 °C; see Fig.3	–	0.7	A
I _{FSM}	non-repetitive peak forward current	t = 10 ms half sinewave; T _j = T _{j max} prior to surge; V _R = V _{RRMmax}	–	30	A

Controlled avalanche rectifiers

BYG50 series

SYMBOL	PARAMETER	CONDITIONS	MIN.	MAX.	UNIT
E_{RSM}	non-repetitive peak reverse avalanche energy	$L = 120 \text{ mH}$; $T_j = T_{j \text{ max}}$ prior to surge; inductive load switched off			
	BYG50D to J		–	10	mJ
	BYG50K and M		–	7	mJ
T_{stg}	storage temperature		–65	+175	°C
T_j	junction temperature	see Fig.4	–65	+175	°C

ELECTRICAL CHARACTERISTICS

$T_j = 25 \text{ °C}$; unless otherwise specified.

SYMBOL	PARAMETER	CONDITIONS	MIN.	TYP.	MAX.	UNIT	
V_F	forward voltage	$I_F = 1 \text{ A}$; $T_j = T_{j \text{ max}}$; see Fig.5	–	–	0.85	V	
		$I_F = 1 \text{ A}$; see Fig.5	–	–	1.00	V	
$V_{(BR)R}$	reverse avalanche breakdown voltage	$I_R = 0.1 \text{ mA}$					
			BYG50D	300	–	–	V
			BYG50G	500	–	–	V
			BYG50J	700	–	–	V
			BYG50K	900	–	–	V
	BYG50M	1100	–	–	V		
I_R	reverse current	$V_R = V_{RRM \text{ max}}$; see Fig.6	–	–	1	μA	
		$V_R = V_{RRM \text{ max}}$; $T_j = 165 \text{ °C}$; see Fig.6	–	–	100	μA	
t_{rr}	reverse recovery time	when switched from $I_F = 0.5 \text{ A}$ to $I_R = 1 \text{ A}$; measured at $I_R = 0.25 \text{ A}$; see Fig.8	–	2	–	μs	

THERMAL CHARACTERISTICS

SYMBOL	PARAMETER	CONDITIONS	VALUE	UNIT
$R_{th \text{ j-tp}}$	thermal resistance from junction to tie-point		25	K/W
$R_{th \text{ j-a}}$	thermal resistance from junction to ambient	note 1	100	K/W
		note 2	150	K/W

Notes

1. Device mounted on Al_2O_3 printed-circuit board, 0.7 mm thick; thickness of copper $\geq 35 \mu\text{m}$, see Fig.7.
2. Device mounted on epoxy-glass printed-circuit board, 1.5 mm thick; thickness of copper $\geq 40 \mu\text{m}$, see Fig.7.
For more information please refer to the "General Part of associated Handbook".

Controlled avalanche rectifiers

BYG50 series

GRAPHICAL DATA

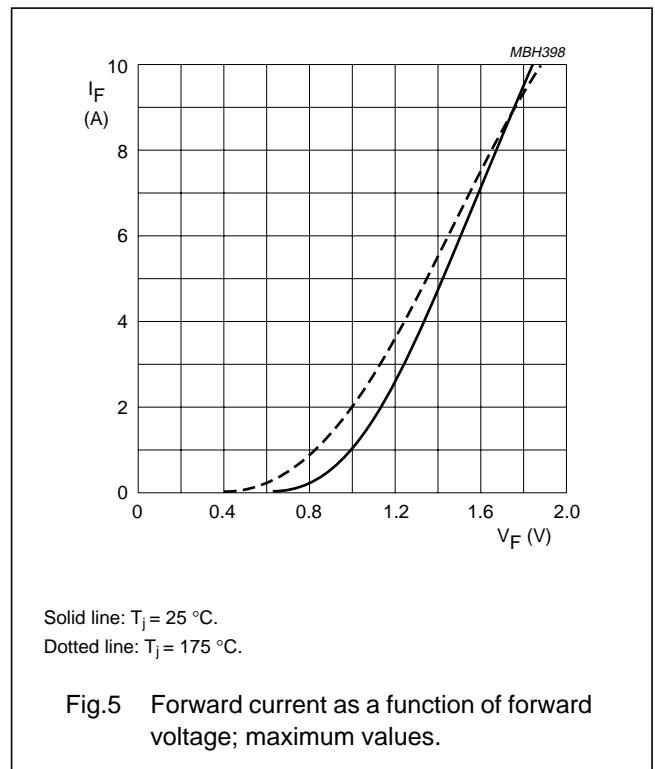
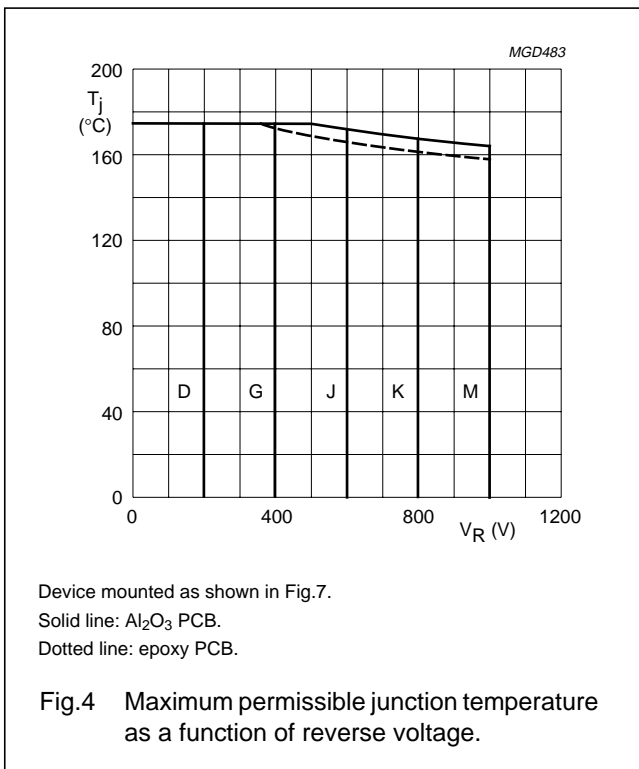
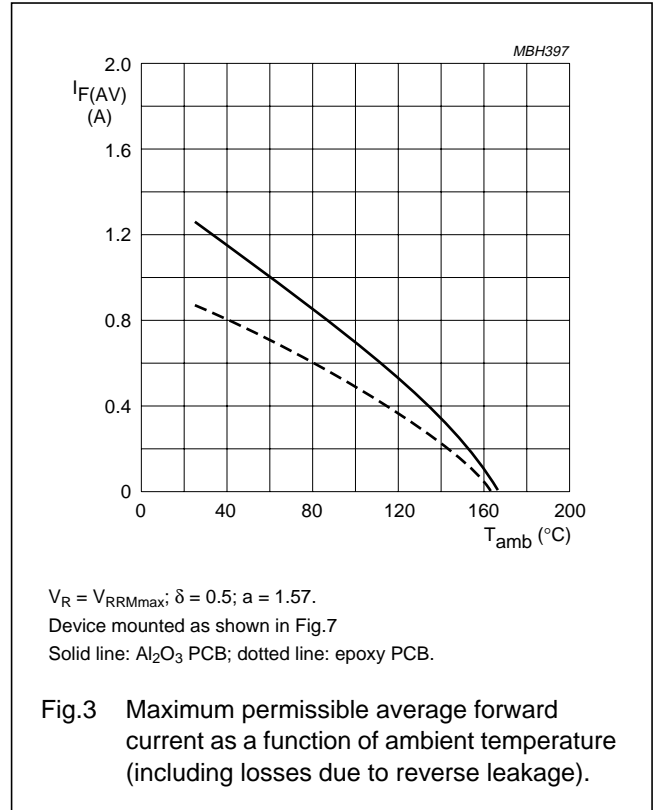
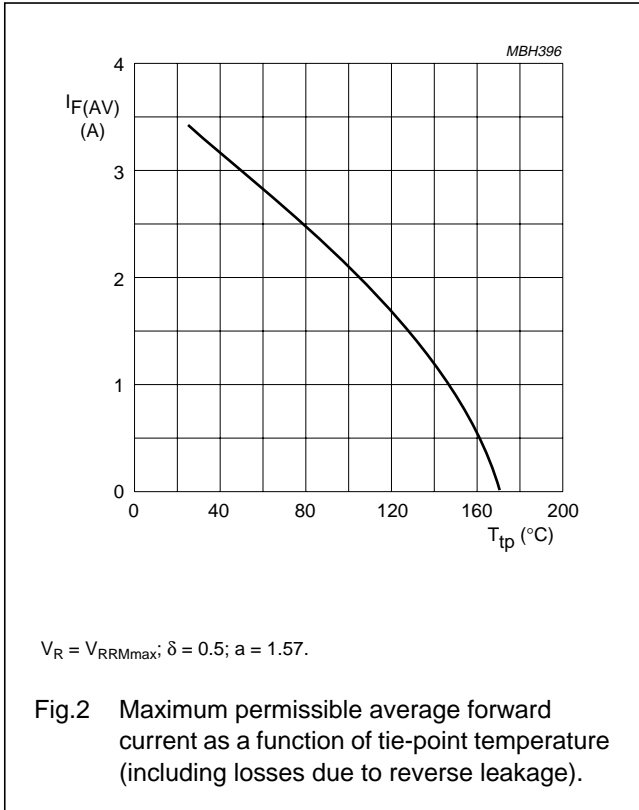

Controlled avalanche rectifiers

BYG50 series

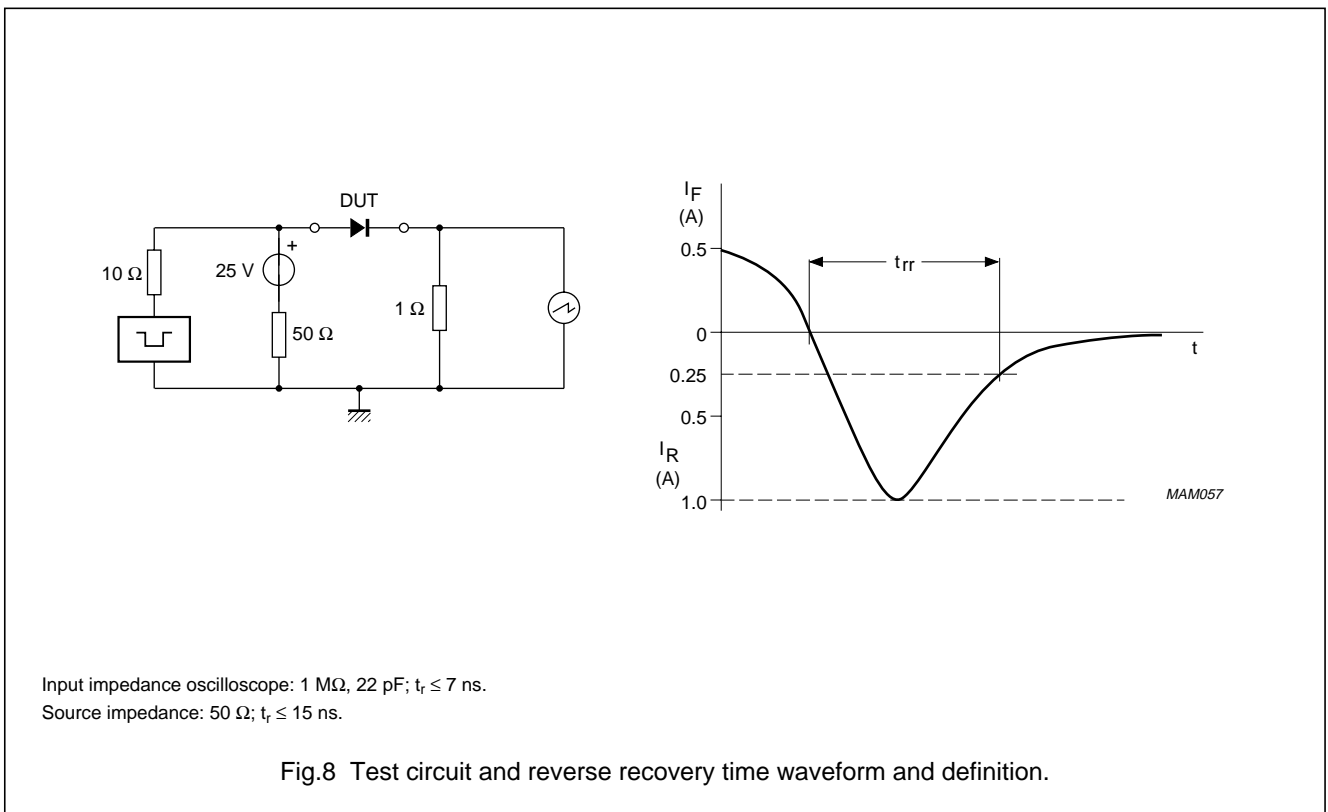
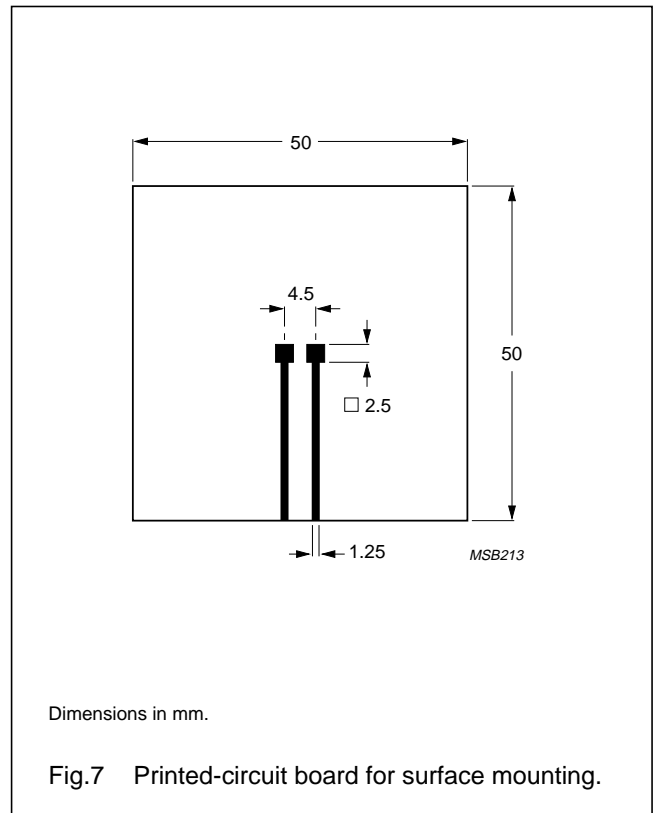
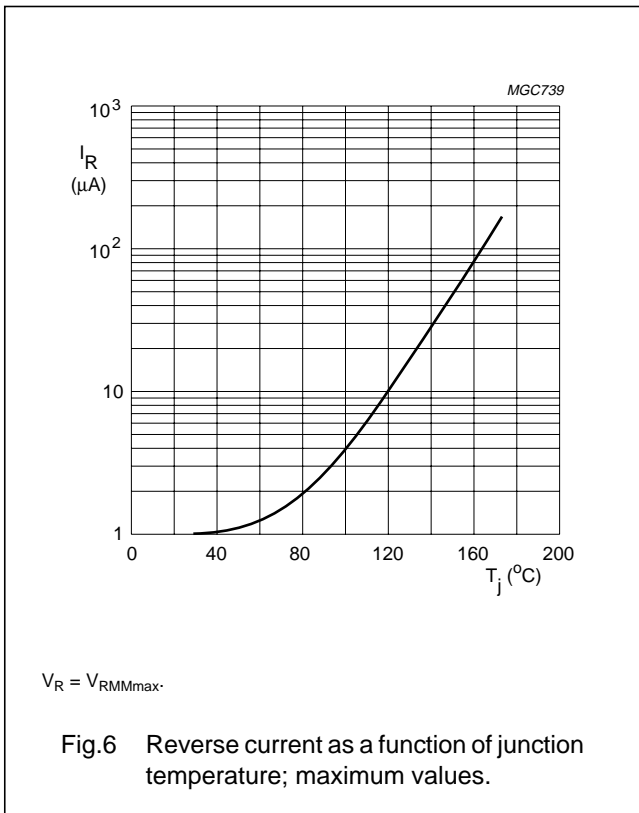

Controlled avalanche rectifiers

BYG50 series

PACKAGE OUTLINE

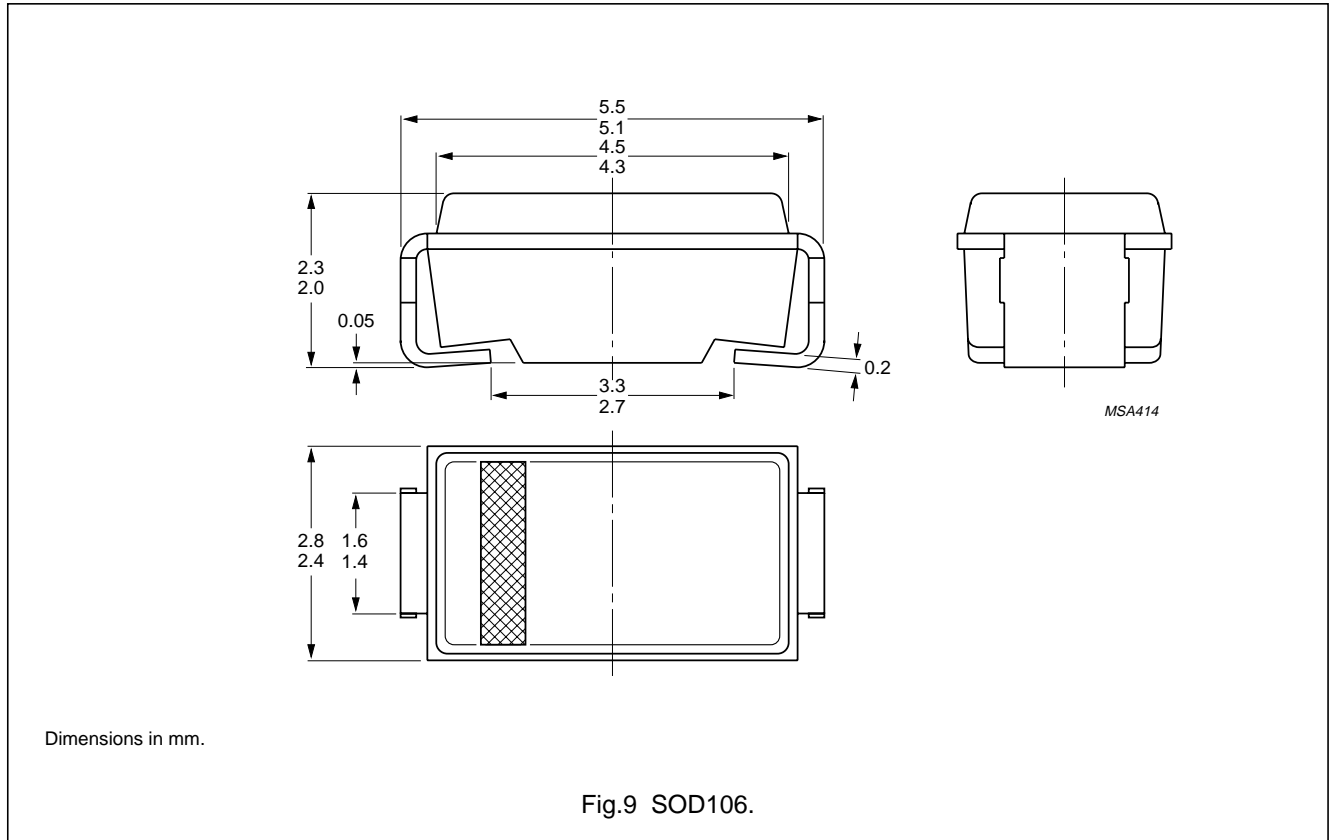

DEFINITIONS

Data sheet status	
Objective specification	This data sheet contains target or goal specifications for product development.
Preliminary specification	This data sheet contains preliminary data; supplementary data may be published later.
Product specification	This data sheet contains final product specifications.
Limiting values	
Limiting values given are in accordance with the Absolute Maximum Rating System (IEC 134). Stress above one or more of the limiting values may cause permanent damage to the device. These are stress ratings only and operation of the device at these or at any other conditions above those given in the Characteristics sections of the specification is not implied. Exposure to limiting values for extended periods may affect device reliability.	
Application information	
Where application information is given, it is advisory and does not form part of the specification.	

LIFE SUPPORT APPLICATIONS

These products are not designed for use in life support appliances, devices, or systems where malfunction of these products can reasonably be expected to result in personal injury. Philips customers using or selling these products for use in such applications do so at their own risk and agree to fully indemnify Philips for any damages resulting from such improper use or sale.



LittleDiode supplies new, hard to find or obsolete electronic components and semiconductors all over the world.

With over two million different components listed you are sure to find the part you need.

Feel free to visit us today at our online store:

LittleDiode.com

Looking forward to providing you with the best possible service.