

FRED Diode

- Fast recovery epitaxial diode
- Soft recovery characteristics

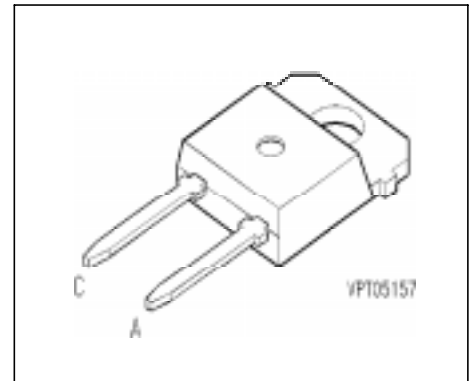

Type	V_{RRM}	I_{FRMS}	t_{rr}	Package	Ordering Code
BYP 101	1000V	25A	80ns	TO-218 AD	C67047-A2072-A2

Maximum Ratings

Parameter	Symbol	Values	Unit
Mean forward current $T_C = 90\text{ °C}, D = 0.5$	I_{FAV}	15	A
RMS forward current	I_{FRMS}	25	
Surge forward current, sine halfwave, aperiodic $T_j = 100\text{ °C}, f = 50\text{ Hz}$	I_{FSM}	70	
Repetitive peak forward current $T_j = 100\text{ °C}, t_p \leq 10\text{ }\mu\text{s}$	I_{FRM}	150	A ² s
i^2t value $T_j = 100\text{ °C}, t_p = 10\text{ ms}$	$\int I^2 dt$	25	
Repetitive peak reverse voltage	V_{RRM}	1000	V
Surge peak reverse voltage	V_{RSM}	1000	
Power dissipation $T_C = 90\text{ °C}$	P_{tot}	40	W
Chip or operating temperature	T_j	-40 ... + 150	°C
Storage temperature	T_{stg}	-40 ... + 150	
Thermal resistance, chip case	R_{thJC}	≤ 1.5	K/W
Thermal resistance, chip-ambient	R_{thJA}	≤ 46	
DIN humidity category, DIN 40 040	-	E	-
IEC climatic category, DIN IEC 68-1	-	40 / 150 / 56	-

Electrical Characteristics, at $T_j = 25\text{ °C}$, unless otherwise specified

Parameter	Symbol	Values			Unit
		min.	typ.	max.	

Static Characteristics

Forward voltage drop $I_F = 15\text{ A}$, $T_j = 25\text{ °C}$ $I_F = 15\text{ A}$, $T_j = 100\text{ °C}$	V_F	-	2 1.7	2.4 -	V
Reverse current $V_R = 1000\text{ V}$, $T_j = 25\text{ °C}$ $V_R = 1000\text{ V}$, $T_j = 100\text{ °C}$ $V_R = 1000\text{ V}$, $T_j = 150\text{ °C}$	I_R	-	0.01 0.05 0.15	0.25 - -	mA

AC Characteristics

Reverse recovery charge $I_F = 15\text{ A}$, $V_{CC} = 300\text{ V}$, $dI_F/dt = -1000\text{ A}/\mu\text{s}$ $T_j = 100\text{ °C}$	Q_{rr}	-	2.2	-	μC
Peak reverse recovery current $I_F = 15\text{ A}$, $V_{CC} = 300\text{ V}$, $dI_F/dt = -1000\text{ A}/\mu\text{s}$ $T_j = 100\text{ °C}$	I_{RRM}	-	35	-	A
Reverse recovery time $I_F = 15\text{ A}$, $V_{CC} = 300\text{ V}$, $dI_F/dt = -1000\text{ A}/\mu\text{s}$ $T_j = 100\text{ °C}$	t_{rr}	-	80	-	ns
Storage time $I_F = 15\text{ A}$, $V_{CC} = 300\text{ V}$, $dI_F/dt = -1000\text{ A}/\mu\text{s}$ $T_j = 100\text{ °C}$	t_S	-	45	-	
Softfaktor $I_F = 15\text{ A}$, $V_{CC} = 300\text{ V}$, $dI_F/dt = -1000\text{ A}/\mu\text{s}$ $T_j = 100\text{ °C}$	S	-	0.8	-	-

Typ. forward characteristics

$$I_F = f(V_F)$$

parameter: T_j

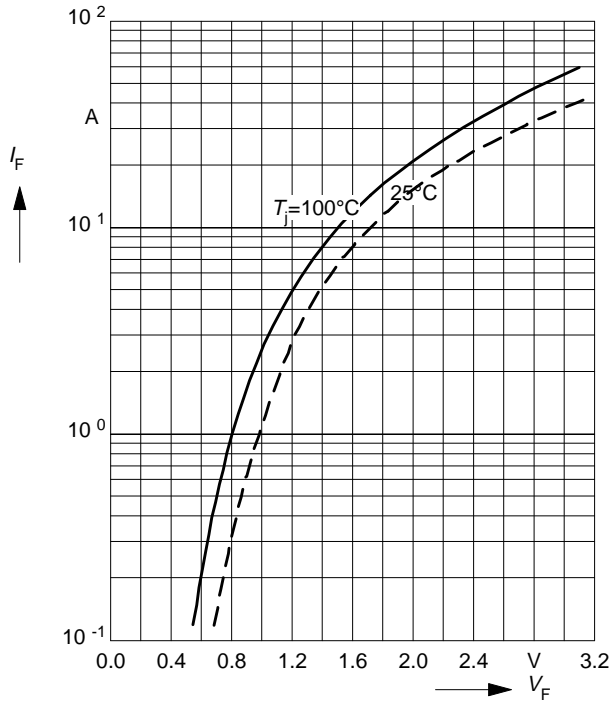

Typ. reverse current

$$I_{RRM} = f(dI_F / dt)$$

parameter: $V_{CC} = 300\text{ V}, I_F = 15\text{ A}, T_j = 100^\circ\text{C}$

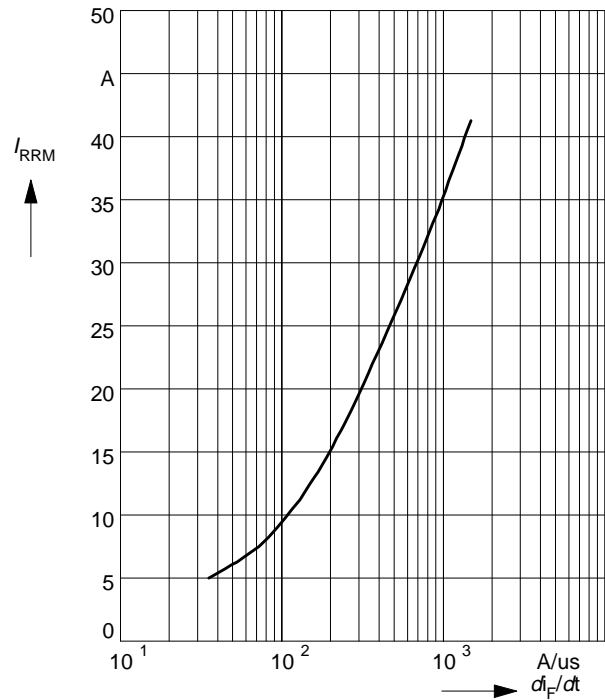

Typ. reverse recovery charge

$$Q_{rr} = f(dI_F / dt)$$

parameter: $V_{CC} = 300\text{ V}, I_F = 15\text{ A}, T_j = 100^\circ\text{C}$

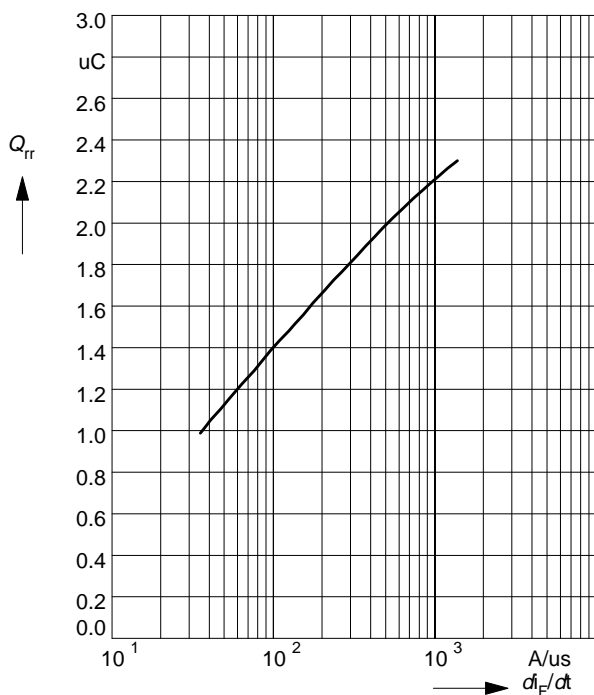



LittleDiode supplies new, hard to find or obsolete electronic components and semiconductors all over the world.

With over two million different components listed you are sure to find the part you need.

Feel free to visit us today at our online store:

LittleDiode.com

Looking forward to providing you with the best possible service.