

Fast Recovery Silicon Power Rectifier

Features

- Multiple diffusion
- Low switch on power losses
- Good soft recovery behaviour
- Fast forward recovery time
- Fast reverse recovery time
- Low reverse current
- Very low turn on transient peak voltage
- Very good reverse current stability at high temperature
- Low thermal resistance

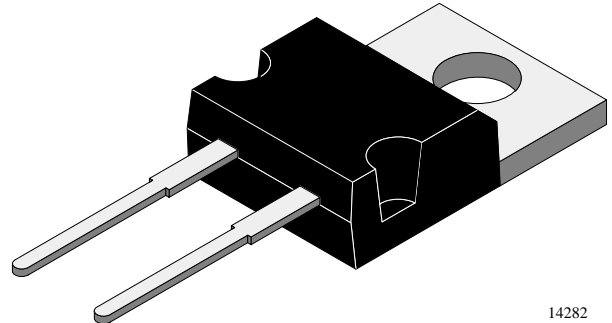

14282

Applications

Fast rectifiers in S.M.P.S
 Freewheeling diodes and snubber diodes in motor control circuits

Absolute Maximum Ratings

 $T_j = 25^\circ\text{C}$

Parameter	Test Conditions	Type	Symbol	Value	Unit
Reverse voltage =Repetitive peak reverse voltage		BYT08P/600A	$V_R=V_{RRM}$	600	V
		BYT08P/800A	$V_R=V_{RRM}$	800	V
Peak forward surge current	$t_p=10\text{ms}$, half sinewave		I_{FSM}	50	A
Repetitive peak forward current			I_{FRM}	16	A
Average forward current			I_{FAV}	8	A
Junction and storage temperature range			$T_j=T_{stg}$	-40...+150	$^\circ\text{C}$

Maximum Thermal Resistance

 $T_j = 25^\circ\text{C}$

Parameter	Test Conditions	Symbol	Value	Unit
Junction case		R_{thJC}	2.0	K/W
Junction ambient		R_{thJA}	85	K/W

Electrical Characteristics

$T_j = 25^\circ\text{C}$

Parameter	Test Conditions	Type	Symbol	Min	Typ	Max	Unit
Forward voltage	$I_F=8\text{A}$		V_F			1.9	V
	$I_F=8\text{A}, T_j=100^\circ\text{C}$		V_F			1.8	V
Reverse current	$V_R=V_{RRM}$		I_R			35	μA
	$V_R=V_{RRM}, T_j=100^\circ\text{C}$		I_R			2	mA
Forward recovery time	$I_F=8\text{A}; di_F/dt \leq 50\text{A}/\mu\text{s}$		t_{fr}		350		ns
Turn on transient peak voltage			V_{FP}			4,5	V
Reverse recovery characteristics	$I_F=8\text{A}, di_F/dt \leq -32\text{A}/\mu\text{s}, V_{Batt}=200\text{V}, T_j=100^\circ\text{C}$		I_{RM}			4	A
			t_{IRM}			160	ns
Reverse recovery time	$I_F=8\text{A}, di_F/dt \leq -32\text{A}/\mu\text{s}, V_{Batt}=200\text{V}, T_j=100^\circ\text{C}, i_R=0.25 \times I_{RM}$		t_{rr}		100		ns
		$I_F=0.5\text{A}, I_R=1\text{A}, i_R=0.25\text{A}$		t_{rr}		50	ns
Reverse recovery current	$I_F=1\text{A}, di_F/dt \leq -50\text{A}/\mu\text{s}, V_{Batt}=200\text{V}$		I_{RM}		1.7		A
Reverse recovery time	$I_F=1\text{A}, di_F/dt \leq -50\text{A}/\mu\text{s}, V_{Batt}=200\text{V}, i_R=0.25 \times I_{RM}$		t_{rr}		75		ns

Characteristics ($T_j = 25^\circ\text{C}$ unless otherwise specified)

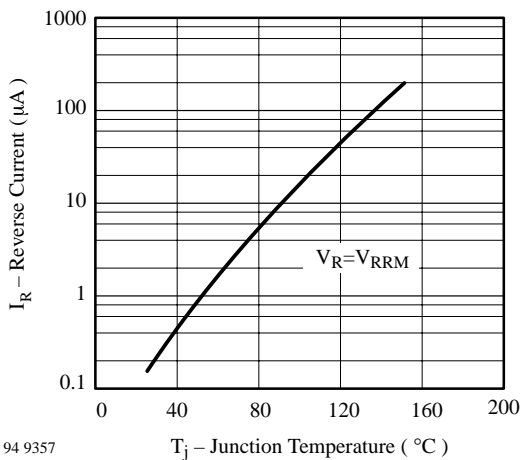

Figure 1. Typ. Reverse Current vs. Junction Temperature

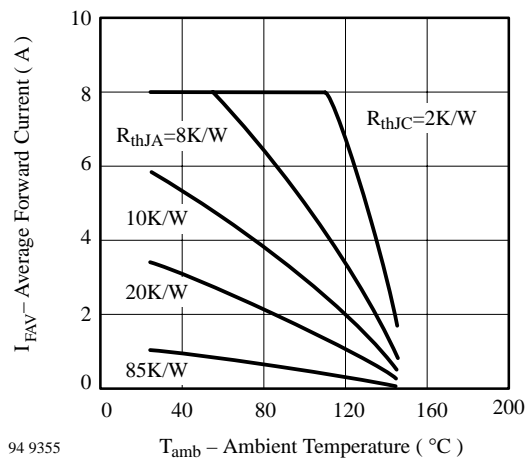

Figure 2. Max. Average Forward Current vs. Ambient Temperature

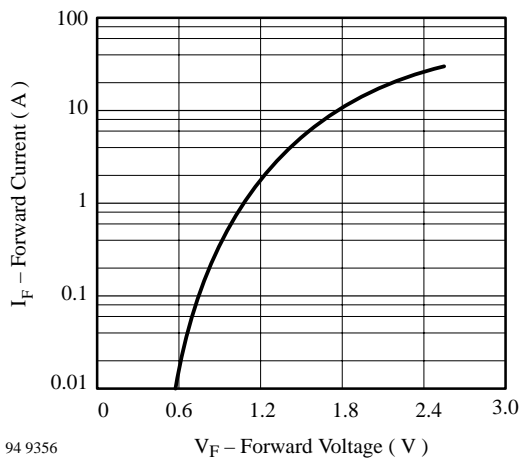

Figure 3. Typ. Forward Current vs. Forward Voltage

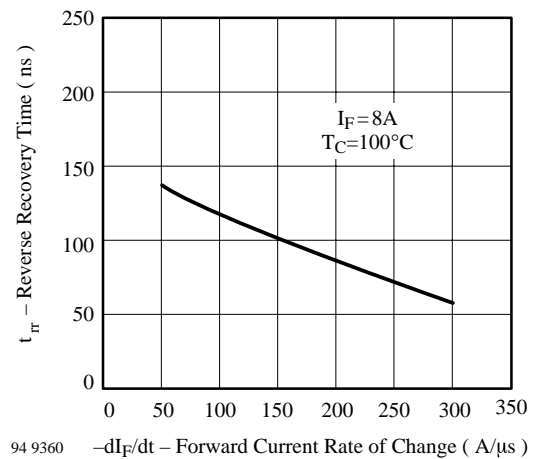

Figure 6. Reverse Recovery Time vs. Forward Current Rate of Change

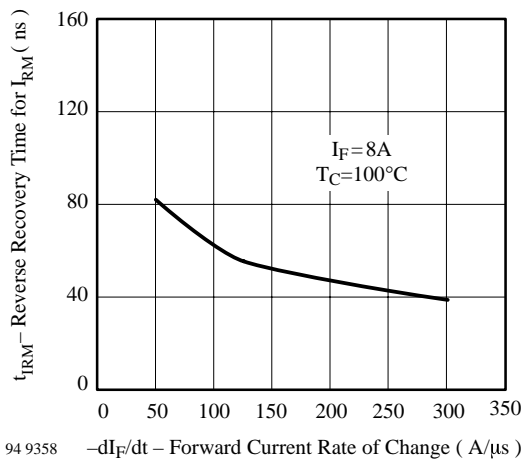

Figure 4. Reverse Recovery Time for I_{RM} vs. Forward Current Rate of Change

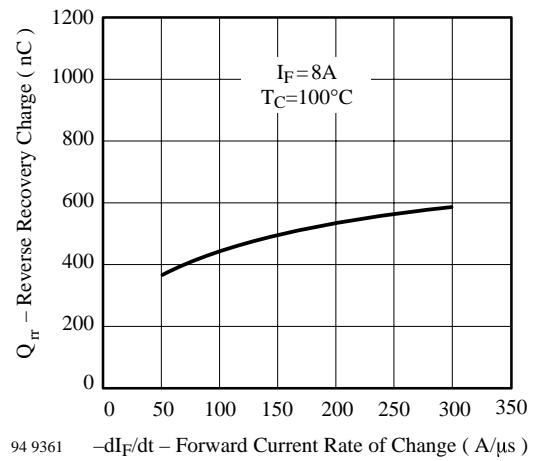

Figure 7. Reverse Recovery Charge vs. Forward Current Rate of Change

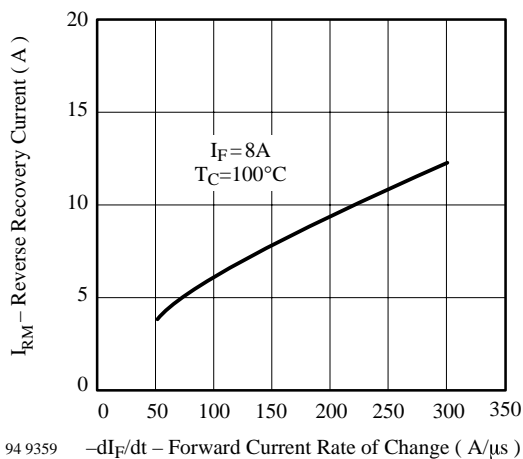
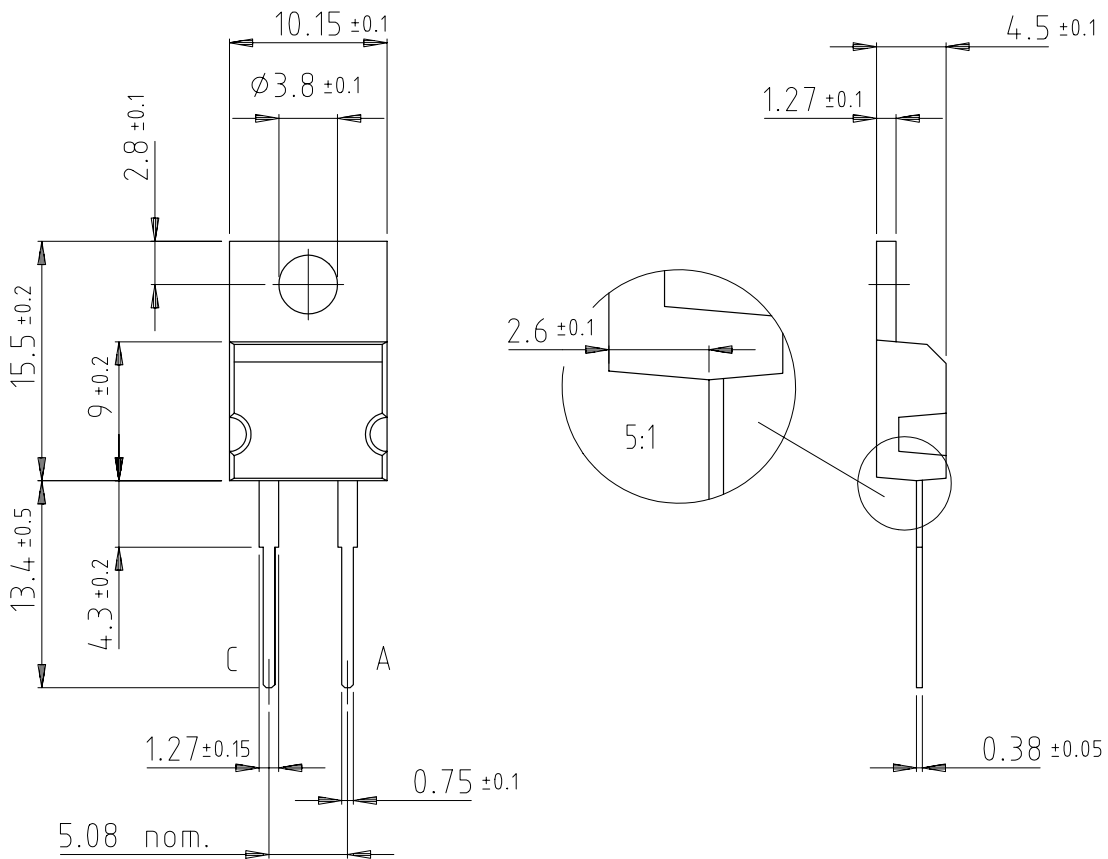
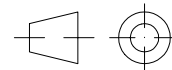

Figure 5. Reverse Recovery Current vs. Forward Current Rate of Change

Dimensions in mm



Plastic case JEDEC DO 220
Cathode connected with metallic surface



technical drawings
according to DIN
specifications

14276



Ozone Depleting Substances Policy Statement

It is the policy of **Vishay Semiconductor GmbH** to

1. Meet all present and future national and international statutory requirements.
2. Regularly and continuously improve the performance of our products, processes, distribution and operating systems
with respect to their impact on the health and safety of our employees and the public, as well as their impact on the environment.

It is particular concern to control or eliminate releases of those substances into the atmosphere which are known as ozone depleting substances (ODSs).

The Montreal Protocol (1987) and its London Amendments (1990) intend to severely restrict the use of ODSs and forbid their use within the next ten years. Various national and international initiatives are pressing for an earlier ban on these substances.

Vishay Semiconductor GmbH has been able to use its policy of continuous improvements to eliminate the use of ODSs listed in the following documents.

1. Annex A, B and list of transitional substances of the Montreal Protocol and the London Amendments respectively
2. Class I and II ozone depleting substances in the Clean Air Act Amendments of 1990 by the Environmental Protection Agency (EPA) in the USA
3. Council Decision 88/540/EEC and 91/690/EEC Annex A, B and C (transitional substances) respectively.

Vishay Semiconductor GmbH can certify that our semiconductors are not manufactured with ozone depleting substances and do not contain such substances.

We reserve the right to make changes to improve technical design and may do so without further notice.

Parameters can vary in different applications. All operating parameters must be validated for each customer application by the customer. Should the buyer use Vishay-Telefunken products for any unintended or unauthorized application, the buyer shall indemnify Vishay-Telefunken against all claims, costs, damages, and expenses, arising out of, directly or indirectly, any claim of personal damage, injury or death associated with such unintended or unauthorized use.

Vishay Semiconductor GmbH, P.O.B. 3535, D-74025 Heilbronn, Germany
Telephone: 49 (0) 7131 67 2831, Fax number: 49 (0) 7131 67 2423

This datasheet has been downloaded from:

www.DatasheetCatalog.com

Datasheets for electronic components.



LittleDiode supplies new, hard to find or obsolete electronic components and semiconductors all over the world.

With over two million different components listed you are sure to find the part you need.

Feel free to visit us today at our online store:

LittleDiode.com

Looking forward to providing you with the best possible service.