

The RF Line VHF/UHF CATV Amplifiers

Designed for broadband applications requiring low-distortion and high output capability. Specifically intended for CATV/MATV market requirements. These amplifiers feature ion-implanted arsenic emitter transistors and an all gold metal system.

- Specified Characteristics at $V_{CC} = 24\text{ V}$, $T_C = 25^\circ\text{C}$
 - Frequency Range — 40 to 860 MHz
 - Power Gain — 17 dB Typ @ $f = 40\text{ MHz}$
 - Noise Figure — 7.0 dB Typ @ $f = 500\text{ MHz}$
 - 123 dB μV DIN45004B @ 860 MHz
- All Gold Metalization for Improved Reliability
- Superior Gain, Return Loss and DC Current Stability with Temperature
- Improved 2nd Order IMD Available (CA922A)

CA922
CA922A

17 dB
40–860 MHz
VHF/UHF
CATV/MATV
AMPLIFIERS

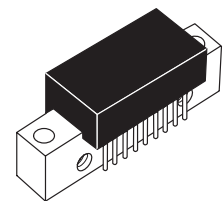

CASE 714P-03, STYLE 2

MAXIMUM RATINGS

Rating	Symbol	Value	Unit
Supply Voltage	V_{CC}	26	V
RF Input Power Per Tone	P_{in}	+16	dBm
Storage Temperature	T_{stg}	- 40 to +100	$^\circ\text{C}$
Operating Case Temperature Range	T_C	- 20 to +100	$^\circ\text{C}$

ELECTRICAL CHARACTERISTICS ($T_C = 25^\circ\text{C}$, $V_{CC} = 24\text{ V}$, 75 Ohm System)

Characteristic	Symbol	Min	Typ	Max	Unit
Supply Current	I_{dc}	—	400	440	mA
Power Gain ($f = 40\text{ MHz}$)	PG	16.5	17	17.5	dB
Bandwidth	BW	40	—	860	MHz
Slope (40 – 860 MHz)	S	0.2	0.8	1.5	dB
Gain Flatness	FL	—	—	1.0	dB
Input/Output Return Loss $f = 40\text{--}100\text{ MHz}$ $f = 100\text{--}800\text{ MHz}$ $f = 800\text{--}860\text{ MHz}$	IRL/ORL	20 15 10/13	— 17 12/15	— — —	dB
Second Order Intermodulation Distortion ($V_o = +50\text{ dBmV/ch.}$)	IMD ₂	—	—	- 63 - 67	dB dB
DIN45004B (See Figure 1) $f = 40\text{--}400\text{ MHz}$ $f = 400\text{--}860\text{ MHz}$	DIN	124 123	— —	— —	dB μV
Noise Figure $f = 500\text{ MHz}$ $f = 860\text{ MHz}$	NF	— —	7.0 8.0	8.5 9.5	dB



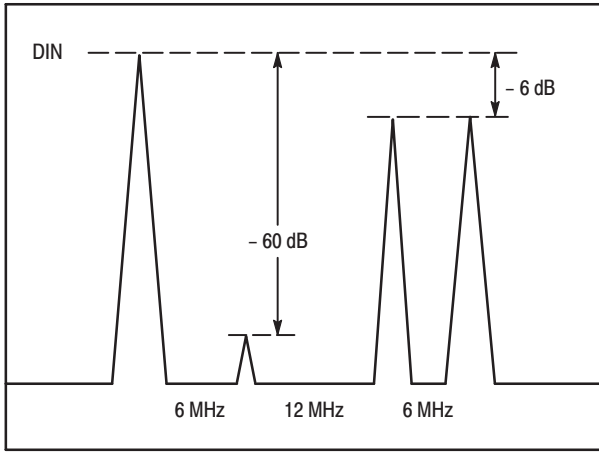

Figure 1. DIN45004B Test

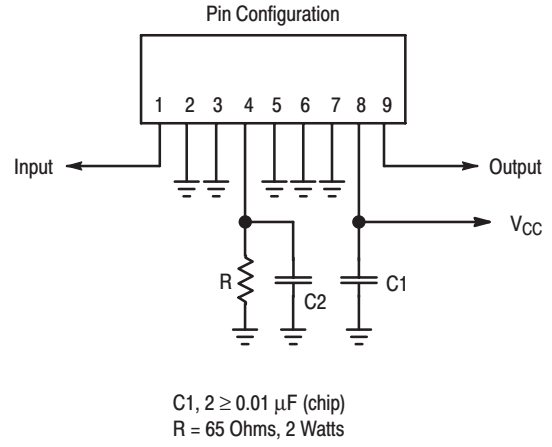
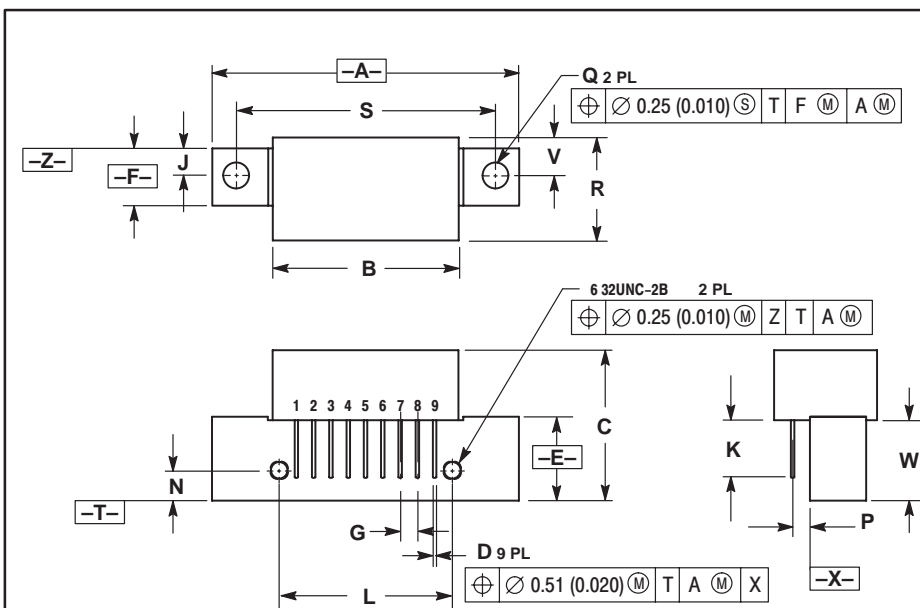

Figure 2. External Connections

PACKAGE DIMENSIONS



- NOTES:
 1. DIMENSIONING AND TOLERANCING PER ANSI Y14.5M, 1982.
 2. CONTROLLING DIMENSION: INCH.

DIM	INCHES		MILLIMETERS	
	MIN	MAX	MIN	MAX
A	---	1.775	---	45.08
B	---	1.085	---	27.56
C	---	0.870	---	22.10
D	0.018	0.022	0.46	0.56
E	0.465	0.510	11.81	12.95
F	0.300	0.325	7.62	8.25
G	0.100 BSC		2.54 BSC	
J	0.156 BSC		3.96 BSC	
K	0.330	0.370	8.38	9.40
L	1.000 BSC		25.40 BSC	
N	0.165 BSC		4.19 BSC	
P	0.100 BSC		2.54 BSC	
Q	0.148	0.168	3.76	4.27
R	---	0.595	---	15.11
S	---	1.500 BSC	---	38.10 BSC
V	0.209	0.239	5.31	6.07
W	0.425	---	10.80	---

- STYLE 2:
 PIN 1. RF INPUT
 2. GROUND
 3. GROUND
 4. RESISTOR-GROUND
 5. GROUND
 6. GROUND
 7. GROUND
 8. V_{CC} 1
 9. RF OUTPUT

**CASE 714P-03
 ISSUE B**

Motorola reserves the right to make changes without further notice to any products herein. Motorola makes no warranty, representation or guarantee regarding the suitability of its products for any particular purpose, nor does Motorola assume any liability arising out of the application or use of any product or circuit, and specifically disclaims any and all liability, including without limitation consequential or incidental damages. "Typical" parameters which may be provided in Motorola data sheets and/or specifications can and do vary in different applications and actual performance may vary over time. All operating parameters, including "Typicals" must be validated for each customer application by customer's technical experts. Motorola does not convey any license under its patent rights nor the rights of others. Motorola products are not designed, intended, or authorized for use as components in systems intended for surgical implant into the body, or other applications intended to support or sustain life, or for any other application in which the failure of the Motorola product could create a situation where personal injury or death may occur. Should Buyer purchase or use Motorola products for any such unintended or unauthorized application, Buyer shall indemnify and hold Motorola and its officers, employees, subsidiaries, affiliates, and distributors harmless against all claims, costs, damages, and expenses, and reasonable attorney fees arising out of, directly or indirectly, any claim of personal injury or death associated with such unintended or unauthorized use, even if such claim alleges that Motorola was negligent regarding the design or manufacture of the part. Motorola and  are registered trademarks of Motorola, Inc. Motorola, Inc. is an Equal Opportunity/Affirmative Action Employer.

MOTOROLA and the Stylized M Logo are registered in the US Patent & Trademark Office. All other product or service names are the property of their respective owners. © Motorola, Inc. 2001.

How to reach us:

USA/EUROPE/Locations Not Listed: Motorola Literature Distribution; P.O. Box 5405, Denver, Colorado 80217. 1-303-675-2140 or 1-800-441-2447

JAPAN: Motorola Japan Ltd.; SPS, Technical Information Center, 3-20-1, Minami-Azabu, Minato-ku, Tokyo 106-8573 Japan. 81-3-3440-3569

ASIA/PACIFIC: Motorola Semiconductors H.K. Ltd.; Silicon Harbour Centre, 2 Dai King Street, Tai Po Industrial Estate, Tai Po, N.T., Hong Kong. 852-26668334

Technical Information Center: 1-800-521-6274

HOME PAGE: <http://www.motorola.com/semiconductors/>





LittleDiode supplies new, hard to find or obsolete electronic components and semiconductors all over the world.

With over two million different components listed you are sure to find the part you need.

Feel free to visit us today at our online store:

LittleDiode.com

Looking forward to providing you with the best possible service.