



# CD4059A Types

## MAXIMUM RATINGS, Absolute-Maximum Values:

DC SUPPLY-VOLTAGE RANGE, ( $V_{DD}$ ) Voltages referenced to $V_{SS}$ Terminal)	-0.5V to +15V
INPUT VOLTAGE RANGE, ALL INPUTS	-0.5V to $V_{DD}$ +0.5V
POWER DISSIPATION PER PACKAGE ( $P_D$ ):	
For $T_A = -55^\circ\text{C}$ to $+100^\circ\text{C}$	500mW
For $T_A = +100^\circ\text{C}$ to $+125^\circ\text{C}$	Derate Linearly to 100mW
DEVICE DISSIPATION PER OUTPUT TRANSISTOR	
FOR $T_A =$ FULL PACKAGE-TEMPERATURE RANGE (All Package Types)	100mW
OPERATING-TEMPERATURE RANGE ( $T_A$ )	$-55^\circ\text{C}$ to $+125^\circ\text{C}$
STORAGE TEMPERATURE RANGE ( $T_{stg}$ )	$-85^\circ\text{C}$ to $+150^\circ\text{C}$
LEAD TEMPERATURE (DURING SOLDERING):	
At distance $1/16 \pm 1/32$ inch ( $1.59 \pm 0.79\text{mm}$ ) from case for 10s max	

## OPERATING CONDITIONS AT $T_A = 25^\circ\text{C}$ (Unless otherwise specified)

For maximum reliability, nominal operating conditions should be selected so that operation is always within the following ranges.

Characteristic	$V_{DD}$	Min.	Max.	Units
Supply Voltage Range (over full temp. range)	-	3	12	V
Clock Pulse Width	5	200	-	ns
Clock Input Frequency	10	-	1.5	MHz
Clock Input Rise and Fall Time	5	-	15	$\mu\text{s}$

## STATIC ELECTRICAL CHARACTERISTICS

Characteristic	Conditions			Limits							Units	
	$V_O$ (V)	$V_{IN}$ (V)	$V_{DD}$ (V)	$-55^\circ$	$-40^\circ$	$+85^\circ$	$+125^\circ$	$+25^\circ$				
								Min.	Typ.	Max.		
Quiescent Device Current, $I_L$ Max.			5 10 15	10 20	10 20	700 200	300 400	-	0.02 0.02	10 20 500	$\mu\text{A}$	
Output Voltage:												
Low Level, $V_{OL}$ Max.	0.5	0.10	5			0.05			-	0	0.05	V
High Level, $V_{OH}$ Min.	0.5	0.10	5			4.95			4.95	5	-	V
Noise Immunity:												
Inputs Low, $V_{NL}$ Min.			5			1.5			1.5	2.25	-	V
Inputs High, $V_{NH}$ Min.			10			3			3	4.5	-	V
Noise Margin:												
Inputs Low, $V_{NML}$ Min.	4.5		5				1					V
Inputs High, $V_{NMH}$ Min.	0.5		10				1					V
Output Drive Current:												
N-Channel (Sink) $I_{DN}$ Min.	0.4 0.5		5 10	2.5 5	2.3 4.7	1.6 3.3	1.4 2.8	2 4	4 9	-	-	mA
P-Channel (Source) $I_{DP}$ Min.	2.5 4.6 9.5		5 10	-2 -0.5	-1.8 -0.45	-1.3 -0.36	-1.15 -0.3	-1.6 -0.4	-3.2 -0.8	-	-	mA
Input Leakage Current: * $I_{IL}, I_{IH}$ Max.			15			$\pm 1$			$\pm 10^5$	$\pm 1$	$\mu\text{A}$	

\* Any Input

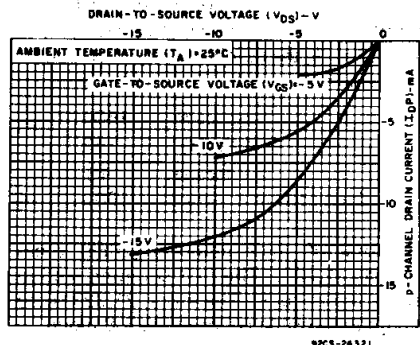
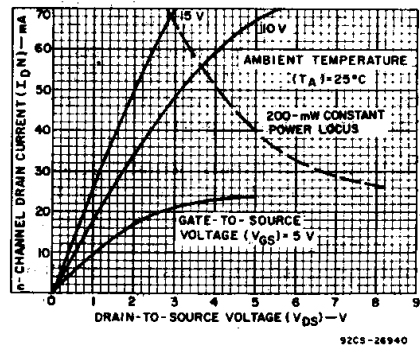
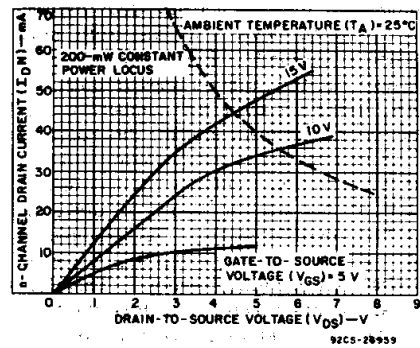

# CD4059A Types

DYNAMIC ELECTRICAL CHARACTERISTICS AT  $T_A = 25^\circ\text{C}$ ,  $C_L = 50\text{ pF}$ , Input  $t_r, t_f = 20\text{ ns}$ ,  $R_L = 200\text{ k}\Omega$

CHARACTERISTIC	CONDITIONS $V_{DD}$ (V)	LIMITS ALL PACKAGES			UNITS
		Min.	Typ.	Max.	
Propagation-Delay Time: $t_{PHL}, t_{PLH}$	5	—	180	360	ns
	10	—	90	180	
Transition Time:	$t_{THL}$	5	—	35	ns
		10	—	20	
	$t_{TLH}$	5	—	100	ns
		10	—	50	
Maximum Clock Input Frequency, $f_{CL}$	5	1.5	3	MHz	
	10	3	6		
Average Input Capacitance, $C_i$ (any input)	—	—	5	—	pF

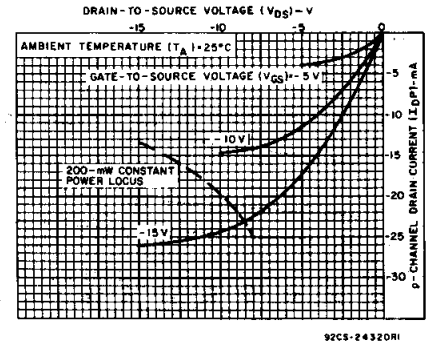

Fig. 6 - Typical output p-channel drain characteristics.

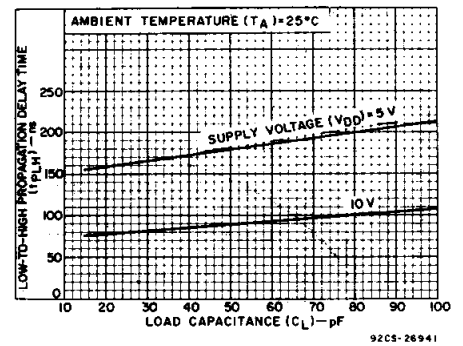

Fig. 7 - Typical low-to-high propagation delay time vs. load capacitance.

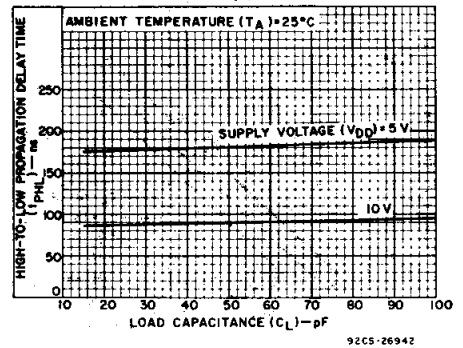

Fig. 8 - Typical high-to-low propagation delay time vs. load capacitance.

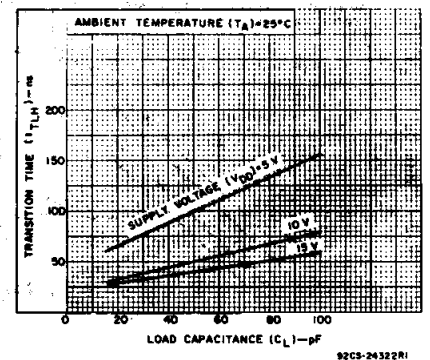
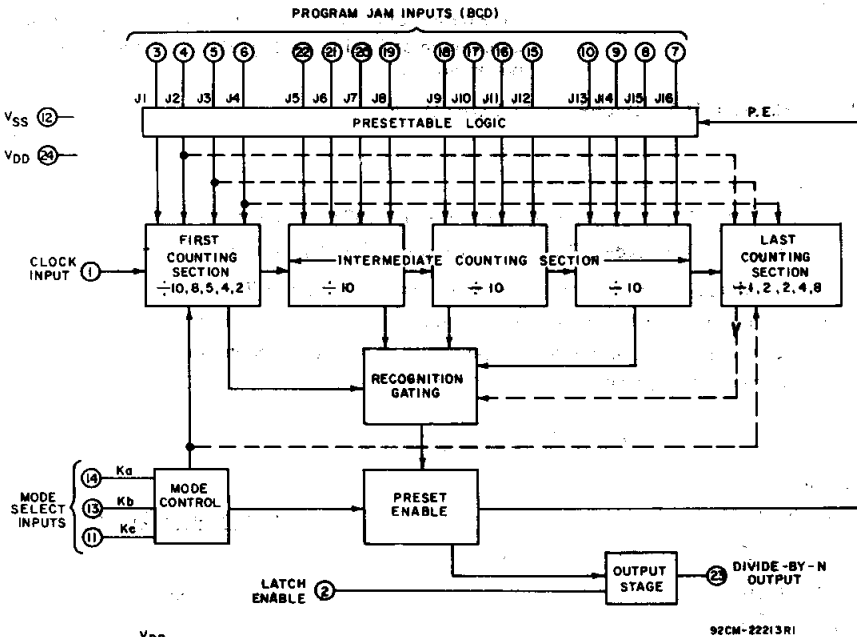
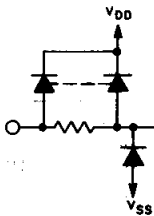

Fig. 9 - Typical low-to-high transition time vs. load capacitance.



ALL INPUTS (TERMS. 1-11, 13-22) PROTECTED BY CMOS PROTECTION NETWORK

Fig. 5 - Functional block diagram.



4  
COMMERCIAL CMOS  
SPECIAL FUNCTION ICs

# CD4059A Types

TABLE I

MODE SELECT INPUT			FIRST COUNTING SECTION			LAST COUNTING SECTION			COUNTER RANGE	
									DESIGN	EXTENDED
Ka	Kb	Kc	MODE	Can be preset to a max of:	Jam <sup>▲</sup> inputs used:	MODE	Can be preset to a max of:	Jam <sup>▲</sup> inputs used:	Max.	Max.
			Divides by:			Divides by:				
1	1	1	2	1	J1	8	7	J2,J3,J4	15,999	17,331
0	1	1	4	3	J1,J2	4	3	J3,J4	15,999	18,663
1	0	1	5 <sup>#</sup>	4	J1,J2,J3	2	1	J4	9,999	13,329
0	0	1	8	7	J1,J2,J3	2	1	J4	15,999	21,327
1	1	0	10	9	J1,J2,J3,J4	1	0	—	9,999	16,659
X	0	0	MASTER PRESET			MASTER PRESET			—	—

X = Don't Care

▲ J1 = Least significant bit.

J4 = Most significant bit.

# Operation in the ÷5 mode (1<sup>st</sup> counting section) requires going through the Master Preset mode prior to going into the ÷5 mode. At power turn-on, kc must be a logic "0" for a period of 3 input clock pulses after V<sub>DD</sub> reaches a minimum of 3 volts. See Fig. 21 for a suggested external preset circuit.

## HOW TO PRESET THE CD4059A TO DESIRED ÷ N

The value N is determined as follows:

$$N = [\text{MODE}^*] \cdot [1000 \times \text{Decade 5 Preset} + 100 \times \text{Decade 4 Preset} + 10 \times \text{Decade 3 Preset} + 1 \times \text{Decade 2 Preset}] + \text{Decade 1 Preset} \quad (1)$$

\* MODE = First counting section divider (10, 8, 5, 4 or 2)

To calculate preset values for any N count, divide the N count by the Mode.

The resultant is the corresponding preset values of the 5th through 2nd decade with the remainder being equal to the 1st decade value.

$$\text{Preset Value} = \frac{N}{\text{Mode}} \quad (2)$$

Examples:

A) N = 8479, Mode = 5

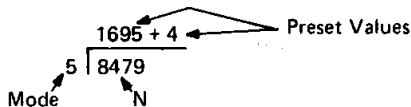

MODE SELECT = 5

Ka Kb Kc  
1 0 1

## PROGRAM JAM INPUTS (BCD)

4				1				5				9				6			
J1	J2	J3	J4	J5	J6	J7	J8	J9	J10	J11	J12	J13	J14	J15	J16				
0	0	1	1	1	0	1	0	1	0	0	1	0	1	1	0				

To verify the results use equation 1 :

$$N = 5 (1000 \times 1 + 100 \times 6 + 10 \times 9 + 1 \times 5) + 4$$

$$N = 8479$$

MODE SELECT = 8

B) N = 12382, Mode = 8

$$1547 + 6$$

$$8 \overline{) 12382}$$

Ka Kb Kc  
0 0 1

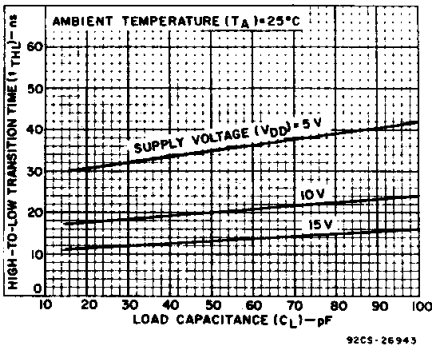

Fig.10 – Typical high-to-low transition time vs. load capacitance.

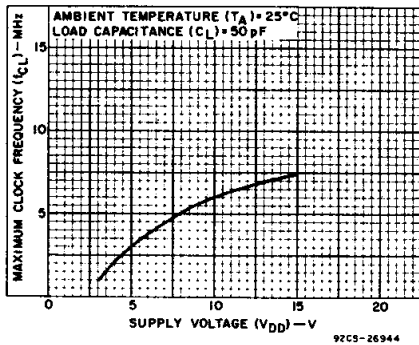

Fig.11 – Typical max. clock frequency vs. supply voltage.

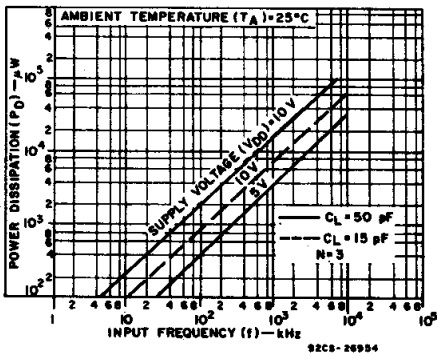

Fig.12 – Typical power dissipation vs. input frequency.

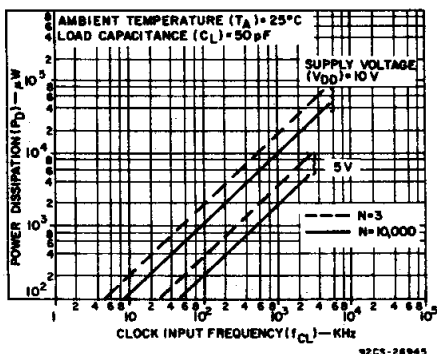

Fig.13 – Typical power dissipation vs. clock input frequency.

# CD4059A Types

PROGRAM JAM INPUTS																			
6				1				7				4				5			
J1	J2	J3	J4	J5	J6	J7	J8	J9	J10	J11	J12	J13	J14	J15	J16				
0	1	1	1	1	1	1	0	0	0	1	0	1	0	1	0				

To verify:

$$N = 8 (1000 \times 1 + 100 \times 5 + 10 \times 4 + 1 \times 7) + 6$$

$$N = 12382$$

MODE SELECT = 10

C) N = 8479, Mode = 10

$$10 \overline{) 08479} \\ \underline{80} \\ 47 \\ \underline{40} \\ 79$$

Ka Kb Kc  
1 1 0

PROGRAM JAM INPUTS															
9				7				4				8			
J1	J2	J3	J4	J5	J6	J7	J8	J9	J10	J11	J12	J13	J14	J15	J16
1	0	0	1	1	1	1	0	0	0	1	0	0	0	0	1

To Verify:

$$N = 10 (1000 \times 0 + 100 \times 8 + 10 \times 4 + 1 \times 7) + 9$$

$$N = 8479$$

## DIGITAL PHASE-LOCKED LOOP (PLL) FOR FM BAND SYNTHESIZER

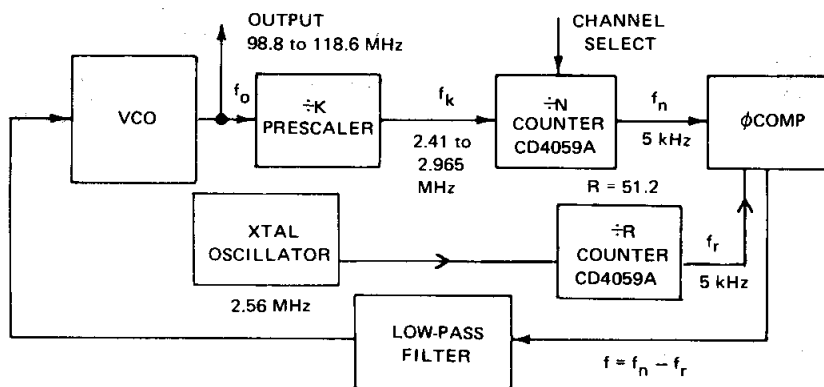

### 1) Calculating Min & Max "N" Values :

Output Freq. Range ( $f_o$ ) = 98.8 to 118.6 MHz

Channel Spacing Freq. ( $f_c$ ) = 200 kHz

Division Factor ( $k$ ) = 40

$$\text{Reference Freq. } (f_r) = \frac{f_c}{k} = \frac{200}{40} \text{ kHz} = 5 \text{ kHz}$$

$$f_k = \frac{f_o}{40} : f_{k\text{Max.}} = \frac{118.6 \text{ MHz}}{40} = 2.965 \text{ MHz}; f_{k\text{Min.}} = \frac{98.8 \text{ MHz}}{40} = 2.47 \text{ MHz}$$

$$\therefore N = \frac{f_o}{f_c}$$

$$N_{\text{Max}} = \frac{118.6 \text{ MHz}}{200 \text{ kHz}} = 593$$

$$N_{\text{Min}} = \frac{98.8 \text{ MHz}}{200 \text{ kHz}} = 494$$

$$R = \frac{2.56 \text{ MHz}}{5 \text{ kHz}} = 512$$

## "CASCADING" VIA OTHER COUNTERS

Fig. 14 shows a BCD-switch compatible arrangement suitable for  $\div 8$  and  $\div 5$  modes, which can be adapted, with slight changes, to the other divide-by-modes. In order to be able to preset to any number from three to about 256,000, while preserving the BCD-switch compatible character of the jam inputs, a rather complex cascading scheme is required. Such a cascading scheme is necessary because the CD4059A can never be preset to a count less than 3 and logic is needed to detect the condition that one of the numbers to be preset in the CD4059A is rather small. In order to simplify the detection logic, only that condition is detected where the jam inputs to terminals 6, 7, and 9 would be low during one count. If such a condition is detected, and if at least 1 is expected to be jammed into the MSB counter, the detection logic removes one from the number to be jammed into the MSB counter (with a place value of 2000 times the divide-by-mode) and jams the same 2000 into the CD4059A by forcing terminals 6, 7, and 9 high.

The clock of the CD4013A may be driven directly from the output of the CD4059A, as shown by dashed option (1), or by the inverted output of the CD4059A, option (2). If option (2) is used the CD4029A cannot count cycles shorter than 3. If option (1) is used propagation delay problems may occur at high counting speeds.

The general circuit in Fig.14 can be simplified considerably if the range of the cascaded counters does not have to start at a very low value. Fig.15 shows an arrangement in the  $\div 4$  mode, where the counting range extends in a BCD-switch compatible manner from 88,003 to 103,999. The arrangement shown in Fig.15 is easy to follow; once during each cycle, the less significant digits are jammed in (14,712 in this case) and then 11,000 ( $4 \times 2750$ ) is jammed in eight times in succession, by forcing jam inputs high or low, as required.

Numbers larger than the extended counter range can also be produced by cascading the CD4059A with some other counting device. Fig.16 shows such an arrangement where only one fixed divide-by number is desired which is close to three times the extended counter range as shown in the last column of Table I. The dual flip-flop wired to produce a  $\div 3$  count, can be replaced by other counters such as the CD4029, CD4510, CD4516, CD4017, or the CD4022. In Fig.16 the  $\div N$  subsystem is preset once to a number smaller than the desired divide-by number. This smaller number represents the less significant digits of the divide-by number. The subsystem is then preset one or more times to a round number (e.g. 1000, 2000) and multiplied by the number of the divide-by mode ( $\div 2$  in the example of Fig.16). It is important that the second counting device has an output that is high or low, as the case may be, during only one of its counting states.

4  
COMMERCIAL CMOS  
SPECIAL FUNCTION ICs

## CD4059A Types

### 2) ÷ N Counter Configuration for UHF – 220 to 400 MHz

Channel Spacing: 50 kHz or 25 kHz

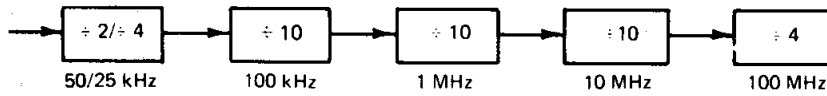

$$N_{Max} = \frac{400 \text{ MHz}}{25 \text{ kHz}} = 16,000 \quad N_{Max} = \frac{400 \text{ MHz}}{50 \text{ kHz}} = 8,000$$

$$N_{Min} = \frac{220 \text{ MHz}}{25 \text{ kHz}} = 8,800 \quad N_{Min} = \frac{220 \text{ MHz}}{50 \text{ kHz}} = 4,400$$

### 3) ÷ N Counter Configuration to VHF – 116 MHz

Channel Spacing = 12.5 kHz

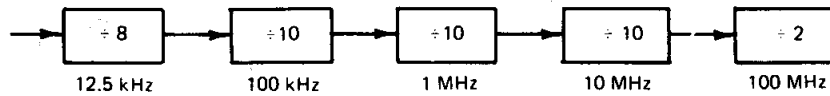

$$N_{Max} = \frac{160 \text{ MHz}}{12.5 \text{ kHz}} = 12,800 \quad N_{Min} = \frac{116 \text{ MHz}}{12.5 \text{ kHz}} = 9,300$$

### 4) ÷ N Counter Configuration for VHF – 30 to 80 MHz

Channel Spacing: 25 kHz

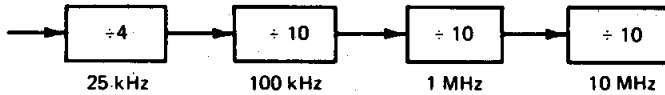

$$N_{Max} = \frac{80 \text{ MHz}}{25 \text{ kHz}} = 3,200 \quad N_{Min} = \frac{30 \text{ MHz}}{25 \text{ kHz}} = 1,200$$

### 5) ÷ N Counter Configuration for AM – 995 to 2055 kHz

Channel Spacing = 10 kHz

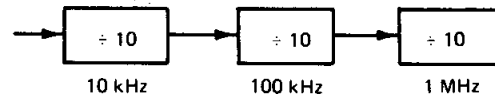

$$N_{Max} = \frac{2055 \text{ kHz}}{10 \text{ kHz}} = 205 \quad N_{Min} = \frac{995 \text{ kHz}}{10 \text{ kHz}} = 99$$

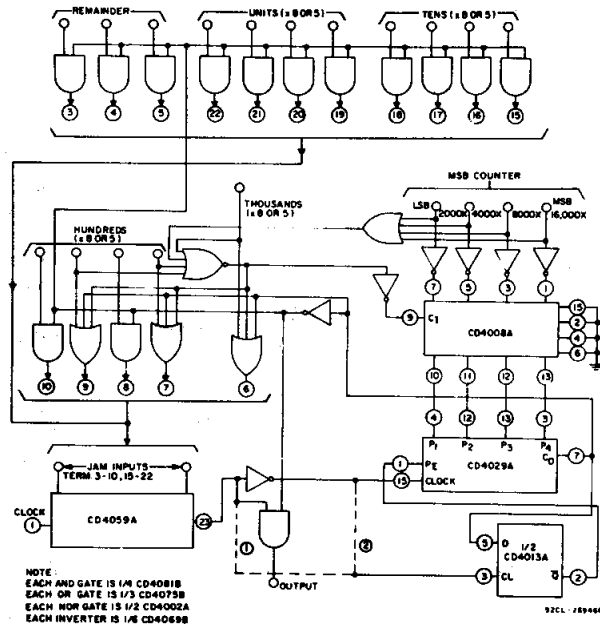

**Fig.14 – BCD switch-compatible ÷N system of the most general kind.**

# CD4059A Types

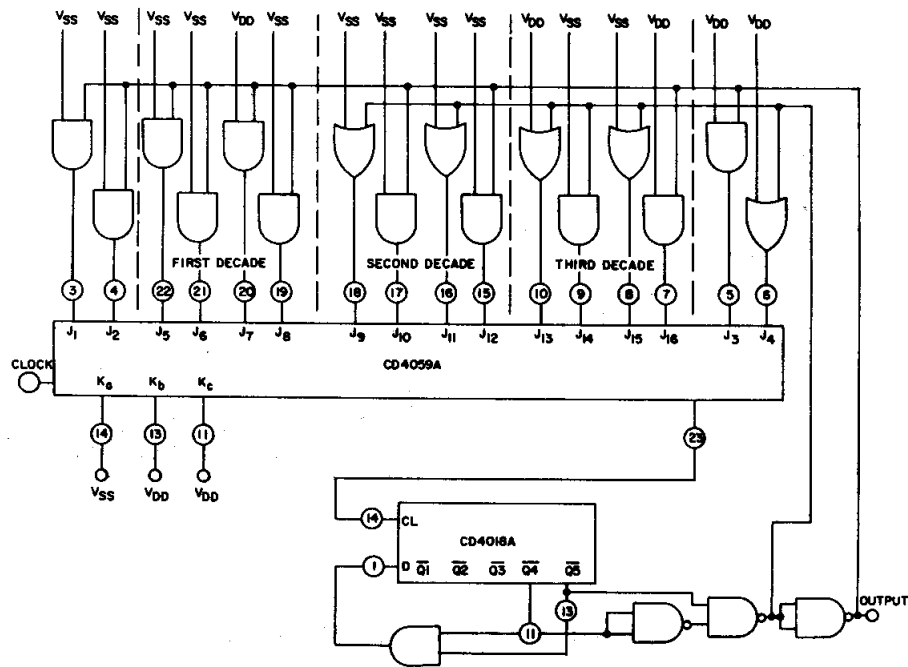

92CL-26947

Fig. 15 — Dividing by any number from 88,003 to 103,999.

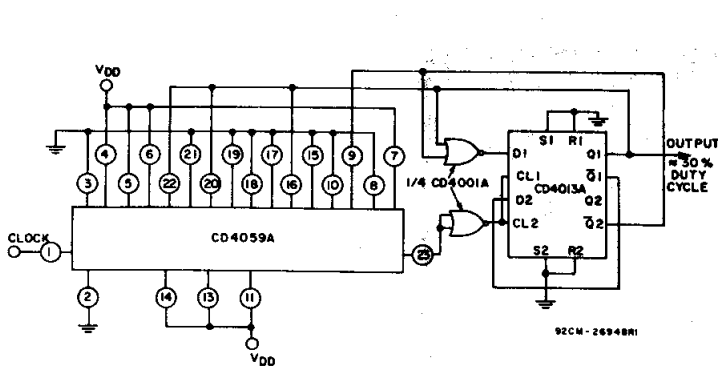

92CM-26948R1

Fig. 16 — Division by 47,690 in  $\div 2$  mode.

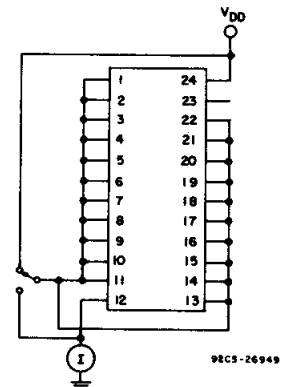

92CS-26949

Fig. 17 — Quiescent device current test circuit.

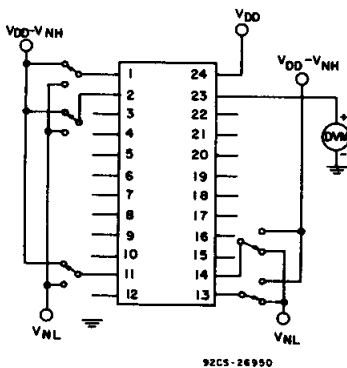

92CS-26950

Fig. 18 — Noise immunity test circuit.

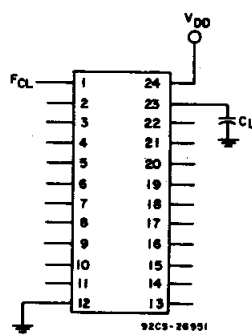

92CS-26951

Fig. 19 — Power dissipation test circuit (all  $\div$  modes).

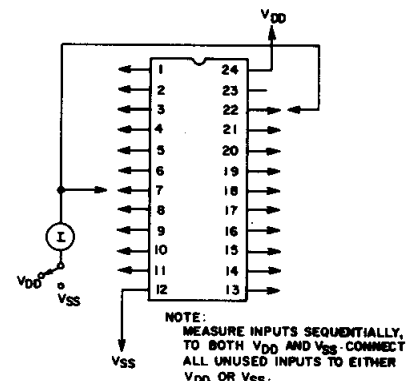

92CS-26952

Fig. 20 — Input leakage current test circuit.

# CD4059A Types

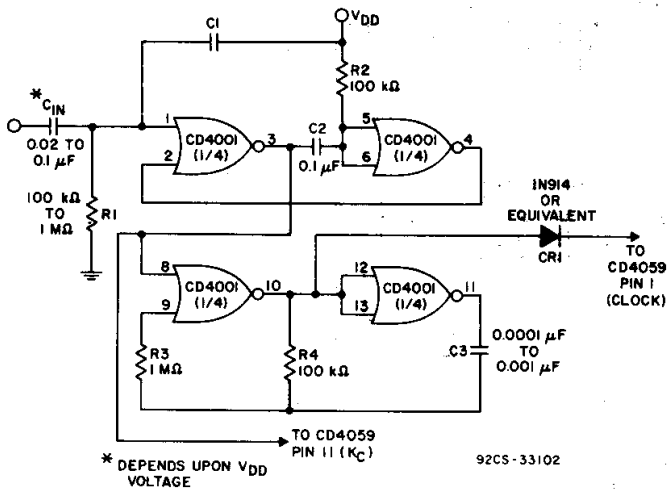

For changing from any mode other than mode 5 (with power on), apply positive pulse to  $C_{in}$ . This circuit automatically selects master preset mode ( $K_a = 0, K_c = 0$ ) before going into the select conditions for mode 5 ( $K_a = 1, K_b = 0, K = 1$ ). The selection of  $C_1$  and  $C_2$  is critical!  $C_1$  is determined by the  $V_{DD}$  voltage--the lower  $V_{DD}$ 's need larger  $C_1$ 's.  $C_2$  must be  $0.1 \mu F$  or larger.

Fig.21 - CD4059A mode 5 power on master preset circuit.

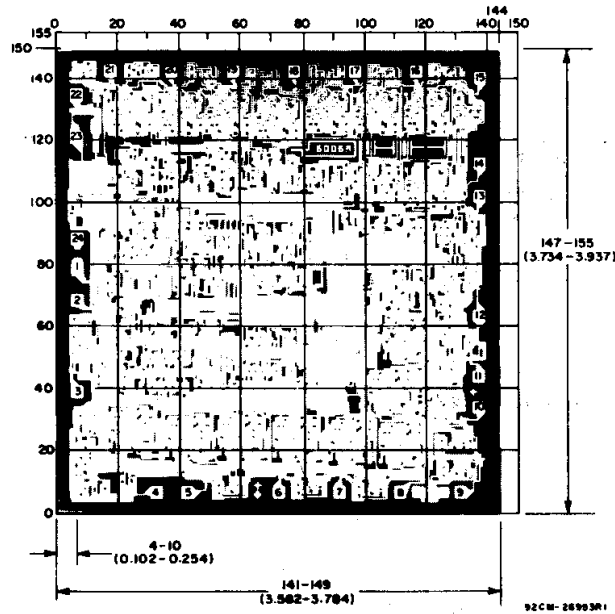

Dimensions in parentheses are in millimeters and are derived from the basic inch dimensions as indicated. Grid graduations are in mils ( $10^{-3}$  inch).

Dimensions and pad layout for CD4059AH.

**PACKAGING INFORMATION**

Orderable Device	Status <sup>(1)</sup>	Package Type	Package Drawing	Pins	Package Qty	Eco Plan <sup>(2)</sup>	Lead/Ball Finish	MSL Peak Temp <sup>(3)</sup>
CD4059AD3	ACTIVE	CDIP SB	JD	24	1	None	Call TI	Level-NC-NC-NC
CD4059AE	ACTIVE	PDIP	N	24	15	Pb-Free (RoHS)	CU NIPDAU	Level-NC-NC-NC
CD4059AM	ACTIVE	SOIC	DW	24	25	Pb-Free (RoHS)	CU NIPDAU	Level-2-250C-1 YEAR/ Level-1-235C-UNLIM
CD4059AM96	ACTIVE	SOIC	DW	24	2000	Pb-Free (RoHS)	CU NIPDAU	Level-2-250C-1 YEAR/ Level-1-235C-UNLIM

<sup>(1)</sup> The marketing status values are defined as follows:

**ACTIVE:** Product device recommended for new designs.

**LIFEBUY:** TI has announced that the device will be discontinued, and a lifetime-buy period is in effect.

**NRND:** Not recommended for new designs. Device is in production to support existing customers, but TI does not recommend using this part in a new design.

**PREVIEW:** Device has been announced but is not in production. Samples may or may not be available.

**OBsolete:** TI has discontinued the production of the device.

<sup>(2)</sup> Eco Plan - May not be currently available - please check <http://www.ti.com/productcontent> for the latest availability information and additional product content details.

**None:** Not yet available Lead (Pb-Free).

**Pb-Free (RoHS):** TI's terms "Lead-Free" or "Pb-Free" mean semiconductor products that are compatible with the current RoHS requirements for all 6 substances, including the requirement that lead not exceed 0.1% by weight in homogeneous materials. Where designed to be soldered at high temperatures, TI Pb-Free products are suitable for use in specified lead-free processes.

**Green (RoHS & no Sb/Br):** TI defines "Green" to mean "Pb-Free" and in addition, uses package materials that do not contain halogens, including bromine (Br) or antimony (Sb) above 0.1% of total product weight.

<sup>(3)</sup> MSL, Peak Temp. -- The Moisture Sensitivity Level rating according to the JEDEC industry standard classifications, and peak solder temperature.

**Important Information and Disclaimer:** The information provided on this page represents TI's knowledge and belief as of the date that it is provided. TI bases its knowledge and belief on information provided by third parties, and makes no representation or warranty as to the accuracy of such information. Efforts are underway to better integrate information from third parties. TI has taken and continues to take reasonable steps to provide representative and accurate information but may not have conducted destructive testing or chemical analysis on incoming materials and chemicals. TI and TI suppliers consider certain information to be proprietary, and thus CAS numbers and other limited information may not be available for release.

In no event shall TI's liability arising out of such information exceed the total purchase price of the TI part(s) at issue in this document sold by TI to Customer on an annual basis.

JD (R-CDIP-T\*\*)

CERAMIC SIDE-BRAZE DUAL-IN-LINE PACKAGE

20 PINS SHOWN

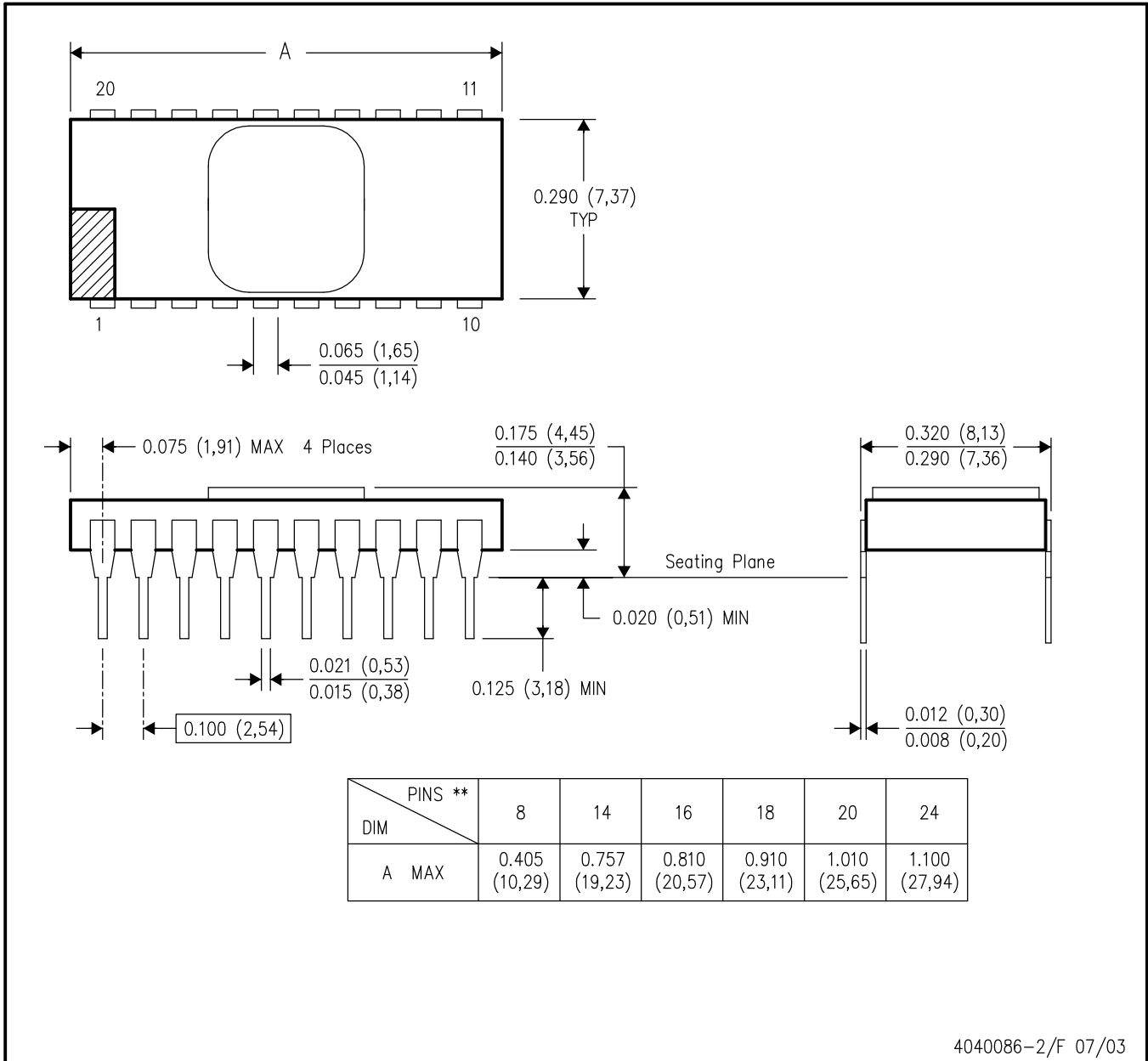

- NOTES:
- A. All linear dimensions are in inches (millimeters).
  - B. This drawing is subject to change without notice.
  - C. This package is hermetically sealed with a metal lid.
  - D. The terminals are gold plated.
  - E. Falls within MIL STD 1835 CDIP2 - T8, T14, T16, T18, T20 and T24 respectively.

JD (R-CDIP-T\*\*)

CERAMIC SIDE-BRAZE DUAL-IN-LINE PACKAGE

24 PINS SHOWN

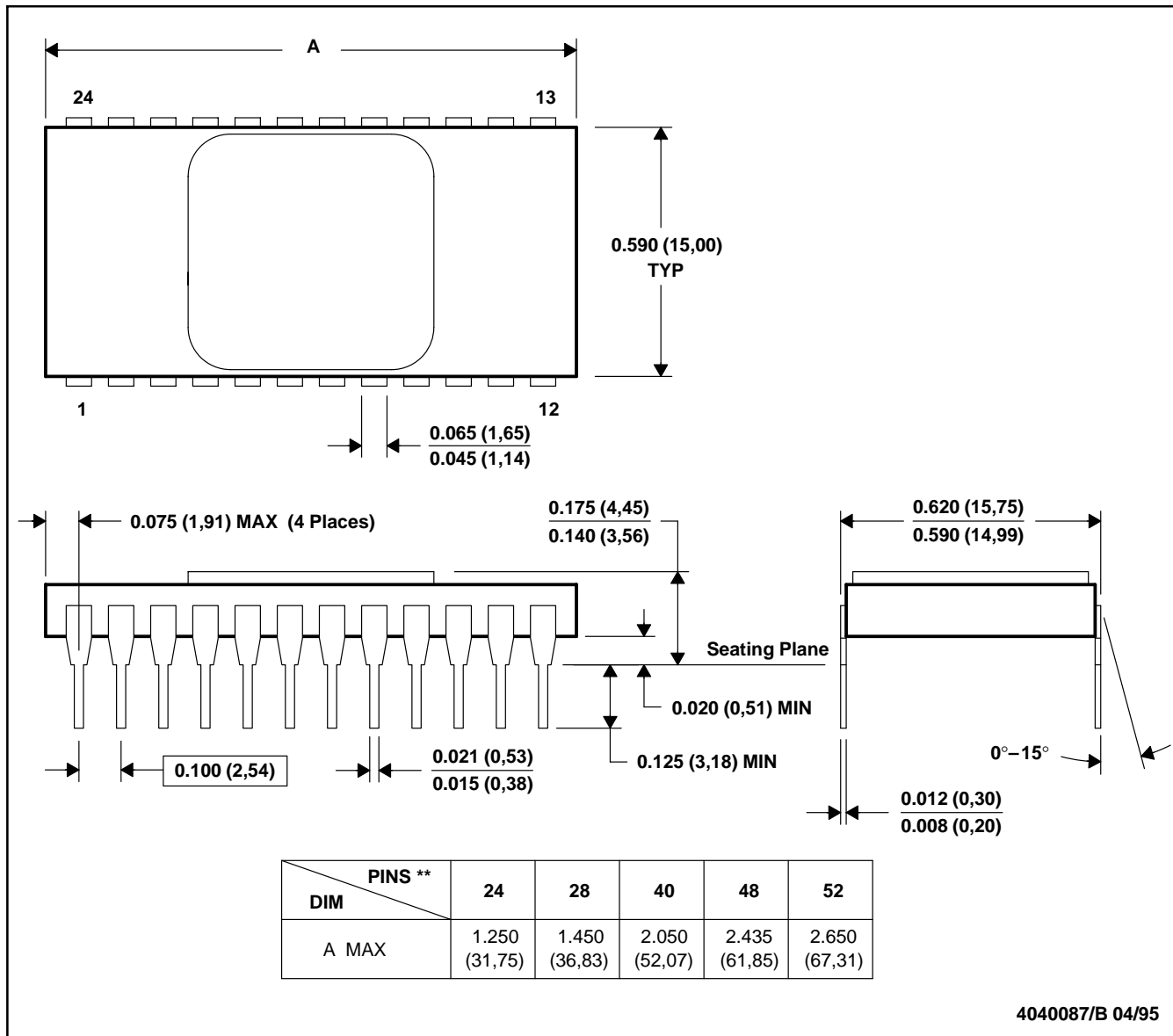

- NOTES: A. All linear dimensions are in inches (millimeters).  
 B. This drawing is subject to change without notice.  
 C. This package is hermetically sealed with a metal lid.  
 D. The terminals are gold-plated.

N (R-PDIP-T24)

PLASTIC DUAL-IN-LINE

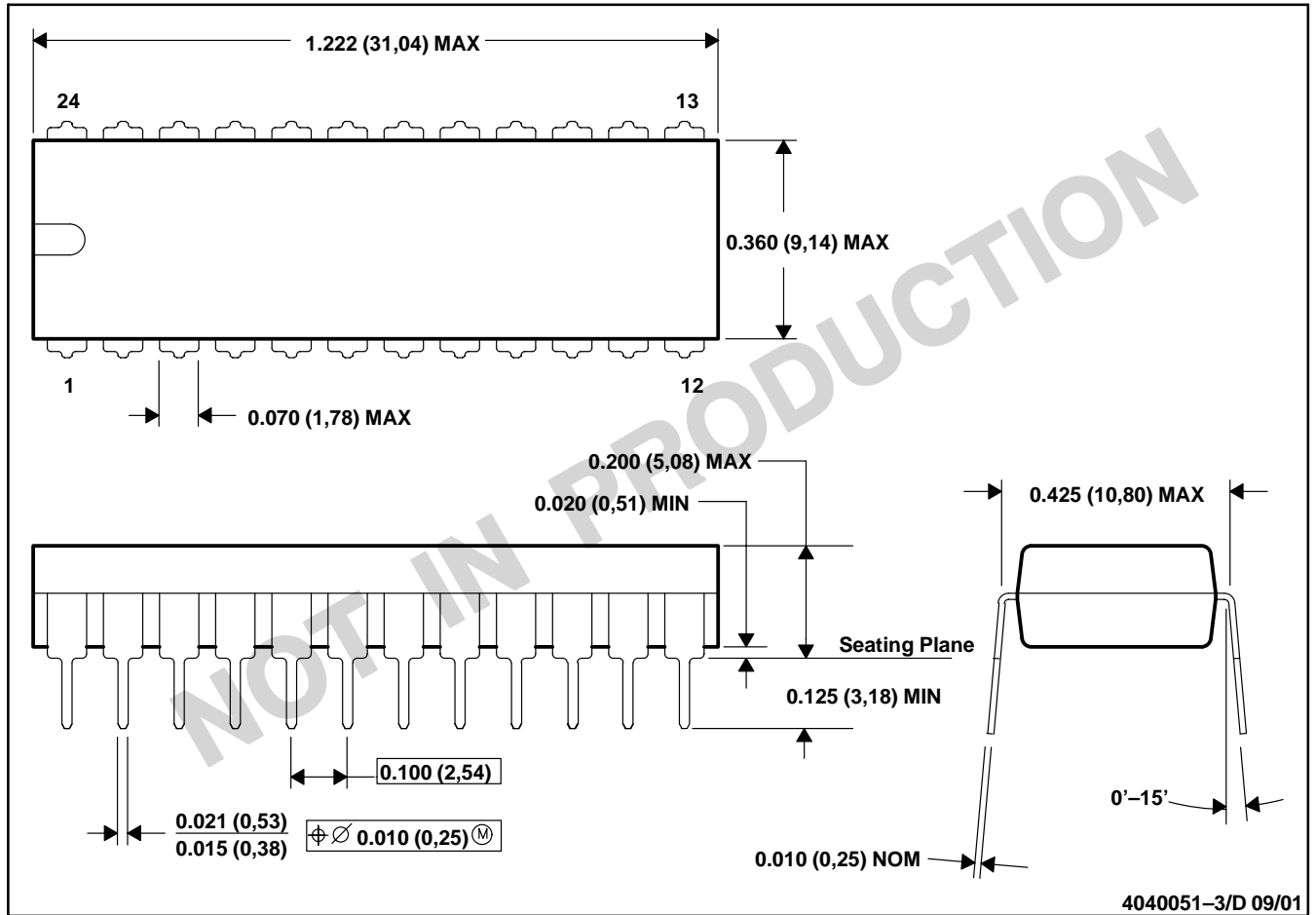

- NOTES: A. All linear dimensions are in inches (millimeters).  
 B. This drawing is subject to change without notice.  
 C. Falls within JEDEC MS-010

N (R-PDIP-T\*\*)

PLASTIC DUAL-IN-LINE PACKAGE

24 PIN SHOWN

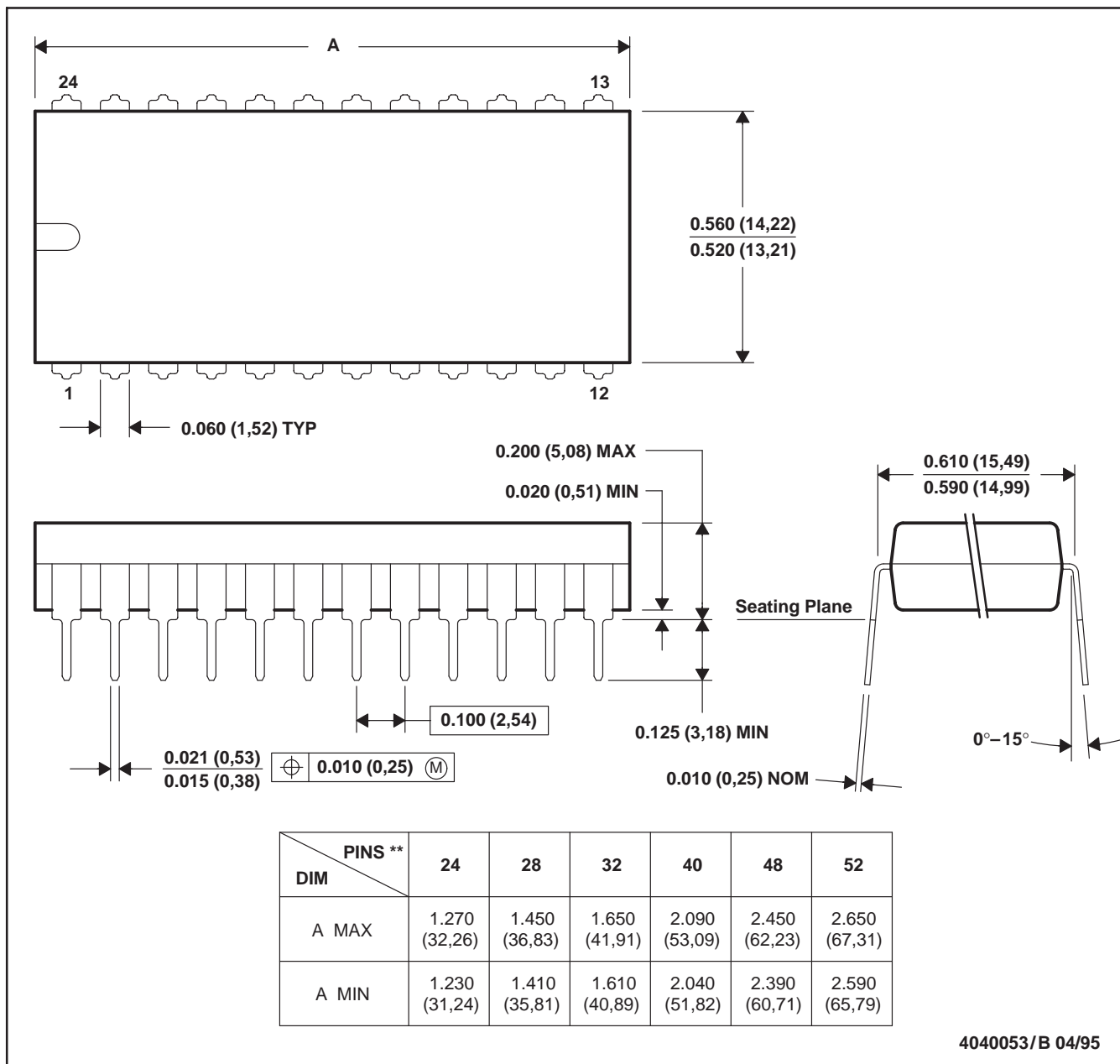

- NOTES: A. All linear dimensions are in inches (millimeters).  
 B. This drawing is subject to change without notice.  
 C. Falls within JEDEC MS-011  
 D. Falls within JEDEC MS-015 (32 pin only)

DW (R-PDSO-G24)

PLASTIC SMALL-OUTLINE PACKAGE

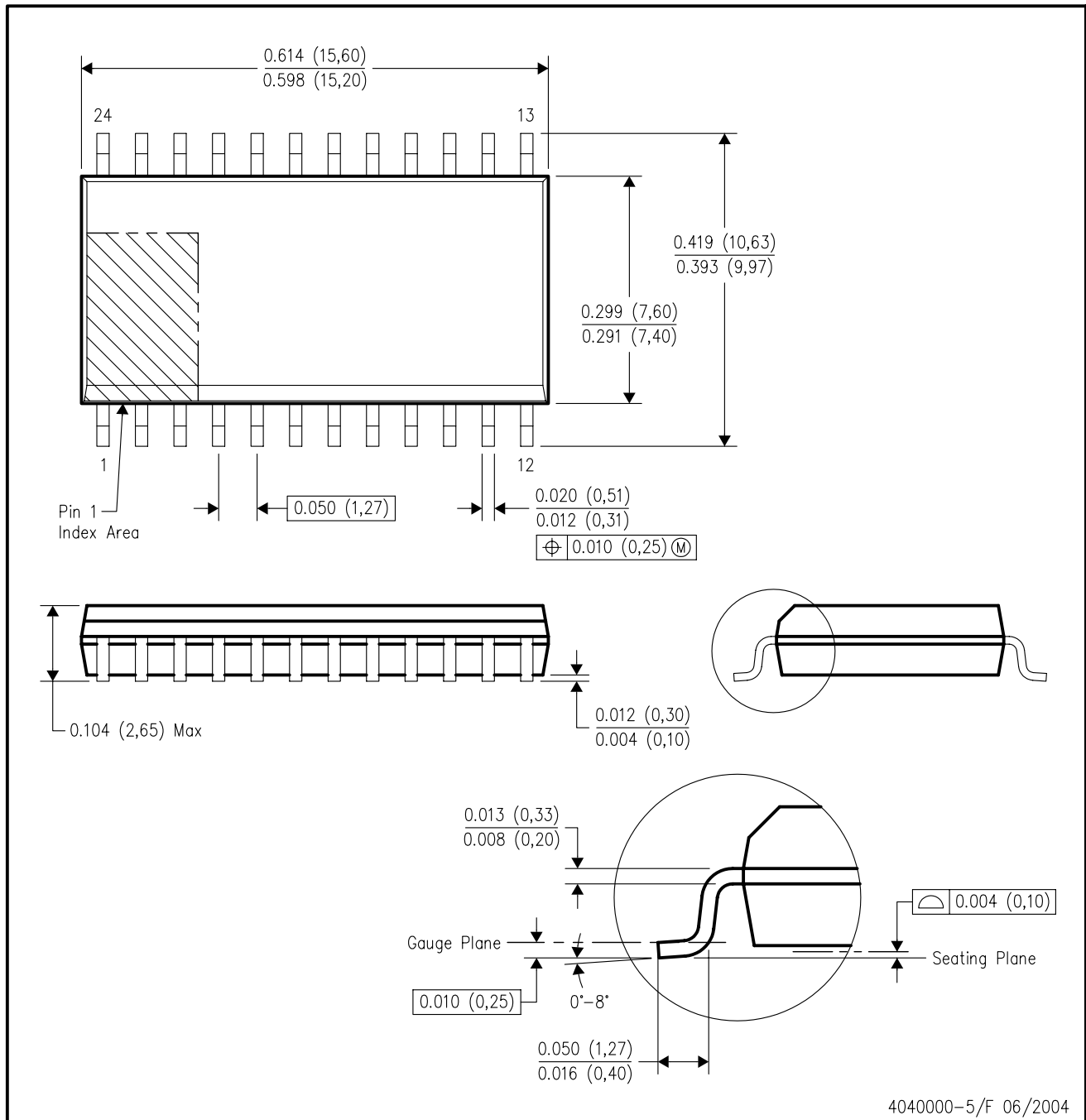

- NOTES:
- A. All linear dimensions are in inches (millimeters).
  - B. This drawing is subject to change without notice.
  - C. Body dimensions do not include mold flash or protrusion not to exceed 0.006 (0,15).
  - D. Falls within JEDEC MS-013 variation AD.

## IMPORTANT NOTICE

Texas Instruments Incorporated and its subsidiaries (TI) reserve the right to make corrections, modifications, enhancements, improvements, and other changes to its products and services at any time and to discontinue any product or service without notice. Customers should obtain the latest relevant information before placing orders and should verify that such information is current and complete. All products are sold subject to TI's terms and conditions of sale supplied at the time of order acknowledgment.

TI warrants performance of its hardware products to the specifications applicable at the time of sale in accordance with TI's standard warranty. Testing and other quality control techniques are used to the extent TI deems necessary to support this warranty. Except where mandated by government requirements, testing of all parameters of each product is not necessarily performed.

TI assumes no liability for applications assistance or customer product design. Customers are responsible for their products and applications using TI components. To minimize the risks associated with customer products and applications, customers should provide adequate design and operating safeguards.

TI does not warrant or represent that any license, either express or implied, is granted under any TI patent right, copyright, mask work right, or other TI intellectual property right relating to any combination, machine, or process in which TI products or services are used. Information published by TI regarding third-party products or services does not constitute a license from TI to use such products or services or a warranty or endorsement thereof. Use of such information may require a license from a third party under the patents or other intellectual property of the third party, or a license from TI under the patents or other intellectual property of TI.

Reproduction of information in TI data books or data sheets is permissible only if reproduction is without alteration and is accompanied by all associated warranties, conditions, limitations, and notices. Reproduction of this information with alteration is an unfair and deceptive business practice. TI is not responsible or liable for such altered documentation.

Resale of TI products or services with statements different from or beyond the parameters stated by TI for that product or service voids all express and any implied warranties for the associated TI product or service and is an unfair and deceptive business practice. TI is not responsible or liable for any such statements.

Following are URLs where you can obtain information on other Texas Instruments products and application solutions:

<b>Products</b>		<b>Applications</b>	
Amplifiers	<a href="http://amplifier.ti.com">amplifier.ti.com</a>	Audio	<a href="http://www.ti.com/audio">www.ti.com/audio</a>
Data Converters	<a href="http://dataconverter.ti.com">dataconverter.ti.com</a>	Automotive	<a href="http://www.ti.com/automotive">www.ti.com/automotive</a>
DSP	<a href="http://dsp.ti.com">dsp.ti.com</a>	Broadband	<a href="http://www.ti.com/broadband">www.ti.com/broadband</a>
Interface	<a href="http://interface.ti.com">interface.ti.com</a>	Digital Control	<a href="http://www.ti.com/digitalcontrol">www.ti.com/digitalcontrol</a>
Logic	<a href="http://logic.ti.com">logic.ti.com</a>	Military	<a href="http://www.ti.com/military">www.ti.com/military</a>
Power Mgmt	<a href="http://power.ti.com">power.ti.com</a>	Optical Networking	<a href="http://www.ti.com/opticalnetwork">www.ti.com/opticalnetwork</a>
Microcontrollers	<a href="http://microcontroller.ti.com">microcontroller.ti.com</a>	Security	<a href="http://www.ti.com/security">www.ti.com/security</a>
		Telephony	<a href="http://www.ti.com/telephony">www.ti.com/telephony</a>
		Video & Imaging	<a href="http://www.ti.com/video">www.ti.com/video</a>
		Wireless	<a href="http://www.ti.com/wireless">www.ti.com/wireless</a>

Mailing Address: Texas Instruments  
Post Office Box 655303 Dallas, Texas 75265

# Texas Instruments

<http://www.ti.com>

This file is the datasheet for the following electronic components:

CD4059A - <http://www.ti.com/product/cd4059a?HQS=TI-null-null-dscatalog-df-pf-null-wwe>

CD4059AD3 - <http://www.ti.com/product/cd4059ad3?HQS=TI-null-null-dscatalog-df-pf-null-wwe>

CD4059AE - <http://www.ti.com/product/cd4059ae?HQS=TI-null-null-dscatalog-df-pf-null-wwe>

CD4059AM - <http://www.ti.com/product/cd4059am?HQS=TI-null-null-dscatalog-df-pf-null-wwe>

CD4059AM96 - <http://www.ti.com/product/cd4059am96?HQS=TI-null-null-dscatalog-df-pf-null-wwe>



LittleDiode supplies new, hard to find or obsolete electronic components and semiconductors all over the world.

With over two million different components listed you are sure to find the part you need.

Feel free to visit us today at our online store:

**[LittleDiode.com](http://LittleDiode.com)**

Looking forward to providing you with the best possible service.