

## CGS2537V Commercial Quad 1 to 4 Clock Drivers

## CGS2537TV Industrial Quad 1 to 4 Clock Drivers

### General Description

These Clock Generation and Support clock drivers are specifically designed for driving memory arrays requiring large fanouts while operating at high speeds.

CGS2537 is a 4 to 16 inverting driver with TTL compatible I/Os. This device features the same characteristics of CGS2534 with an added series resistor on the output for ease of termination while reducing the undershoot.

This device has skew specifications of 350 ps pin-to-pin as well as a 650 ps specification for part-to-part propagation delay variation.

### Features

- Nominal  $8\Omega$  output series resistor
- Guaranteed and tested:
  - 350 ps pin-to-pin skew ( $T_{OSHL}$  and  $T_{OSLH}$ )
  - 650 ps part-to-part variation on positive OR negative transition
- Implemented on National's ABT family process
- Output current drive:
  - $-36\text{ mA} / +20\text{ mA } I_{OH}/I_{OL}$
- Industrial temperature of  $-40^{\circ}\text{C}$  to  $+85^{\circ}\text{C}$
- 28-pin PLCC for optimum skew performance
- Symmetric package orientation
- Large fanout for memory driving applications
- Guaranteed 2 kV ESD protection

### Connection Diagrams

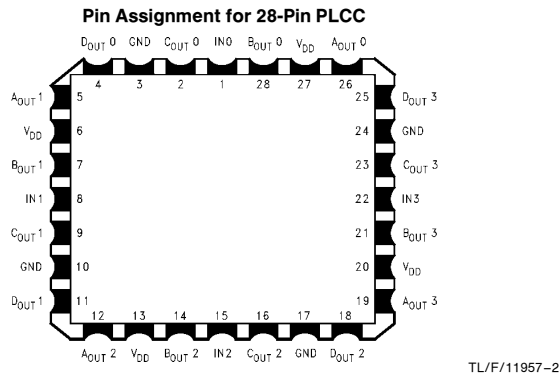

### Truth Table

Input	Output
In (0-3)	$\overline{ABCD}$ Out (0-3)

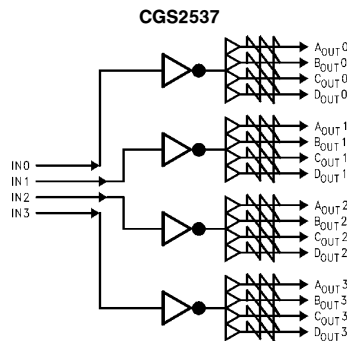

## Absolute Maximum Ratings (Note)

If Military/Aerospace specified devices are required, please contact the National Semiconductor Sales Office/Distributors for availability and specifications.

Supply Voltage ( $V_{CC}$ )	7.0V
Input Voltage ( $V_I$ )	7.0V
Input Current	-30 mA
Current Applied to Output (High/Low)	twice the rated $I_{OH}/I_{OL}$ mA
Storage Temperature Range ( $T_{stg}$ )	-65°C to +150°C
Airflow	Typical $\theta_{JA}$
0 LFM	62°C/W
225 LFM	43°C/W
500 LFM	34°C/W
900 LFM	27°C/W

## Recommended Operating Conditions

Supply Voltage ( $V_{CC}$ )	4.5V to 5.5V
Maximum Input Rise/Fall Time (0.8V to 2.0V)	5 ns
Free Air Operating Temperature	
Industrial	-40°C to +85°C
Commercial	0°C to +70°C

**Note:** The Absolute Maximum Rating are those values beyond which the safety of the device cannot be guaranteed. The device should not be operated at these limits. The parametric values defined in the DC and AC Electrical Characteristics tables are not guaranteed at the absolute maximum ratings. The Recommended Operating Conditions will define the conditions for actual device operation.

## DC Electrical Characteristics

Over recommended operating free air temperature range. All typical values are measured at  $V_{CC} = 5V$ ,  $T_A = 25^\circ C$ .

Symbol	Parameter	Conditions	Min	Typ	Max	Unit
$V_{IL}$	Input Low Level Voltage				0.8	V
$V_{IH}$	Input High Level Voltage		2.0			V
$V_{IK}$	Input Clamp Voltage	$V_{CC} = 4.5V$ , $I_I = -18$ mA			-1.2	V
$V_{OH}$	High Level Output Voltage (Note 5)	$I_{OH} = -3$ mA, $V_{CC} = 4.5V$	2.4			V
		$I_{OH} = -36$ mA, $V_{CC} = 4.5V$	2.0			
$V_{OL}$	Low Level Output Voltage (Note 5)	$V_{CC} = 4.5V$ , $I_{OL} = 20$ mA		0.4	0.5	V
		$V_{CC} = 4.5V$ , $I_{OL} = 50$ $\mu A$		0.1	0.1	
$I_I$	Input Current @ Max Input Voltage	$V_{CC} = 5.5V$ , $V_{IH} = 7V$			7	$\mu A$
$I_{IH}$	High Level Input Current	$V_{CC} = 5.5V$ , $V_{IH} = 2.7V$			5	$\mu A$
$I_{IL}$	Low Level Input Current	$V_{CC} = 5.5V$ , $V_{IL} = 0.4V$	-5			$\mu A$
$I_{OS}$	Output Drive Current	$V_{CC} = 5.5V$ , $V_O = 0V$	-100		275	mA
$I_{OLD}$	Minimum Dynamic Output Current (Note 1)	$V_{CC} = 5.5V$ , $V_{OLD} = 0.8V$	40			mA
$I_{OHD}$	Minimum Dynamic Output Current (Note 1)	$V_{CC} = 5.5V$ , $V_{OHD} = 2.0V$	-55			mA
$I_{CCT}$	Maximum $I_{CC}$ /Input	$V_{CC} = 5.5V$			3.6	mA
$I_{CC}$	Supply Current '2537 (Quiescent)	$V_{CC} = 5.5V$			235	$\mu A$
$C_{IN}$	Input Capacitance	$V_{CC} = 5V$		5		pF

**Note 1:** Maximum test duration 2.0 ms, one output loaded at a time.

## AC Electrical Characteristics

Over recommended operating conditions unless otherwise specified. All typical values are measured at  $V_{CC} = 5V$ ,  $T_A = 25^\circ C$ .

Symbol	Parameter	CGS2537						Units
		$T_A = +25^\circ C$ $C_L = 50\text{ pF}, R_L = 500\Omega$			$T_A = -40\text{ to }+85^\circ C$ $C_L = 50\text{ pF}, R_L = 500\Omega$			
		Min	Typ	Max	Min	Typ	Max	
$f_{max}$	Frequency Maximum					125		MHz
$t_{PLH}$	Low-to-High Propagation Delay $I_{N_n}$ to $O_{U_n}$			3.75			3.75	ns
$t_{PHL}$	High-to-Low Propagation Delay $I_{N_n}$ to $O_{U_n}$			3.75			3.75	ns
$t_{OSHL}$	Maximum Skew Common Edge Output-to-Output Variation (Note 2)		150	350		300	350	ps
$t_{OSLH}$	Maximum Skew Common Edge Output-to-Output Variation (Note 2)		150	350		300	350	ps
$t_{rise}$ , $t_{fall}$	Rise/Fall Time (from 0.8V/2.0V to 2.0V/0.8V)			1.7			1.7	ns
$t_{HIGH}$ $t_{LOW}$	Pulse Width Duration High Pulse Width Duration Low	4			4			ns
$t_{PVLH}$	Part-to-Part Variation of Low-to-High Transitions (Note 3)			650			650	ps
$t_{PVHL}$	Part-to-Part Variation of High-to-Low Transitions (Note 3)			650			650	ps

**Note 2:** Output-to-Output Skew is defined as the absolute value of the difference between the actual propagation delay for any outputs within the same packaged device. The specifications apply to any outputs switching in the same direction either HIGH to LOW ( $t_{OSHL}$ ) or LOW to HIGH ( $t_{OSLH}$ ). Limits are guaranteed by design.

**Note 3:** Part to Part transition variation is defined as the absolute difference between the propagation delay of any output on one device to any output on another device. The specifications apply to any outputs switching in the same direction either HIGH to LOW ( $t_{PVHL}$ ) or LOW to HIGH ( $t_{PVLH}$ ). Limits are guaranteed by design.

**Note 4:** Time high is measured at 2.0V, Time low is measured at 0.8V.

**Note 5:** For increased output drive, output pins may be connected together when the corresponding input pins are connected together.

### Timing Information

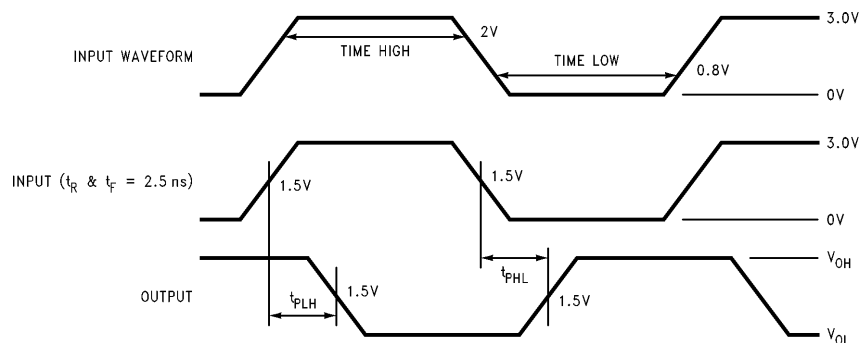

TL/F/11957-4

## CGS2534/35/36/37

### Memory Array Driving

In order to minimize the total load on the address bus, quite often memory arrays are being driven by buffers while having the inputs of the buffers tied together. Although this practice was feasible in the conventional memory designs, in today's high speed, large buswidth designs which require address fetching at higher speeds, this technique produces many undesired results such as cross-talk and over/undershoot.

CGS2534/35/36/37 Quad 1 to 4 Clock Drivers were designed specifically to address these application issues on high speed, large memory arrays systems.

These drivers are optimized to driver large loads, with 3.5 ns propagation delays. These drivers produce less noise while reducing the total capacitive loading on the address bus by having only four inputs tied together (see the diagram below, point A). This helps to minimize the overshoot and undershoot by having only four outputs being switched simultaneously.

Also this larger fan-out helps to save board space since for every one of these drivers, two conventional buffers were typically being used.

Another feature associated with these clock drivers is a 250 ps–500 ps pin-to-pin skew specification. The minimum skew specification allows high speed memory system designers to optimize the performance of their memory subsystem by operating at higher frequencies without having concerns about output-to-output (bank-to-bank) synchronization problem which are associated with driving high capacitive loads (Point B).

The diagram below depicts a "2534/35/36/37" a memory subsystem operating at high speed with large memory capacity. The address bus is common to both the memory and the CPU and I/Os.

These drivers can operate beyond 150 MHz, and are also available in 3V–5V TTL/CMOS versions with large current drive .

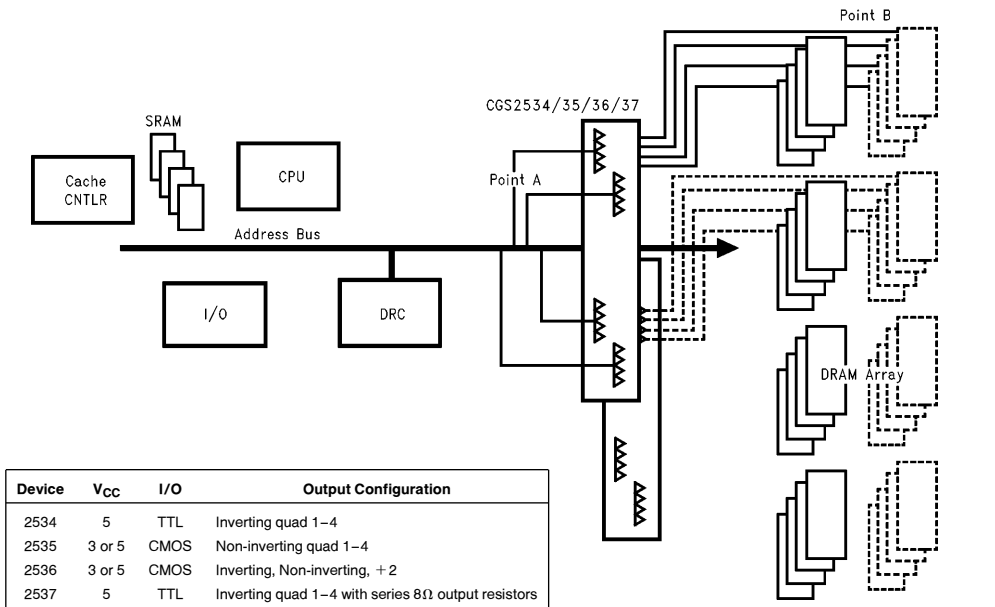

TL/F/11957–5

**Ordering Information** (Contact NSC Marketing for specific date of availability)

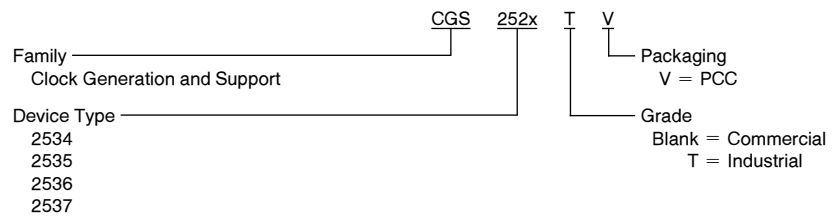

**CGS2537V Commercial Quad 1 to 4 Clock Drivers**  
**CGS2537TV Industrial Quad 1 to 4 Clock Drivers**

**Physical Dimensions** inches (millimeters)

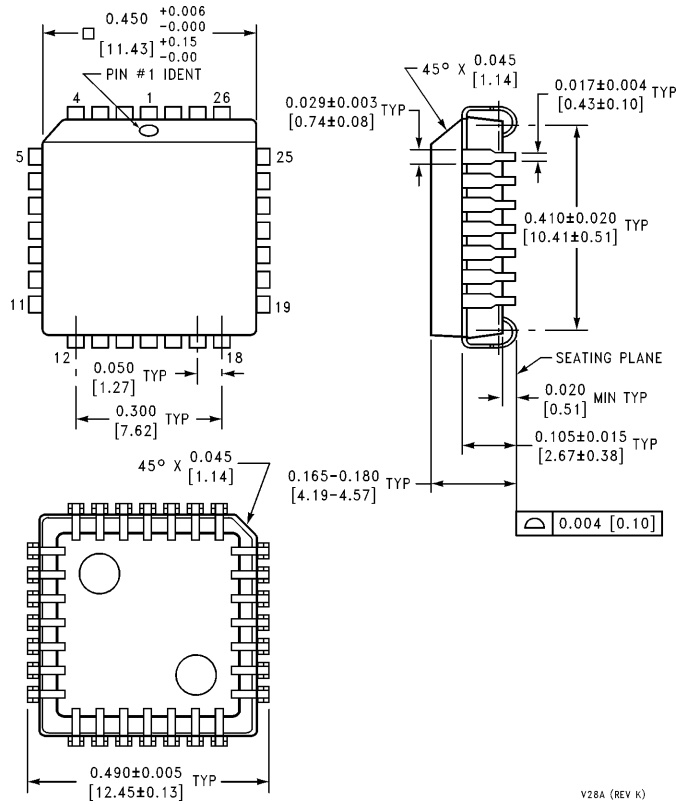

**28-Lead Molded Plastic Leaded Chip Carrier**  
**Order Number CGS2537V, CGS2537TV**  
**NS Package Number V28A**

V28A (REV K)

**LIFE SUPPORT POLICY**

NATIONAL'S PRODUCTS ARE NOT AUTHORIZED FOR USE AS CRITICAL COMPONENTS IN LIFE SUPPORT DEVICES OR SYSTEMS WITHOUT THE EXPRESS WRITTEN APPROVAL OF THE PRESIDENT OF NATIONAL SEMICONDUCTOR CORPORATION. As used herein:

1. Life support devices or systems are devices or systems which, (a) are intended for surgical implant into the body, or (b) support or sustain life, and whose failure to perform, when properly used in accordance with instructions for use provided in the labeling, can be reasonably expected to result in a significant injury to the user.
2. A critical component is any component of a life support device or system whose failure to perform can be reasonably expected to cause the failure of the life support device or system, or to affect its safety or effectiveness.



**National Semiconductor Corporation**  
 1111 West Bardin Road  
 Arlington, TX 76017  
 Tel: 1(800) 272-9959  
 Fax: 1(800) 737-7018

**National Semiconductor Europe**  
 Fax: (+49) 0-180-530 85 86  
 Email: onjwge@tevm2.nsc.com  
 Deutsch Tel: (+49) 0-180-530 85 85  
 English Tel: (+49) 0-180-532 78 32  
 Français Tel: (+49) 0-180-532 93 58  
 Italiano Tel: (+49) 0-180-534 16 80

**National Semiconductor Hong Kong Ltd.**  
 19th Floor, Straight Block,  
 Ocean Centre, 5 Canton Rd.  
 Tsimshatsui, Kowloon  
 Hong Kong  
 Tel: (852) 2737-1600  
 Fax: (852) 2736-9960

**National Semiconductor Japan Ltd.**  
 Tel: 81-043-299-2309  
 Fax: 81-043-299-2408

National does not assume any responsibility for use of any circuitry described, no circuit patent licenses are implied and National reserves the right at any time without notice to change said circuitry and specifications.

# National Semiconductor was acquired by Texas Instruments.

[http://www.ti.com/corp/docs/investor\\_relations/pr\\_09\\_23\\_2011\\_national\\_semiconductor.html](http://www.ti.com/corp/docs/investor_relations/pr_09_23_2011_national_semiconductor.html)

This file is the datasheet for the following electronic components:

CGS2537TV - <http://www.ti.com/product/cgs2537tv?HQS=TI-null-null-dscatalog-df-pf-null-ww>

CGS2537V - <http://www.ti.com/product/cgs2537v?HQS=TI-null-null-dscatalog-df-pf-null-ww>



LittleDiode supplies new, hard to find or obsolete electronic components and semiconductors all over the world.

With over two million different components listed you are sure to find the part you need.

Feel free to visit us today at our online store:

[LittleDiode.com](http://LittleDiode.com)

Looking forward to providing you with the best possible service.