

GaAs MMIC

CGY 21

- Two-stage monolithic microwave IC (MMIC amplifier)
- All gold metallization
- Chip fully passivated
- Operating voltage range: 3 to 6 V
- 50Ω input/output; $RL_{IN} RL_{OUT} > 10 \text{ dB}$
- Gain: 21 dB at 500 MHz
- Low noise figure: 3.9 dB at 500 MHz
- Bandwidth: 2 GHz
- Hermetically sealed package

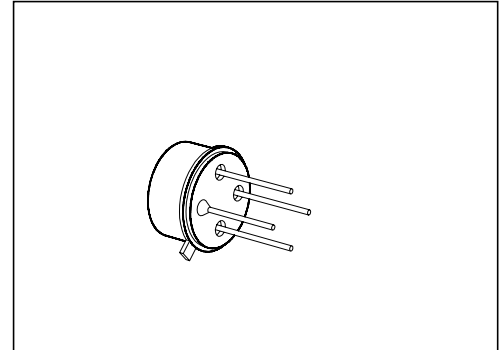

ESD: Electrostatic discharge sensitive device, observe handling precautions!

Type	Ordering Code	Circuit Diagram (Pin Configuration)	Package ¹⁾
CGY 21	Q68000-A5953	<p>1 RF output, V_S 2 Interstage, V_S 3 RF input 4 RF and DC ground, case</p> <p>EHA07017</p>	TO-12

¹⁾ For detailed information see chapter Package Outlines.

Maximum Ratings

Parameter	Symbol	Values	Unit
Supply voltage, $T_c \leq 80 \text{ }^\circ\text{C}$	V_S	6	V
Total power dissipation, $T_c \leq 50 \text{ }^\circ\text{C}$	P_{tot}	2	W
Channel temperature	T_{ch}	150	°C
Storage temperature range	T_{stg}	- 55 ... + 150	

Thermal Resistance

Channel - case	R_{thchC}	50	K/W
----------------	--------------------	----	-----

Note: Exceeding any of the maximum ratings may cause permanent damage to the device. Appropriate handling procedures are required to protect the electrostatic sensitive IC against degradation due to excess voltage or excess current spikes. Excellent ground connection of lead 4 and the package (e. g. soldered on microstripline laminate) is required to achieve guaranteed RF performance and stable operation conditions and provides adequate heat sink. Low parasitic capacitance of the bias network to port 2 gives optimum gain and flatness. Input and output connections must be DC isolated by coupling capacitors.

Electrical Characteristics

at $T_A = 25\text{ °C}$, $V_S = 4.5\text{ V}$, $R_S = R_L = 50\text{ }\Omega$, unless otherwise specified,
(for application circuit see next page).

Parameter	Symbol	Values			Unit
		min.	typ.	max.	
Operating current	I_{op}	–	160	200	mA
Power gain $f = 100\text{ MHz to }900\text{ MHz}$	G	19	21	–	dB
Gain flatness $f = 100\text{ MHz to }900\text{ MHz}$	ΔG	–	1.5	2	
Noise figure $f = 100\text{ MHz to }900\text{ MHz}$	F	–	3.9	5.5	
Input return loss $f = 100\text{ MHz to }900\text{ MHz}$	RL_{IN}	–	12	9.5	
Output return loss $f = 100\text{ MHz to }900\text{ MHz}$	RL_{OUT}	–	12	9.5	
Third order intercept point two-tone intermodulation test $f = 806\text{ MHz}$, $f = 810\text{ MHz}$, $P_o = 10\text{ dBm}$ (both carriers)	IP_3	31	32.5	–	dBm
1 dB gain compression $f = 100\text{ MHz to }900\text{ MHz}$	P_{1dB}	–	19	–	

Application Circuit

$f = 100 \text{ MHz to } 900 \text{ MHz}$

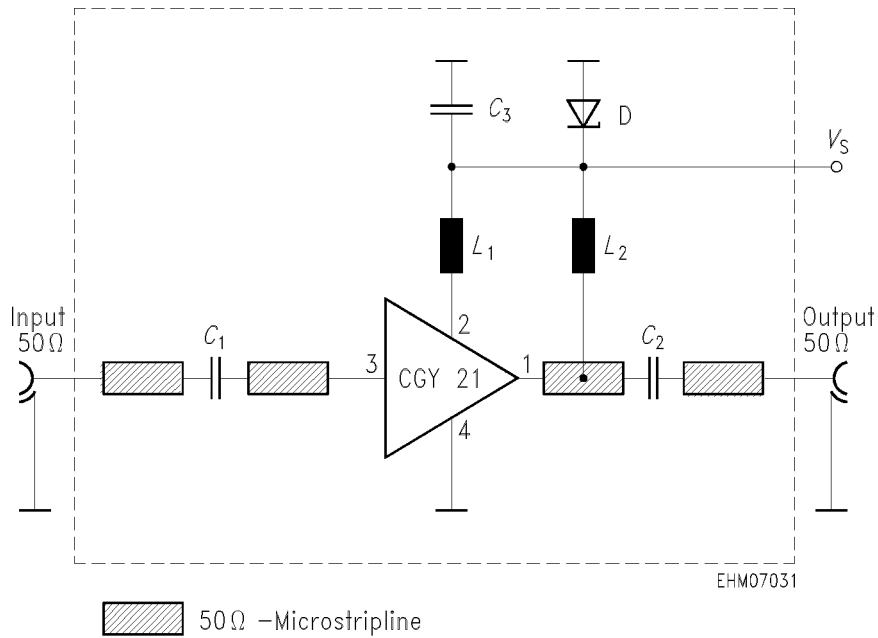

Legend of components

C_1, C_2, C_3	1 nF chip capacitors
L_1, L_2	1 μH inductance (B 78108 - T 1102K)
D	6 V2 Zener diode (BZW 22C6V2)

Total power dissipation $P_{tot} = f(T_c)$

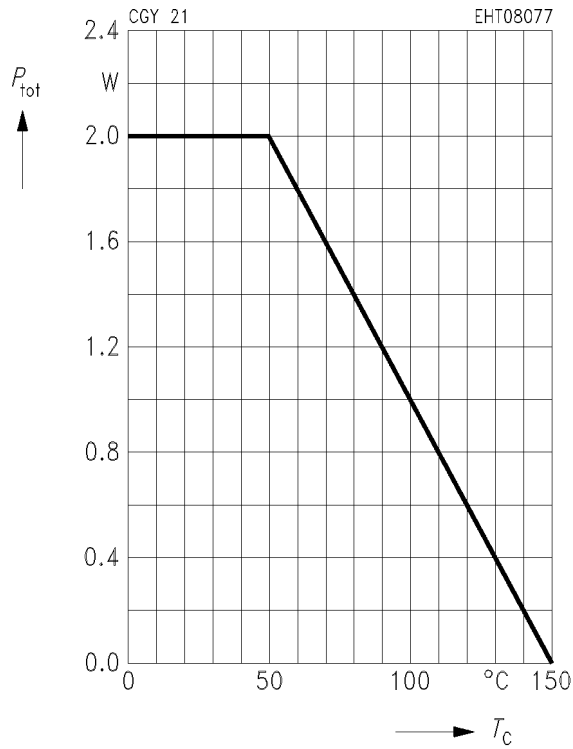

Max. supply voltage $V_{Smax} = f(T_c)$

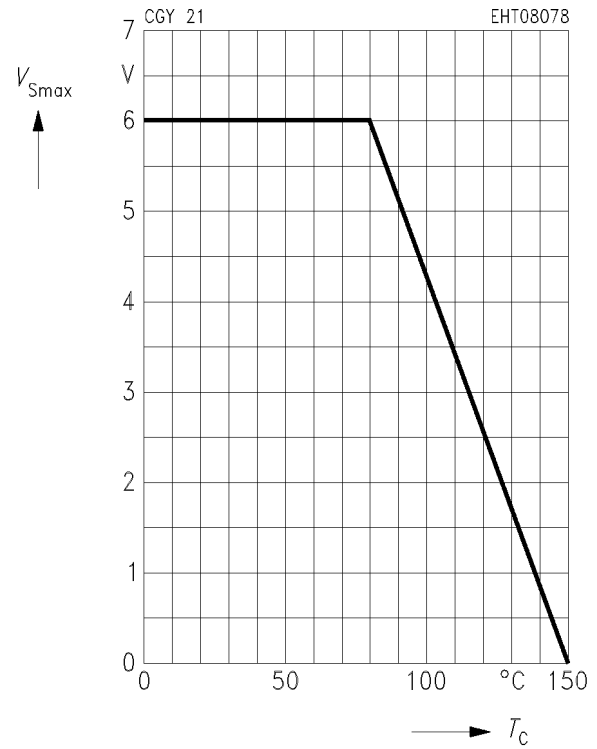

Operating current $I_{op} = f(V_s)$

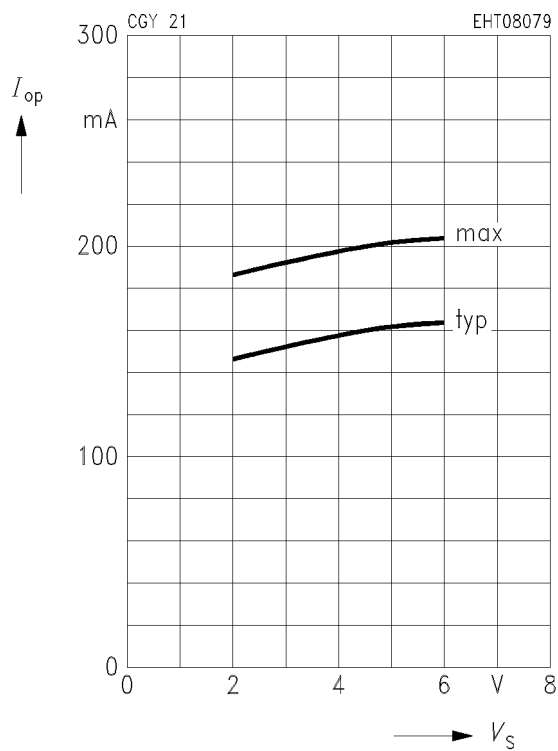

Power gain $G = f(f)$

$V_s = 4.5 \text{ V}$, $R_s = R_L = 50 \Omega$

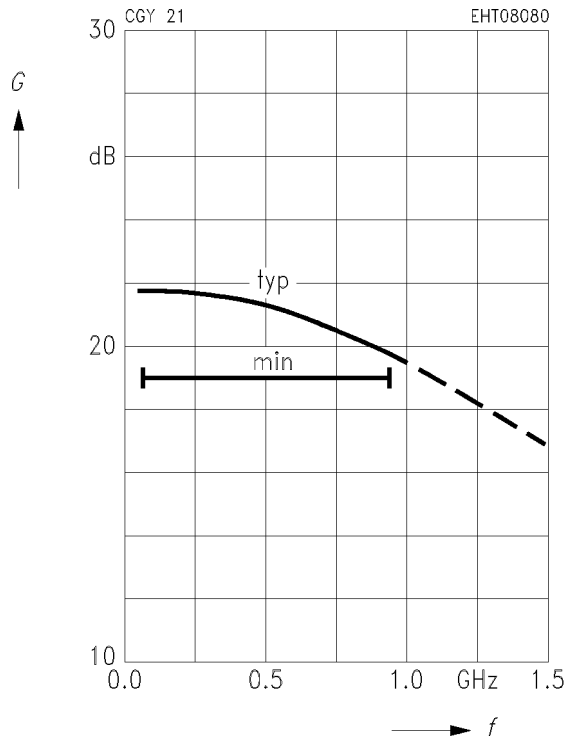

Power gain $G = f(V_s)$

$R_s = R_L = 50 \Omega$

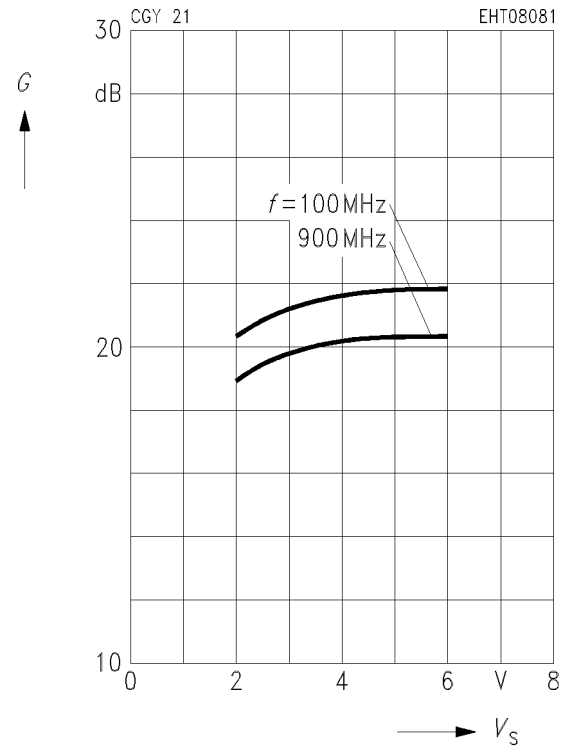

Power gain $G = f(P_{out})$

$V_s = 4.5 \text{ V}$, $R_s = R_L = 50 \Omega$

$f = 0.8 \text{ GHz}$

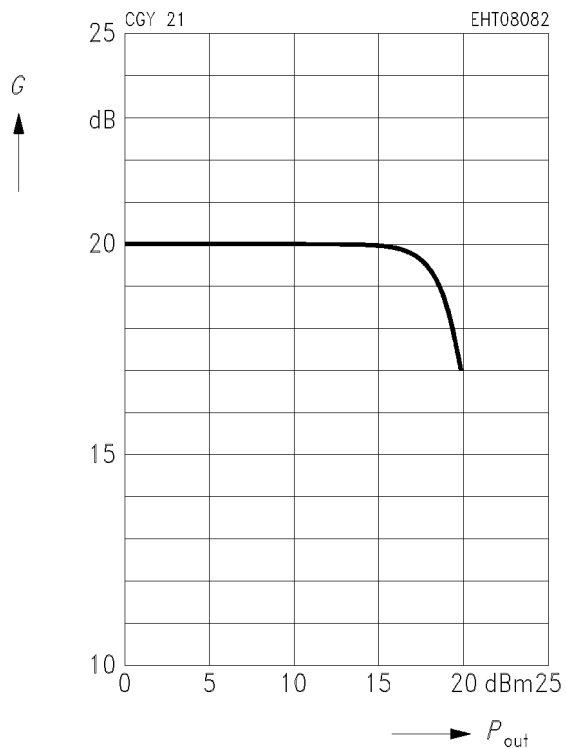

Third order intercept point $IP_3 = f(V_S)$

$f = 800 \text{ MHz}$, $R_S = R_L = 50 \Omega$

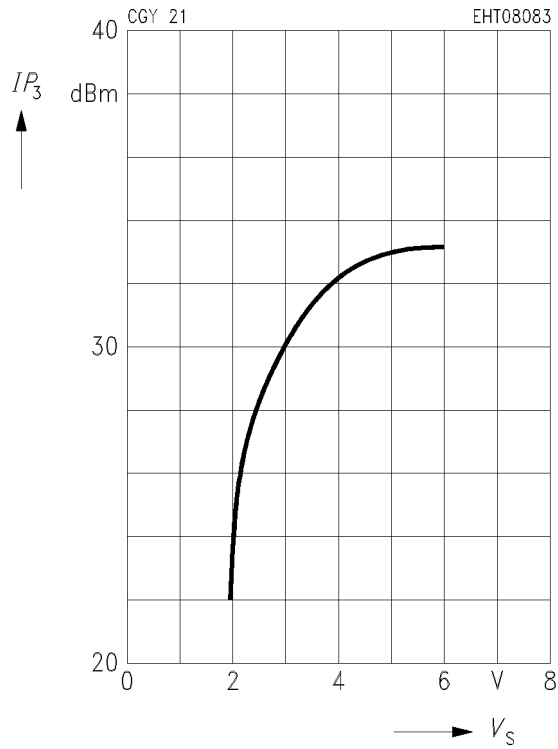

Noise figure $F = f(V_S)$

$R_S = R_L = 50 \Omega$

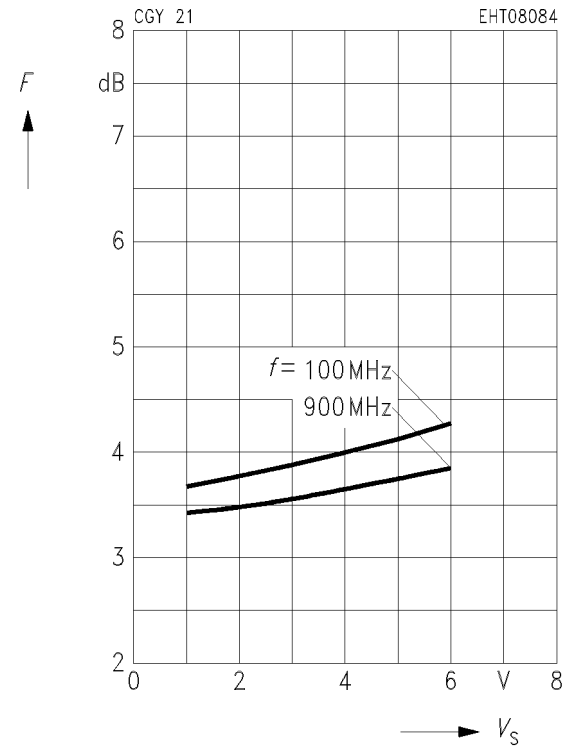

Noise figure $F = f(f)$

$V_S = 4.5 \text{ V}$, $R_S = R_L = 50 \Omega$

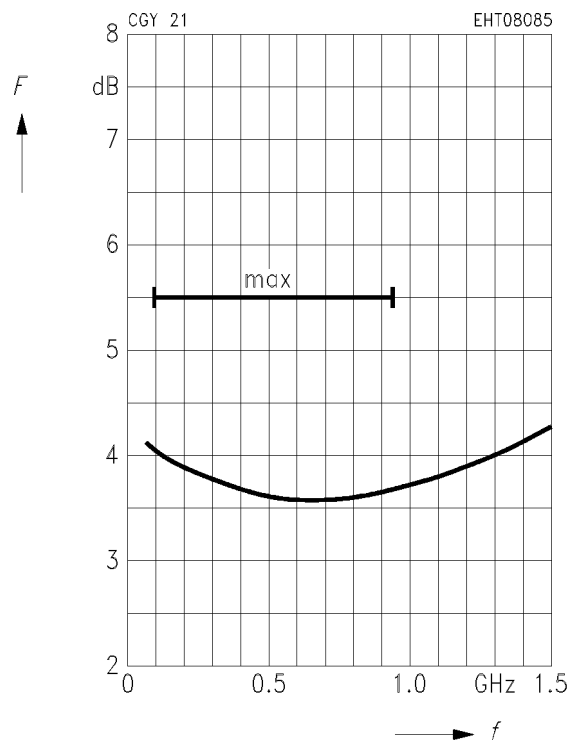

S Parameters

f	S_{11}		S_{21}		S_{12}		S_{22}	
GHz	MAG	ANG	MAG	ANG	MAG	ANG	MAG	ANG
$V_s = 4.5 \text{ V}, Z_0 = 50 \Omega$								
0.1	0.02	49	13.82	- 10	0.012	- 2	0.11	3
0.3	0.08	55	13.63	- 34	0.012	- 7	0.13	11
0.5	0.14	34	13.03	- 58	0.012	- 13	0.15	18
0.7	0.18	17	12.1	- 81	0.011	- 19	0.19	20
0.9	0.23	0	10.93	- 104	0.011	- 24	0.24	20
1.1	0.27	- 15	9.48	- 127	0.01	- 29	0.29	16
1.3	0.28	- 28	7.91	- 149	0.009	- 31	0.33	12
1.5	0.25	- 39	6.29	- 171	0.008	- 32	0.36	5

$$S_{11} = f(f)$$

$V_s = 4.5 \text{ V}, Z_0 = 50 \Omega$

$$S_{12} = f(f)$$

$V_s = 4.5 \text{ V}, Z_0 = 50 \Omega$

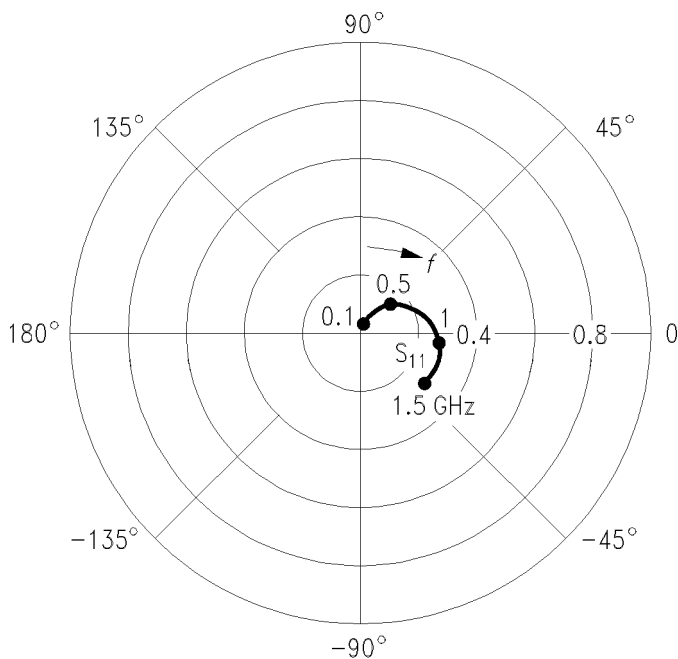

EHT08086

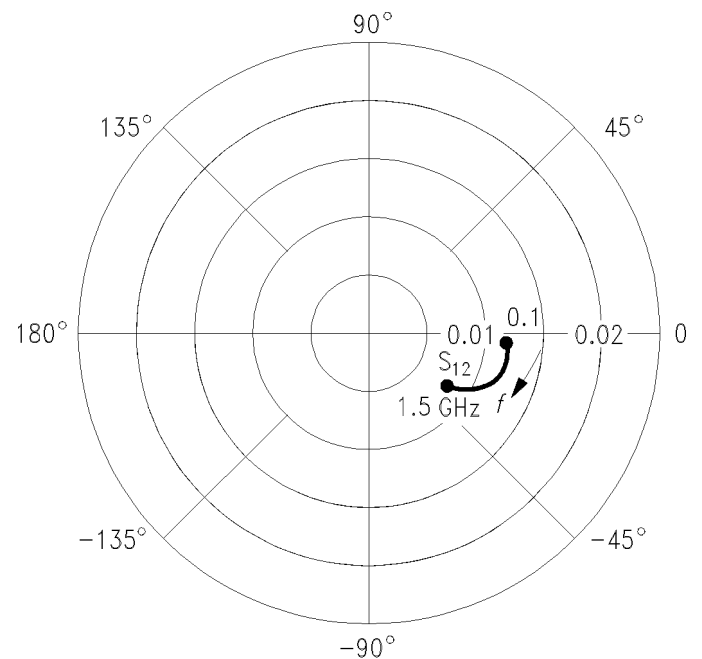

EHT08087

S Parameters (continued)

$$S_{21} = f(f)$$

$V_s = 4.5 \text{ V}, Z_0 = 50 \Omega$

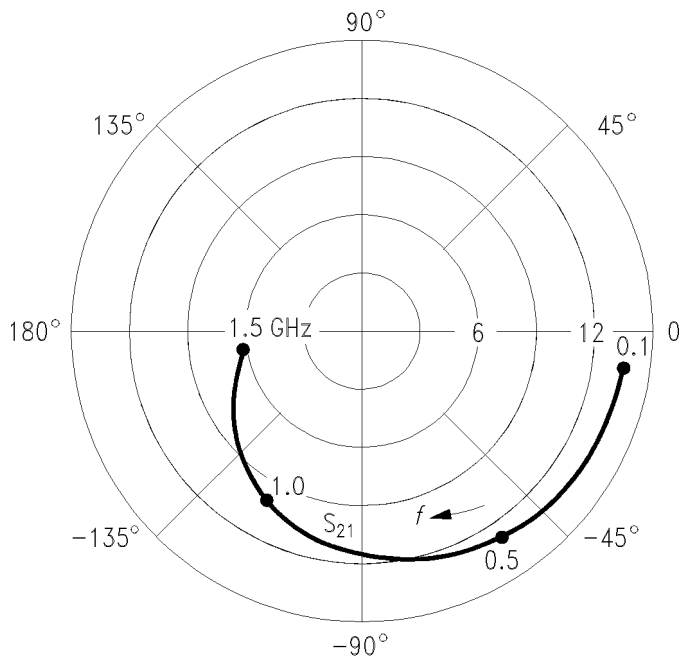

EHT08088

$$S_{22} = f(f)$$

$V_s = 4.5 \text{ V}, Z_0 = 50 \Omega$

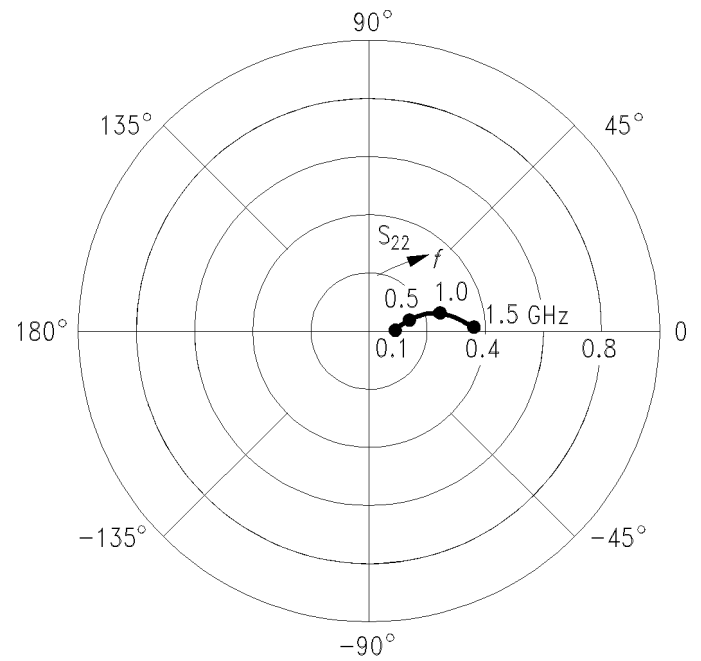

EHT08089



LittleDiode supplies new, hard to find or obsolete electronic components and semiconductors all over the world.

With over two million different components listed you are sure to find the part you need.

Feel free to visit us today at our online store:

LittleDiode.com

Looking forward to providing you with the best possible service.