

Datasheet

- * Single-stage monolithic microwave IC (MMIC-amplifier)
- * Application range: 100 MHz to 3 GHz
- * Gain: 9 dB typ. @ 1.6 GHz
- * Low noise figure: 2.7 dB typ. @ 1.6 GHz
- * Bandwidth: 3 GHz typ. @ -3 dB, VSWR < 2 : 1
- * Operating voltage range: 3 to 5.5 V
- * Individual current control with neg. gate bias
- * Hermetically sealed ceramic stripline package Cerec-X

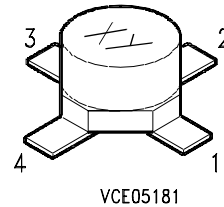

ESD: Electrostatic discharge sensitive device, observe handling precautions!

Type	Marking	Ordering code (tape and reel)	Circuit Diagram (Pin Configuration)	Package 1)
CGY 40	40	Q68000-A4444		Cerec-X

Maximum ratings	Symbol	Value	Unit
Drain-voltage	V_D	5.5	V
Current control gate voltage	V_G	-3 ... 0	V
Drain-gate voltage	V_{DG}	8.5	V
Input power	P_{IN}	16	dBm
Channel temperature	T_{Ch}	150	°C
Storage temperature range	T_{stg}	-55...+150	°C
Total power dissipation ($T_S \leq 82^\circ\text{C}$) 2)	P_{tot}	440	mW
Thermal resistance			
Channel-soldering point 2)	R_{thChS}	155	K/W

Note: Exceeding any of the max. ratings may cause permanent damage to the device. Appropriate handling is required to protect the electrostatic sensitive MMIC against degradation due to excess voltage or current spikes. Proper ground connection of leads 2 and 4 (with min. inductance) is required to achieve the guaranteed RF performance, stable operating conditions and adequate cooling.

- 1) Dimensions see chapter Package Outlines
- 2) T_s is measured on the source lead at the soldering point to the PCB.

Electrical Characteristics

$T_A = 25\text{ °C}$, $V_G = 0\text{ V}$, $V_D = 4.5\text{ V}$, $R_S = R_L = 50\text{ }\Omega$, unless otherwise specified
(for application circuit see next page)

Characteristics	Symbol	min	typ	max	Unit
Drain current	I_D	-	60	80	mA
Power gain f = 200 MHz f = 1800 MHz	G	9.5 8	10.5 9	12 10.5	dB
Gain flatness f = 200 to 1000 MHz f = 800 to 1800 MHz	ΔG	- -	0.4 1.1	- 2	dB
Noise figure f = 200 to 1000 MHz f = 800 to 1800 MHz	F	- -	2.5 2.8	- 4.0	dB
Input return loss f = 200 to 1000 MHz f = 800 to 1800 MHz	RL_{IN}	- -	13 12	- 9.5	dB
Output return loss f = 200 to 1000 MHz f = 800 to 1800 MHz	RL_{OUT}	- -	12 12	- 9.5	dB
Third order intercept point Two tone intermodulation test f ₁ = 806 MHz, f ₂ = 810 MHz P ₀ = 10 dBm (both carriers)	$IP3$	31	32	-	dBm
1dB gain compression f = 200 to 1800 MHz	$P_{1\text{ dB}}$	-	18	-	dBm
Gain control dynamic range f = 200 to 1000 MHz f = 800 to 1800 MHz	ΔG	- -	30 20	- -	dB

Application Circuit (f = 800 to 1800 MHz)

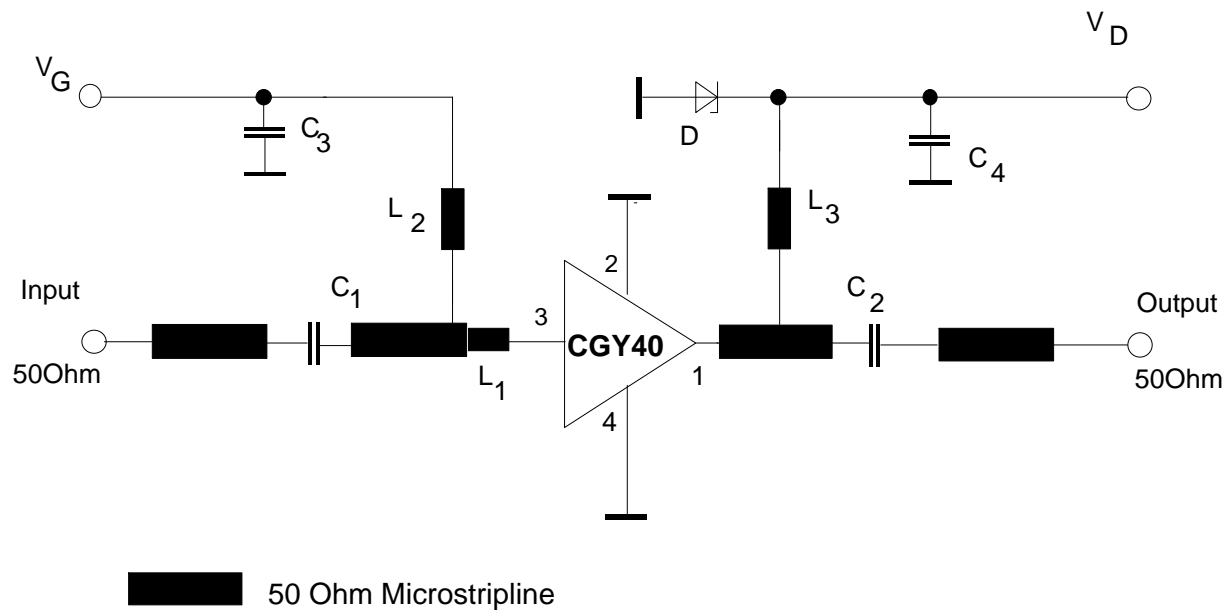

Legend of components

C_1, C_2	Chip capacitors 100 pF
C_3, C_4	Chip capacitors 1 nF
L_1	For optimized input matching - discrete inductor: approx. 3nH, or - printed microstripline inductor: Z approx. 100 Ω , l_p approx. 5 mm
L_2, L_3	- discrete inductor: approx. 40 nH, as e.g. 5 turns 0.25 mm copper wire on nylon rod with M3-thread, or - printed microstripline inductor
D	Z diode 5.6 V (type BZW 22 C5 V 6)

Total Power Dissipation $P_{tot} = f(T_S; T_A)$

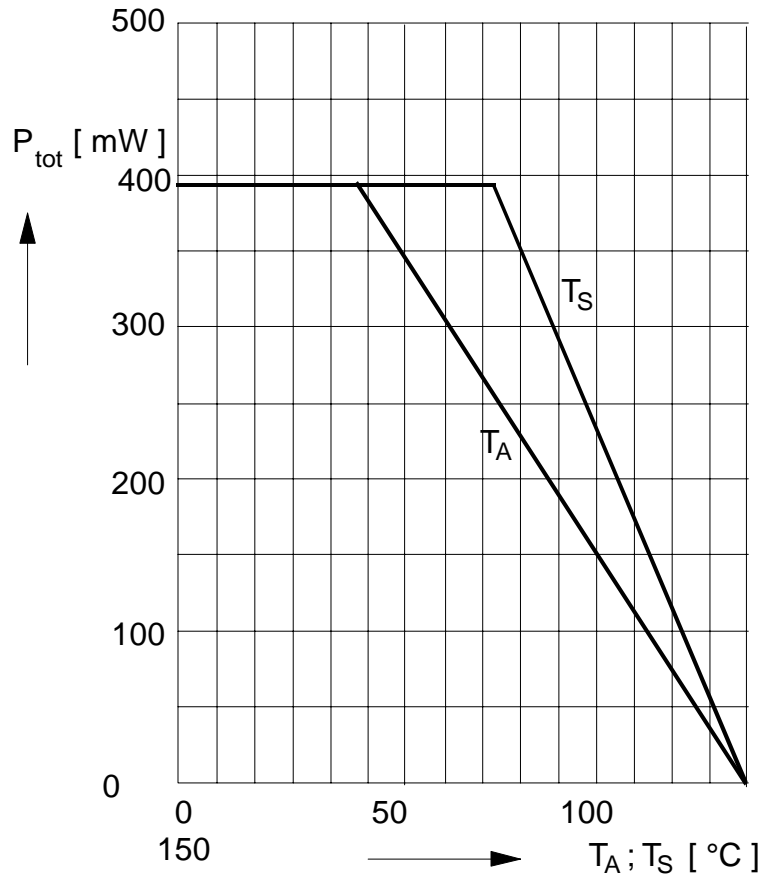

Typical Common Source S-Parameters

$$V_G = 0V \quad V_D = 4.5V \quad Z_0 = 50\ \Omega$$

f	S11		S21		S12		S22	
GHz	Mag	Ang	Mag	Ang	Mag	Ang	Mag	Ang
0.2	0.20	-47	3.32	165	0.14	2	0.09	-150
0.4	0.16	-49	3.24	158	0.14	-2	0.09	148
0.6	0.15	-60	3.17	149	0.14	-6	0.11	117
0.8	0.16	-72	3.09	141	0.14	-8	0.13	97
1.0	0.15	-87	3.02	132	0.13	-10	0.16	84
1.2	0.14	-105	2.95	124	0.13	-12	0.19	76
1.4	0.15	-124	2.88	116	0.13	-13	0.21	68
1.6	0.15	-139	2.82	107	0.12	-14	0.22	60
1.8	0.16	-151	2.75	100	0.12	-15	0.24	54
2.0	0.17	-166	2.69	93	0.11	-15	0.25	48
2.2	0.18	-176	2.62	86	0.11	-15	0.26	41
2.4	0.21	173	2.56	80	0.11	-14	0.27	37
2.6	0.21	163	2.48	73	0.11	-14	0.27	32
2.8	0.23	154	2.40	67	0.11	-14	0.27	28
3.0	0.24	146	2.32	61	0.11	-13	0.27	24
3.2	0.26	140	2.24	55	0.11	-12	0.27	20
3.4	0.29	136	2.15	51	0.11	-14	0.26	18
3.6	0.31	127	2.05	44	0.11	-12	0.25	17
3.8	0.32	123	1.94	39	0.11	-11	0.24	14
4.0	0.34	118	1.83	34	0.11	-11	0.23	10
4.2	0.36	115	1.80	29	0.11	-11	0.22	6



LittleDiode supplies new, hard to find or obsolete electronic components and semiconductors all over the world.

With over two million different components listed you are sure to find the part you need.

Feel free to visit us today at our online store:

LittleDiode.com

Looking forward to providing you with the best possible service.