

CLC5633

Triple, High Output, Programmable Gain Buffer

General Description

The CLC5633 is a triple, low-cost, high-speed (130MHz) buffer which features user-programmable gains of +2, +1, and -1V/V. The CLC5633 also has a new output stage that delivers high output drive current (130mA), but consumes minimal quiescent supply current (3.0mA/ch) from a single 5V supply. Its current feedback architecture, fabricated in an advanced complementary bipolar process, maintains consistent performance over a wide range of gains and signal levels, and has a linear-phase response up to one half of the -3dB frequency.

The CLC5633 offers 0.1dB gain flatness to 20MHz and differential gain and phase errors of 0.03% and 0.06°. These features are ideal for professional and consumer video applications.

The CLC5633 offers superior dynamic performance with a 130MHz small-signal bandwidth, 410V/ μ s slew rate and 5.0ns rise/fall times ($2V_{step}$). The combination of low quiescent power, high output current drive, and high-speed performance make the CLC5633 well suited for many battery-powered personal communication/computing systems.

The ability to drive low-impedance, highly capacitive loads, with minimum distortion makes the CLC5633 ideal for cable applications. The CLC5633 will drive a 100 Ω load with only -73/-92dBc second/third harmonic distortion ($A_v = +2$, $V_{out} = 2V_{pp}$, $f = 1$ MHz). With a 25 Ω load, and the same conditions, it produces only -75/-75dBc second/third harmonic distortion. It is also optimized for driving high currents into single-ended transformers and coils.

When driving the input of high-resolution A/D converters, the CLC5633 provides excellent -92/-96dBc second/third harmonic distortion ($A_v = +2$, $V_{out} = 2V_{pp}$, $f = 1$ MHz, $R_L = 1$ k Ω) and fast settling time.

Features

- 130mA output current
- 0.03%, 0.06° differential gain, phase
- 3.0mA/ch supply current
- 130MHz bandwidth ($A_v = +2$)
- -92/-96dBc HD2/HD3 (1MHz)
- 20ns settling to 0.05%
- 410V/ μ s slew rate
- Stable for capacitive loads up to 1000pf
- Single 5V to ± 5 V supplies

Applications

- Video line driver
- Coaxial cable driver
- Twisted pair driver
- Transformer/coil driver
- High capacitive load driver
- Portable/battery-powered applications
- A/D driver

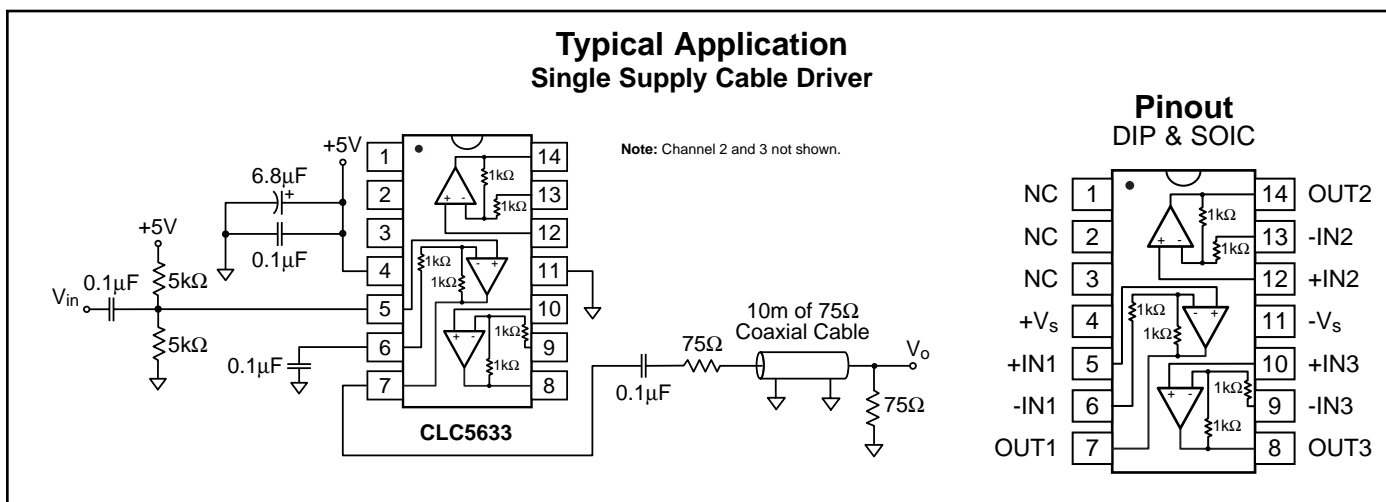
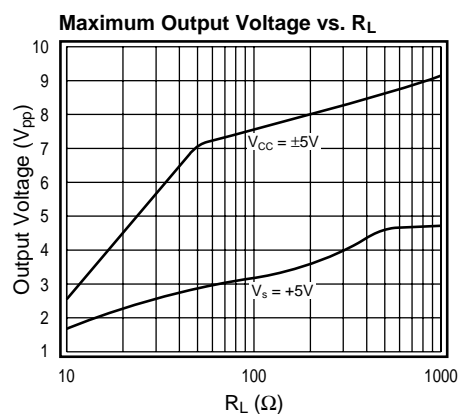

+5V Electrical Characteristics ($A_v = +2$, $R_L = 100\Omega$, $V_s = +5V^1$, $V_{cm} = V_{EE} + (V_s/2)$, R_L tied to V_{cm} , unless specified)

PARAMETERS	CONDITIONS	TYP	MIN/MAX RATINGS			UNITS	NOTES
Ambient Temperature	CLC5633IN/IM	+25°C	+25°C	0 to 70°C	-40 to 85°C		
FREQUENCY DOMAIN RESPONSE							
-3dB bandwidth	$V_o = 0.5V_{pp}$	100	80	70	70	MHz	
	$V_o = 2.0V_{pp}$	97	79	74	72	MHz	
-0.1dB bandwidth	$V_o = 0.5V_{pp}$	20	17	17	13	MHz	
gain peaking	<200MHz, $V_o = 0.5V_{pp}$	0	0.5	1.0	1.0	dB	
gain rolloff	<30MHz, $V_o = 0.5V_{pp}$	0.2	0.5	0.6	0.6	dB	
linear phase deviation	<30MHz, $V_o = 0.5V_{pp}$	0.15	0.3	0.4	0.4	deg	
differential gain	NTSC, $R_L = 150\Omega$ to -1V	0.04	–	–	–	%	
differential phase	NTSC, $R_L = 150\Omega$ to -1V	0.1	–	–	–	deg	
TIME DOMAIN RESPONSE							
rise and fall time	2V step	4.8	6.4	6.8	7.3	ns	
settling time to 0.05%	1V step	20	24	40	60	ns	
overshoot	2V step	5	7	11	14	%	
slew rate	2V step	290	170	150	140	V/ μ s	
DISTORTION AND NOISE RESPONSE							
2 nd harmonic distortion	2V _{pp} , 1MHz	-72	–	–	–	dBc	
	2V _{pp} , 1MHz; $R_L = 1k\Omega$	-84	–	–	–	dBc	
	2V _{pp} , 5MHz	-71	-54	-52	-52	dBc	
3 rd harmonic distortion	2V _{pp} , 1MHz	-87	–	–	–	dBc	
	2V _{pp} , 1MHz; $R_L = 1k\Omega$	-95	–	–	–	dBc	
	2V _{pp} , 5MHz	-78	-61	-54	-54	dBc	
equivalent input noise							
voltage (e_{ni})	>1MHz	4.9	5.9	6.4	6.4	nV/ \sqrt Hz	
non-inverting current (i_{bn})	>1MHz	6.6	8.5	9.3	9.3	pA/ \sqrt Hz	
inverting current (i_{bi})	>1MHz	11.1	14.7	15.8	15.8	pA/ \sqrt Hz	
crosstalk (input referred)	10MHz, 1V _{pp}	-54	–	–	–	dB	
crosstalk, all hostile (input referred)	10MHz, 1V _{pp}	-52	–	–	–	dB	
STATIC DC PERFORMANCE							
input offset voltage		13	30	35	35	mV	A
average drift		80	–	–	–	μ V/°C	
input bias current (non-inverting)		5	18	24	24	μ A	A
average drift		30	–	–	–	nA/°C	
gain accuracy		\pm 0.3	\pm 1.5	\pm 2.0	\pm 2.0	%	A
internal resistors (R_f , R_g)		1000	\pm 20%	\pm 26%	\pm 30%	Ω	
power supply rejection ratio	DC	48	45	43	43	dB	
common-mode rejection ratio	DC	44	41	39	39	dB	
supply current (per amplifier)	$R_L = \infty$	3.0	3.4	3.6	3.6	mA	A
MISCELLANEOUS PERFORMANCE							
input resistance (non-inverting)		1.0	0.62	0.56	0.56	M Ω	
input capacitance (non-inverting)		2.2	3.3	3.3	3.3	pF	
input voltage range, High		4.2	4.1	4.0	4.0	V	
input voltage range, Low		0.8	0.9	1.0	1.0	V	
output voltage range, High	$R_L = 100\Omega$	4.0	3.9	3.8	3.8	V	
output voltage range, Low	$R_L = 100\Omega$	1.0	1.1	1.2	1.2	V	
output voltage range, High	$R_L = \infty$	4.1	4.0	4.0	3.9	V	
output voltage range, Low	$R_L = \infty$	0.9	1.0	1.0	1.1	V	
output current		100	80	65	40	mA	B
output resistance, closed loop	DC	400	600	600	600	m Ω	

Min/max ratings are based on product characterization and simulation. Individual parameters are tested as noted. Outgoing quality levels are determined from tested parameters.

Notes

- A) J-level: spec is 100% tested at +25°C.
 B) The short circuit current can exceed the maximum safe output current.
 1) $V_s = V_{CC} - V_{EE}$

Absolute Maximum Ratings

supply voltage ($V_{CC} - V_{EE}$)	+14V
output current (see note C)	140mA
common-mode input voltage	V_{EE} to V_{CC}
maximum junction temperature	+150°C
storage temperature range	-65°C to +150°C
lead temperature (soldering 10 sec)	+300°C
ESD rating (human body model)	2000V

Reliability Information

Transistor Count	147
MTBF (based on limited test data)	301Mhr

±5V Electrical Characteristics (A_v = +2, R_L = 100Ω, V_{CC} = ±5V, unless specified)

PARAMETERS	CONDITIONS	TYP	GUARANTEED MIN/MAX				UNITS	NOTES
			+25°C	+25°C	0 to 70°C	-40 to 85°C		
Ambient Temperature	CLC5633IN/IM	+25°C	+25°C	0 to 70°C	-40 to 85°C			
FREQUENCY DOMAIN RESPONSE								
-3dB bandwidth	V _o = 1.0V _{pp}	130	100	90	90	MHz		
	V _o = 4.0V _{pp}	80	60	55	55	MHz		
-0.1dB bandwidth	V _o = 1.0V _{pp}	20	17	12	12	MHz		
gain peaking	<200MHz, V _o = 1.0V _{pp}	0	0.5	1.0	1.0	dB		
gain rolloff	<30MHz, V _o = 1.0V _{pp}	0.1	0.3	0.5	0.5	dB		
linear phase deviation	<30MHz, V _o = 1.0V _{pp}	0.2	0.4	0.6	0.6	deg		
differential gain	NTSC, R _L =150Ω	0.03	0.08	–	–	%		
differential phase	NTSC, R _L =150Ω	0.06	0.1	–	–	deg		
TIME DOMAIN RESPONSE								
rise and fall time	2V step	5.0	6.5	7.0	7.7	ns		
settling time to 0.05%	2V step	20	30	44	67	ns		
overshoot	2V step	14	17	18	19	%		
slew rate	2V step	410	310	240	225	V/μs		
DISTORTION AND NOISE RESPONSE								
2 nd harmonic distortion	2V _{pp} , 1MHz	-73	–	–	–	dBc		
	2V _{pp} , 1MHz; R _L = 1kΩ	-92	–	–	–	dBc		
	2V _{pp} , 5MHz	-69	-58	-56	-56	dBc		
3 rd harmonic distortion	2V _{pp} , 1MHz	-92	–	–	–	dBc		
	2V _{pp} , 1MHz; R _L = 1kΩ	-96	–	–	–	dBc		
	2V _{pp} , 5MHz	-72	-66	-65	-65	dBc		
equivalent input noise								
voltage (e _{ni})	>1MHz	4.9	5.9	6.4	6.4	nV/√Hz		
non-inverting current (i _{bn})	>1MHz	6.6	8.5	9.3	9.0	pA/√Hz		
inverting current (i _{bi})	>1MHz	11.1	14.7	15.8	15.8	pA/√Hz		
crosstalk (input referred)	10MHz, 1V _{pp}	-54	–	–	–	dB		
crosstalk, all hostile (input referred)	10MHz, 1V _{pp}	-52	–	–	–	dB		
STATIC DC PERFORMANCE								
output offset voltage		7	30	35	35	mV		
average drift		80	–	–	–	μV/°C		
input bias current (non-inverting)		5	18	25	25	μA		
average drift		40	–	–	–	nA/°C		
gain accuracy		±0.3	±1.5	±2.0	±2.0	%		
internal resistors (R _f , R _g)		1000	±20%	±26%	±30%	Ω		
power supply rejection ratio	DC	48	45	43	43	dB		
common-mode rejection ratio	DC	44	41	39	39	dB		
supply current (per amplifier)	R _L = ∞	3.2	3.8	4.0	4.0	mA		
MISCELLANEOUS PERFORMANCE								
input resistance (non-inverting)		1.1	0.63	0.57	0.57	MΩ		
input capacitance (non-inverting)		1.9	2.85	2.85	2.85	pF		
common-mode input range		±4.2	±4.1	±4.1	±4.0	V		
output voltage range	R _L = 100Ω	±3.8	±3.6	±3.6	±3.5	V		
output voltage range	R _L = ∞	±4.0	±3.8	±3.8	±3.7	V		
output current		130	100	80	50	mA	B	
output resistance, closed loop	DC	400	600	600	600	mΩ		

Notes

B) The short circuit current can exceed the maximum safe output current.

Package Thermal Resistance

Package	θ _{JC}	θ _{JA}
Plastic (IN)	60°C/W	110°C/W
Surface Mount (IM)	55°C/W	125°C/W

Ordering Information

Model	Temperature Range	Description
CLC5633IN	-40°C to +85°C	8-pin PDIP
CLC5633IM	-40°C to +85°C	8-pin SOIC
CLC5633IMX	-40°C to +85°C	8-pin SOIC tape and reel

+5V Typical Performance ($A_v = +2$, $R_L = 100\Omega$, $V_s = +5V^1$, $V_{cm} = V_{EE} + (V_s/2)$, R_L tied to V_{cm} , unless specified)

Frequency Response

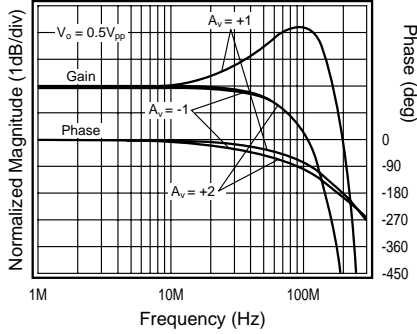

Frequency Response vs. R_L

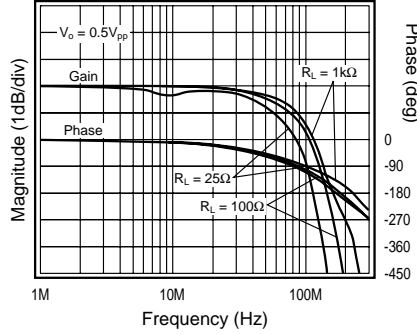

Gain Flatness & Linear Phase

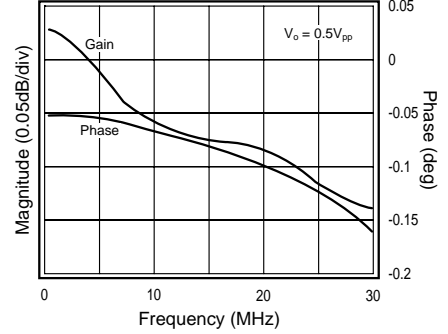

Frequency Response vs. V_o ($A_v = 2$)

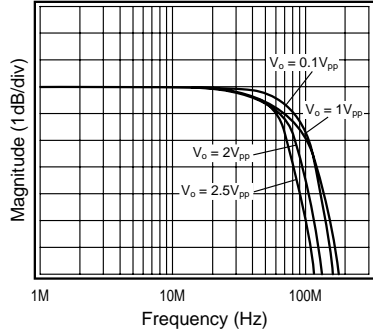

Frequency Response vs. V_o ($A_v = 1$)

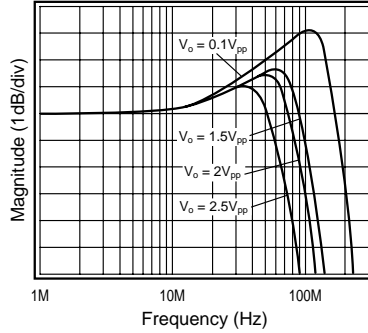

Frequency Response vs. V_o ($A_v = -1$)

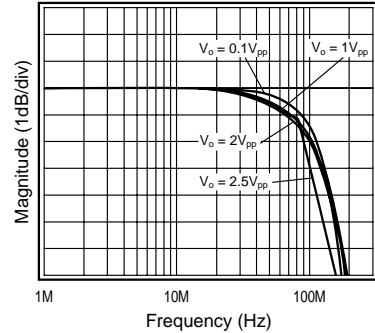

PSRR & CMRR

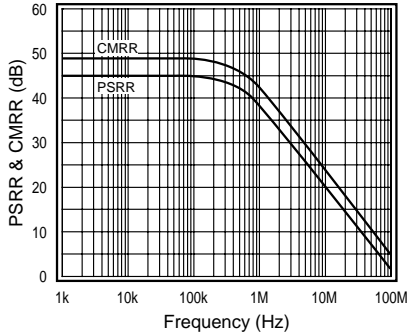

Equivalent Input Noise

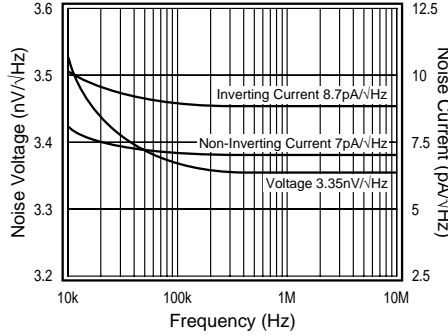

2nd & 3rd Harmonic Distortion

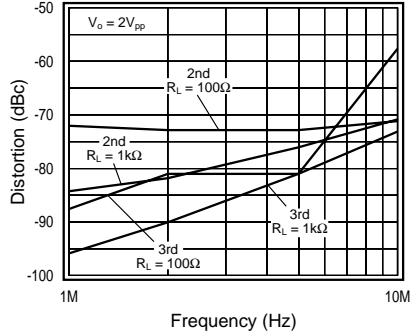

2nd & 3rd Harmonic Distortion, $R_L =$

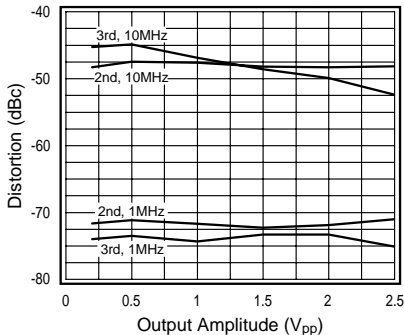

2nd & 3rd Harmonic Distortion, $R_L = 100\Omega$

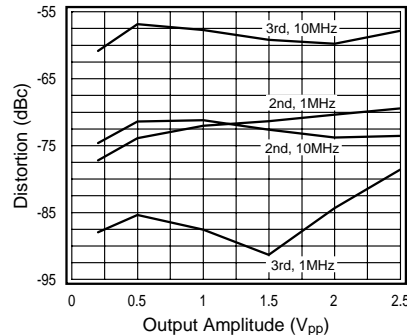

2nd & 3rd Harmonic Distortion, $R_L = 1k\Omega$

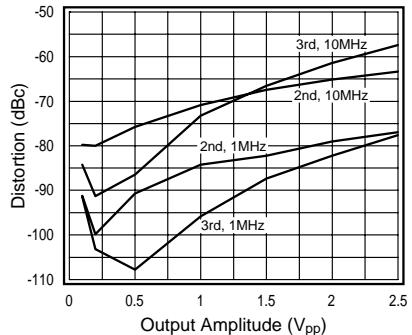

Large & Small Signal Pulse Response

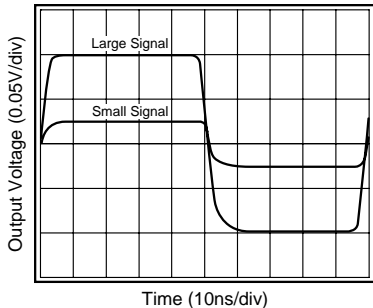

Output Impedance vs. Frequency

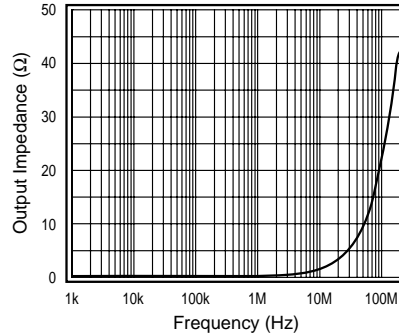

I_{BN} & V_{IO} vs. Temperature

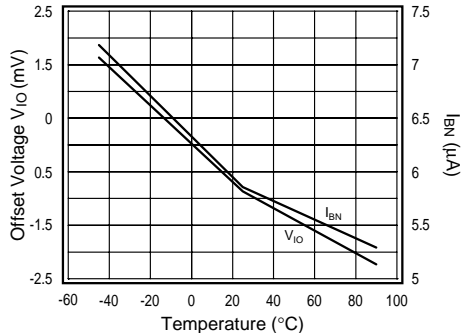

±5V Typical Performance ($A_v = +2$, $R_L = 100\Omega$, $V_{CC} = \pm 5V$, unless specified)

Frequency Response

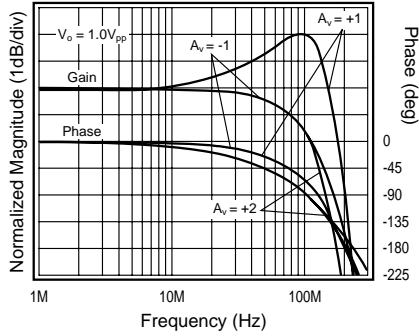

Frequency Response vs. R_L

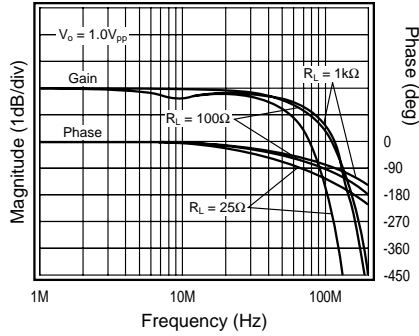

Gain Flatness & Linear Phase

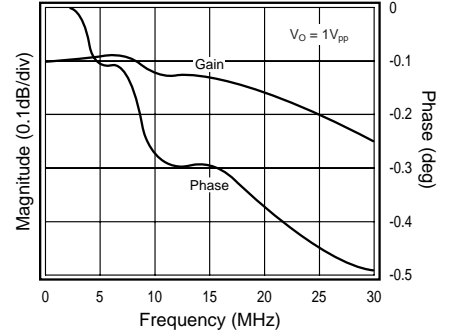

Frequency Response vs. V_o ($A_v = 2$)

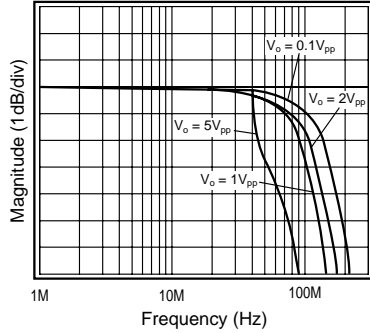

Frequency Response vs. V_o ($A_v = 1$)

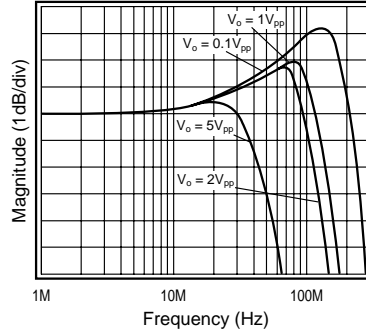

Frequency Response vs. V_o ($A_v = -1$)

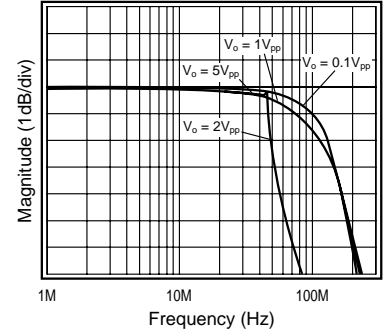

Large & Small Signal Pulse Response

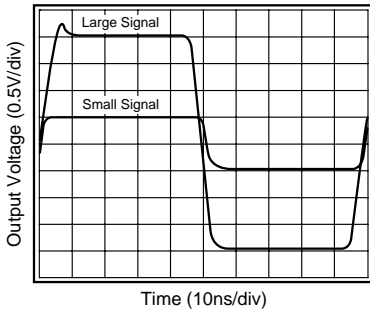

Differential Gain & Phase

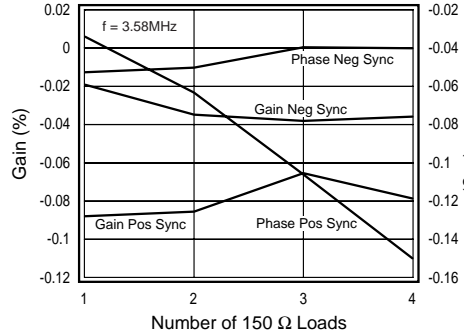

2nd & 3rd Harmonic Distortion

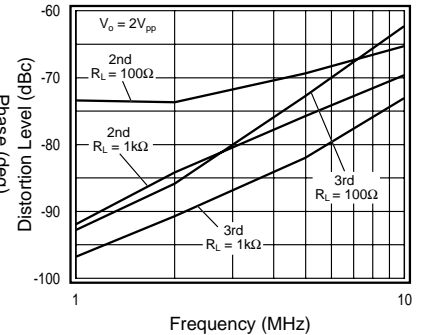

2nd & 3rd Harmonic Distortion, $R_L = 25\Omega$

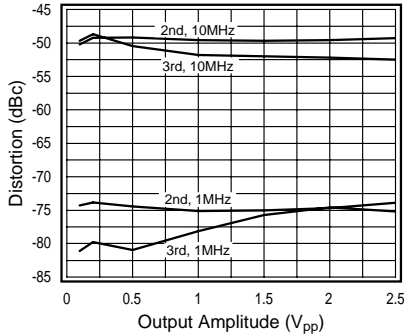

2nd & 3rd Harmonic Distortion, $R_L = 100\Omega$

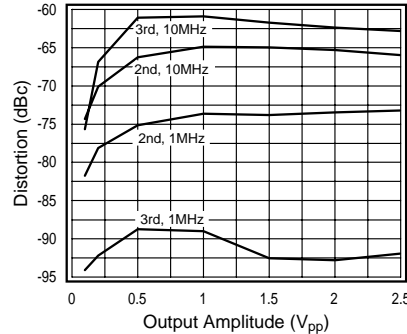

2nd & 3rd Harmonic Distortion, $R_L = 1k\Omega$

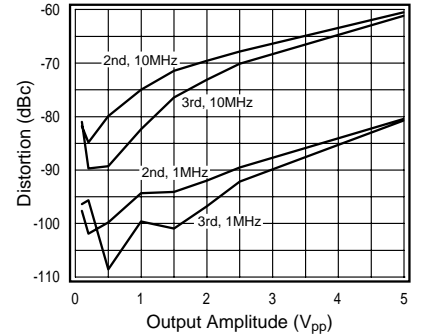

Short Term Settling Time

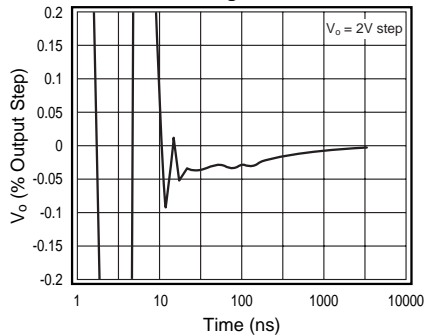

Long Term Settling Time

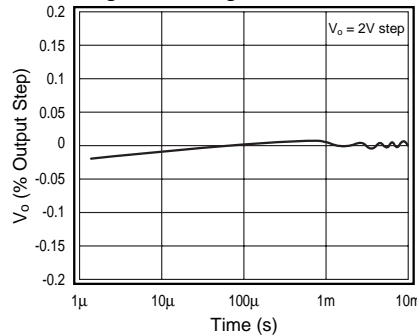

I_{BN} & V_{OS} vs. Temperature

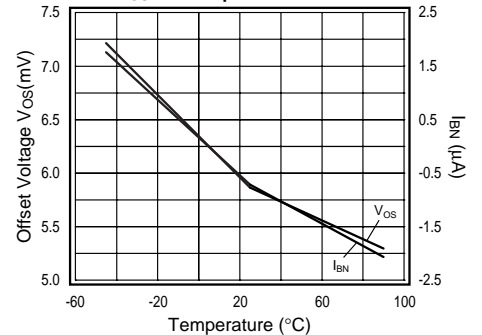

±5V Typical Channel Matching Performance ($A_v = +2$, $R_L = 100\Omega$, $V_{CC} = \pm 5V$, unless specified)

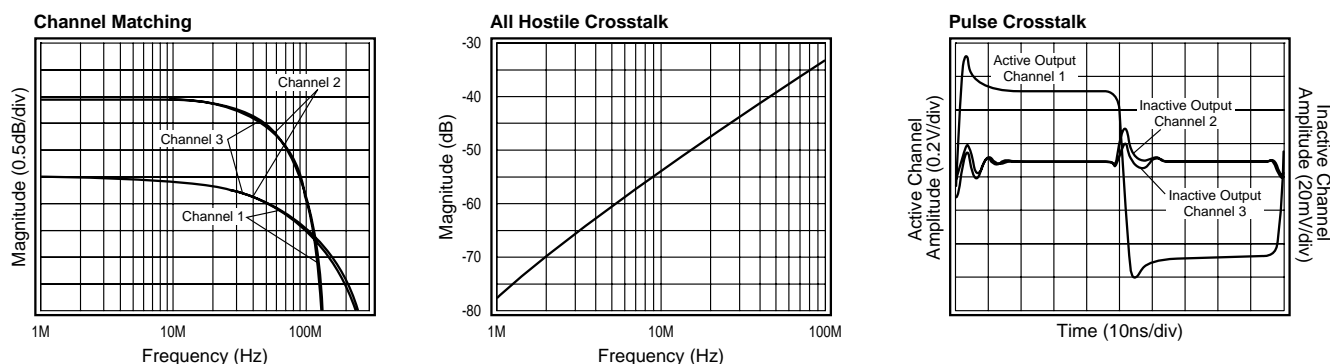

CLC5633 Operation

The CLC5633 is a current feedback buffer built in an advanced complementary bipolar process. The CLC5633 operates from a single 5V supply or dual ±5V supplies. Operating from a single 5V supply, the CLC5633 has the following features:

- Gains of +1, -1, and 2V/V are achievable without external resistors
- Provides 100mA of output current while consuming only 15mW of power
- Offers low -84/-95dBc 2nd and 3rd harmonic distortion
- Provides BW > 90MHz and 1MHz distortion < -70dBc at $V_o = 2V_{pp}$

The CLC5633 performance is further enhanced in ±5V supply applications as indicated in the **±5V Electrical Characteristics** table and **±5V Typical Performance** plots.

If gains other than +1, -1, or +2V/V are required, then the CLC5602 can be used. The CLC5602 is a current feedback amplifier with near identical performance and allows for external feedback and gain setting resistors.

Current Feedback Amplifiers

Some of the key features of current feedback technology are:

- Independence of AC bandwidth and voltage gain
- Inherently stable at unity gain
- Adjustable frequency response with feedback resistor
- High slew rate
- Fast settling

Current feedback operation can be described using a simple equation. The voltage gain for a non-inverting or inverting current feedback amplifier is approximated by Equation 1.

$$\frac{V_o}{V_{in}} = \frac{A_v}{1 + \frac{R_f}{Z(j\omega)}} \quad \text{Equation 1}$$

where:

- A_v is the closed loop DC voltage gain
- R_f is the feedback resistor
- $Z(j\omega)$ is the CLC5633's open loop transimpedance gain
- $\frac{Z(j\omega)}{R_f}$ is the loop gain

The denominator of Equation 1 is approximately equal to 1 at low frequencies. Near the -3dB corner frequency, the interaction between R_f and $Z(j\omega)$ dominates the circuit performance. The value of the feedback resistor has a large affect on the circuits performance. Increasing R_f has the following affects:

- Decreases loop gain
- Decreases bandwidth
- Reduces gain peaking
- Lowers pulse response overshoot
- Affects frequency response phase linearity

CLC5633 Design Information

Closed Loop Gain Selection

The CLC5633 is a current feedback op amp with $R_f = R_g = 1k\Omega$ on chip (in the package). Select from three closed loop gains without using any external gain or feedback resistors. Implement gains of +2, +1, and -1V/V by connecting pins 5 and 6 (or 9 and 10, or 12 and 13) as described in the chart below.

Gain A_v	Input Connections	
	Non-Inverting (pins 5,10, & 12)	Inverting (pins 6,9, & 13)
-1V/V	ground	input signal
+1V/V	input signal	NC (open)
+2V/V	input signal	ground

The gain accuracy of the CLC5633 is excellent and stable over temperature change. The internal gain setting resistors, R_f and R_g are diffused silicon resistors with a process variation of $\pm 20\%$ and a temperature coefficient of $\sim 2000\text{ppm}/^\circ\text{C}$. Although their absolute values change with processing and temperature, their ratio (R_f/R_g) remains constant. If an external resistor is used in series with R_g , gain accuracy over temperature will suffer.

Single Supply Operation ($V_{CC} = +5V, V_{EE} = \text{GND}$)

The specifications given in the **+5V Electrical Characteristics** table for single supply operation are measured with a common mode voltage (V_{cm}) of 2.5V. V_{cm} is the voltage around which the inputs are applied and the output voltages are specified.

Operating from a single +5V supply, the Common Mode Input Range (CMIR) of the CLC5633 is typically +0.8V to +4.2V. The typical output range with $R_L=100\Omega$ is +1.0V to +4.0V.

For single supply DC coupled operation, keep input signal levels above 0.8V DC. For input signals that drop below 0.8V DC, AC coupling and level shifting the signal are recommended. The non-inverting and inverting configurations for both input conditions are illustrated in the following 2 sections.

DC Coupled Single Supply Operation

Figures 1, 2, and 3 on the following page, show the recommended configurations for input signals that remain above 0.8V DC.

Note: R_b provides DC bias for the non-inverting input. R_b, R_t , and R_i are tied to V_{cm} for minimum power consumption and maximum output swing. Channel 2 and 3 not shown.

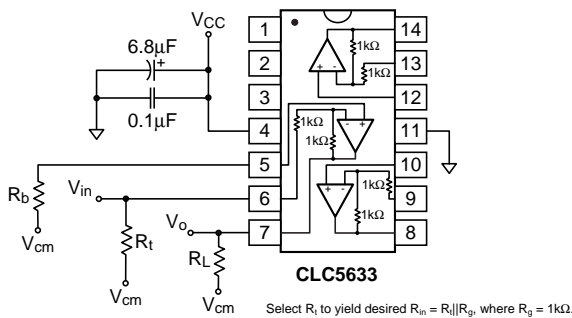

Figure 1: DC Coupled, $A_v = -1/V$ Configuration

Note: R_f and R_L are tied to V_{cm} for minimum power consumption and maximum output swing. Channel 2 and 3 not shown.

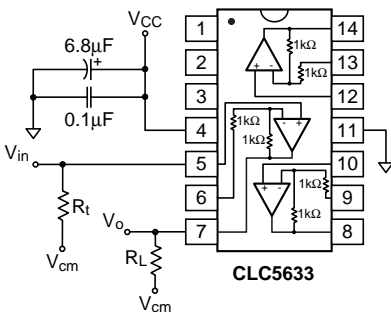

Figure 2: DC Coupled, $A_v = +1/V$ Configuration

Note: R_f and R_L and R_g are tied to V_{cm} for minimum power consumption and maximum output swing. Channel 2 and 3 not shown.

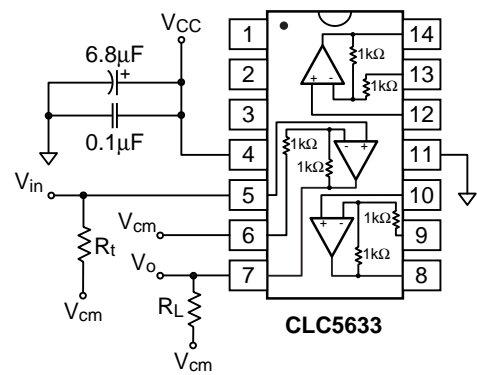

Figure 3: DC Coupled, $A_v = +2V/V$ Configuration

AC Coupled Single Supply Operation

Figures 4, 5, and 6 show possible non-inverting and inverting configurations for input signals that go below 0.8V DC.

Note: Channel 2 and 3 not shown.

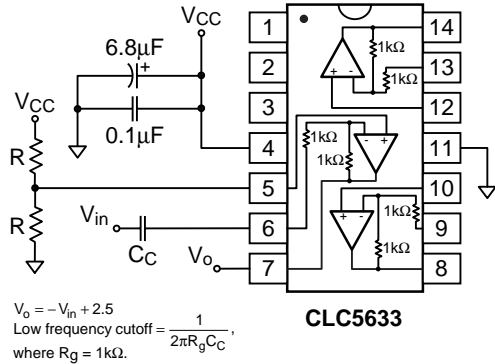

Figure 4: AC Coupled, $A_v = -1/V$ Configuration

The input is AC coupled to prevent the need for level shifting the input signal at the source. The resistive voltage divider biases the non-inverting input to $V_{CC} \div 2 = 2.5V$ (For $V_{CC} = +5V$).

Note: Channel 2 and 3 not shown.

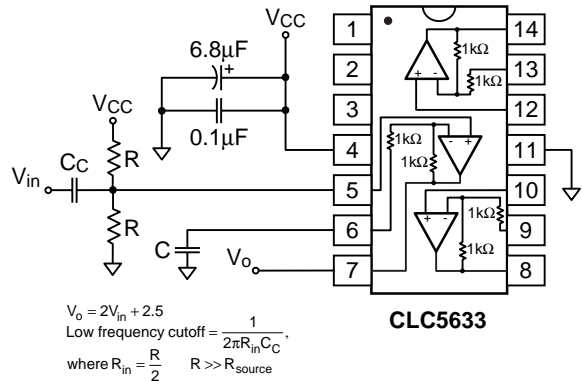
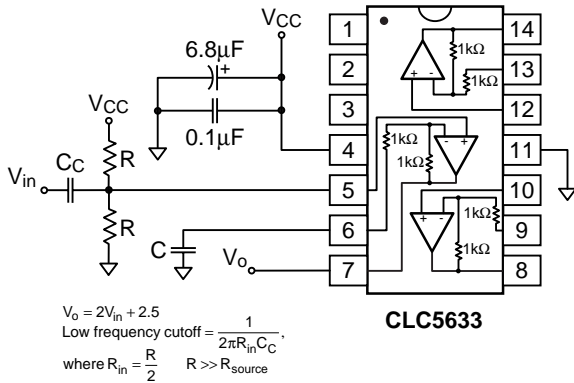

Figure 5: AC Coupled, $A_v = +1/V$ Configuration

Note: Channel 2 and 3 not shown.



$$V_o = 2V_{in} + 2.5$$

$$\text{Low frequency cutoff} = \frac{1}{2\pi R_{in} C_C}$$

where $R_{in} = \frac{R}{2}$ $R \gg R_{source}$

Figure 6: AC Coupled, $A_v = +2V/V$ Configuration

Note: Channel 2 and 3 not shown.

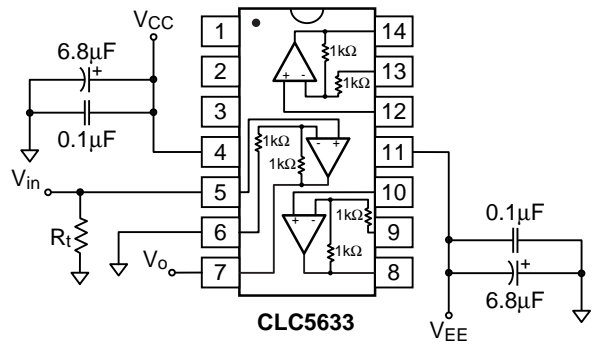

Figure 9: Dual Supply, $A_v = +2V/V$ Configuration

Dual Supply Operation

The CLC5633 operates on dual supplies as well as single supplies. The non-inverting and inverting configurations are shown in Figures 7, 8 and 9.

Note: R_b provides DC bias for the non-inverting input. Select R_t to yield desired $R_{in} = R_b || 1k\Omega$. Channel 2 and 3 not shown.

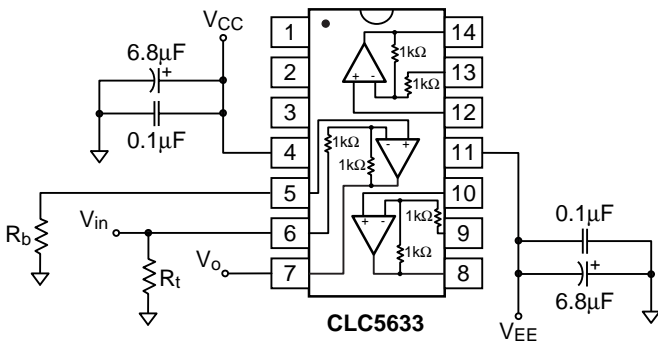

Figure 7: Dual Supply, $A_v = -1V/V$ Configuration

Note: Channel 2 and 3 not shown.

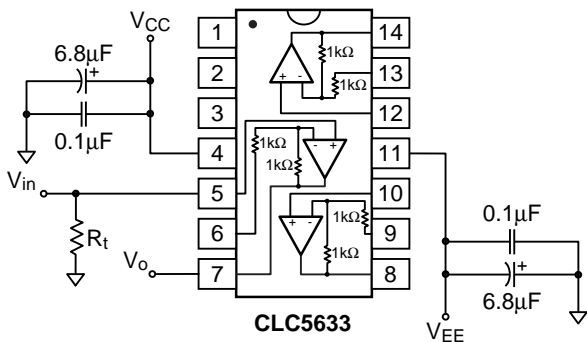

Figure 8: Dual Supply, $A_v = +1V/V$ Configuration

Load Termination

The CLC5633 can source and sink near equal amounts of current. For optimum performance, the load should be tied to V_{cm} .

Driving Cables and Capacitive Loads

When driving cables, double termination is used to prevent reflections. For capacitive load applications, a small series resistor at the output of the CLC5633 will improve stability and settling performance. The **Frequency Response vs. C_L** plot, shown below in Figure 10, gives the recommended series resistance value for optimum flatness at various capacitive loads.

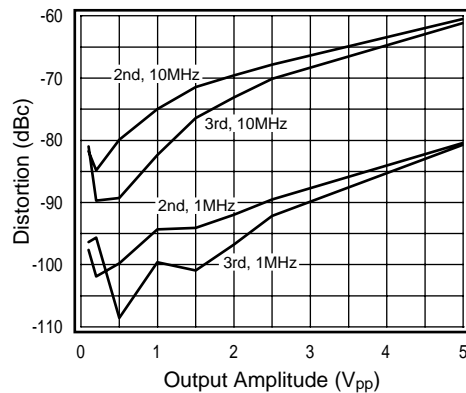

Figure 10: Frequency Response vs. C_L

Transmission Line Matching

One method for matching the characteristic impedance (Z_o) of a transmission line or cable is to place the appropriate resistor at the input or output of the amplifier. Figure 11 shows typical inverting and non-inverting circuit configurations for matching transmission lines.

Non-inverting gain applications:

- Connect pin 2 as indicated in the table in the **Closed Loop Gain Selection** section.
- Make R_1 , R_2 , R_6 , and R_7 equal to Z_0 .
- Use R_3 to isolate the amplifier from reactive loading caused by the transmission line, or by parasitics.

Inverting gain applications:

- Connect R_3 directly to ground.
- Make the resistors R_4 , R_6 , and R_7 equal to Z_0 .
- Make $R_5 \parallel R_g = Z_0$.

The input and output matching resistors attenuate the signal by a factor of 2, therefore additional gain is needed. Use C_6 to match the output transmission line over a greater frequency range. C_6 compensates for the increase of the amplifier's output impedance with frequency

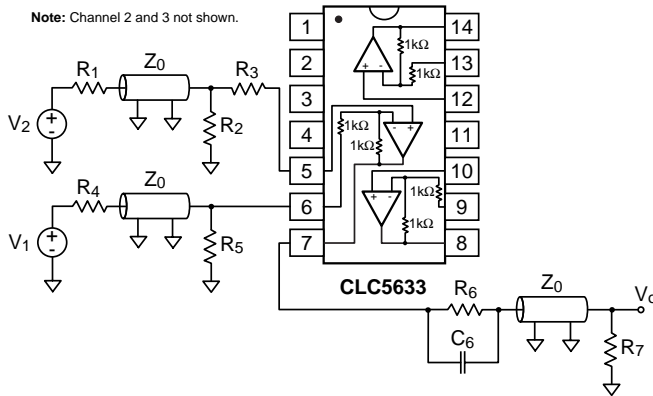

Figure 11: Transmission Line Matching

Power Dissipation

Follow these steps to determine the power consumption of the CLC5633:

1. Calculate the quiescent (no-load) power:

$$P_{amp} = I_{CC} (V_{CC} - V_{EE})$$
2. Calculate the RMS power at the output stage:

$$P_o = (V_{CC} - V_{load}) (I_{load})$$
, where V_{load} and I_{load} are the RMS voltage and current across the external load.
3. Calculate the total RMS power:

$$P_t = P_{amp} + P_o$$

The maximum power that the DIP and SOIC packages can dissipate at a given temperature is illustrated in Figure 12. The power derating curve for any CLC5633 package can be derived by utilizing the following equation:

$$\frac{(175^\circ - T_{amb})}{\theta_{JA}}$$

where

- T_{amb} = Ambient temperature ($^\circ\text{C}$)
- θ_{JA} = Thermal resistance, from junction to ambient, for a given package ($^\circ\text{C}/\text{W}$)

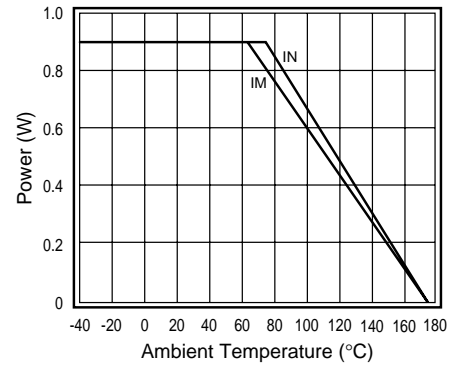

Figure 12: Power Derating Curve

Layout Considerations

A proper printed circuit layout is essential for achieving high frequency performance. National provides evaluation boards for the CLC5633 (CLC730075-DIP, CLC730074-SOIC) and suggests their use as a guide for high frequency layout and as an aid for device testing and characterization.

General layout and supply bypassing play major roles in high frequency performance. Follow the steps below as a basis for high frequency layout:

- Include 6.8 μF tantalum and 0.1 μF ceramic capacitors on both supplies.
- Place the 6.8 μF capacitors within 0.75 inches of the power pins.
- Place the 0.1 μF capacitors less than 0.1 inches from the power pins.
- Remove the ground plane under and around the part, especially near the input and output pins to reduce parasitic capacitance.
- Minimize all trace lengths to reduce series inductances.
- Use flush-mount printed circuit board pins for prototyping, never use high profile DIP sockets.

Evaluation Board Information

A data sheet is available for the CLC730075/ CLC730074 evaluation boards. The evaluation board data sheets provide:

- Evaluation board schematics
- Evaluation board layouts
- General information about the boards

The evaluation boards are designed to accommodate dual supplies. The boards can be modified to provide single supply operation. For best performance; 1) do not connect the unused supply, 2) ground the unused supply pin.

Special Evaluation Board

Considerations for the CLC5633

To optimize off-isolation of the CLC5633, cut the R_f trace on both the CLC730074 and the CLC730075 evaluation boards. This cut minimizes capacitive feedthrough between the input and the output.

SPICE Models

SPICE models provide a means to evaluate amplifier designs. Free SPICE models are available for National's monolithic amplifiers that:

- Support Berkeley SPICE 2G and its many derivatives
- Reproduce typical DC, AC, Transient, and Noise performance
- Support room temperature simulations

The *readme* file that accompanies the diskette lists released models, and provides a list of modeled parameters. The application note OA-18, Simulation SPICE Models for National's Op Amps, contains schematics and a reproduction of the readme file.

Application Circuits

Single Supply Cable Driver

Figure 13 below shows the CLC5633 driving 10m of 75 Ω coaxial cable. The CLC5633 is set for a gain of +2V/V

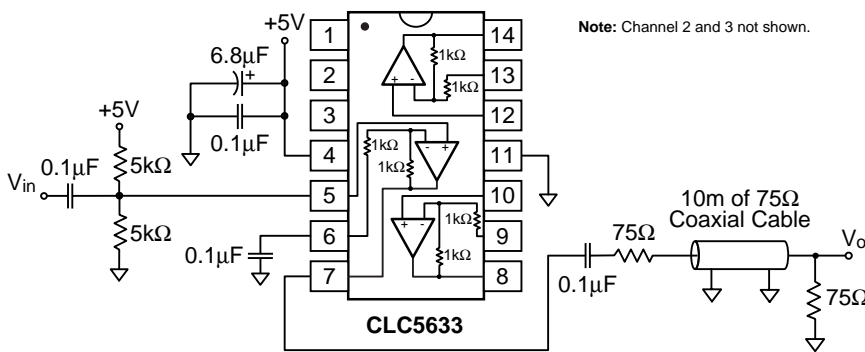

Figure 13: Single Supply Cable Driver

to compensate for the divide-by-two voltage drop at V_o . The response after 10m of cable is illustrated in Figure 14.

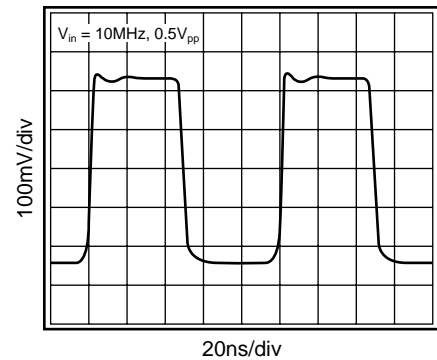

Figure 14: Response After 10m of Cable

This page intentionally left blank.

Customer Design Applications Support

National Semiconductor is committed to design excellence. For sales, literature and technical support, call the National Semiconductor Customer Response Group at **1-800-272-9959** or fax **1-800-737-7018**.

Life Support Policy

National's products are not authorized for use as critical components in life support devices or systems without the express written approval of the president of National Semiconductor Corporation. As used herein:

1. Life support devices or systems are devices or systems which, a) are intended for surgical implant into the body, or b) support or sustain life, and whose failure to perform, when properly used in accordance with instructions for use provided in the labeling, can be reasonably expected to result in a significant injury to the user.
2. A critical component is any component of a life support device or system whose failure to perform can be reasonably expected to cause the failure of the life support device or system, or to affect its safety or effectiveness.



National Semiconductor Corporation

1111 West Bardin Road
Arlington, TX 76017
Tel: 1(800) 272-9959
Fax: 1(800) 737-7018

National Semiconductor Europe

Fax: (+49) 0-180-530 85 86
E-mail: europe.support.nsc.com
Deutsch Tel: (+49) 0-180-530 85 85
English Tel: (+49) 0-180-532 78 32
Francais Tel: (+49) 0-180-532 93 58
Italiano Tel: (+49) 0-180-534 16 80

National Semiconductor Hong Kong Ltd.

2501 Miramar Tower
1-23 Kimberley Road
Tsimshatsui, Kowloon
Hong Kong
Tel: (852) 2737-1600
Fax: (852) 2736-9960

National Semiconductor Japan Ltd.

Tel: 81-043-299-2309
Fax: 81-043-299-2408

National does not assume any responsibility for use of any circuitry described, no circuit patent licenses are implied and National reserves the right at any time without notice to change said circuitry and specifications.

This datasheet has been downloaded from:

www.DatasheetCatalog.com

Datasheets for electronic components.

National Semiconductor was acquired by Texas Instruments.

http://www.ti.com/corp/docs/investor_relations/pr_09_23_2011_national_semiconductor.html

This file is the datasheet for the following electronic components:

CLC5633IN - <http://www.ti.com/product/clc5633in?HQS=TI-null-null-dscatalog-df-pf-null-wwe>

CLC5633IMX - <http://www.ti.com/product/clc5633imx?HQS=TI-null-null-dscatalog-df-pf-null-wwe>

CLC5633IM - <http://www.ti.com/product/clc5633im?HQS=TI-null-null-dscatalog-df-pf-null-wwe>



LittleDiode supplies new, hard to find or obsolete electronic components and semiconductors all over the world.

With over two million different components listed you are sure to find the part you need.

Feel free to visit us today at our online store:

LittleDiode.com

Looking forward to providing you with the best possible service.