

# 50mA F to V Converter

## Description

The CS-2907/2917 Series is designed for use in frequency-to-voltage conversion systems and is especially suitable for tachometer and motor-speed-control applications. The 2907 consists of a regenerative input comparator, a frequency doubling charge pump and a general purpose, differential op-amp output. The 2917 has the additional built-in feature of an internal shunt voltage regulator. The input signal, which can be single-ended, or differential, is applied to the regenerative comparator input; 30mV hysteresis provides noise rejection.

The frequency-doubling charge pump is triggered by the comparator output, converting the input-frequency information into a d.c. output voltage at  $F/V_{OUT}$ . The output op-amp is unity-gain compensated and can serve as an output-voltage follower or as an active filter for additional ripple reduction. 50mA current capability allows the output stage to drive a variety of loads either from emitter, or collector.

The output swings to ground for zero frequency input.

## Absolute Maximum Ratings

Supply Voltage.....	28V
Supply Current.....	25mA
Op. Amp./Comp. Differential Input Voltage .....	28V
Op. Amp./Comparator Input Voltage.....	28V
Op. Amp. Collector-Emitter Voltage.....	28V
Digital Interface Collector-Emitter Voltage.....	28V
Operating Temperature Range.....	-40°C to +85°C
Storage Temperature Range .....	-65°C to +150°C
Lead Temperature Soldering	
Wave Solder(through hole styles only).....	10 sec. max, 260°C peak

## Block Diagram

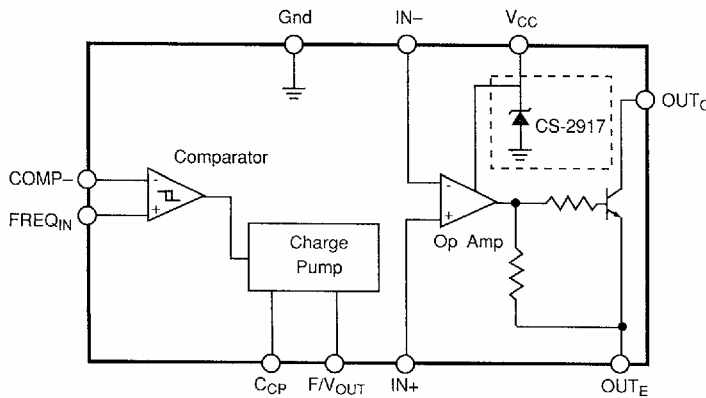

## Features

- ±0.3% Linearity, Typical
- Buffered High-Level Frequency Output
- Single-ended or Differential Inputs
- Voltage Follower or Active Filter Output Capability
- Output Swings to Ground for Zero Frequency Input

## Package Options

### 8L PDIP

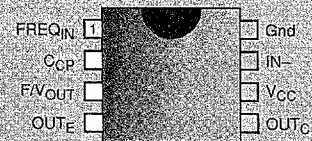

### 14L PDIP

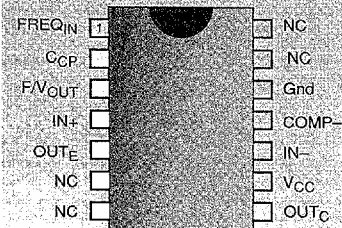

PARAMETER	TEST CONDITIONS	MIN	TYP	MAX	UNIT
<b>■ Comparator</b>					
Input Threshold Voltage	$V_{FREQIN} = \pm 125\text{mV}$ note 2	$\pm 10$	$\pm 15$	$\pm 40$	mV
Hysteresis	$V_{FREQIN} = \pm 125\text{mV}$ note 2		30		mV
Input Offset Voltage					
-D14 Versions	note 2		3.5	10	mV
-D8 Versions	note 2		5	15	mV
Input Bias Current	$V_{FREQIN} = \pm 50\text{mV}$		0.1	1.0	$\mu\text{A}$
Common Mode Voltage				$V_{CC} - 1.5$	V
<b>■ Charge Pump</b>					
Output Voltage - high, $V_{OH}$					
CS-2907 Series	$V_{FREQIN} = +125\text{mV}_{DC}$ note 3		8.3		V
CS-2917 Series	$V_{FREQIN} = +125\text{mV}_{DC}$ note 3		5		V
Output Voltage - low, $V_{OL}$					
CS-2907 Series	$V_{FREQIN} = -125\text{mV}_{DC}$ note 3		2.3		V
CS-2917 Series	$V_{FREQIN} = -125\text{mV}_{DC}$ note 3		1.2		V
Output Current I <sub>pin 2</sub> , I <sub>pin 3</sub>					
CS-2907 Series	$V_{CCP} = V_F/V_{OUT} = 6V_{DC}$ note 4	140	180	240	$\mu\text{A}$
CS-2917 Series	$V_{CCP} = V_F/V_{OUT} = 3.5V_{DC}$ note 4	120	160	250	$\mu\text{A}$
	$V_{CC} = 6V_{DC}$				
Leakage Current I <sub>pin 3</sub>	$I_{CCP} = 0; V_F/V_{OUT} = 0$			0.1	$\mu\text{A}$
Gain Constant K	note 3	0.9	1.0	1.1	
Non-Linearity	note 5	-1.0	+0.3	+1.0	%
<b>■ Op. Amp.</b>					
Input Offset Voltage					
CS-2907 Series	$V_{IN} = 6V_{DC}$		3	10	mV
CS-2917 Series	$V_{IN} = 3.5V_{DC}$		3	10	mV
Input Bias Current					
CS-2907 Series	$V_{IN} = 6V_{DC}$		0.05	0.5	$\mu\text{A}$
CS-2917 Series	$V_{IN} = 3.5V_{DC}$		0.05	0.5	$\mu\text{A}$
Common Mode Voltage		0		$V_{CC} - 1.5$	V
Open Loop Gain			200		V/mV
I <sub>SINK</sub>	$V_{OUTC} = 1V$	40	50		mA
I <sub>SOURCE</sub>					
CS-2907 Series	$V_{OUTE} = V_{CC} - 2V$		10		mA
CS-2917 Series	$V_{OUTE} = V_{CC} - 2V; V_{CC} = 6V_{DC}$		10		mA
Saturation Voltage	$I_{SINK} = 5\text{mA}$		0.1	0.5	V
	$I_{SINK} = 20\text{mA}$			1.0	V
	$I_{SINK} = 50\text{mA}$		1.0	1.5	V
<b>■ Zener Regulator (CS-2917 Series Only)</b>					
Regulator Voltage	Dropping Resistor = $470\Omega$		7.56		V
Series Resistance			10.5	15	$\Omega$
Temperature Stability			+1		mV/ $^\circ\text{C}$
<b>■ Supply</b>					
Current, Quiescent					
CS-2907 Series	$V_{CC} = 12V_{DC}$		3.8	6.0	mA
CS-2917 Series	$V_{CC} = 6V_{DC}$	3.0	6.0		mA

Notes:

1. Above 25°C Derate at 8.0mW/°C for package D<sub>14</sub> and at 10.0mW/°C for package D<sub>8</sub>.
2. Hysteresis is the sum +V<sub>IH</sub>-(V<sub>IH</sub>), offset voltage is their difference.
3. V<sub>OH</sub> is equal to 3/4 x V<sub>CC</sub> - 1V<sub>BE</sub>, V<sub>OL</sub> is equal to 1/4 x V<sub>CC</sub> - 1V<sub>BE</sub> therefore V<sub>OH</sub> - V<sub>OL</sub> = V<sub>CC</sub>/2. The difference, V<sub>OH</sub> - V<sub>OL</sub>, and the mirror gain, I<sub>2</sub>/I<sub>3</sub>, are the two factors that cause the tachometer gain constant to vary from 1.0.
4. Be sure when choosing the time constant R<sub>1</sub> x C<sub>1</sub> that R<sub>1</sub> is such that the maximum anticipated output voltage at F/V<sub>OUT</sub> can be reached with I<sub>3</sub> x R<sub>1</sub>. The maximum value for R<sub>1</sub> is limited by the output resistance of F/V<sub>OUT</sub> which is greater than 10MΩ typ.
5. Nonlinearity is defined as the deviation of V<sub>OUT</sub> (@ F/V<sub>OUT</sub>) for f<sub>IN</sub> = 5kHz from a straight line defined by the V<sub>OUT</sub> @ 1kHz and V<sub>OUT</sub> @ 10kHz, C<sub>1</sub> = 1000pF, R<sub>1</sub> = 68kΩ and C<sub>2</sub> = 0.22μF.

Package Pin Description

PACKAGE PIN #		PACKAGE PIN #		PIN SYMBOL	FUNCTION
8L PDIP CS-2907	CS-2917	14L PDIP CS-2907	CS-2917		
1	1	1	1	FREQ <sub>IN</sub>	Analog input signal from speed sensor.
		11	11	COMP-	Inverted input to comparator; connected to Gnd in D8.
2	2	2	2	C <sub>CP</sub>	Charge pump capacitor.
3	3	3	3	F/V <sub>OUT</sub>	Charge pump output, the charge on the capacitor is measured at the output.
4	4	5	5	OUT <sub>E</sub>	Emitter of op amp's output stage.
5	5	8	8	OUT <sub>C</sub>	Collector of op amp's output stage.
6	6	9	9	V <sub>CC</sub>	Supply voltage.
		4	4	IN+	Positive input to op amp.
7	7	10	10	IN-	Negative input to op amp.
		6, 7, 13, 14	6, 7, 13, 14	NC	No connection.
8	8	12	12	Gnd	Ground connection.

Applications

A timing capacitor C<sub>CP</sub>, an output resistor R<sub>F</sub>, and an output filter capacitor C<sub>F</sub>, are required as shown in Figure 1. On each transition of the input comparator, C<sub>P</sub> is linearly charged or discharged between voltage limits V<sub>H</sub> and V<sub>L</sub>. The difference, V<sub>H</sub>-V<sub>L</sub>, equals V<sub>CC</sub>/2. During one half cycle of input frequency, the change in charge on C<sub>CP</sub> is: C<sub>CP</sub> V<sub>CC</sub>/2. The average charge-pump current charging C<sub>CP</sub> during one half cycle of input frequency = C<sub>CP</sub> V<sub>CC</sub> F<sub>IN</sub> where F<sub>IN</sub> = input frequency. This charge pump current, I<sub>C</sub>, is accurately mirrored into R<sub>F</sub> to generate a DC voltage at F/V<sub>OUT</sub> such that V<sub>F</sub>/V<sub>OUT</sub> = I<sub>C</sub>R<sub>F</sub> = K R<sub>F</sub>C<sub>CP</sub> V<sub>CC</sub> F<sub>IN</sub> where K is a circuit constant typically equal to one. Averaging, or filtering is accomplished with C<sub>F</sub> and both output ripple voltage and response time are dependent on the value of C<sub>p</sub> Peak to peak ripple voltage V<sub>R</sub> = (V<sub>CC</sub>/2) (C<sub>CP</sub>/C<sub>F</sub>) (1-F<sub>IN</sub>/F<sub>max</sub>) where F<sub>max</sub> = 12/(C<sub>CP</sub> V<sub>CC</sub>) and I<sub>F</sub> is the current in C<sub>F</sub>.

For the 2917 series on-board shunt-regulator an external resistor R<sub>2</sub> is required for operation from the input supply voltage.

The value of R<sub>F</sub> does not therefore affect ripple; however if it is too large by comparison with the output impedance

seen at F/V<sub>OUT</sub>, linearity will be adversely affected. Since the current at F/V<sub>OUT</sub>, I<sub>F</sub>/V<sub>OUT</sub>, is internally set, R<sub>F</sub> must be chosen such that V<sub>F</sub>/V<sub>OUT</sub> max. = I<sub>F</sub>/V<sub>OUT</sub>R<sub>F</sub>.

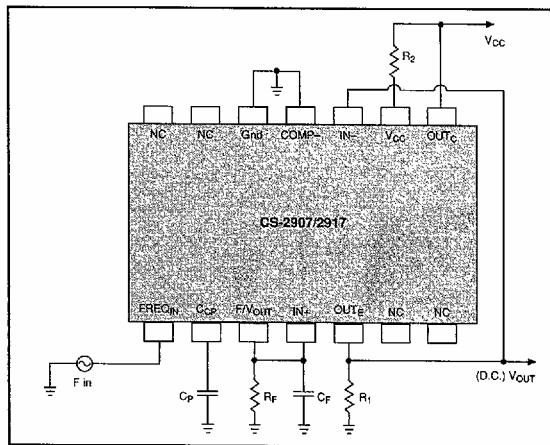

Figure 1: Application Diagram

The CS-2917 F-to-V converter integrated circuit, with built-in operational amplifier, regulator, and output transistor is ideal for tachometer feedback motor speed control applications. Two typical application circuits are shown in Figure 2. Figure 2A employs the CS-2907-N14 operating from the  $V_{CC}$  line. Figure 2B offers an alternative approach using the CS-2917-N8 operating from the  $V_{CC}$  line and using the internal regulator. In both circuits, the tachometer feedback-signal is applied to the comparator input, and the F-to-V conversion gain is set by  $C_{CP}R_F$ . The general purpose op amp is used both as a summing node for the speed reference input (from potentiometer  $R_T$ ), and as a frequency compensated integrator which provides zero steady state speed error under varying load

conditions. Capacitors  $C_2$  and  $C_3$  provide the integrating function at low frequency while  $R_2$  and  $C_2$  provide the frequency compensation which insures loop stability. In Figure 2A, the on-chip driver transistor drives a discrete power transistor which in turn drives the motor. In Figure 2B, the on-chip driver transistor is used as an inverting gain stage to close the loop around the op amp, and the provide drive voltage for the discrete NPN darlington transistor which drives the motor.

Both of these approaches provide accurate regulation of motor speed under conditions of varying motor load,  $V_{CC}$  and ambient temperature.

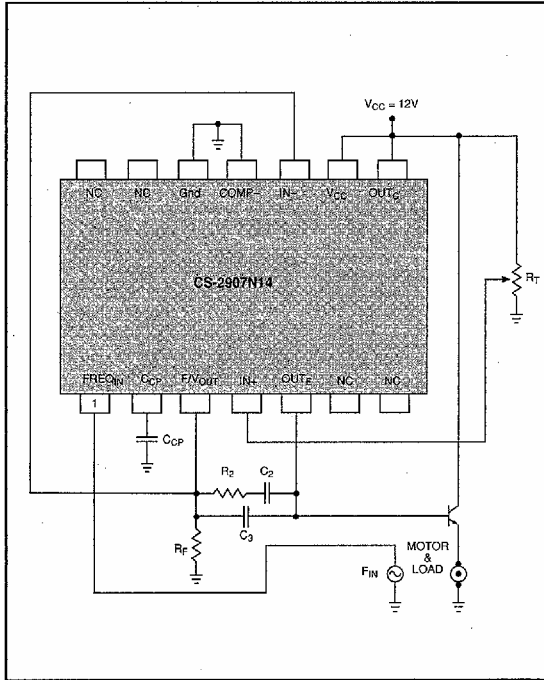

Figure 2A: Motor Speed Control with CS-2907N14.

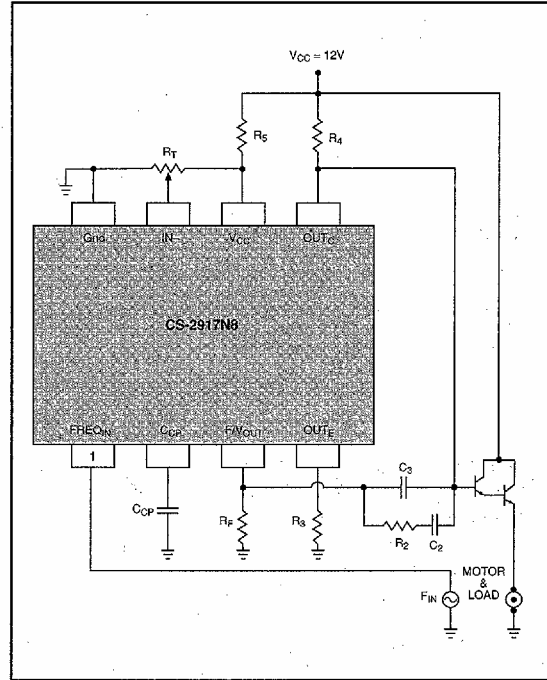

Figure 2B: Motor Speed control with CS-2917N8.

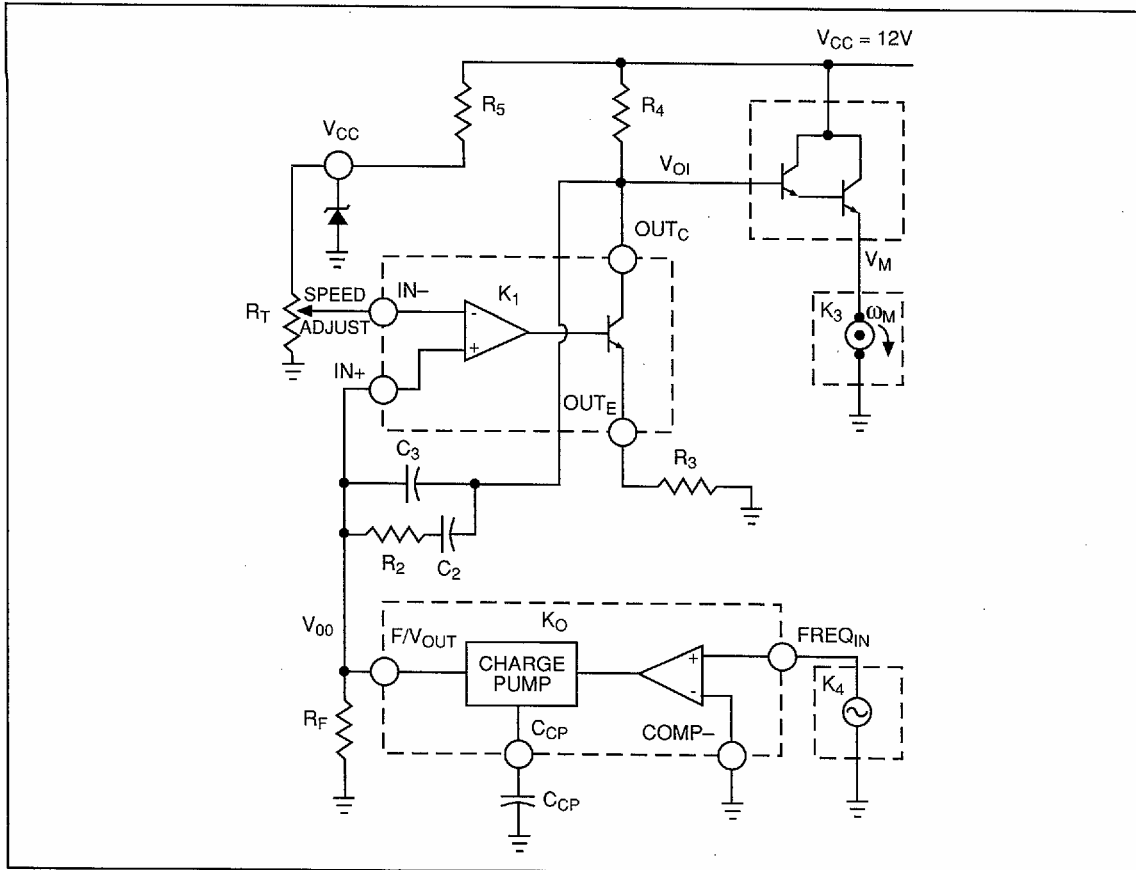

Figure 3: Motor Speed Control Block Diagram of CS-2917N8.

Figure 3 is the circuit of Figure 2B re-drawn in a block diagram form which lends itself to visualization and analysis of the regulator loop. (Figure 2A can be analyzed in the same manner.) Potentiometer  $R_T$  provides the loop reference input. The op amp integrator, the power darlington and the motor provide the forward gain components  $K_1$ ,  $K_2$  and  $K_3$ . The tachometer and F-to-V converter provide the gain components  $K_4$  and  $K_0$  in the feedback path. We will now derive the transfer functions for all components of the loop, write the expression for loop gain, and compute component values to insure loop stability.

A.  $K_0$  is the transfer function for the F-to-V converter.

$$1. \quad K_0 \frac{V_{00}}{f_{IN}} = KV_R R_F C_{CP}; \quad K = 1.0; \quad V_R = 7.6V$$

B.  $K_1$  is the transfer function for the integrator.

$$2. \quad K_1 = \left| \frac{V_{01}}{V_{00}} \right| = \frac{1 + j\omega R_2 C_2}{j\omega R_F (C_2 + C_3) \left[ 1 + \frac{j\omega C_2 C_3 R_2}{C_2 + C_3} \right]}$$

This transfer function has the following poles and zeros:

$$\text{Zero at: } \omega_1 = \frac{1}{R_2 C_2}$$

Pole at:  $\omega = 0$  (an integrator)

$$\text{Pole at: } \omega_2 = \frac{C_2 + C_3}{R_2 C_2 C_3}$$

C.  $K_2$  is the transfer function of the power darlington transistor. Assume it equals 0.9 over the frequency range of interest.

$$3. \quad K_2 = \frac{V_m}{V_{01}} = 0.9$$

D.  $K_3$  is the transfer function of the motor. (See Electrocraft Engineering Handbook, 4th edition, Pg. 2-19, eq. 2.3.28.)

$$4. \quad K_3 = \frac{\omega_m}{V_m} = \frac{1/K_E}{(1 + j\omega J_m)(1 + j\omega I_m)}$$

$\omega_m$  = Motor Rotational Speed (rad/sec)

$V_m$  = Applied Motor Voltage

$I_m = (R_A I_T / K_T K_T) = \text{Mechanical Time Constant}$

- $J_e = (L_A/R_A) =$  Electrical Time Constant
- $K_T =$  Motor Torque Const. (oz • in/A)
- $K_E =$  Motor Back EMF Const. (V/rad/sec)
- $R_A =$  Motor Armature Resistance (ohms)
- $L_A =$  Motor Armature Inductance (henrys)
- $J_T =$  Total Inertial Load on Motor (oz, • in • sec<sup>2</sup>)

This design example describes an application using a small, permanent-magnet fractional-horsepower d.c. motor driving an inertial load. The following parameter values are taken from manufacturer's data for the motor and from laboratory measurements on the drive system.

- $\omega_m = 314.2$  rad/sec (3000 rpm)
- $K_T = 2.1$ oz. in/A =  $14.83 \times 10^{-3}$  N.M/A
- $K_E = 14.83 \times 10^{-3}$  V/rad/sec
- $R_A = 6.9\Omega$
- $J_e = 0.7$  msec
- $\therefore L_A = 4.83$  mh, and
- $J_T = 9.39 \times 10^{-4}$  oz•in•SEC<sup>2</sup>
- $= 6.63 \times 10^{-6}$  kg•m<sup>2</sup>

5.  $J_m = \frac{R_A J_T}{K_E K_T} = 0.208$  sec

$\omega_B = \frac{1}{J_m} = 4.8$  rad/ sec

$f_B = 0.765$ Hz

$\omega_e = \frac{1}{J_e} = 1429$  rad/sec

$f_e = 227$ Hz

$1/K_e = 67.4$

6.  $K_3 = \frac{\omega_m}{V_m} = \frac{67.4}{\left(1 + j \frac{\omega}{4.8}\right) \left(1 + j \frac{\omega}{1429}\right)}$

Ignoring the electrical time constant (assumes that the loop crossover frequency is less than 1429 rad./sec.) we have:

7.  $K_E = \frac{\omega_m}{V_m} = \frac{67.4}{\left(1 + j \frac{\omega}{4.8}\right)}$

E.  $K_4$  is the tachometer constant.

$\omega_m K_4 = f_{in}$   
for  $f_{in} = 400$  Hz;  $\omega_m = 314.2$  rad/sec and

8.  $K_4 = 1.273$  cyc/rad

The loop gain,  $A_L$ , equals.

9.  $A_L = K_0 K_1 K_2 K_3 K_4$  at  $\omega = 1$  rad/sec, for

$1 < W_B < W_L < W_Z$

$A_L (\omega = 1)$

$= 7.6(R_1 C_1) \frac{1}{R_F(C_2 + C_3)} (0.9)(67.4)(1.273)$

Arbitrarily selecting a loop gain of 50 (34db) at  $\omega = 1$  rad/sec, we derive the following expression:

$\frac{C_{CP}}{C_2 + C_3} = \frac{50}{(7.6)(0.9)(67.4)(1.273)} = 0.0852$

10.  $C_2 + C_3 = 11.74 C_1$

Now, select  $R_1 C_1$  to set the loop reference voltage to about 1/2 of the on-chip zener reference voltage:

11.  $K_4 \omega_m \cdot K_0 = V_{REF} \approx 7.6/2$

By selecting standard values for  $C_{CP}$  and  $R_F$ ,  $C_{CP} = 0.01\mu F$  and  $R_F = 146k\Omega$ , the reference voltage at the loop operating point is:

12.  $V_{REF} = (314.2 \text{ rad/sec}) (7.6) (1.0) (0.01\mu F)$   
 $(146k) (1.273) = 4.4$  volts

4.4 volts is well within the regulated supply tolerance and should present no adjustment problem in production.

Now, plot the bode diagram for the loop with only the integrator response and motor break frequency,  $f_B = 0.765$ Hz and determine suitable locations for  $f_1$  and  $f_2$  such that the compensated bode plot crosses the unity gain axis at about the mid point of the -6db/octave line segment connecting  $f_1$  and  $f_2$ . Selecting  $f_1 = 1.5$ Hz, and  $f_2 = 7.0$ Hz we have; (see Figure 4)

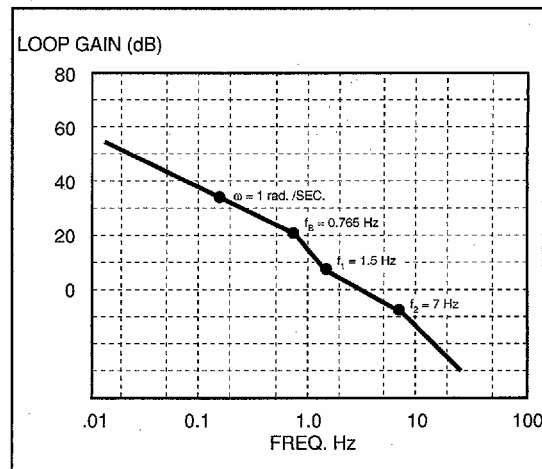

Figure 4.

$$f_1 = \frac{1}{2\pi R_2 C_2} = 1.5\text{Hz}$$

$$f_2 = \frac{C_2 + C_3}{2\pi R_2 C_2 C_3} = 7.0\text{Hz}$$

$$\frac{f_1}{f_2} = \frac{C_3}{C_2 + C_3} = 0.214$$

$$C_3 = 0.214 (C_2 + C_3)$$

From Equation 10

$$C_2 + C_3 = 11.74 C_{CP} = 0.1174\mu\text{F}$$

$$C_3 = (0.214) (0.1174) = 0.025\mu\text{F}$$

Select  $C_3 = 0.022\mu\text{F}$

and  $C_2 = 0.1\mu\text{F}$

Then;

$$R_2 = \frac{1}{2\pi f_1 C_2} = 1\text{M}\Omega$$

Resistors  $R_3$  and  $R_4$  are chosen to bias the on-chip drive transistor in a linear region at the desired motor speed. To maintain closed loop stability of the integrator we keep the inverting gain of this stage close to unity. For this application  $R_3 = 570\Omega$  and  $R_4 = 1000\Omega$ . A  $470\Omega$  resistor is selected for  $R_5$  to provide sufficient zener bias from the 12V supply. The component list for the circuit in Figure 2B is:

$$R_F = 146\text{k}\Omega \quad C_{CP} = 0.01\mu\text{F}$$

$$R_2 = 1\text{M}\Omega \quad C_2 = 0.1\mu\text{F}$$

$$R_3 = 510\Omega \quad C_3 = 0.022\mu\text{F}$$

$$R_4 = 1000\Omega$$

$$R_5 = 470\Omega$$

$$R_T = 100\text{k}\Omega$$

This design example illustrates a method for computing component values to insure closed loop stability of the motor speed regulator system. It is based on an application circuit which includes an integrator to provide for zero steady state error under varying load conditions. This system, with loop gain equal to 50 at  $\omega$  equals 1 rad/sec gave acceptable static and dynamic performance for the intended application.

Package Specification

PACKAGE DIMENSIONS IN mm (INCHES)

Lead Count	D			
	Metric		English	
	Max	Min	Max	Min
8L PDIP	9.40	9.14	.370	.360
14L PDIP	19.18	18.92	.755	.745

PACKAGE THERMAL DATA

Thermal Data		8 Lead PDIP	14 Lead PDIP	
$R_{\theta JC}$	typ	52	48	$^{\circ}C/W$
$R_{\theta JA}$	typ	100	85	$^{\circ}C/W$

8L and 14L PDIP: 300 mil wide

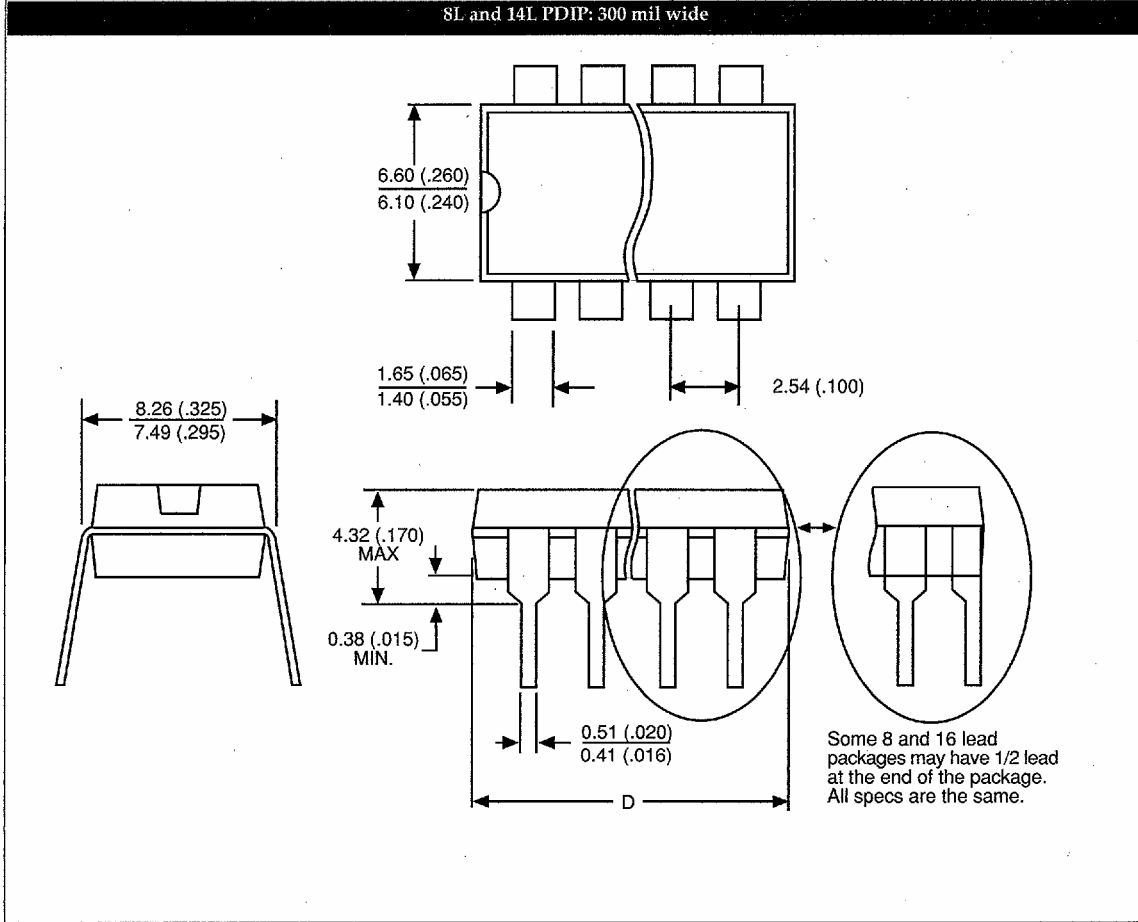

Ordering Information

Part Number	Description
CS-2907N14	14 Lead PDIP
CS-2907N8	8 Lead PDIP
CS-2917N14	14 Lead PDIP
CS-2917N8	8 Lead PDIP

This datasheet has been downloaded from:

[www.DatasheetCatalog.com](http://www.DatasheetCatalog.com)

Datasheets for electronic components.



LittleDiode supplies new, hard to find or obsolete electronic components and semiconductors all over the world.

With over two million different components listed you are sure to find the part you need.

Feel free to visit us today at our online store:

[LittleDiode.com](http://LittleDiode.com)

Looking forward to providing you with the best possible service.