

SONY**CXK1012P****1024-bit (128word x 8bit) Non-volatile Memory****Description**

The CXK1012P is an electrically erasable and programmable E²PROM of 128word x 8 bit structure. It employs non-volatile memory transistors of the MNOS type. For the Input/Output, serial transmission of the data is executed. The built-in charge pump circuit permits all operations with a mere 5V power supply. With the built-in timer external parts are not required anymore, while Erasure and Write are conducted automatically. It is most suitable for the non-volatile channel memory of electronic tuners, for use instead of DIP switching as well as with the setting of various fixed numbers, or for the read only memory system necessary to rewrite immediately on the field.

Features

- Single 5V power supply
- 128 word x 8 bit of full decoding structure
- Serial data transmission
- Rewritable in 1-word unit and in one chip
- Memory retention time of more than 10years with no power supply
- Number of erasures and writings: more than 10⁵ times
- TTL IC direct drive is possible
- low power consumption (35 mW Typ.)

Structure

P-channel MNOS IC

Package Outline

Unit: mm

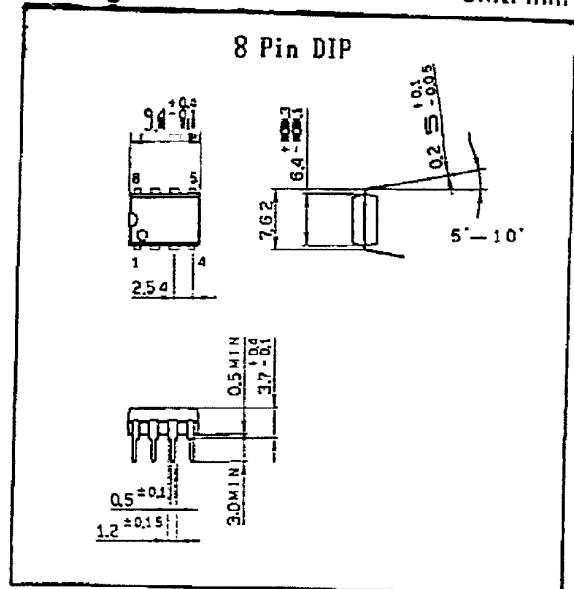

To: Jun's Sipasa
FM: Kerstin Weber

Application Circuit

1) Using internal timer circuit

(In the example a serial port is used. A general port may also be used. It is also possible to refrain from using $\overline{\text{BUSY}}$ pin.)

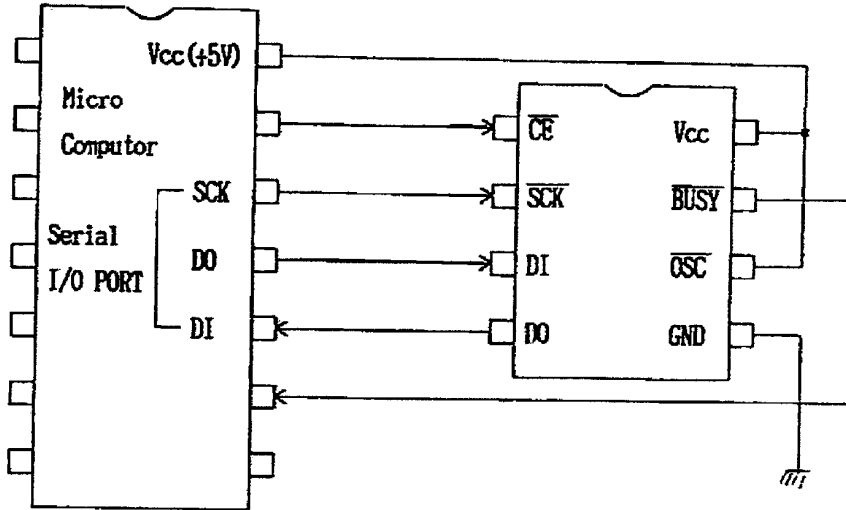

2) Using external control

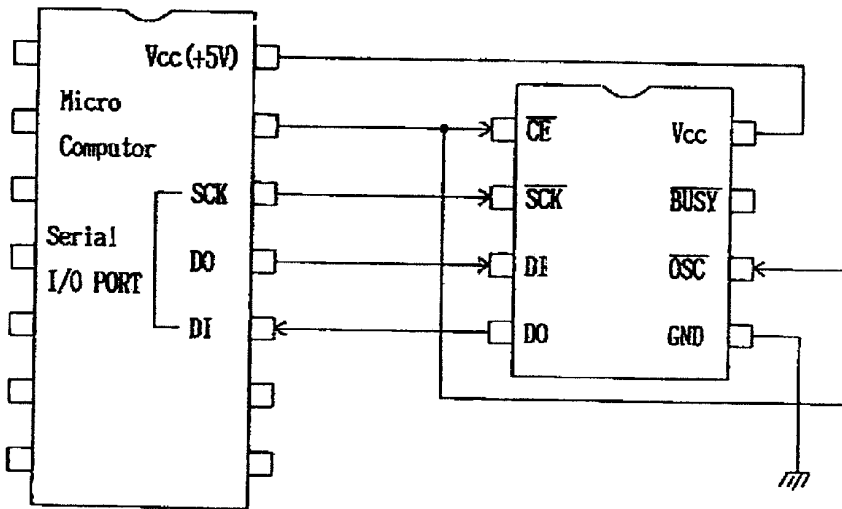

Input/Output Timing Chart

INPUT MODE

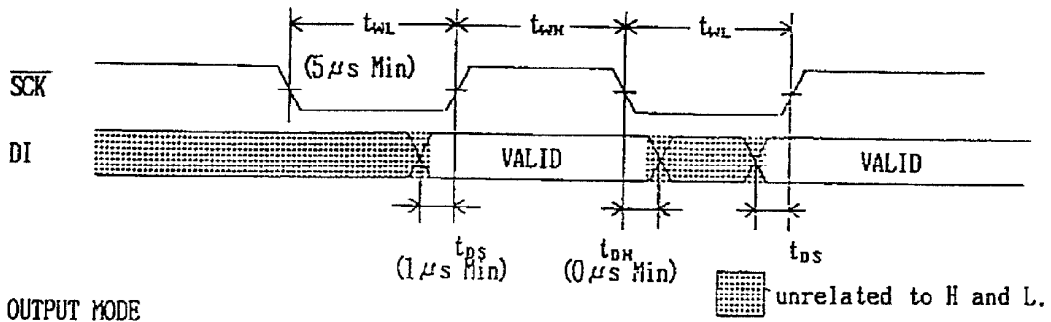

OUTPUT MODE

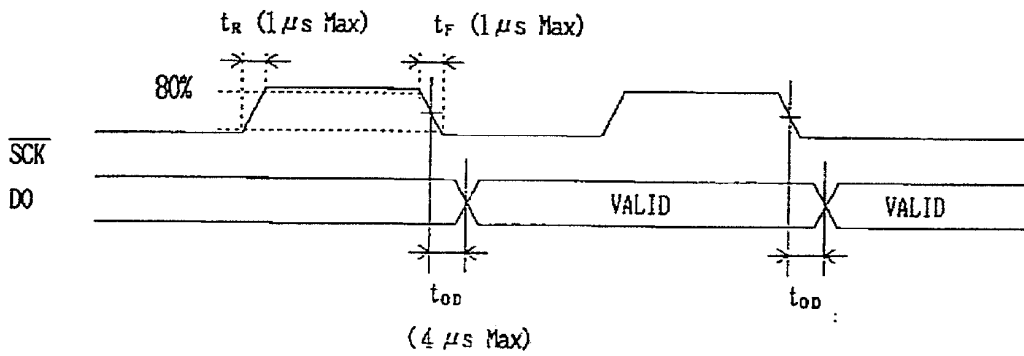

CE TIMING 1 (DR MODE)

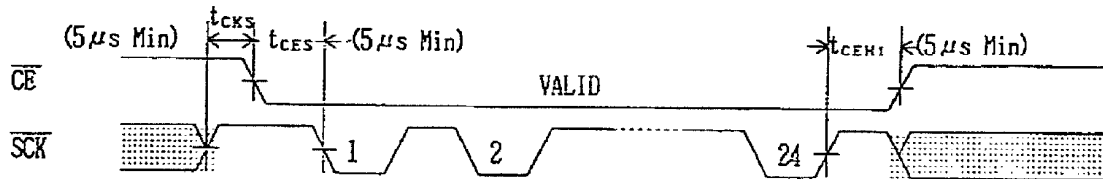

CE TIMING 2 (DW, ALDW MODE, INTERNAL TIMER)

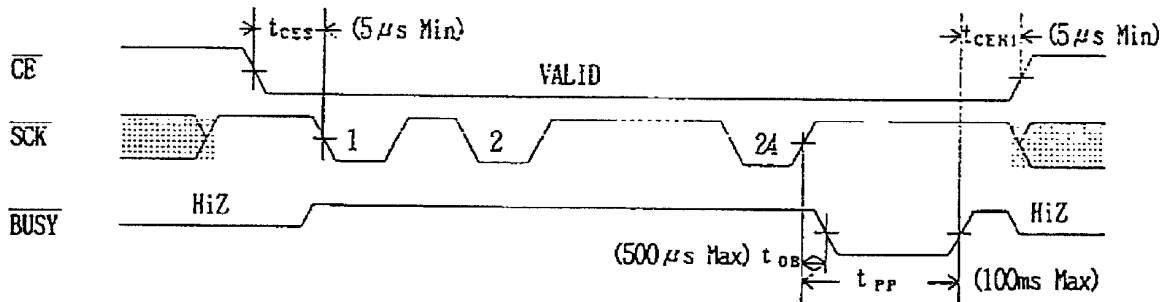

CE TIMING 3 (DW, ALDW MODE, EXTERNAL CONTROL)

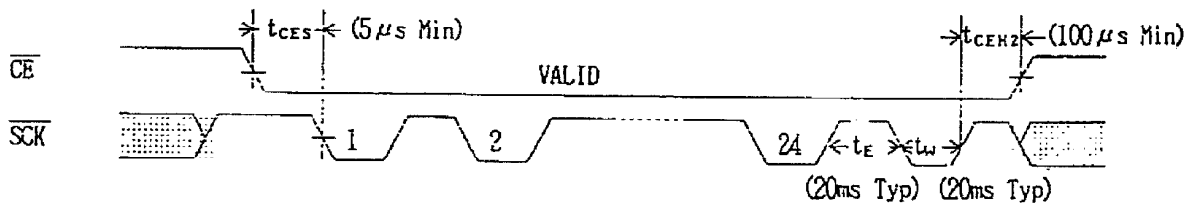

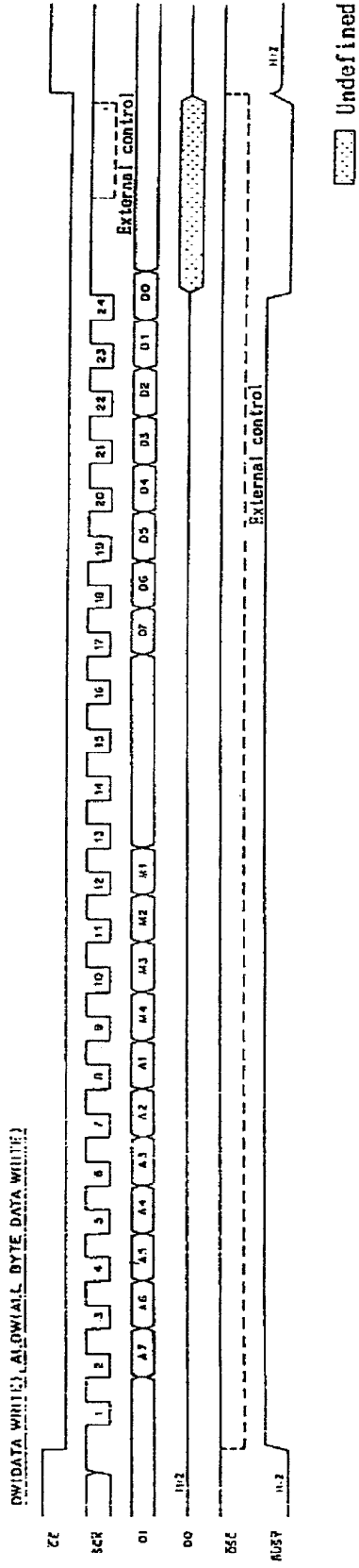
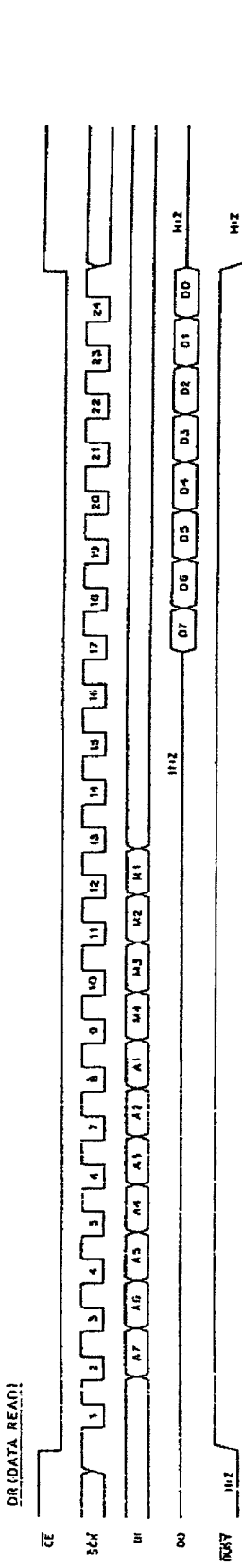

Pin Description

No.	Type	Symbol	Description
1	IN	\overline{CE}	Chip enable input pin
2	IN	\overline{SCK}	Sync clock input pin
3	IN	DI	Data input pin
4	OUT	DO	Data output pin
5	Power	GND	Power supply pin (Normally 0V)
6	IN	\overline{OSC}	Oscillation pin (When using internal circuit, Open or fixed to V_{CC})
7	OUT	\overline{BUSY}	BUSY signal output pin
8	Power	V_{CC}	Power supply pin (Normally +5V)

Electrical Characteristics 1.

(Ta=-40 to +85°C, $V_{CC}=5V \pm 10\%$, GND=0V)

Item	Symbol	Name	Condition	Min.	Typ.	Max.	Unit
Power supply current	I_{CC}		*1		6.5	12	mA
Input pull-up current	I_{IU}	$\overline{CE}, \overline{SCK}, DI, \overline{OSC}$	$V_{IN}=0V$	-30	-60	-180	μA
Output leakage current	I_{OLK}	DO, \overline{BUSY}				± 10	μA
Output voltage "High" level 1	V_{OH1}	DO	$I_{OH} = -400 \mu A$	2.4			V
Output voltage "Low" level 1	V_{OL1}	DO	$I_{OL} = 1.6mA$			0.4	V
Output voltage "High" level 2	V_{OH2}	\overline{BUSY}	$I_{OH} = -400 \mu A$	2.4			V
Output voltage "Low" level 2	V_{OL2}	\overline{BUSY}	$I_{OL} = 400 \mu A$ *2			0.4	V

*1. Including during Erase and Write.

*2. See Fig.2.

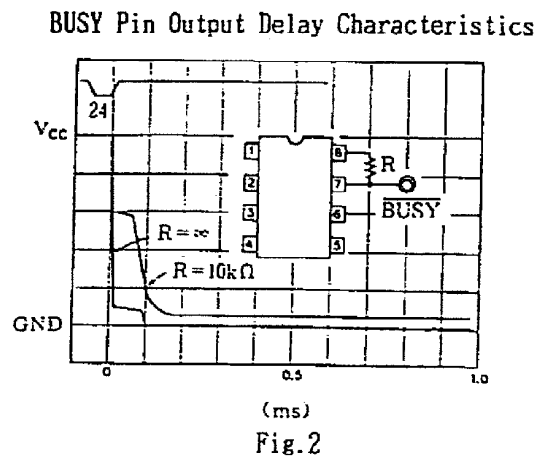
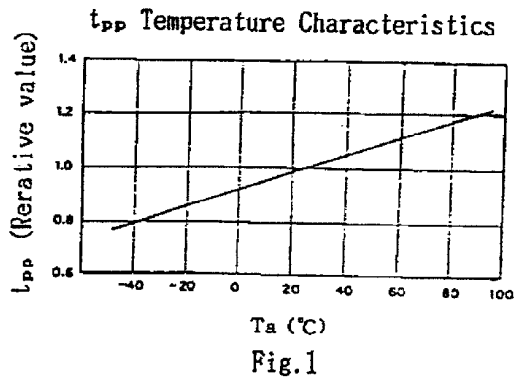

DO Pin Output Characteristics (Typ.)

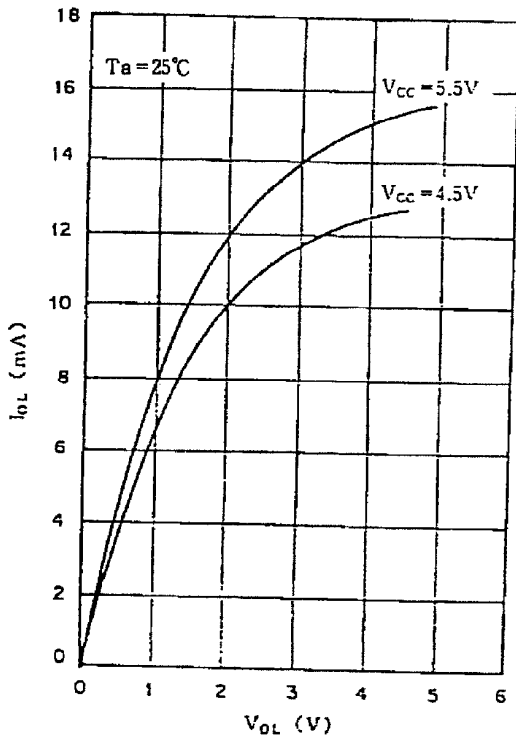
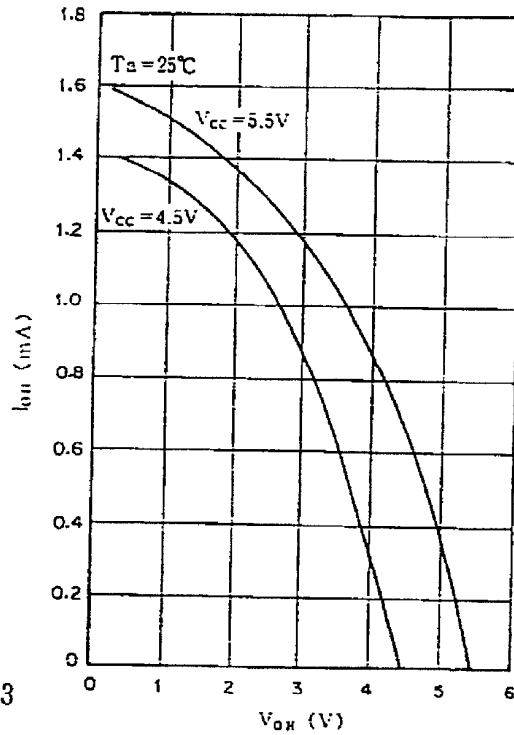
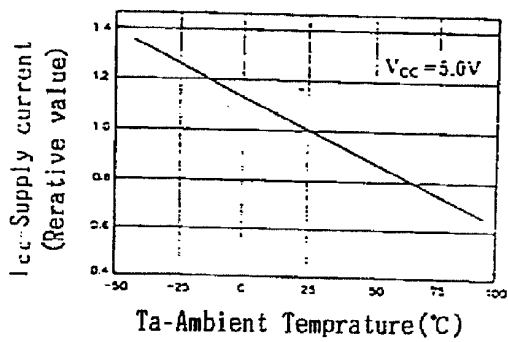

Fig. 3



Supply Current Temperature Characteristics



Electrical Characteristics 2

(Ta=-40 to +85°C, Vcc=5V ±10%, GND=0V)

Item	symbol	Condition	Min.	Typ.	Max.	Unit
Clock pulse width	t _{WH}		5			μs
Colck pulse width	t _{WL}		5			μs
Data input setup time	t _{DS}		1			μs
Data input hold time	t _{DH}		0			μs
Rise /Fall time	t _r , t _f				1	μs
Chip enable setup time	t _{CES}		5			μs
Chip enable hold time 1	t _{CEH1}		5			μs
Chip enable hold time 2	t _{CEH2}		100			μs
Clock set up time	t _{CXS}		5			μs
Data delay time	t _{DD}	DO, C _L =100pF			4	μs
BUSY output delay time*3	t _{BD}	BUSY, R=10kΩ			500	μs
Number of Read	N _R	Refresh period	10 ⁷	10 ⁹		time
Program time	t _{PR}	During internal timer usage *1		40	100	ms
Erasure time	t _E	During external control *2	16	20	100	ms
Write time	t _W	During external control *2	16	20	100	ms
Memory retention time 1	t _{MH1}	After rewriting 10 ⁴ times, store at Ta=85°C	10			year
Memory retention time 2	t _{MH2}	After rewriting 10 ⁵ times, store at Ta=85°C	1			year

*1. Including the value when Ta= 25°C (See fig.1)

*2. Usage of ranges t_E to t_W (16 to 100ms) presents no problem for Erasure and Write in functions

*3. See Fig.2.

Command Table

M4	M3	M2	M1	Operational Command
0	0	0	0	No operation
0	0	1	0	DW: Memory Write
0	1	0	0	ALDW:A'1 byte write
0	1	1	0	Test Mode ,Usage forbidden
1	0	0	0	No operation
1	0	1	0	DR: Memory Read
1	1	0	0	Test mode, Usage forbidden
1	1	1	0	Test mode, Usage forbidden
X	X	X	1	Test mode, Usage forbidden

Description of Circuit Operations

1) Timing

At the rise time of Sync clock (\overline{SCK}), data is taken in from D1 and with the fall time, data is output from D0. Input data should be stabilized, from \overline{SCK} rise time and before 1 μ s.

2) DR: Data Read (Memory Read)

\overline{CE} is set to L and then the first clock is input after 5 μ s. By entering address data (A7 to A1) and mode data (M4 M3 M2 M1=1010), from the 17th clock and in synchronization with the fall time, D7 D6 through D0 are output in the respective order. When the rise time of the 24th clock has taken place, set \overline{CE} to H after 5 μ s.

3) DW: Data Write (Memory Write)

\overline{CE} is set to L and then the first clock is input after 5 μ s. By entering Address data (A7 to A1), mode data (M4 M3 M2 M1=0010) and Data (D7 to D0), from the rise time of the 24th clock, Erasure and Write are performed automatically. As \overline{BUSY} pin outputs L during Erasure and Write and H at the completion of Write, set \overline{CE} to H following H output and after 5 μ s.

When \overline{BUSY} pin is not in use, set \overline{CE} to H after 100ms (t_{pp} Max.)

4) ALDW: All Byte Data Write

By entering Mode Data (M4 M3 M2 M1=0100), Write operation of the same data (D7 to D0) is carried out simultaneously to all addresses. \overline{CE} timing and \overline{BUSY} output are the same as in above article 3).

5) Electrical control of Erasure and Write

Erasure and Write pulses are generated by the built-in C and R. However, external control is also possible. By setting \overline{OSC} pin to L in DW or ALDW modes, Erasure and Write control are possible through the usage of \overline{SCK} pin. Erasure is carried out during t_e (20ms Typ.) and write during t_w (20ms Typ.).

By setting \overline{SCK} pin to H after the lapse of t_w , write complete pulse is generated. However the actual completion takes place about 50 μ s after the pulse generation,

(50 μ s Typ, 100 μ s Max.) At that time \overline{BUSY} pin changes from L to H. Over 5 μ s after it has turned to H, set \overline{CE} pin to H. When \overline{BUSY} pin is not in use, after \overline{SCK} pin has turned from L to H (t_w) by over 100 μ s, set \overline{CE} to H.

Absolute Maximum Ratings (GND = 0V)

• Supply voltage	V_{CC}	-0.3	to	+7.0	V
• Input voltage	V_{IN}	-0.3	to	$V_{CC} + 0.3$	V
• Operating temperature	T_{OPR}	-40	to	+85	°C
• Storage temperature	T_{STG}	-55	to	+150	°C

Recommended Operating Conditions ($T_a = -40$ to $+85$ °C, GND=0V)

• Supply voltage	V_{CC}	4.5	to	5.5	V
• Clock frequency	f_{CLK}	DC	to	100	kHz
• High level input voltage	V_{INH}	$0.7 V_{CC}$	to	V_{CC}	V
• Low level input voltage	V_{INL}	0	to	$0.3 V_{CC}$	V

Block Diagram and Pin Configuration

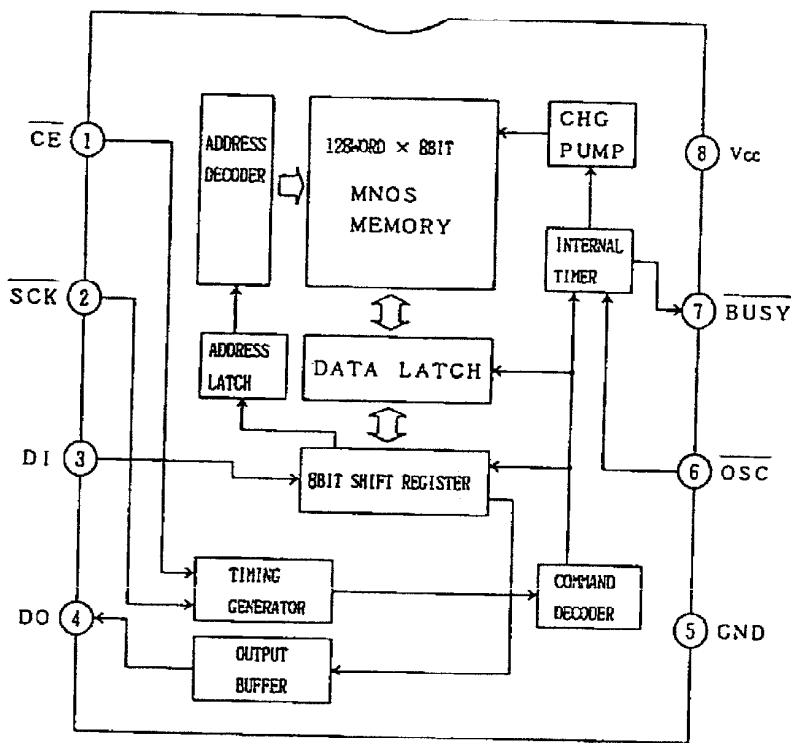

6) Usage of ALDW mode H.

Write is carried out to the Memory elements according to the 「Erase」→「Write」 cycle. During normal write procedures (DW mode), as write is executed for all the 128 address, $128 \times t_{pp}$ (or $t_E + t_W$) = 5.12sec (Typ.)

amount of time is necessary.

With the CXK1012P, 「Erasure state」 and 「Data "0"」 are made to correspond. Once "0" has been written into all addresses (Erasure state), by writing data into each address, the program time can be shortened.

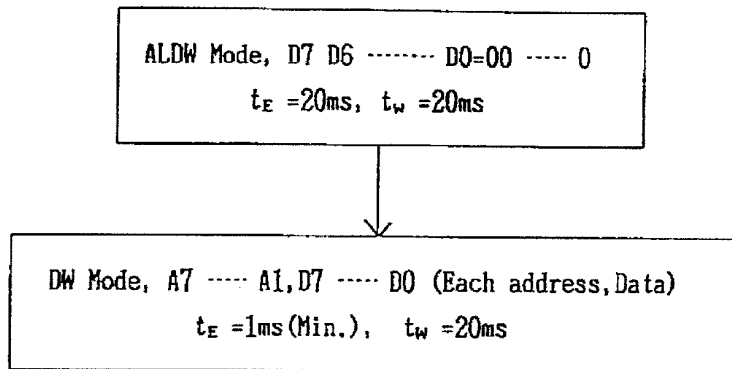

In this case, the program time becomes.

$$(20\text{ms} + 20\text{ms}) + 128 \times (1\text{ms} + 20\text{ms}) = 2.73\text{sec}$$

This datasheet has been downloaded from:

www.DatasheetCatalog.com

Datasheets for electronic components.



LittleDiode supplies new, hard to find or obsolete electronic components and semiconductors all over the world.

With over two million different components listed you are sure to find the part you need.

Feel free to visit us today at our online store:

LittleDiode.com

Looking forward to providing you with the best possible service.