



CY7C130/CY7C131 CY7C140/CY7C141

1K x 8 Dual-Port Static Ram

Features

- True Dual-Ported memory cells which allow simultaneous reads of the same memory location
- 1K x 8 organization
- 0.65-micron CMOS for optimum speed/power
- High-speed access: 15 ns
- Low operating power: I_{CC} = 90 mA (max.)
- Fully asynchronous operation
- Automatic power-down
- Master CY7C130/CY7C131 easily expands data bus width to 16 or more bits using slave CY7C140/CY7C141
- **BUSY** output flag on CY7C130/CY7C131; **BUSY** input on CY7C140/CY7C141
- **INT** flag for port-to-port communication
- Available in 48-pin DIP (CY7C130/140), 52-pin PLCC and 52-pin TQFP
- Pin-compatible and functionally equivalent to IDT7130/IDT7140

Functional Description

The CY7C130/CY7C131/CY7C140 and CY7C141 are high-speed CMOS 1K by 8 dual-port static RAMs. Two ports are provided permitting independent access to any location in memory. The CY7C130/ CY7C131 can be utilized as either a standalone 8-bit dual-port static RAM or as a master dual-port RAM in conjunction with the CY7C140/CY7C141 slave dual-port device in systems requiring 16-bit or greater word widths. It is the solution to applications requiring shared or buffered data, such as cache memory for DSP, bit-slice, or multiprocessor designs.

Each port has independent control pins; chip enable (\overline{CE}), write enable (R/\overline{W}), and output enable (\overline{OE}). Two flags are provided on each port, \overline{BUSY} and \overline{INT} . \overline{BUSY} signals that the port is trying to access the same location currently being accessed by the other port. \overline{INT} is an interrupt flag indicating that data has been placed in a unique location (3FF for the left port and 3FE for the right port). An automatic power-down feature is controlled independently on each port by the chip enable (\overline{CE}) pins.

The CY7C130 and CY7C140 are available in 48-pin DIP. The CY7C131 and CY7C141 are available in 52-pin PLCC and PQFP.

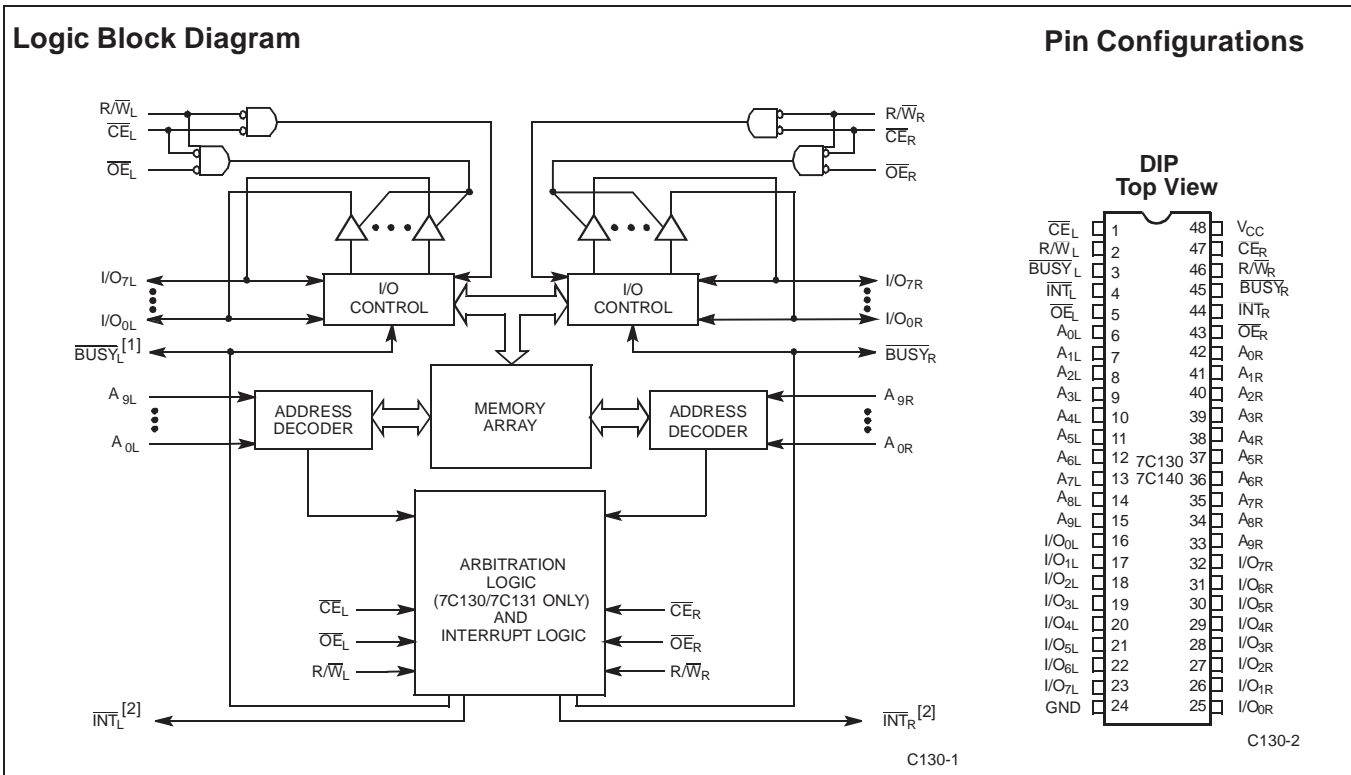

- Notes:**
1. CY7C130/CY7C131 (Master): \overline{BUSY} is open drain output and requires pull-up resistor
CY7C140/CY7C141 (Slave): \overline{BUSY} is input.
 2. Open drain outputs: pull-up resistor required



Electrical Characteristics Over the Operating Range^[6]

Parameter	Description	Test Conditions	7C131-15 ^[3,4] 7C141-15		7C130-30 ^[3] 7C131-25,30 7C140-30 7C141-25,30		7C130-35 7C131-35 7C140-35 7C141-35		7C130-45,55 7C131-45,55 7C140-45,55 7C141-45,55		Unit
			Min.	Max.	Min.	Max.	Min.	Max.	Min.	Max.	
V _{OH}	Output HIGH Voltage	V _{CC} = Min., I _{OH} = -4.0 mA	2.4		2.4		2.4		2.4		V
V _{OL}	Output LOW Voltage	I _{OL} = 4.0 mA		0.4		0.4		0.4		0.4	V
		I _{OL} = 16.0 mA ^[7]		0.5		0.5		0.5		0.5	
V _{IH}	Input HIGH Voltage		2.2		2.2		2.2		2.2		V
V _{IL}	Input LOW Voltage			0.8		0.8		0.8		0.8	V
I _{Ix}	Input Leakage Current	GND ≤ V _I ≤ V _{CC}	-5	+5	-5	+5	-5	+5	-5	+5	μA
I _{OZ}	Output Leakage Current	GND ≤ V _O ≤ V _{CC} , Output Disabled	-5	+5	-5	+5	-5	+5	-5	+5	μA
I _{OS}	Output Short Circuit Current ^[8, 9]	V _{CC} = Max., V _{OUT} = GND		-350		-350		-350		-350	mA
I _{CC}	V _{CC} Operating Supply Current	CE = V _{IL} , Outputs Open, f = f _{MAX} ^[10]	Com'l	190		170		120		90	mA
			Mil					170		120	
I _{SB1}	Standby Current Both Ports, TTL Inputs	CE _L and CE _R ≥ V _{IH} , f = f _{MAX} ^[10]	Com'l	75		65		45		35	mA
			Mil					65		45	
I _{SB2}	Standby Current One Port, TTL Inputs	CE _L or CE _R ≥ V _{IH} , Active Port Outputs Open, f = f _{MAX} ^[10]	Com'l	135		115		90		75	mA
			Mil					115		90	
I _{SB3}	Standby Current Both Ports, CMOS Inputs	Both Ports CE _L and CE _R ≥ V _{CC} - 0.2V, V _{IN} ≥ V _{CC} - 0.2V or V _{IN} ≤ 0.2V, f = 0	Com'l	15		15		15		15	mA
			Mil					15		15	
I _{SB4}	Standby Current One Port, CMOS Inputs	One Port CE _L or CE _R ≥ V _{CC} - 0.2V, V _{IN} ≥ V _{CC} - 0.2V or V _{IN} ≤ 0.2V, Active Port Outputs Open, f = f _{MAX} ^[10]	Com'l	125		105		85		70	mA
			Mil					105		85	

Notes:

6. See the last page of this specification for Group A subgroup testing information.
7. BUSY and INT pins only.
8. Duration of the short circuit should not exceed 30 seconds.
9. This parameter is guaranteed but not tested.
10. At f = f_{MAX}, address and data inputs are cycling at the maximum frequency of read cycle of 1/t_{RC} and using AC Test Waveforms input levels of GND to 3V.

Capacitance^[9]

Parameter	Description	Test Conditions	Max.	Unit
C _{IN}	Input Capacitance	T _A = 25°C, f = 1 MHz,	15	pF
C _{OUT}	Output Capacitance	V _{CC} = 5.0V	10	pF

AC Test Loads and Waveforms

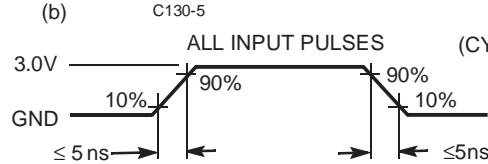
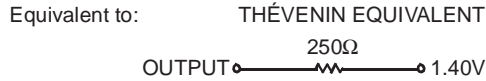
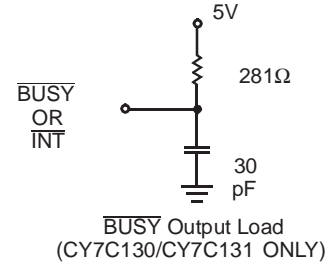
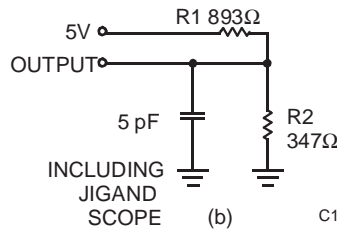
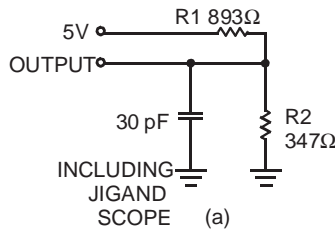

Switching Characteristics Over the Operating Range^[6,11]

Parameter	Description	7C131-15 ^[3,4] 7C141-15		7C130-25 ^[3] 7C131-25 7C140-25 7C141-25		7C130-30 7C131-30 7C140-30 7C141-30		Unit
		Min.	Max.	Min.	Max.	Min.	Max.	
READ CYCLE								
t _{RC}	Read Cycle Time	15		25		30		ns
t _{AA}	Address to Data Valid ^[12]		15		25		30	ns
t _{OHA}	Data Hold from Address Change	0		0		0		ns
t _{ACE}	\overline{CE} LOW to Data Valid ^[12]		15		25		30	ns
t _{DOE}	\overline{OE} LOW to Data Valid ^[12]		10		15		20	ns
t _{LZOE}	\overline{OE} LOW to Low Z ^[9,13, 14]	3		3		3		ns
t _{HZOE}	\overline{OE} HIGH to High Z ^[9,13, 14]		10		15		15	ns
t _{LZCE}	\overline{CE} LOW to Low Z ^[9,13, 14]	3		5		5		ns
t _{HZCE}	\overline{CE} HIGH to High Z ^[9,13, 14]		10		15		15	ns
t _{PU}	\overline{CE} LOW to Power-Up ^[9]	0		0		0		ns
t _{PD}	\overline{CE} HIGH to Power-Down ^[9]		15		25		25	ns
WRITE CYCLE ^[15]								
t _{WC}	Write Cycle Time	15		25		30		ns
t _{SCE}	\overline{CE} LOW to Write End	12		20		25		ns
t _{AW}	Address Set-Up to Write End	12		20		25		ns
t _{HA}	Address Hold from Write End	2		2		2		ns
t _{SA}	Address Set-Up to Write Start	0		0		0		ns
t _{PWE}	R \overline{W} Pulse Width	12		15		25		ns
t _{SD}	Data Set-Up to Write End	10		15		15		ns
t _{HD}	Data Hold from Write End	0		0		0		ns
t _{HZWE}	R \overline{W} LOW to High Z ^[14]		10		15		15	ns
t _{LZWE}	R \overline{W} HIGH to Low Z ^[14]	0		0		0		ns

Notes:

- Test conditions assume signal transition times of 5 ns or less, timing reference levels of 1.5V, input pulse levels of 0 to 3.0V and output loading of the specified I_{OL}/I_{OH} and 30-pF load capacitance.
- AC Test Conditions use V_{OH} = 1.6V and V_{OL} = 1.4V.
- At any given temperature and voltage condition for any given device, t_{HZCE} is less than t_{LZCE} and t_{HZOE} is less than t_{LZOE}.
- t_{LZCE}, t_{LZWE}, t_{HZOE}, t_{LZOE}, t_{HZCE} and t_{HZWE} are tested with C_L = 5pF as in part (b) of AC Test Loads. Transition is measured ±500 mV from steady state voltage.
- The internal write time of the memory is defined by the overlap of CS LOW and R \overline{W} LOW. Both signals must be low to initiate a write and either signal can terminate a write by going high. The data input set-up and hold timing should be referenced to the rising edge of the signal that terminates the write



Switching Characteristics Over the Operating Range^[6,11] (continued)

Parameter	Description	7C131-15 ^[3,4] 7C141-15		7C130-25 ^[3] 7C131-25 7C140-25 7C141-25		7C130-30 7C131-30 7C140-30 7C141-30		Unit
		Min.	Max.	Min.	Max.	Min.	Max.	
BUSY/INTERRUPT TIMING								
t _{BLA}	BUSY LOW from Address Match		15		20		20	ns
t _{BHA}	BUSY HIGH from Address Mismatch ^[16]		15		20		20	ns
t _{BLC}	BUSY LOW from CE LOW		15		20		20	ns
t _{BHC}	BUSY HIGH from CE HIGH ^[16]		15		20		20	ns
t _{PS}	Port Set Up for Priority	5		5		5		ns
t _{WB} ^[17]	R/W LOW after BUSY LOW	0		0		0		ns
t _{WH}	R/W HIGH after BUSY HIGH	13		20		30		ns
t _{BDD}	BUSY HIGH to Valid Data		15		25		30	ns
t _{DDD}	Write Data Valid to Read Data Valid		Note 18		Note 18		Note 18	ns
t _{WDD}	Write Pulse to Data Delay		Note 18		Note 18		Note 18	ns
INTERRUPT TIMING								
t _{WINS}	R/W to INTERRUPT Set Time		15		25		25	ns
t _{EINS}	CE to INTERRUPT Set Time		15		25		25	ns
t _{INS}	Address to INTERRUPT Set Time		15		25		25	ns
t _{OINR}	OE to INTERRUPT Reset Time ^[16]		15		25		25	ns
t _{EINR}	CE to INTERRUPT Reset Time ^[16]		15		25		25	ns
t _{INR}	Address to INTERRUPT Reset Time ^[16]		15		25		25	ns

Notes:

- 16. These parameters are measured from the input signal changing, until the output pin goes to a high-impedance state.
- 17. CY7C140/CY7C141 only.
- 18. A write operation on Port A, where Port A has priority, leaves the data on Port B's outputs undisturbed until one access time after one of the following:
 BUSY on Port B goes HIGH.
 Port B's address is toggled.
 CE for Port B is toggled.
 R/W for Port B is toggled during valid read.

Switching Characteristics Over the Operating Range^[6,11]

Parameter	Description	7C130-35 7C131-35 7C140-35 7C141-35		7C130-45 7C131-45 7C140-45 7C141-45		7C130-55 7C131-55 7C140-55 7C141-55		Unit
		Min.	Max.	Min.	Max.	Min.	Max.	
READ CYCLE								
t _{RC}	Read Cycle Time	35		45		55		ns
t _{AA}	Address to Data Valid ^[12]		35		45		55	ns
t _{OHA}	Data Hold from Address Change	0		0		0		ns
t _{ACE}	CE LOW to Data Valid ^[12]		35		45		55	ns
t _{DOE}	OE LOW to Data Valid ^[12]		20		25		25	ns
t _{LZOE}	OE LOW to Low Z ^[9,13, 14]	3		3		3		ns
t _{HZOE}	OE HIGH to High Z ^[9,13, 14]		20		20		25	ns
t _{LZCE}	CE LOW to Low Z ^[9,13, 14]	5		5		5		ns
t _{HZCE}	CE HIGH to High Z ^[9,13, 14]		20		20		25	ns
t _{PU}	CE LOW to Power-Up ^[9]	0		0		0		ns
t _{PD}	CE HIGH to Power-Down ^[9]		35		35		35	ns

Switching Characteristics Over the Operating Range^[6,11] (continued)

Parameter	Description	7C130-35 7C131-35 7C140-35 7C141-35		7C130-45 7C131-45 7C140-45 7C141-45		7C130-55 7C131-55 7C140-55 7C141-55		Unit
		Min.	Max.	Min.	Max.	Min.	Max.	
WRITE CYCLE^[15]								
t _{WC}	Write Cycle Time	35		45		55		ns
t _{SCE}	\overline{CE} LOW to Write End	30		35		40		ns
t _{AW}	Address Set-Up to Write End	30		35		40		ns
t _{HA}	Address Hold from Write End	2		2		2		ns
t _{SA}	Address Set-Up to Write Start	0		0		0		ns
t _{PWE}	R/ \overline{W} Pulse Width	25		30		30		ns
t _{SD}	Data Set-Up to Write End	15		20		20		ns
t _{HD}	Data Hold from Write End	0		0		0		ns
t _{HZWE}	R/ \overline{W} LOW to High Z ^[14]		20		20		25	ns
t _{LZWE}	R/ \overline{W} HIGH to Low Z ^[14]	0		0		0		ns
BUSY/INTERRUPT TIMING								
t _{BLA}	\overline{BUSY} LOW from Address Match		20		25		30	ns
t _{BHA}	\overline{BUSY} HIGH from Address Mismatch ^[16]		20		25		30	ns
t _{BLC}	\overline{BUSY} LOW from \overline{CE} LOW		20		25		30	ns
t _{BHC}	\overline{BUSY} HIGH from \overline{CE} HIGH ^[16]		20		25		30	ns
t _{PS}	Port Set Up for Priority	5		5		5		ns
t _{WB^[17]}	R/ \overline{W} LOW after \overline{BUSY} LOW	0		0		0		ns
t _{WH}	R/ \overline{W} HIGH after \overline{BUSY} HIGH	30		35		35		ns
t _{BDD}	\overline{BUSY} HIGH to Valid Data		35		45		45	ns
t _{DDD}	Write Data Valid to Read Data Valid		Note 18		Note 18		Note 18	ns
t _{WDD}	Write Pulse to Data Delay		Note 18		Note 18		Note 18	ns
INTERRUPT TIMING								
t _{WINS}	R/ \overline{W} to $\overline{INTERRUPT}$ Set Time		25		35		45	ns
t _{EINS}	\overline{CE} to $\overline{INTERRUPT}$ Set Time		25		35		45	ns
t _{INS}	Address to $\overline{INTERRUPT}$ Set Time		25		35		45	ns
t _{OINR}	\overline{OE} to $\overline{INTERRUPT}$ Reset Time ^[16]		25		35		45	ns
t _{EINR}	\overline{CE} to $\overline{INTERRUPT}$ Reset Time ^[16]		25		35		45	ns
t _{INR}	Address to $\overline{INTERRUPT}$ Reset Time ^[16]		25		35		45	ns

Switching Waveforms

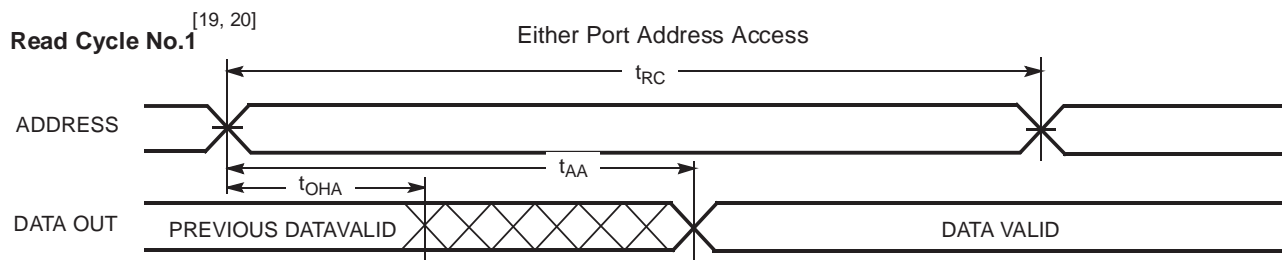

C130-7

Notes:

- 19. R/ \overline{W} is HIGH for read cycle.
- 20. Device is continuously selected, $\overline{CE} = V_{IL}$ and $\overline{OE} = V_{IL}$.

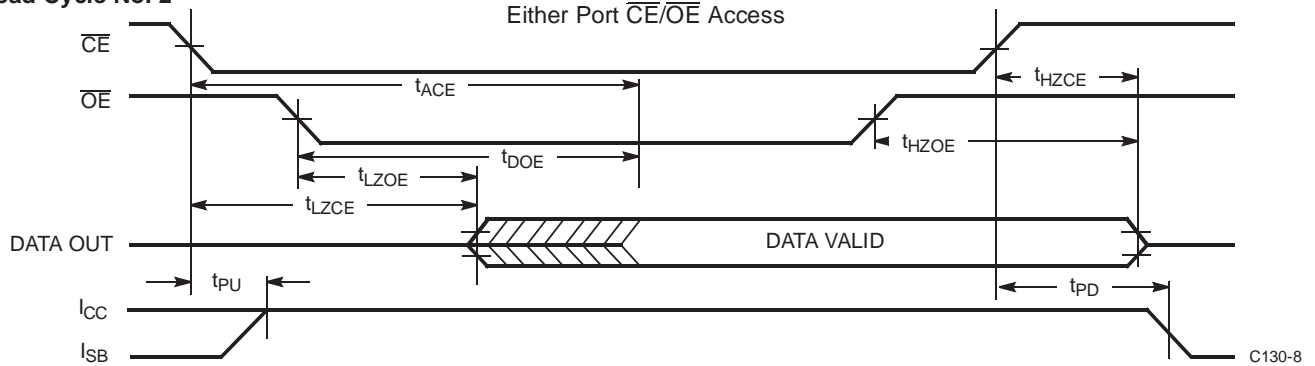
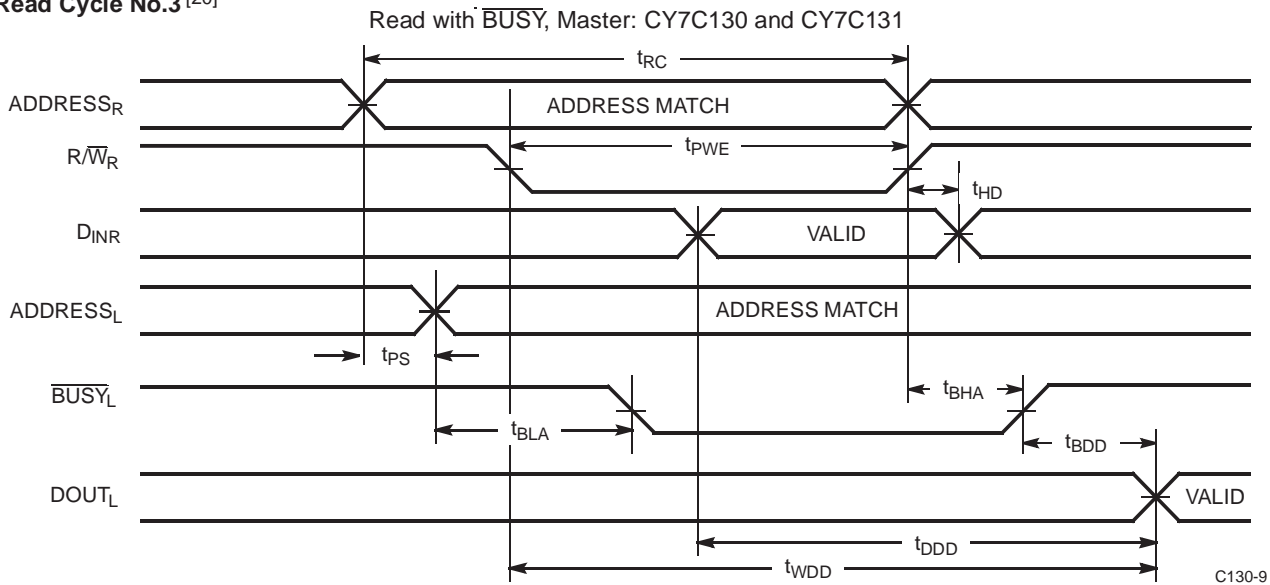
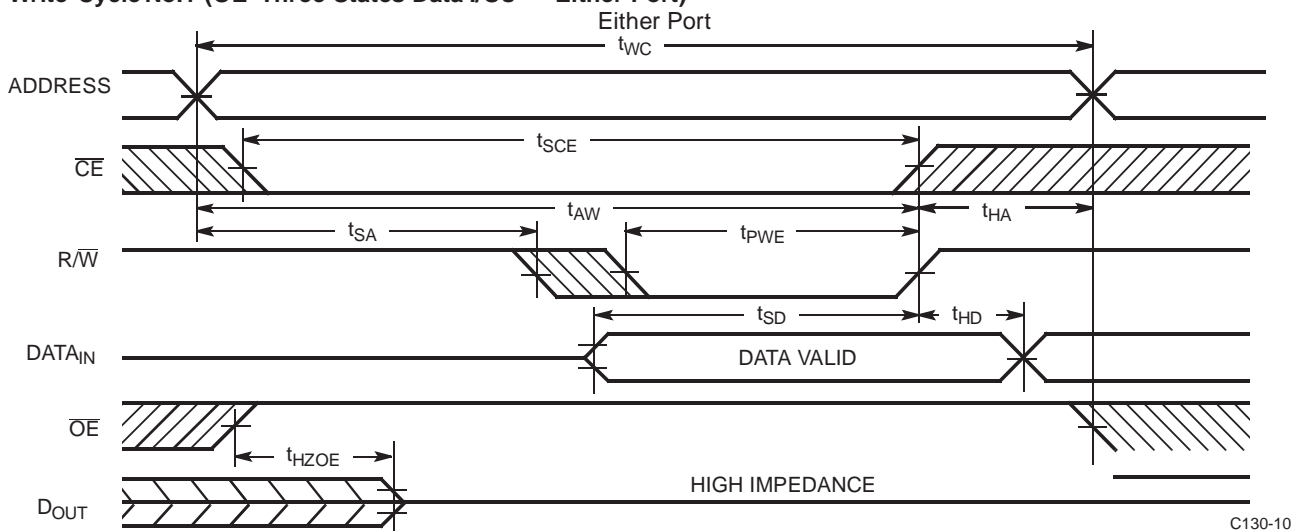
Switching Waveforms (continued)
Read Cycle No. 2 ^[19, 21]

Read Cycle No.3 ^[20]

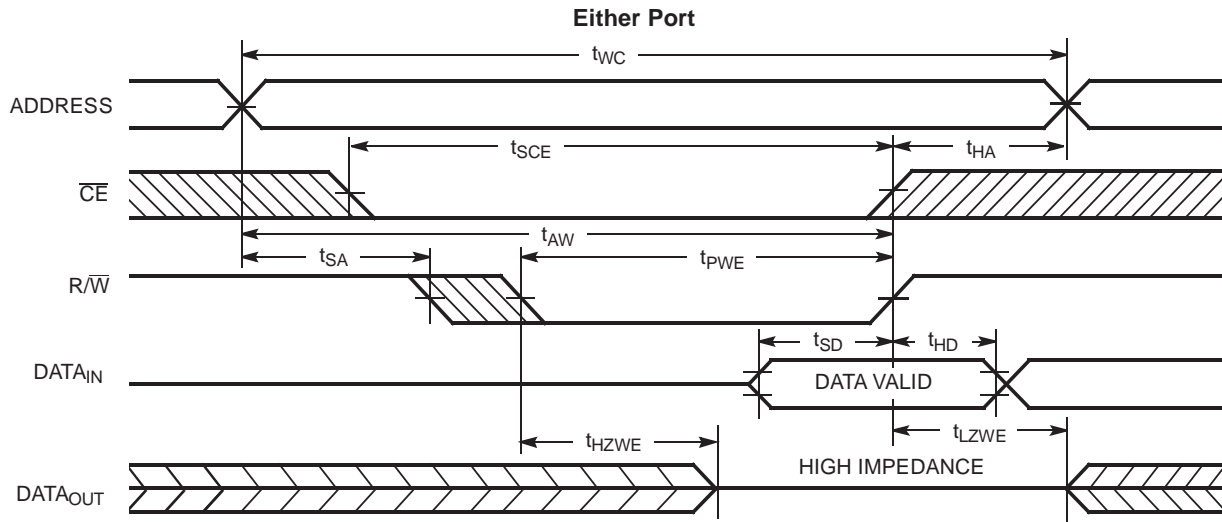
Write Cycle No.1 (OE Three-States Data I/Os - Either Port) ^[15, 22]

Notes:

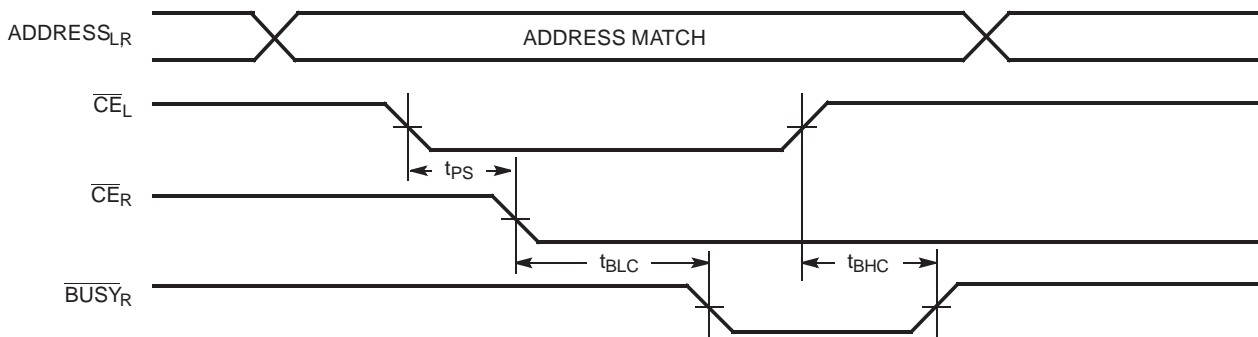
21. Address valid prior to or coincident with \overline{CE} transition LOW.
22. If \overline{OE} is LOW during a R/\overline{W} controlled write cycle, the write pulse width must be the larger of t_{PWE} or $t_{HZOE} + t_{SD}$ to allow the data I/O pins to enter high impedance and for data to be placed on the bus for the required t_{SD} .

Switching Waveforms (continued)
Write Cycle No. 2 (R/W Three-States Data I/Os - Either Port)^[16, 23]

C130-11

Busy Timing Diagram No. 1 (\overline{CE} Arbitration)
 \overline{CE}_L Valid First:

C130-12

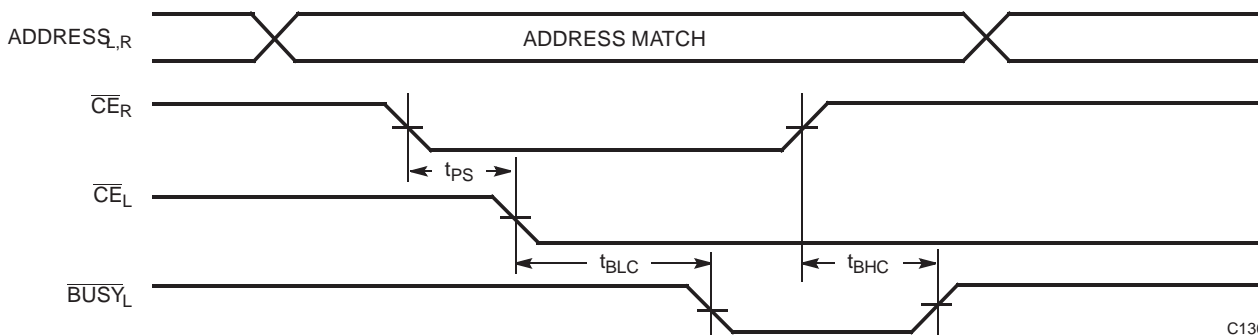
 \overline{CE}_R Valid First:

C130-13

Note:

 23. If the \overline{CE} LOW transition occurs simultaneously with or after the R/\overline{W} LOW transition, the outputs remain in the high-impedance state

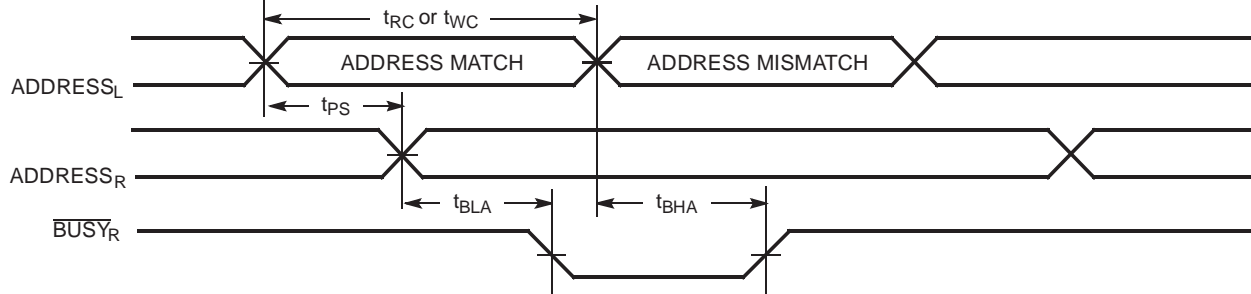
Switching Waveforms (continued)
Busy Timing Diagram No. 2 (Address Arbitration)
Left Address Valid First:

C130-14

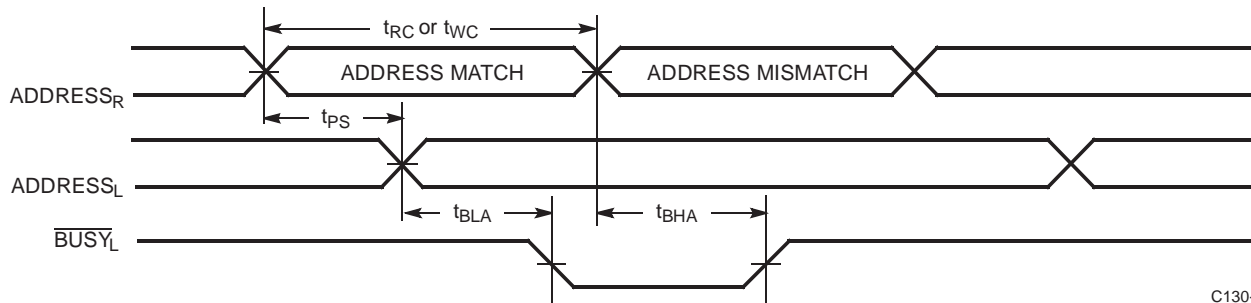
Right Address Valid First:

C130-15

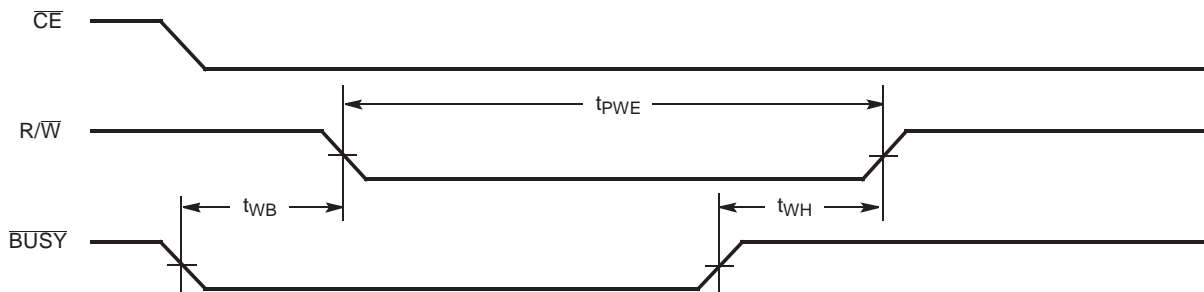
Busy Timing Diagram No. 3
Write with $\overline{\text{BUSY}}$ (Slave: CY7C140/CY7C141)

C130-16

Switching Waveforms (continued)

Interrupt Timing Diagrams

Left Side Sets $\overline{\text{INT}}_R$

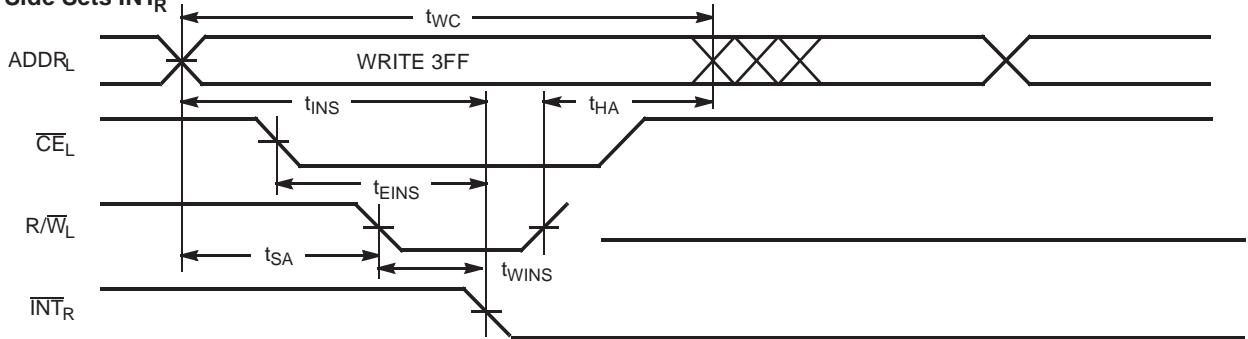

Right Side Clears $\overline{\text{INT}}_R$

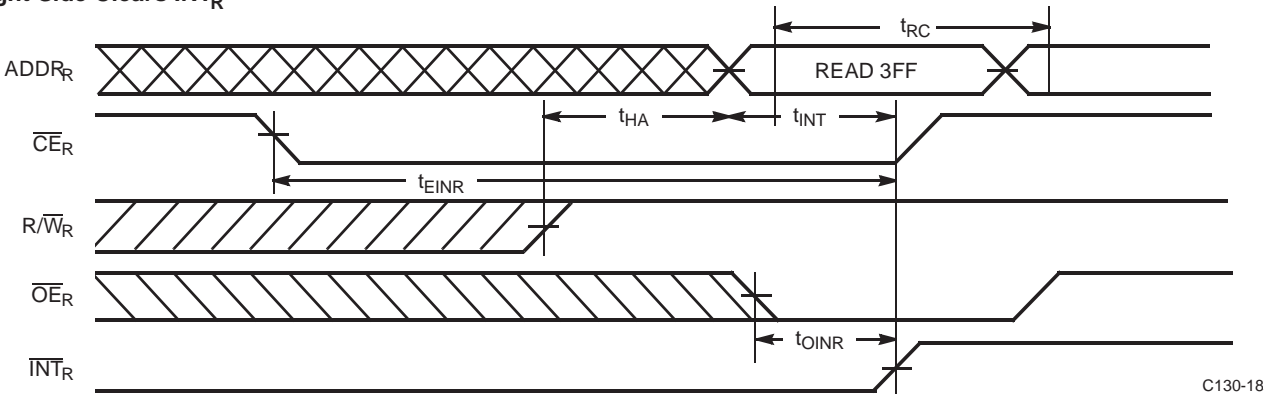

Right Side Sets $\overline{\text{INT}}_L$

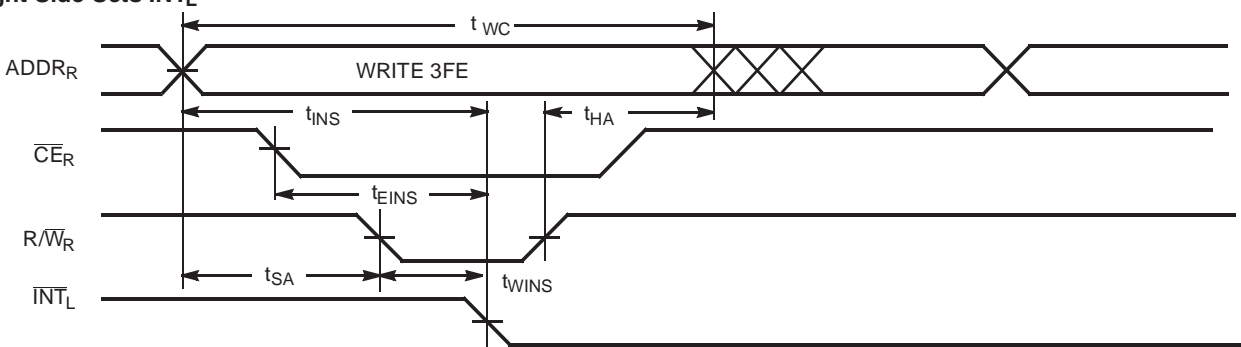

Left Side Clears $\overline{\text{INT}}_L$

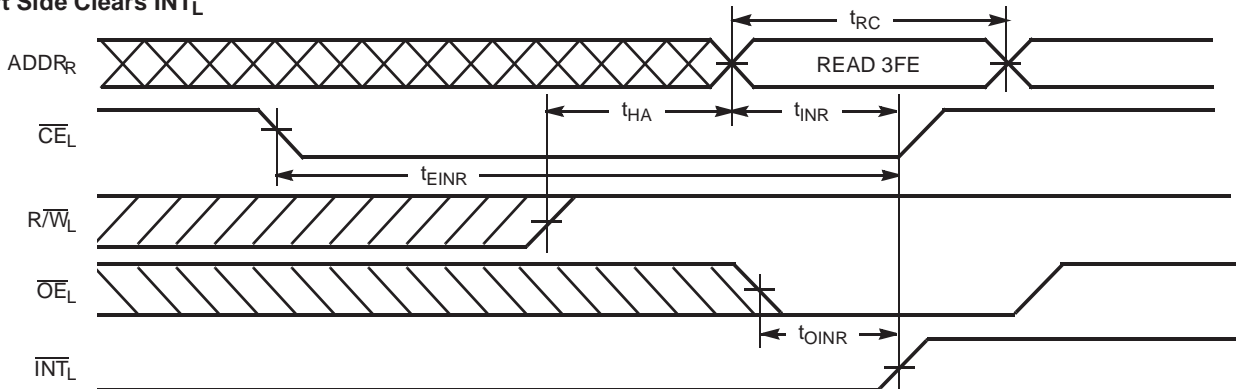

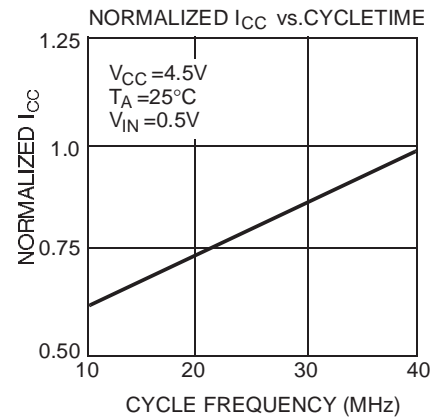
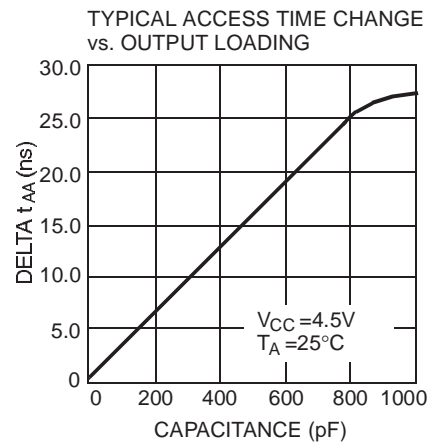
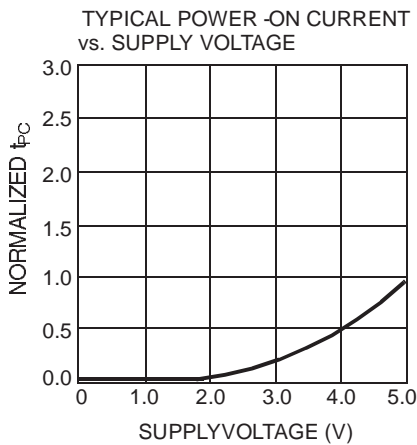
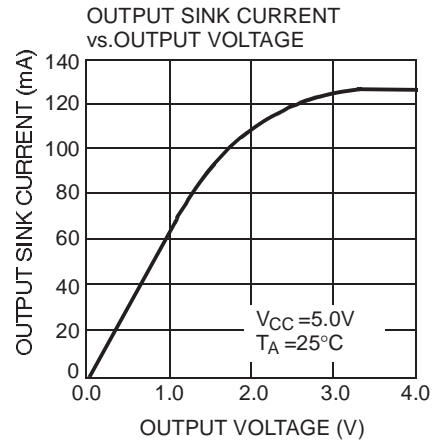
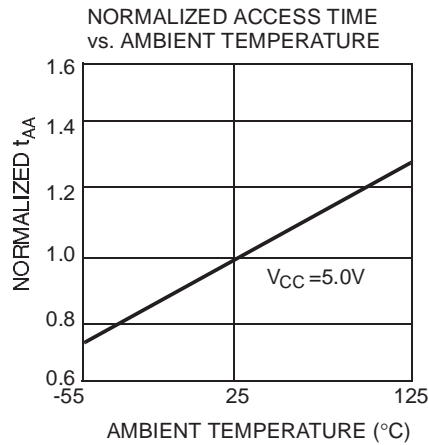
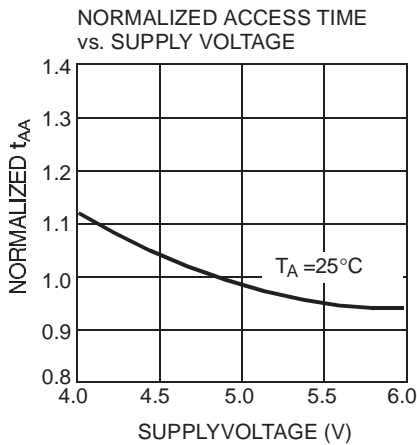
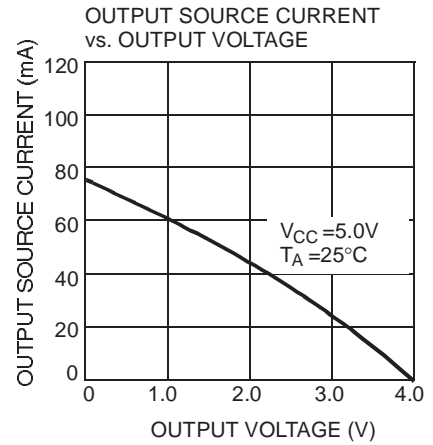
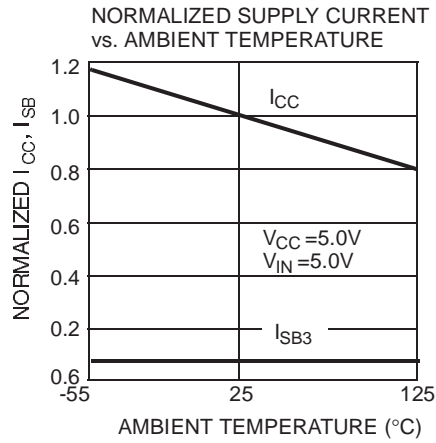
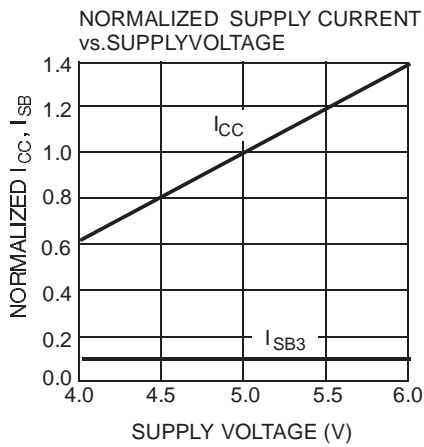
Typical DC and AC Characteristics

Ordering Information

Speed (ns)	Ordering Code	Package Name	Package Type	Operating Range
30	CY7C130-30PC	P25	48-Lead (600-Mil) Molded DIP	Commercial
	CY7C130-30PI	P25	48-Lead (600-Mil) Molded DIP	Industrial
35	CY7C130-35PC	P25	48-Lead (600-Mil) Molded DIP	Commercial
	CY7C130-35PI	P25	48-Lead (600-Mil) Molded DIP	Industrial
	CY7C130-35DMB	D26	48-Lead (600-Mil) Sidebrazed DIP	Military
45	CY7C130-45PC	P25	48-Lead (600-Mil) Molded DIP	Commercial
	CY7C130-45PI	P25	48-Lead (600-Mil) Molded DIP	Industrial
	CY7C130-45DMB	D26	48-Lead (600-Mil) Sidebrazed DIP	Military
55	CY7C130-55PC	P25	48-Lead (600-Mil) Molded DIP	Commercial
	CY7C130-55PI	P25	48-Lead (600-Mil) Molded DIP	Industrial
	CY7C130-55DMB	D26	48-Lead (600-Mil) Sidebrazed DIP	Military

Speed (ns)	Ordering Code	Package Name	Package Type	Operating Range
15	CY7C131-15JC	J69	52-Lead Plastic Leaded Chip Carrier	Commercial
	CY7C131-15NC	N52	52-Pin Plastic Quad Flatpack	
25	CY7C131-25JC	J69	52-Lead Plastic Leaded Chip Carrier	Commercial
	CY7C131-25NC	N52	52-Pin Plastic Quad Flatpack	
	CY7C131-25JI	J69	52-Lead Plastic Leaded Chip Carrier	Industrial
	CY7C131-25NI	N52	52-Pin Plastic Quad Flatpack	
30	CY7C131-30JC	J69	52-Lead Plastic Leaded Chip Carrier	Commercial
	CY7C131-30NC	N52	52-Pin Plastic Quad Flatpack	
	CY7C131-30JI	J69	52-Lead Plastic Leaded Chip Carrier	Industrial
35	CY7C131-35JC	J69	52-Lead Plastic Leaded Chip Carrier	Commercial
	CY7C131-35NC	N52	52-Pin Plastic Quad Flatpack	
	CY7C131-35JI	J69	52-Lead Plastic Leaded Chip Carrier	Industrial
	CY7C131-35NI	N52	52-Pin Plastic Quad Flatpack	
45	CY7C131-45JC	J69	52-Lead Plastic Leaded Chip Carrier	Commercial
	CY7C131-45NC	N52	52-Pin Plastic Quad Flatpack	
	CY7C131-45JI	J69	52-Lead Plastic Leaded Chip Carrier	Industrial
	CY7C131-45NI	N52	52-Pin Plastic Quad Flatpack	
55	CY7C131-55JC	J69	52-Lead Plastic Leaded Chip Carrier	Commercial
	CY7C131-55NC	N52	52-Pin Plastic Quad Flatpack	
	CY7C131-55JI	J69	52-Lead Plastic Leaded Chip Carrier	Industrial
	CY7C131-55NI	N52	52-Pin Plastic Quad Flatpack	

Shaded area contains preliminary information.



Ordering Information (continued)

Speed (ns)	Ordering Code	Package Name	Package Type	Operating Range
30	CY7C140-30PC	P25	48-Lead (600-Mil) Molded DIP	Commercial
	CY7C140-30PI	P25	48-Lead (600-Mil) Molded DIP	Industrial
35	CY7C140-35PC	P25	48-Lead (600-Mil) Molded DIP	Commercial
	CY7C140-35PI	P25	48-Lead (600-Mil) Molded DIP	Industrial
	CY7C140-35DMB	D26	48-Lead (600-Mil) Sidebrazed DIP	Military
45	CY7C140-45PC	P25	48-Lead (600-Mil) Molded DIP	Commercial
	CY7C140-45PI	P25	48-Lead (600-Mil) Molded DIP	Industrial
	CY7C140-45DMB	D26	48-Lead (600-Mil) Sidebrazed DIP	Military
55	CY7C140-55PC	P25	48-Lead (600-Mil) Molded DIP	Commercial
	CY7C140-55PI	P25	48-Lead (600-Mil) Molded DIP	Industrial
	CY7C140-55DMB	D26	48-Lead (600-Mil) Sidebrazed DIP	Military

Speed (ns)	Ordering Code	Package Name	Package Type	Operating Range
15	CY7C141-15JC	J69	52-Lead Plastic Leaded Chip Carrier	Commercial
	CY7C141-15NC	N52	52-Pin Plastic Quad Flatpack	
25	CY7C141-25JC	J69	52-Lead Plastic Leaded Chip Carrier	Commercial
	CY7C141-25NC	N52	52-Pin Plastic Quad Flatpack	
	CY7C141-25JI	J69	52-Lead Plastic Leaded Chip Carrier	Industrial
	CY7C141-25NI	N52	52-Pin Plastic Quad Flatpack	
30	CY7C141-30JC	J69	52-Lead Plastic Leaded Chip Carrier	Commercial
	CY7C141-30NC	N52	52-Pin Plastic Quad Flatpack	Industrial
	CY7C141-30JI	J69	52-Lead Plastic Leaded Chip Carrier	
35	CY7C141-35JC	J69	52-Lead Plastic Leaded Chip Carrier	Commercial
	CY7C141-35NC	N52	52-Pin Plastic Quad Flatpack	Industrial
	CY7C141-35JI	J69	52-Lead Plastic Leaded Chip Carrier	
	CY7C141-35NI	N52	52-Pin Plastic Quad Flatpack	
45	CY7C141-45JC	J69	52-Lead Plastic Leaded Chip Carrier	Commercial
	CY7C141-45NC	N52	52-Pin Plastic Quad Flatpack	Industrial
	CY7C141-45JI	J69	52-Lead Plastic Leaded Chip Carrier	
	CY7C141-45NI	N52	52-Pin Plastic Quad Flatpack	
55	CY7C141-55JC	J69	52-Lead Plastic Leaded Chip Carrier	Commercial
	CY7C141-55NC	N52	52-Pin Plastic Quad Flatpack	Industrial
	CY7C141-55JI	J69	52-Lead Plastic Leaded Chip Carrier	
	CY7C141-55NI	N52	52-Pin Plastic Quad Flatpack	

Shaded area contains preliminary information.

MILITARY SPECIFICATIONS
Group A Subgroup Testing
DC Characteristics

Parameter	Subgroups
V_{OH}	1, 2, 3
V_{OL}	1, 2, 3
V_{IH}	1, 2, 3
V_{IL} Max.	1, 2, 3
I_{IX}	1, 2, 3
I_{OZ}	1, 2, 3
I_{CC}	1, 2, 3
I_{SB1}	1, 2, 3
I_{SB2}	1, 2, 3
I_{SB3}	1, 2, 3
I_{SB4}	1, 2, 3

Switching Characteristics

Parameter	Subgroups
READ CYCLE	
t_{RC}	7, 8, 9, 10, 11
t_{AA}	7, 8, 9, 10, 11
t_{ACE}	7, 8, 9, 10, 11
t_{DOE}	7, 8, 9, 10, 11
WRITE CYCLE	
t_{WC}	7, 8, 9, 10, 11
t_{SCE}	7, 8, 9, 10, 11
t_{AW}	7, 8, 9, 10, 11
t_{HA}	7, 8, 9, 10, 11
t_{SA}	7, 8, 9, 10, 11
t_{PWE}	7, 8, 9, 10, 11
t_{SD}	7, 8, 9, 10, 11
t_{HD}	7, 8, 9, 10, 11

Parameter	Subgroups
BUSY/INTERRUPT TIMING	
t_{BLA}	7, 8, 9, 10, 11
t_{BHA}	7, 8, 9, 10, 11
t_{BLC}	7, 8, 9, 10, 11
t_{BHC}	7, 8, 9, 10, 11
t_{PS}	7, 8, 9, 10, 11
t_{WINS}	7, 8, 9, 10, 11
t_{EINS}	7, 8, 9, 10, 11
t_{INS}	7, 8, 9, 10, 11
t_{OINR}	7, 8, 9, 10, 11
t_{EINR}	7, 8, 9, 10, 11
t_{INR}	7, 8, 9, 10, 11
BUSY TIMING	
$t_{WB}^{[24]}$	7, 8, 9, 10, 11
t_{WH}	7, 8, 9, 10, 11
t_{BDD}	7, 8, 9, 10, 11

Note:

24. CY7C140/CY7C141 only.

Document #: 38-00027-L

Package Diagrams

48-Lead (600-Mil) Sidebraze DIP D26

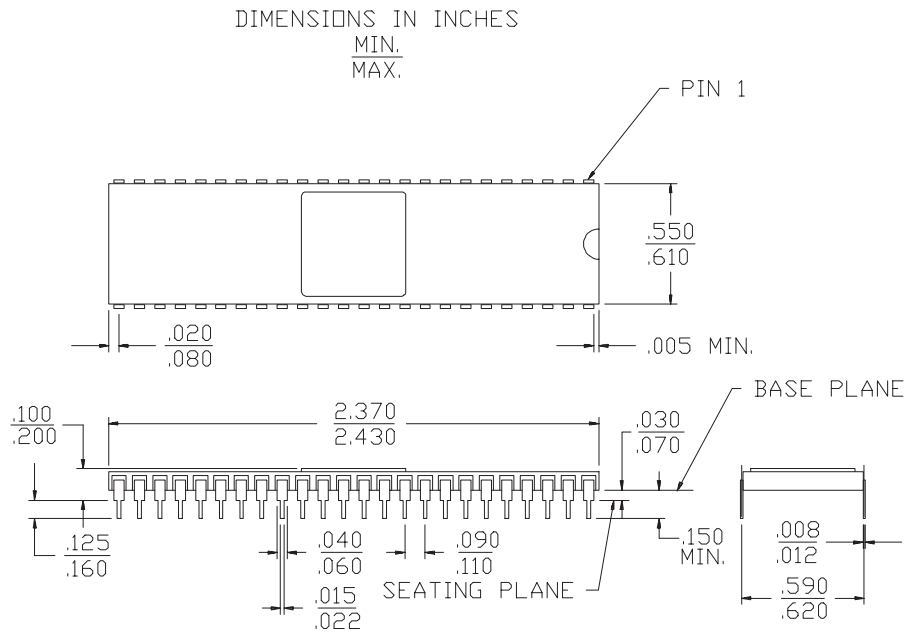

52-Lead Plastic Leaded Chip Carrier J69

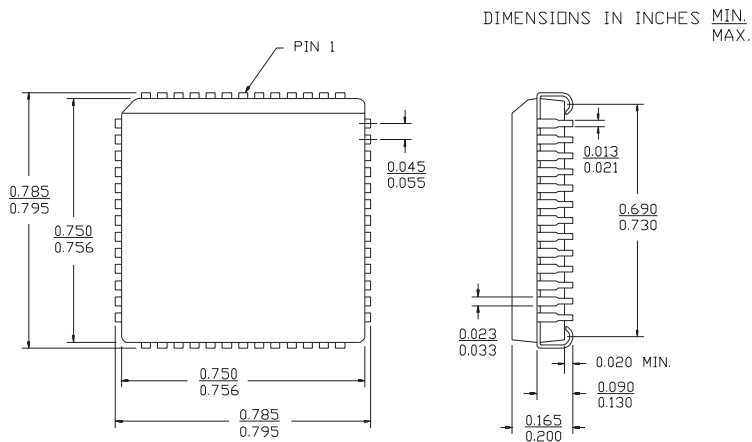

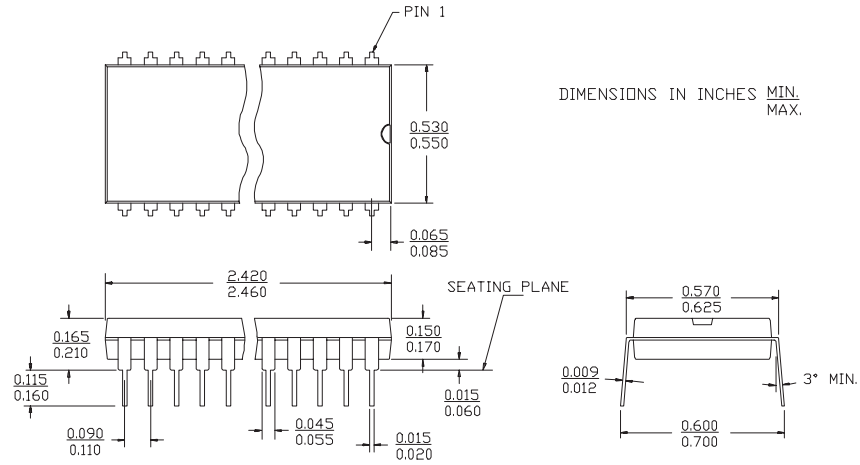
Package Diagrams (continued)
48-Lead (600-Mil) Molded DIP P25

This datasheet has been downloaded from:

www.DatasheetCatalog.com

Datasheets for electronic components.



LittleDiode supplies new, hard to find or obsolete electronic components and semiconductors all over the world.

With over two million different components listed you are sure to find the part you need.

Feel free to visit us today at our online store:

LittleDiode.com

Looking forward to providing you with the best possible service.