



CYPRESS

WirelessUSB™ LS 2.4-GHz DSSS Radio SoC

CYWUSB6932
CYWUSB6934

1.0 Features

- 2.4-GHz radio transceiver
- Operates in the unlicensed Industrial, Scientific, and Medical (ISM) band (2.4 GHz–2.483 GHz)
- -90-dBm receive sensitivity
- Up to 0 dBm output power
- Range of up to 10 meters or more
- Data throughput of up to 62.5 kbits/sec
- Highly integrated low cost, minimal number of external components required
- Dual DSSS reconfigurable baseband correlators
- SPI microcontroller interface (up to 2-MHz data rate)
- 13-MHz \pm 50-ppm input clock operation
- Low standby current < 1 μ A
- Integrated 30-bit Manufacturing ID
- Operating voltage from 2.7V to 3.6V
- Operating temperature from 0° to 70°C
- Offered in a small footprint 48 Quad Flat Pack No Leads (QFN)

2.0 Functional Description

The CYWUSB6932/CYWUSB6934 Integrated Circuits (ICs) are highly integrated 2.4-GHz Direct Sequence Spread Spectrum (DSSS) Radio System-on-Chip (SoC) ICs. From the Serial Peripheral Interface (SPI) to the antenna, these ICs are single-chip 2.4-GHz DSSS Gaussian Frequency Shift Keying (GFSK) baseband modems that connect directly to a microcontroller via simple serial interface.

The CYWUSB6932 transmit-only IC and the CYWUSB6934 transceiver IC are available in a small footprint 48-pin QFN package.

3.0 Applications

- PC Human Interface Devices (HIDs)
 - Mice
 - Keyboards
 - Joysticks
- Peripheral Gaming Devices
 - Game Controllers
 - Console Keyboards
- General
 - Presenter Tools
 - Remote Controls
 - Consumer Electronics
 - Barcode Scanners
 - POS Peripherals
 - Toys

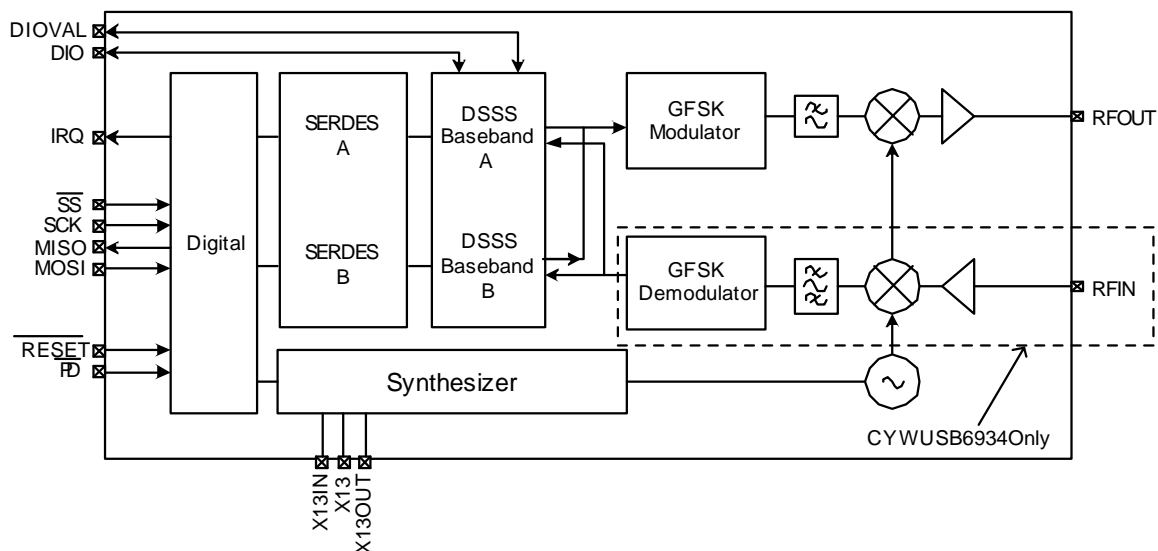

Figure 3-1. CYWUSB6932/CYWUSB6934 Simplified Block Diagram

3.1 Applications Support

The CYWUSB6932/CYWUSB6934 ICs are supported by the CY3632 WirelessUSB Development Kit. The development kit provides all of the materials and documents needed to cut the cord on wired applications including two radio modules that connect directly to two prototyping platform boards, comprehensive WirelessUSB protocol code examples a WirelessUSB Listener tool and all of the associated schematics, gerber files and bill of materials.

The CY4632 WirelessUSB LS Keyboard Mouse Reference Design provides a production-worthy example of a wireless mouse and keyboard system.

The CY3633 WirelessUSB LS Gaming Development Kit provides support for designing a wireless gamepad for the major gaming consoles and is offered as an accessory to the CY3632 WirelessUSB.

4.0 Functional Overview

The CYWUSB6932/CYWUSB6934 ICs provide a complete WirelessUSB LS SPI to antenna radio modem. The SoC is designed to implement wireless devices operating in the worldwide 2.4-GHz Industrial, Scientific, and Medical (ISM) frequency band (2.400 GHz–2.4835 GHz). It is intended for systems compliant with world-wide regulations covered by ETSI EN 301 489-1 V1.4.1, ETSI EN 300 328-1 V1.3.1 (European Countries); FCC CFR 47 Part 15 (USA and Industry Canada) and ARIB STD-T66 (Japan).

The CYWUSB6934 IC contains a 2.4-GHz radio transceiver, a GFSK modem and a dual DSSS reconfigurable baseband. The CYWUSB6932 IC contains a 2.4-GHz radio transmit-only, a GFSK modem and a DSSS baseband. The radio and baseband are both code- and frequency-agile. Forty-nine spreading codes selected for optimal performance (Gold codes) are supported across 78 1-MHz channels yielding a theoretical spectral capacity of 3822 channels. Both ICs support a range of up to 10 meters or more.

4.1 2.4-GHz Radio

The receiver and transmitter are a single-conversion low-Intermediate Frequency (low-IF) architecture with fully integrated IF channel matched filters to achieve high performance in the presence of interference. An integrated Power Amplifier (PA) provides an output power control range of 30 dB in seven steps.

Table 4-1. Internal PA Output Power Step Table

PA Setting	Typical Output Power (dBm)
7	0
6	-2.4
5	-5.6
4	-9.7
3	-16.4
2	-20.8
1	-24.8
0	-29.0

Both the receiver and transmitter integrated Voltage Controlled Oscillator (VCO) and synthesizer have the agility to cover the complete 2.4-GHz GFSK radio transmitter ISM band. The synthesizer provides the frequency-hopping local oscillator for the transmitter and receiver. The VCO loop filter is also integrated on-chip.

4.2 GFSK Modem

The transmitter uses a DSP-based vector modulator to convert the 1-MHz chips to an accurate GFSK carrier.

The receiver uses a fully integrated Frequency Modulator (FM) detector with automatic data slicer to demodulate the GFSK signal.

4.3 Dual DSSS Baseband

Data is converted to DSSS chips by a digital spreader. De-spreading is performed by an oversampled correlator. The DSSS baseband cancels spurious noise and assembles properly correlated data bytes.

The DSSS baseband has three operating modes: 64 chips/bit Single Channel, 32 chips/bit Single Channel, and 32 chips/bit Single Channel Dual Data Rate (DDR).

4.3.1 64 chips/bit Single Channel

The baseband supports a single data stream operating at 15.625 kbits/sec. The advantage of selecting this mode is its ability to tolerate a noisy environment. This is because the 15.625 kbits/sec data stream utilizes the longest PN Code resulting in the highest probability for recovering packets over the air. This mode can also be selected for systems requiring data transmissions over longer ranges.

4.3.2 32 chips/bit Single Channel

The baseband supports a single data stream operating at 31.25 kbits/sec.

4.3.3 32 chips/bit Single Channel Dual Data Rate (DDR)

The baseband spreads bits in pairs and supports a single data stream operating at 62.5 kbits/sec.

4.4 Serializer/Deserializer (SERDES)

The CYWUSB6934 IC has a data Serializer/Deserializer (SERDES), which provides byte-level framing of transmit and receive data. Bytes for transmission are loaded into the SERDES and receive bytes are read from the SERDES via the SPI interface. The SERDES provides double buffering of transmit and receive data. While one byte is being transmitted by the radio the next byte can be written to the SERDES data register insuring there are no breaks in transmitted data.

After a receive byte has been received it is loaded into the SERDES data register and can be read at any time until the next byte is received, at which time the old contents of the SERDES data register will be overwritten. The CYWUSB6932 IC only has a data Serializer.

4.5 Application Interfaces

Both ICs have a fully synchronous SPI slave interface for connectivity to the application MCU. Configuration and byte-oriented data transfer can be performed over this interface. An interrupt is provided to trigger real time events.

An optional SERDES Bypass mode (DIO) is provided for applications that require a synchronous serial bit-oriented data path. This interface is for data only.

4.6 Clocking and Power Management

A 13-MHz crystal (± 50 ppm or better) is directly connected to X13IN and X13 without the need for external capacitors. Both ICs have a programmable trim capability for adjusting the on-chip load capacitance supplied to the crystal. The Radio Frequency (RF) circuitry has on-chip decoupling capacitors. Both devices are powered from a 2.7V to 3.6V DC supply. Both devices can be shutdown to a fully static state using the PD pin.

Below are the requirements for the crystal to be directly connected to X13IN and X13:

- Nominal Frequency: 13 MHz
- Operating Mode: Fundamental Mode
- Resonance Mode: Parallel Resonant
- Frequency Stability: ± 50 ppm
- Series Resistance: ≤ 100 ohms
- Load Capacitance: 10 pF
- Drive Level: 10 μ W–100 μ W

4.7 Receive Signal Strength Indicator (RSSI)

The RSSI register (Reg 0x22) (applies only to the CYWUSB6934 IC) returns the relative signal strength of the ON-channel signal power and can be used to:

1. Determine the connection quality
2. Determine the value of the noise floor
3. Check for a quiet channel before transmitting.

The internal RSSI voltage is sampled through a 5-bit analog-to-digital converter (ADC). A state machine controls the conversion process. Under normal conditions, the RSSI state machine initiates a conversion when an ON-channel carrier is detected and remains above the noise floor for over 50 μ s. The conversion produces a 5-bit value in the RSSI register (Reg 0x22, bits 4:0) along with a valid bit, RSSI register (Reg 0x22, bit 5). The state machine then remains in HALT mode and does not reset for a new conversion until the receive mode is toggled off and on. Once a connection has been established, the RSSI register can be read to determine the relative connection quality of the channel. A RSSI register value lower than 10 indicates that the received signal strength is low, a value greater than 28 indicates a strong signal level.

To check for a quiet channel before transmitting, first set up receive mode properly and read the RSSI register (Reg 0x22). If the valid bit is zero, then force the Carrier Detect register

(Reg 0x2F, bit 7=1) to initiate an ADC conversion. Then, wait greater than 50 μ s and read the RSSI register again. Next, clear the Carrier Detect Register (Reg 0x2F, bit 7=0) and turn the receiver OFF. Measuring the noise floor of a quiet channel is inherently a 'noisy' process so, for best results, this procedure should be repeated several times (~20) to compute an average noise floor level. A RSSI register value of 0-10 indicates a channel that is relatively quiet. A RSSI register value greater than 10 indicates the channel is probably being used. A RSSI register value greater than 28 indicates the presence of a strong signal.

5.0 Application Interfaces

5.1 SPI Interface

The CYWUSB6932/CYWUSB6934 ICs have a four-wire SPI communication interface between an application MCU and one or more slave devices. The SPI interface supports single-byte and multi-byte serial transfers. The four-wire SPI communications interface consists of Master Out-Slave In (MOSI), Master In-Slave Out (MISO), Serial Clock (SCK), and Slave Select (SS).

The SPI receives SCK from an application MCU on the SCK pin. Data from the application MCU is shifted in on the MOSI pin. Data to the application MCU is shifted out on the MISO pin. The active-low Slave Select (SS) pin must be asserted to initiate a SPI transfer.

The application MCU can initiate a SPI data transfer via a multi-byte transaction. The first byte is the Command/Address byte, and the following bytes are the data bytes as shown in *Figure 5-1* through *Figure 5-4*. The SS signal should not be deasserted between bytes. The SPI communications is as follows:

- Command Direction (bit 7) = "0" Enables SPI read transaction. A "1" enables SPI write transactions.
- Command Increment (bit 6) = "1" Enables SPI auto address increment. When set, the address field automatically increments at the end of each data byte in a burst access, otherwise the same address is accessed.
- Six bits of address.
- Eight bits of data.

The SPI communications interface has a burst mechanism, where the command byte can be followed by as many data bytes as desired. A burst transaction is terminated by deasserting the slave select ($\overline{SS} = 1$). For burst read transactions, the application MCU must abide by the timing shown in *Figure 12-2*.

The SPI communications interface single read and burst read sequences are shown in *Figure 5-2* and *Figure 5-3*, respectively.

The SPI communications interface single write and burst write sequences are shown in *Figure 5-4* and *Figure 5-5*, respectively.

Bit #	Byte 1			Byte 1+N
	7	6	[5:0]	
Bit Name	DIR	INC	Address	
			Data	

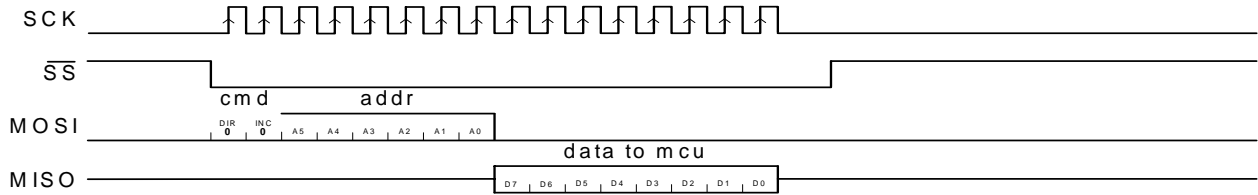
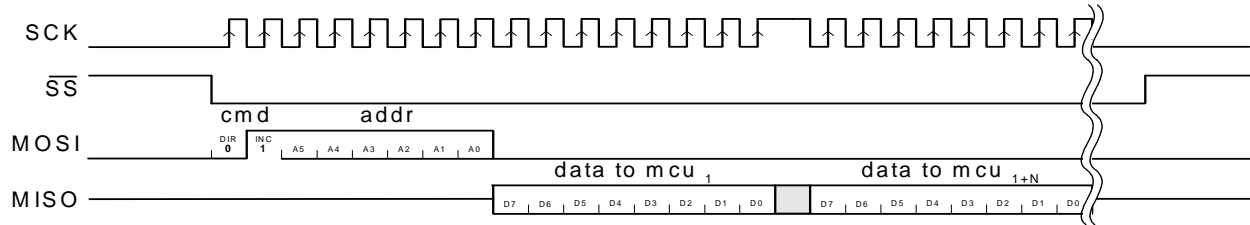
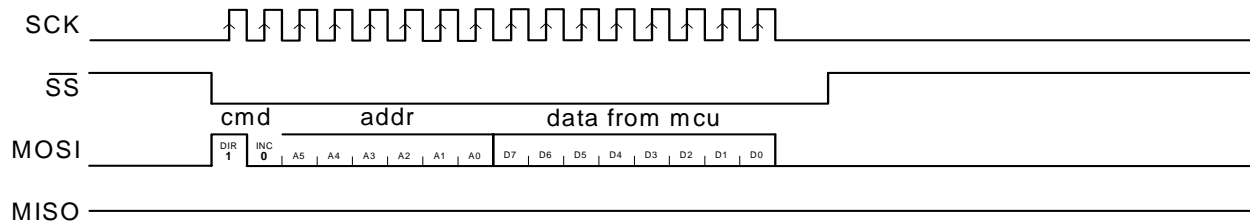
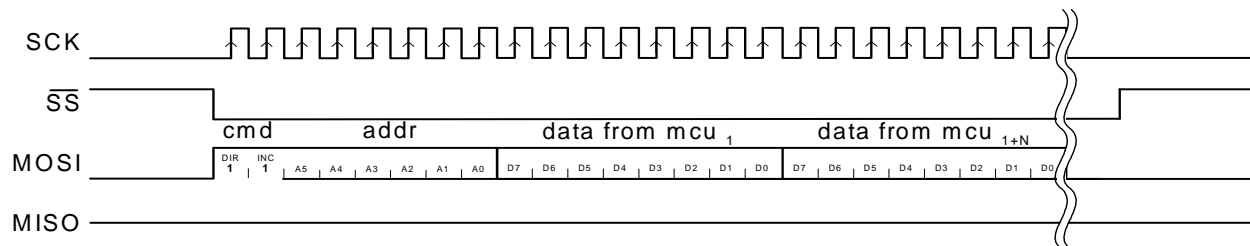
Figure 5-1. SPI Transaction Format

Figure 5-2. SPI Single Read Sequence

Figure 5-3. SPI Burst Read Sequence

Figure 5-4. SPI Single Write Sequence

Figure 5-5. SPI Burst Write Sequence

5.2 DIO Interface

The DIO communications interface is an optional SERDES bypass data-only transfer interface. In receive mode, DIO and DIOVAL are valid after the falling edge of IRQ, which clocks

the data as shown in *Figure 5-6*. In transmit mode, DIO and DIOVAL are sampled on the falling edge of the IRQ, which clocks the data as shown in *Figure 5-7*. The application MCU samples the DIO and DIOVAL on the rising edge of IRQ.

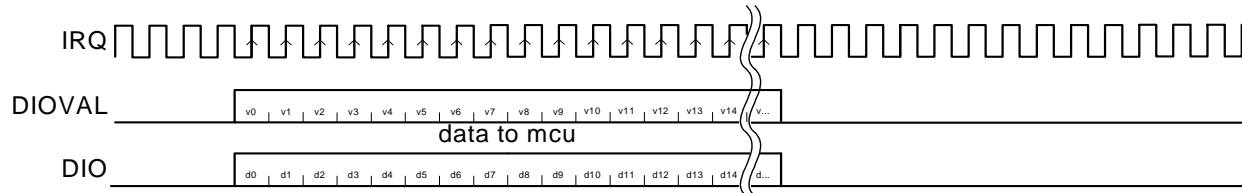

Figure 5-6. DIO Receive Sequence

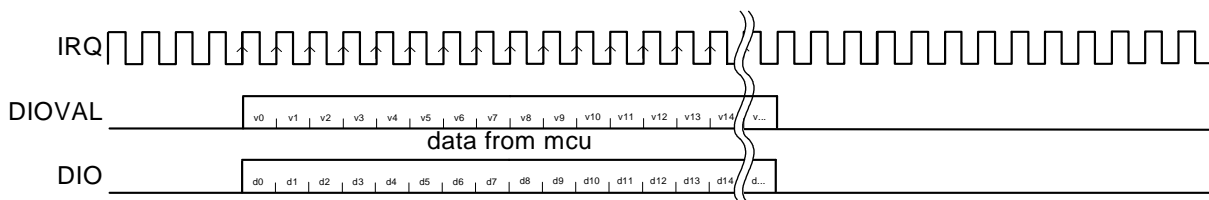

Figure 5-7. DIO Transmit Sequence

5.3 Interrupts

The CYWUSB6932/CYWUSB6934 ICs feature three sets of interrupts: transmit, receive (CYWUSB6934 only), and a wake interrupt. These interrupts all share a single pin (IRQ), but can be independently enabled/disabled. In transmit mode, all receive interrupts are automatically disabled, and in receive mode all transmit interrupts are automatically disabled. However, the contents of the enable registers are preserved when switching between transmit and receive modes.

Interrupts are enabled and the status read through 6 registers: Receive Interrupt Enable (Reg 0x07), Receive Interrupt Status (Reg 0x08), Transmit Interrupt Enable (Reg 0x0D), Transmit Interrupt Status (Reg 0x0E), Wake Enable (Reg 0x1C), Wake Status (Reg 0x1D).

If more than 1 interrupt is enabled at any time, it is necessary to read the relevant interrupt status register to determine which event caused the IRQ pin to assert. Even when a given interrupt source is disabled, the status of the condition that would otherwise cause an interrupt can be determined by reading the appropriate interrupt status register. It is therefore possible to use the devices without making use of the IRQ pin at all. Firmware can poll the interrupt status register(s) to wait for an event, rather than using the IRQ pin.

The polarity of all interrupts can be set by writing to the Configuration register (Reg 0x05), and it is possible to configure the IRQ pin to be open drain (if active low) or open source (if active high).

5.3.1 Wake Interrupt

When the \overline{PD} pin is low, the oscillator is stopped. After \overline{PD} is deasserted, the oscillator takes time to start, and until it has done so, it is not safe to use the SPI interface. The wake

interrupt indicates that the oscillator has started, and that the device is ready to receive SPI transfers.

The wake interrupt is enabled by setting bit 0 of the Wake Enable register (Reg 0x1C, bit 0=1). Whether or not a wake interrupt is pending is indicated by the state of bit 0 of the Wake Status register (Reg 0x1D, bit 0). Reading the Wake Status register (Reg 0x1D) clears the interrupt.

5.3.2 Transmit Interrupts

Four interrupts are provided to flag the occurrence of transmit events. The interrupts are enabled by writing to the Transmit Interrupt Enable register (Reg 0x0D), and their status may be determined by reading the Transmit Interrupt Status register (Reg 0x0E). If more than 1 interrupt is enabled, it is necessary to read the Transmit Interrupt Status register (Reg 0x0E) to determine which event caused the IRQ pin to assert.

The function and operation of these interrupts are described in detail in *Section 7.0*.

5.3.3 Receive Interrupts

Eight interrupts are provided to flag the occurrence of receive events, four each for SERDES A and B. In 64 chips/bit and 32 chips/bit DDR modes, only the SERDES A interrupts are available, and the SERDES B interrupts will never trigger, even if enabled. The interrupts are enabled by writing to the Receive Interrupt Enable register (Reg 0x07), and their status may be determined by reading the Receive Interrupt Status register (Reg 0x08). If more than one interrupt is enabled, it is necessary to read the Receive Interrupt Status register (Reg 0x08) to determine which event caused the IRQ pin to assert.

The function and operation of these interrupts are described in detail in *Section 7.0*.

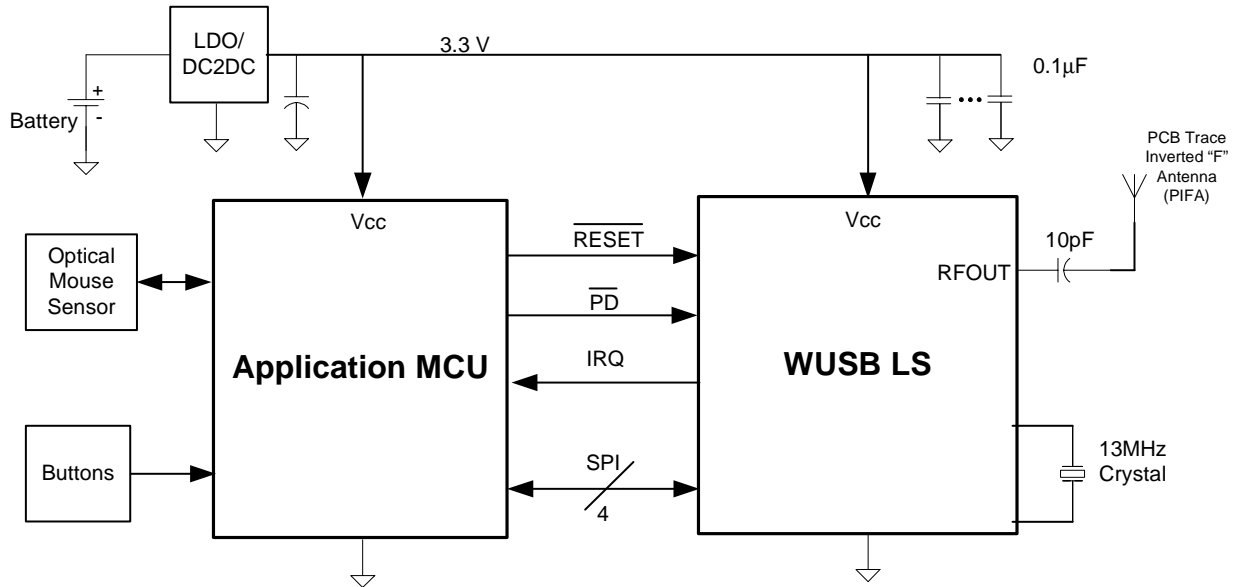
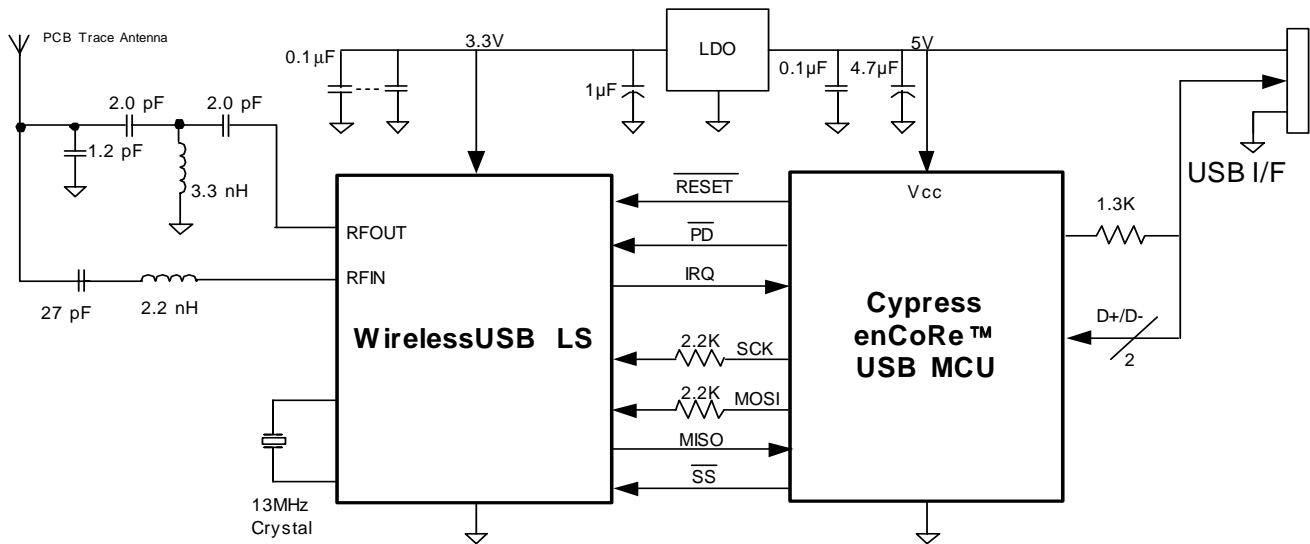
6.0 Application Examples

Figure 6-1. CYWUSB6932 Transmit-Only Battery-Powered Device

Figure 6-2. CYWUSB6934 USB Bridge Transceiver

7.0 Register Descriptions

Table 7-1 displays the list of registers inside the CYWUSB6932/CYWUSB6934 ICs that are addressable through the SPI interface. All registers are read and writable, except where noted.

Table 7-1. CYWUSB6932/CyWUSB6934 Register Map^[2]

Register Name	Mnemonic	CYWUSB6934 Address	Page	Default	Access
Revision ID	REG_ID	0x00	8	0x07	RO
Control	REG_CONTROL	0x03	8	0x00	RW
Data Rate	REG_DATA_RATE	0x04	9	0x00	RW
Configuration	REG_CONFIG	0x05	9	0x01	RW
SERDES Control	REG_SERDES_CTL	0x06	10	0x03	RW
Receive SERDES Interrupt Enable	REG_RX_INT_EN	0x07 ^[1]	11	0x00	RW
Receive SERDES Interrupt Status	REG_RX_INT_STAT	0x08 ^[1]	12	0x00	RO
Receive SERDES Data A	REG_RX_DATA_A	0x09 ^[1]	13	0x00	RO
Receive SERDES Valid A	REG_RX_VALID_A	0x0A ^[1]	13	0x00	RO
Receive SERDES Data B	REG_RX_DATA_B	0x0B ^[1]	13	0x00	RO
Receive SERDES Valid B	REG_RX_VALID_B	0x0C ^[1]	13	0x00	RO
Transmit SERDES Interrupt Enable	REG_TX_INT_EN	0x0D	14	0x00	RW
Transmit SERDES Interrupt Status	REG_TX_INT_STAT	0x0E	15	0x00	RO
Transmit SERDES Data	REG_TX_DATA	0x0F	16	0x00	RW
Transmit SERDES Valid	REG_TX_VALID	0x10	16	0x00	RW
PN Code	REG_PN_CODE	0x18–0x11	16	0x1E8B6A3DE0E9B222	RW
Threshold Low	REG_THRESHOLD_L	0x19 ^[1]	17	0x08	RW
Threshold High	REG_THRESHOLD_H	0x1A ^[1]	17	0x38	RW
Wake Enable	REG_WAKE_EN	0x1C	17	0x00	RW
Wake Status	REG_WAKE_STAT	0x1D	18	0x01	RO
Analog Control	REG_ANALOG_CTL	0x20	18	0x04	RW
Channel	REG_CHANNEL	0x21	19	0x00	RW
Receive Signal Strength Indicator	REG_RSSI	0x22 ^[1]	19	0x00	RO
PA Bias	REG_PA	0x23	19	0x00	RW
Crystal Adjust	REG_CRYSTAL_ADJ	0x24	20	0x00	RW
VCO Calibration	REG_VCO_CAL	0x26	20	0x00	RW
Reg Power Control	REG_PWR_CTL	0x2E	20	0x00	RW
Carrier Detect	REG_CARRIER_DETECT	0x2F	21	0x00	RW
Clock Manual	REG_CLOCK_MANUAL	0x32	21	0x00	RW
Clock Enable	REG_CLOCK_ENABLE	0x33	21	0x00	RW
Synthesizer Lock Count	REG_SYN_LOCK_CNT	0x38	21	0x64	RW
Manufacturing ID	REG_MID	0x3C–0x3F	21	–	RO

Notes:

1. Register not applicable to CYWUSB6932.
2. All registers are accessed Little Endian.

Figure 7-1. Revision ID Register

Addr: 0x00			REG_ID				Default: 0x07	
7	6	5	4	3	2	1	0	
Silicon ID				Product ID				

Bit	Name	Description
7:4	Silicon ID	These are the Silicon ID revision bits. 0000 = Rev A, 0001 = Rev B, etc. These bits are read-only.
3:0	Product ID	These are the Product ID revision bits. Fixed at value 0111. These bits are read-only.

Figure 7-2. Control

Addr: 0x03		REG_CONTROL				Default: 0x00	
7	6	5	4	3	2	1	0
RX Enable	TX Enable	PN Code Select	Bypass Internal Syn Lock Signal	Auto Internal PA Disable	Internal PA Enable	Reserved	Reserved

Bit	Name	Description
7	RX Enable	The Receive Enable bit is used to place the IC in receive mode. 1 = Receive Enabled 0 = Receive Disabled
6	TX Enable	The Transmit Enable bit is used to place the IC in transmit mode. 1 = Transmit Enabled 0 = Transmit Disabled
5	PN Code Select	The Pseudo-Noise Code Select bit selects between the upper or lower half of the 64 chips/bit PN code. 1 = 32 Most Significant Bits of PN code are used 0 = 32 Least Significant Bits of PN code are used This bit applies only when the Code Width bit is set to 32 chips/bit PN codes (Reg 0x04, bit 2=1).
4	Bypass Internal Syn Lock Signal	This bit controls whether the state machine waits for the internal Syn Lock Signal before waiting for the amount of time specified in the Syn Lock Count register (Reg 0x38), in units of 2 us. If the internal Syn Lock Signal is used then set Syn Lock Count to 25 to provide additional assurance that the synthesizer has settled. 1 = Bypass the Internal Syn Lock Signal and wait the amount of time in Syn Lock Count register (Reg 0x38) 0 = Wait for the Syn Lock Signal and then wait the amount of time specified in Syn Lock Count register (Reg 0x38) It is recommended that the application MCU sets this bit to 1 in order to guarantee a consistent settle time for the synthesizer.
3	Auto Internal PA Disable	The Auto Internal PA Disable bit is used to determine the method of controlling the Internal Power Amplifier. The two options are automatic control by the baseband or by firmware through register writes. For external PA usage, please see the description of the REG_ANALOG_CTL register (Reg 0x20). 1 = Register controlled Internal PA Enable 0 = Auto controlled Internal PA Enable When this bit is set to 1, the enabled state of the Internal PA is directly controlled by bit Internal PA Enable (Reg 0x03, bit 2). It is recommended that this bit is set to 0, leaving the PA control to the baseband.
2	Internal PA Enable	The Internal PA Enable bit is used to enable or disable the Internal Power Amplifier. 1 = Internal Power Amplifier Enabled 0 = Internal Power Amplifier Disabled This bit only applies when the Auto Internal PA Disable bit is selected (Reg 0x03, bit 3=1), otherwise this bit is don't care.
1	Reserved	This bit is reserved and should be written with a one.
0	Reserved	This bit is reserved and should be written with a zero.

Addr: 0x04			REG_DATA_RATE				Default: 0x00	
7	6	5	4	3	2	1	0	
Reserved					Code Width	Data Rate	Sample Rate	

Figure 7-3. Data Rate

Bit	Name	Description
7:3	Reserved	These bits are reserved and should be written with zeroes.
2 ^[3]	Code Width	<p>The Code Width bit is used to select between 32 chips/bit and 64 chips/bit PN codes.</p> <p>1 = 32 chips/bit PN codes 0 = 64 chips/bit PN codes</p> <p>The number of chips/bit used impacts a number of factors such as data throughput, range and robustness to interference. By choosing a 32 chips/bit PN-code, the data throughput can be doubled or even quadrupled (when double data rate is set). A 64 chips/bit PN code offers improved range over its 32 chips/bit counterpart as well as more robustness to interference. By selecting to use a 32 chips/bit PN code a number of other register bits are impacted and need to be addressed. These are PN Code Select (Reg 0x03, bit 5), Data Rate (Reg 0x04, bit 1), and Sample Rate (Reg 0x04, bit 0).</p>
1 ^[3]	Data Rate	<p>The Data Rate bit allows the user to select Double Data Rate mode of operation which delivers a raw data rate of 62.5kbits/sec.</p> <p>1 = Double Data Rate - 2 bits per PN code (No odd bit transmissions) 0 = Normal Data Rate - 1 bit per PN code</p> <p>This bit is applicable only when using 32 chips/bit PN codes which can be selected by setting the Code Width bit (Reg 0x04, bit 2=1). When using Double Data Rate, the raw data throughput is 62.5 kbits/sec because every 32 chips/bit PN code is interpreted as 2 bits of data. When using this mode a single 64 chips/bit PN code is placed in the PN code register. This 64 chips/bit PN code is then split into two and used by the baseband to offer the Double Data Rate capability. When using Normal Data Rate, the raw data throughput is 32kbits/sec. Additionally, Normal Data Rate enables the user to potentially correlate data using two differing 32 chips/bit PN codes.</p>
0 ^[3]	Sample Rate	<p>The Sample Rate bit allows the use of the 12x sampling when using 32 chips/bit PN codes and Normal Data Rate.</p> <p>1 = 12x Oversampling 0 = 6x Oversampling</p> <p>Using 12x oversampling improves the correlators receive sensitivity. When using 64 chips/bit PN codes or Double Data Rate this bit is don't care. The only time when 12x oversampling can be selected is when a 32 chips/bit PN code is being used with Normal Data Rate.</p>

Figure 7-4. Configuration

Addr: 0x05			REG_CONFIG				Default: 0x01	
7	6	5	4	3	2	1	0	
Reserved						IRQ Pin Select		

Bit	Name	Description
7:2	Reserved	These bits are reserved and should be written with zeroes.
1:0	IRQ Pin Select	<p>The Interrupt Request Pin Select bits are used to determine the drive method of the IRQ pin.</p> <p>11 = Open Source (IRQ asserted = 1, IRQ deasserted = Hi-Z) 10 = Open Drain (IRQ asserted = 0, IRQ deasserted = Hi-Z) 01 = CMOS (IRQ asserted = 1, IRQ deasserted = 0) 00 = CMOS Inverted (IRQasserted = 0, IRQ deasserted = 1)</p>

Note:

3. The following Reg 0x04, bits 2:0 values are not valid:
- 001 – Not Valid
 - 010 – Not Valid
 - 011 – Not Valid
 - 111 – Not Valid.

Addr: 0x06		REG_SERDES_CTL				Default: 0x03	
7	6	5	4	3	2	1	0
Reserved				SERDES Enable	EOF Length		

Figure 7-5. SERDES Control

Bit	Name	Description
7:4	Reserved	These bits are reserved and should be written with zeroes.
3	SERDES Enable	<p>The SERDES Enable bit is used to switch between bit-serial mode and SERDES mode.</p> <p>1 = SERDES enabled. 0 = SERDES disabled, bit-serial mode enabled.</p> <p>When the SERDES is enabled data can be written to and read from the IC one byte at a time, through the use of the SERDES Data registers. The bit-serial mode requires bits to be written one bit at a time through the use of the DIO/DIOVAL pins, refer to section 3.2. It is recommended that SERDES mode be used to avoid the need to manage the timing required by the bit-serial mode.</p>
2:0	EOF Length	<p>The End of Frame Length bits are used to set the number of sequential bit times for an inter-frame gap without valid data before an EOF event will be generated. When in receive mode and a valid bit has been received the EOF event can then be identified by the number of bit times that expire without correlating any new data. The EOF event causes data to be moved to the proper SERDES Data Register and can also be used to generate interrupts. If 0 is the EOF length, an EOF condition will occur at the first invalid bit after a valid reception.</p>

Addr: 0x07		REG_RX_INT_EN				Default: 0x00	
7	6	5	4	3	2	1	0
Underflow B	Overflow B	EOF B	Full B	Underflow A	Overflow A	EOF A	Full A

Figure 7-6. Receive SERDES Interrupt Enable

Bit	Name	Description
7	Underflow B	<p>The Underflow B bit is used to enable the interrupt associated with an underflow condition with the Receive SERDES Data B register (Reg 0x0B)</p> <p>1 = Underflow B interrupt enabled for Receive SERDES Data B 0 = Underflow B interrupt disabled for Receive SERDES Data B</p> <p>An underflow condition occurs when attempting to read the Receive SERDES Data B register (Reg 0x0B) when it is empty.</p>
6	Overflow B	<p>The Overflow B bit is used to enable the interrupt associated with an overflow condition with the Receive SERDES Data B register (Reg 0x0B)</p> <p>1 = Overflow B interrupt enabled for Receive SERDES Data B 0 = Overflow B interrupt disabled for Receive SERDES Data B</p> <p>An overflow condition occurs when new received data is written into the Receive SERDES Data B register (Reg 0x0B) before the prior data is read out.</p>
5	EOF B	<p>The End of Frame B bit is used to enable the interrupt associated with the Channel B Receiver EOF condition.</p> <p>1 = EOF B interrupt enabled for Channel B Receiver. 0 = EOF B interrupt disabled for Channel B Receiver.</p> <p>The EOF IRQ asserts during an End of Frame condition. End of Frame conditions occur after at least one bit has been detected, and then the number of invalid bits in the frame exceeds the number in the EOF length field. If 0 is the EOF length, and EOF condition will occur at the first invalid bit after a valid reception. This IRQ is cleared by reading the receive status register</p>
4	Full B	<p>The Full B bit is used to enable the interrupt associated with the Receive SERDES Data B register (Reg 0x0B) having data placed in it.</p> <p>1 = Full B interrupt enabled for Receive SERDES Data B 0 = Full B interrupt disabled for Receive SERDES Data B</p> <p>A Full B condition occurs when data is transferred from the Channel B Receiver into the Receive SERDES Data B register (Reg 0x0B). This could occur when a complete byte is received or when an EOF event occurs whether or not a complete byte has been received.</p>
3	Underflow A	<p>The Underflow A bit is used to enable the interrupt associated with an underflow condition with the Receive SERDES Data A register (Reg 0x09)</p> <p>1 = Underflow A interrupt enabled for Receive SERDES Data A 0 = Underflow A interrupt disabled for Receive SERDES Data A</p> <p>An underflow condition occurs when attempting to read the Receive SERDES Data A register (Reg 0x09) when it is empty.</p>
2	Overflow A	<p>The Overflow A bit is used to enable the interrupt associated with an overflow condition with the Receive SERDES Data A register (0x09)</p> <p>1 = Overflow A interrupt enabled for Receive SERDES Data A 0 = Overflow A interrupt disabled for Receive SERDES Data A</p> <p>An overflow condition occurs when new receive data is written into the Receive SERDES Data A register (Reg 0x09) before the prior data is read out.</p>
1	EOF A	<p>The End of Frame A bit is used to enable the interrupt associated with an End of Frame condition with the Channel A Receiver.</p> <p>1 = EOF A interrupt enabled for Channel A Receiver. 0 = EOF A interrupt disabled for Channel A Receiver.</p> <p>The EOF IRQ asserts during an End of Frame condition. End of Frame conditions occur after at least one bit has been detected, and then the number of invalid bits in a frame exceeds the number in the EOF length field. If 0 is the EOF length, an EOF condition will occur at the first invalid bit after a valid reception. This IRQ is cleared by reading the receive status register.</p>
0	Full A	<p>The Full A bit is used to enable the interrupt associated with the Receive SERDES Data A register (0x09) having data written into it.</p> <p>1 = Full A interrupt enabled for Receive SERDES Data A 0 = Full A interrupt disabled for Receive SERDES Data A</p> <p>A Full A condition occurs when data is transferred from the Channel A Receiver into the Receive SERDES Data A register (Reg 0x09). This could occur when a complete byte is received or when an EOF event occurs whether or not a complete byte has been received.</p>

Addr: 0x08		REG_RX_INT_STAT				Default: 0x00	
7	6	5	4	3	2	1	0
Valid B	Flow Violation B	EOF B	Full B	Valid A	Flow Violation A	EOF A	Full A

Figure 7-7. Receive SERDES Interrupt Status^[4]

Bit	Name	Description
7	Valid B	<p>The Valid B bit is true when all the bits in the Receive SERDES Data B register (Reg 0x0B) are valid.</p> <p>1 = All bits are valid for Receive SERDES Data B. 0 = Not all bits are valid for Receive SERDES Data B.</p> <p>When data is written into the Receive SERDES Data B register (Reg 0x0B) this bit is set if all of the bits within the byte that has been written are valid. This bit cannot generate an interrupt.</p>
6	Flow Violation B	<p>The Flow Violation B bit is used to signal whether an overflow or underflow condition has occurred for the Receive SERDES Data B register (Reg 0x0B).</p> <p>1 = Overflow/underflow interrupt pending for Receive SERDES Data B. 0 = No overflow/underflow interrupt pending for Receive SERDES Data B.</p> <p>Overflow conditions occur when the radio loads new data into the Receive SERDES Data B register (Reg 0x0B) before the prior data has been read. Underflow conditions occur when trying to read the Receive SERDES Data B register (Reg 0x0B) when the register is empty. This bit is cleared by reading the Receive Interrupt Status register (Reg 0x08)</p>
5	EOF B	<p>The End of Frame B bit is used to signal whether an EOF event has occurred on the Channel B receive.</p> <p>1 = EOF interrupt pending for Channel B. 0 = No EOF interrupt pending for Channel B.</p> <p>An EOF condition occurs for the Channel B Receiver when receive has begun and then the number of bit times specified in the SERDES Control register (Reg 0x06) elapse without any valid bits being received. This bit is cleared by reading the Receive Interrupt Status register (Reg 0x08)</p>
4	Full B	<p>The Full B bit is used to signal when the Receive SERDES Data B register (Reg 0x0B) is filled with data.</p> <p>1 = Receive SERDES Data B full interrupt pending. 0 = No Receive SERDES Data B full interrupt pending.</p> <p>A Full B condition occurs when data is transferred from the Channel B Receiver into the Receive SERDES Data B register (Reg 0x0B). This could occur when a complete byte is received or when an EOF event occurs whether or not a complete byte has been received.</p>
3	Valid A	<p>The Valid A bit is true when all of the bits in the Receive SERDES Data A Register (Reg 0x09) are valid.</p> <p>1 = All bits are valid for Receive SERDES Data A. 0 = Not all bits are valid for Receive SERDES Data A.</p> <p>When data is written into the Receive SERDES Data A register (Reg 0x09) this bit is set if all of the bits within the byte that has been written are valid. This bit cannot generate an interrupt.</p>
2	Flow Violation A	<p>The Flow Violation A bit is used to signal whether an overflow or underflow condition has occurred for the Receive SERDES Data A register (Reg 0x09).</p> <p>1 = Overflow/underflow interrupt pending for Receive SERDES Data A. 0 = No overflow/underflow interrupt pending for Receive SERDES Data A.</p> <p>Overflow conditions occur when the radio loads new data into the Receive SERDES Data A register (Reg 0x09) before the prior data has been read. Underflow conditions occur when trying to read the Receive SERDES Data A register (Reg 0x09) when the register is empty. This bit is cleared by reading the Receive Interrupt Status register (Reg 0x08)</p>
1	EOF A	<p>The End of Frame A bit is used to signal whether an EOF event has occurred on the Channel A receive.</p> <p>1 = EOF interrupt pending for Channel A. 0 = No EOF interrupt pending for Channel A.</p> <p>An EOF condition occurs for the Channel A Receiver when receive has begun and then the number of bit times specified in the SERDES Control register (0x06) elapse without any valid bits being received. This bit is cleared by reading the Receive Interrupt Status register (Reg 0x08).</p>
0	Full A	<p>The Full A bit is used to signal when the Receive SERDES Data A register (Reg 0x09) is filled with data.</p> <p>1 = Receive SERDES Data A full interrupt pending. 0 = No Receive SERDES Data A full interrupt pending.</p> <p>A Full A condition occurs when data is transferred from the Channel A Receiver into the Receive SERDES Data A Register (Reg 0x09). This could occur when a complete byte is received or when an EOF event occurs whether or not a complete byte has been received.</p>

Note:

- All status bits are set and readable in the registers regardless of IRQ enable status. This allows a polling scheme to be implemented without enabling IRQs. The status bits are affected by TX Enable and RX Enable (Reg 0x03, bits 7:6). For example, the receive status will read 0 if the IC is not in receive mode. These registers are read-only.

Addr: 0x09		REG_RX_DATA_A						Default: 0x00	
7	6	5	4	3	2	1	0		
Data									

Figure 7-8. Receive SERDES Data A
Bit Name Description

7:0 Data Received Data for Channel A. The over-the-air received order is bit 0 followed by bit 1, followed by bit 2, followed by bit 3, followed by bit 4, followed by bit 5, followed by bit 6, followed by bit 7. This register is read-only.

Addr: 0x0A		REG_RX_VALID_A						Default: 0x00	
7	6	5	4	3	2	1	0		
Valid									

Figure 7-9. Receive SERDES Valid A
Bit Name Description

7:0 Valid These bits indicate which of the bits in the Receive SERDES Data A register (Reg 0x09) are valid. A “1” indicates that the corresponding data bit is valid for Channel A.
 If the Valid Data bit is set in the Receive Interrupt Status register (Reg 0x08) all eight bits in the Receive SERDES Data A register (Reg 0x0A) are valid. Therefore, it is not necessary to read the Receive SERDES Valid A register (Reg 0x0C). This register is read-only.

Addr: 0x0B		REG_RX_DATA_B						Default: 0x00	
7	6	5	4	3	2	1	0		
Data									

Figure 7-10. Receive SERDES Data B
Bit Name Description

7:0 Data Received Data for Channel B. The over-the-air received order is bit 0 followed by bit 1, followed by bit 2, followed by bit 3, followed by bit 4, followed by bit 5, followed by bit 6, followed by bit 7. This register is read-only.

Figure 7-11. Receive SERDES Valid B

Addr: 0x0C		REG_RX_VALID_B						Default: 0x00	
7	6	5	4	3	2	1	0		
Valid									

Bit Name Description

7:0 Valid These bits indicate which of the bits in the Receive SERDES Data B register (Reg 0x0B) are valid. A “1” indicates that the corresponding data bit is valid for Channel B.
 If the Valid Data bit is set in the Receive Interrupt Status register (0x08) all eight bits in the Receive SERDES Data B register (Reg 0x0B) are valid. Therefore, it is not necessary to read the Receive SERDES Valid B register (Reg 0x0C). This register is read-only.

Addr: 0x0D		REG_TX_INT_EN				Default: 0x00	
7	6	5	4	3	2	1	0
Reserved				Underflow	Overflow	Done	Empty

Figure 7-12. Transmit SERDES Interrupt Enable

Bit	Name	Description
7:4	Reserved	These bits are reserved and should be written with zeroes.
3	Underflow	<p>The Underflow bit is used to enable the interrupt associated with an underflow condition associated with the Transmit SERDES Data register (Reg 0x0F)</p> <p>1 = Underflow interrupt enabled. 0 = Underflow interrupt disabled.</p> <p>An underflow condition occurs when attempting to transmit while the Transmit SERDES Data register (Reg 0x0F) does not have any data.</p>
2	Overflow	<p>The Overflow bit is used to enabled the interrupt associated with an overflow condition with the Transmit SERDES Data register (0x0F).</p> <p>1 = Overflow interrupt enabled. 0 = Overflow interrupt disabled.</p> <p>An overflow condition occurs when attempting to write new data to the Transmit SERDES Data register (Reg 0x0F) before the preceding data has been transferred to the transmit shift register.</p>
1	Done	<p>The Done bit is used to enable the interrupt that signals the end of the transmission of data.</p> <p>1 = Done interrupt enabled. 0 = Done interrupt disabled.</p> <p>The Done condition occurs when the Transmit SERDES Data register (Reg 0x0F) has transmitted all of its data and there is no more data for it to transmit.</p>
0	Empty	<p>The Empty bit is used to enable the interrupt that signals when the Transmit SERDES register (Reg 0x0F) is empty.</p> <p>1 = Empty interrupt enabled. 0 = Empty interrupt disabled.</p> <p>The Empty condition occurs when the Transmit SERDES Data register (Reg 0x0F) is loaded into the transmit buffer and it's safe to load the next byte</p>

Addr: 0x0E		REG_TX_INT_STAT				Default: 0x00	
7	6	5	4	3	2	1	0
Reserved				Underflow	Overflow	Done	Empty

Figure 7-13. Transmit SERDES Interrupt Status

Bit	Name	Description
7:4	Reserved	These bits are reserved. This register is read-only.
3	Underflow	<p>The Underflow bit is used to signal when an underflow condition associated with the Transmit SERDES Data register (Reg 0x0F) has occurred.</p> <p>1 = Underflow Interrupt pending. 0 = No Underflow Interrupt pending.</p> <p>This IRQ will assert during an underflow condition to the Transmit SERDES Data register (Reg 0x0F). An underflow occurs when the transmitter is ready to sample transmit data, but there is no data ready in the Transmit SERDES Data register (Reg 0x0F). This will only assert after the transmitter has transmitted at least one bit. This bit is cleared by reading the Transmit Interrupt Status register (Reg 0x0E).</p>
2	Overflow	<p>The Overflow bit is used to signal when an overflow condition associated with the Transmit SERDES Data register (0x0F) has occurred.</p> <p>1 = Overflow Interrupt pending. 0 = No Overflow Interrupt pending.</p> <p>This IRQ will assert during an overflow condition to the Transmit SERDES Data register (Reg 0x0F). An overflow occurs when the new data is loaded into the Transmit SERDES Data register (Reg 0x0F) before the previous data has been sent. This bit is cleared by reading the Transmit Interrupt Status register (Reg 0x0E).</p>
1	Done	<p>The Done bit is used to signal the end of a data transmission.</p> <p>1 = Done Interrupt pending. 0 = No Done Interrupt pending.</p> <p>This IRQ will assert when the data is finished sending a byte of data and there is no more data to be sent. This will only assert after the transmitter has transmitted as least one bit. This bit is cleared by reading the Transmit Interrupt Status register (Reg 0x0E).</p>
0	Empty	<p>The Empty bit is used to signal when the Transmit SERDES Data register (Reg 0x0F) has been emptied.</p> <p>1 = Empty Interrupt pending. 0 = No Empty Interrupt pending.</p> <p>This IRQ will assert when the transmit serdes is empty. When this IRQ is asserted it is ok to write to the Transmit SERDES Data register (Reg 0x0F). Writing the Transmit SERDES Data register (Reg 0x0F) will clear this IRQ. It will be set when the data is loaded into the transmitter, and it is ok to write new data.</p>

Note:

- All status bits are set and readable in the registers regardless of IRQ enable status. This allows a polling scheme to be implemented without enabling IRQs. The status bits are affected by the TX Enable and RX Enable (Reg 0x03, bits 7:6). For example, the transmit status will read 0 if the IC is not in transmit mode. These registers are read-only.

Addr: 0x19		REG_THRESHOLD_L				Default: 0x08	
7	6	5	4	3	2	1	0
Reserved		Threshold Low					

Figure 7-17. Threshold Low

Bit	Name	Description
7	Reserved	This bit is reserved and should be written with zero.
6:0	Threshold Low	The Threshold Low value is used to determine the number of missed chips allowed when attempting to correlate a single data bit of value '0'. A perfect reception of a data bit of '0' with a 64 chips/bit PN code would result in zero correlation matches, meaning the exact inverse of the PN code has been received. By setting the Threshold Low value to 0x08 for example, up to eight chips can be erroneous while still identifying the value of the received data bit. This value along with the Threshold High value determine the correlator count values for logic '1' and logic '0'. The threshold values used determine the sensitivity of the receiver to interference and the dependability of the received data. By allowing a minimal number of erroneous chips the dependability of the received data increases while the robustness to interference decreases. On the other hand increasing the maximum number of missed chips means reduced data integrity but increased robustness to interference and increased range.

Addr: 0x1A		REG_THRESHOLD_H				Default: 0x38	
7	6	5	4	3	2	1	0
Reserved		Threshold High					

Figure 7-18. Threshold High

Bit	Name	Description
7	Reserved	This bit is reserved and should be written with zero.
6:0	Threshold High	The Threshold High value is used to determine the number of matched chips allowed when attempting to correlate a single data bit of value '1'. A perfect reception of a data bit of '1' with a 64 chips/bit or a 32 chips/bit PN code would result in 64 chips/bit or 32 chips/bit correlation matches, respectively, meaning every bit was received perfectly. By setting the Threshold High value to 0x38 (64-8) for example, up to eight chips can be erroneous while still identifying the value of the received data bit. This value along with the Threshold Low value determine the correlator count values for logic '1' and logic '0'. The threshold values used determine the sensitivity of the receiver to interference and the dependability of the received data. By allowing a minimal number of erroneous chips the dependability of the received data increases while the robustness to interference decreases. On the other hand increasing the maximum number of missed chips means reduced data integrity but increased robustness to interference and increased range.

Addr: 0x1C		REG_WAKE_EN				Default: 0x00	
7	6	5	4	3	2	1	0
Reserved						Wakeup Enable	

Figure 7-19. Wake Enable

Bit	Name	Description
7:1	Reserved	These bits are reserved and should be written with zeroes.
0	Wakeup Enable	Wakeup interrupt enable. 0 = disabled 1 = enabled A wakeup event is triggered when the $\overline{\text{PD}}$ pin is deasserted and once the IC is ready to receive SPI communications.

Addr: 0x1D		REG_WAKE_STAT				Default: 0x01	
7	6	5	4	3	2	1	0
Reserved							Wakeup Status

Figure 7-20. Wake Status

Bit	Name	Description
7:1	Reserved	These bits are reserved. This register is read-only.
0	Wakeup Status	Wakeup status. 0 = Wake interrupt not pending 1 = Wake interrupt pending This IRQ will assert when a wakeup condition occurs. This bit is cleared by reading the Wake Status register (Reg 0x1D). This register is read-only.

Addr: 0x20		REG_ANALOG_CTL				Default: 0x00	
7	6	5	4	3	2	1	0
Reserved	Reg Write Control	MID Read Enable	Reserved	Reserved	PA Output Enable	PA Invert	Reset

Figure 7-21. Analog Control

Bit	Name	Description
7	Reserved	This bit is reserved and should be written with zero.
6	Reg Write Control	Enables write access to Reg 0x2E and Reg 0x2F. 1 = Enables write access to Reg 0x2E and Reg 0x2F 0 = Reg 0x2E and Reg 0x2F are read-only
5	MID Read Enable	The MID Read Enable bit must be set to read the contents of the Manufacturing ID register (Reg 0x3C-0x3F). Enabling the Manufacturing ID register (Reg 0x3C-0x3F) consumes power. This bit should only be set when reading the contents of the Manufacturing ID register (Reg 0x3C-0x3F). 1 = Enables read of MID registers 0 = Disables read of MID registers
4:3	Reserved	These bits are reserved and should be written with zeroes.
2	PA Output Enable	The Power Amplifier Output Enable bit is used to enable the PACTL pin for control of an external power amplifier. 1 = PA Control Output Enabled on PACTL pin 0 = PA Control Output Disabled on PACTL pin
1	PA Invert	The Power Amplifier Invert bit is used to specify the polarity of the PACTL signal when the PA Output Enable bit is set high. PA Output Enable and PA Invert cannot be simultaneously changed. 1 = PACTL active low 0 = PACTL active high
0	Reset	The Reset bit is used to generate a self-clearing device reset. 1 = Device Reset. All registers are restored to their default values. 0 = No Device Reset.

Addr: 0x21		REG_CHANNEL				Default: 0x00	
7	6	5	4	3	2	1	0
Reserved		Channel					

Figure 7-22. Channel

Bit	Name	Description
7	Reserved	This bit is reserved and should be written with zero.
6:0	Channel	<p>The Channel register (Reg 0x21) is used to determine the Synthesizer frequency. A value of 2 corresponds to a communication frequency of 2.402 GHz, while a value of 79 corresponds to a frequency of 2.479GHz. The channels are separated from each other by 1 MHz intervals.</p> <p>Limit application usage to channels 2-79 to adhere to FCC regulations. FCC regulations require that channels 0 and 1 and any channel greater than 79 be avoided. Use of other channels may be restricted by other regulatory agencies. The application MCU must ensure that this register is modified before transmitting data over the air for the first time.</p>

Addr: 0x22		REG_RSSI				Default: 0x00	
7	6	5	4	3	2	1	0
Reserved		Valid	RSSI				

Figure 7-23. Receive Signal Strength Indicator (RSSI)^[7]

Bit	Name	Description
7:6	Reserved	These bits are reserved. This register is read-only.
5	Valid	<p>The Valid bit indicates whether the RSSI value in bits [4:0] are valid. This register is Read Only.</p> <p>1 = RSSI value is valid 0 = RSSI value is invalid</p>
4:0	RSSI	The Receive Strength Signal Indicator (RSSI) value indicates the strength of the received signal. This is a read only value with the higher values indicating stronger received signals meaning more reliable transmissions.

Addr: 0x23		REG_PA				Default: 0x00	
7	6	5	4	3	2	1	0
Reserved					PA Bias		

Figure 7-24. PA Bias

Bit	Name	Description
7:3	Reserved	These bits are reserved and should be written with zeroes.
2:0	PA Bias	The Power Amplifier Bias (PA Bias) bits are used to set the transmit power of the IC through increasing (values up to 7) or decreasing (values down to 0) the gain of the on-chip Power Amplifier. The higher the register value the higher the transmit power. By changing the PA Bias value signal strength management functions can be accomplished. For general purpose communication a value of 7 is recommended.

Note:

- The RSSI will collect a single value each time the part is put into receive mode via Control register (Reg 0x03, bit 7=1). See Section 4.7 for more details.

Addr: 0x24		REG_CRYSTAL_ADJ				Default: 0x00	
7	6	5	4	3	2	1	0
Reserved	Clock Output Disable	Crystal Adjust					

Figure 7-25. Crystal Adjust

Bit	Name	Description
7	Reserved	This bit is reserved and should be written with zero.
6	Clock Output Disable	The Clock Output Disable bit disables the 13 MHz clock driven on the X13OUT pin. 1 = No 13 MHz clock driven externally. 0 = 13 MHz clock driven externally. If the 13 MHz clock is driven on the X13OUT pin then receive sensitivity will be reduced by -4 dBm on channels 5+13n. By default the 13 MHz clock output pin is enabled. This pin is useful for adjusting the 13 MHz clock, but it interfere with every 13th channel beginning with 2.405GHz channel. Therefore, it is recommended that the 13 MHz clock output pin be disabled when not in use.
5:0	Crystal Adjust	The Crystal Adjust value is used to calibrate the on-chip parallel load capacitance supplied to the crystal. Each increment of the Crystal Adjust value typically adds 0.135 pF of parallel load capacitance. The total range is 8.5 pF, starting at 8.65 pF. These numbers do not include PCB parasitics, which can add an additional 1-2 pF.

Addr: 0x26		REG_VCO_CAL				Default: 0x00	
7	6	5	4	3	2	1	0
VCO Slope Enable	Reserved						

Figure 7-26. VCO Calibration

Bit	Name	Description
7:6	VCO Slope Enable (Write-Only)	The Voltage Controlled Oscillator (VCO) Slope Enable bits are used to specify the amount of variance automatically added to the VCO. 11 = -5/+5 VCO adjust. The application MCU must configure this option during initialization. 10 = -2/+3 VCO adjust. 01 = Reserved. 00 = No VCO adjust. These bits are undefined for read operations.
5:0	Reserved	These bits are reserved and should be written with zeroes.

Addr: 0x2E		REG_PWR_CTL				Default: 0x00	
7	6	5	4	3	2	1	0
Reg Power Control	Reserved						

Figure 7-27. Reg Power Control

Bit	Name	Description
7	Reg Power Control	When set, this bit disables unused circuitry and saves radio power. The user must set Reg 0x20, bit 6=1 to enable writes to Reg 0x2E. The application MCU must set this bit during initialization.
6:0	Reserved	These bits are reserved and should be written with zeroes.

Addr: 0x2F		REG_CARRIER_DETECT						Default: 0x00	
7	6	5	4	3	2	1	0		
Carrier Detect Override		Reserved							

Figure 7-28. Carrier Detect

Bit	Name	Description
7	Carrier Detect Override	When set, this bit overrides carrier detect. The user must set Reg 0x20, bit 6=1 to enable writes to Reg 0x2F.
6:0	Reserved	These bits are reserved and should be written with zeroes.

Addr: 0x32		REG_CLOCK_MANUAL						Default: 0x00	
7	6	5	4	3	2	1	0		
Manual Clock Overrides									

Figure 7-29. Clock Manual

Bit	Name	Description
7:0	Manual Clock Overrides	This register must be written with 0x41 after reset for correct operation

Addr: 0x33		REG_CLOCK_ENABLE						Default: 0x00	
7	6	5	4	3	2	1	0		
Manual Clock Enables									

Figure 7-30. Clock Enable

Bit	Name	Description
7:0	Manual Clock Enables	This register must be written with 0x41 after reset for correct operation

Addr: 0x38		REG_SYN_LOCK_CNT						Default: 0x64	
7	6	5	4	3	2	1	0		
Count									

Figure 7-31. Synthesizer Lock Count

Bit	Name	Description
7:0	Count	Determines the length of delay in 2 μ s increments for the synthesizer to lock when auto synthesizer is enabled via Control register (0x03, bit 1=0) and not using the PLL lock signal. The default register setting is typically sufficient.

Addr: 0x3C-3F		REG_MID																															
31	30	29	28	27	26	25	24	23	22	21	20	19	18	17	16	15	14	13	12	11	10	9	8	7	6	5	4	3	2	1	0		
Address 0x3F								Address 0x3E								Address 0x3D								Address 0x3C									

Figure 7-32. Manufacturing ID

Bit	Name	Description
31:30	Address[31:30]	These bits are read back as zeroes.
29:0	Address[29:0]	These bits are the Manufacturing ID (MID) for each IC. The contents of these bits cannot be read unless the MID Read Enable bit (bit 5) is set in the Analog Control register (Reg 0x20). Enabling the Manufacturing ID register (Reg 0x3C-0x3F) consumes power. The MID Read Enable bit in the Analog Control register (Reg 0x20, bit 5) should only be set when reading the contents of the Manufacturing ID register (Reg 0x3C-0x3F). This register is read-only.

8.0 Pin Definitions

Table 8-1. Pin Description Table for the CYWUSB6932/CYWUSB6934

Pin QFN	Name	Type	Default	Description
46	RFIN	Input	Input	RF Input. Modulated RF signal received (CYWUSB6934 only).
5	RFOUT	Output	N/A	RF Output. Modulated RF signal to be transmitted.
38	X13	Input	N/A	Crystal Input. (refer to <i>Section 4.6</i>).
35	X13IN	Input	N/A	Crystal Input. (refer to <i>Section 4.6</i>).
26	X13OUT	Output/Hi-Z	Output	System Clock. Buffered 13-MHz system clock.
33	$\overline{\text{PD}}$	Input	N/A	Power Down. Asserting this input (low), will put the CYWUSB6932/CYWUSB6934 in the Suspend Mode (X13OUT is 0 when $\overline{\text{PD}}$ is Low).
14	$\overline{\text{RESET}}$	Input	N/A	Active LOW Reset. Device reset.
34	PACTL	I/O	Input	PACTL. External Power Amplifier control. Pull-down or make output.
20	DIO	I/O	Input	Data Input/Output. SERDES Bypass Mode Data Transmit/Receive.
19	DIOVAL	I/O	Input	Data I/O Valid. SERDES Bypass Mode Data Transmit/Receive Valid.
21	IRQ	Output /Hi-Z	Output	IRQ. Interrupt and SERDES Bypass Mode DIOCLK.
23	MOSI	Input	N/A	Master-Output-Slave-Input Data. SPI data input pin.
24	MISO	Output/Hi-Z	Hi-Z	Master-Input-Slave-Output Data. SPI data output pin.
25	SCK	Input	N/A	SPI Input Clock. SPI clock.
22	$\overline{\text{SS}}$	Input	N/A	Slave Select Enable. SPI enable.
6, 9, 16, 28, 29, 32, 41, 42, 44, 45	VCC	VCC	H	$V_{\text{CC}} = 2.7\text{V to }3.6\text{V}$.
13	GND	GND	L	Ground = 0V.
1, 2, 3, 4, 7, 8, 10, 11, 12, 15, 17, 18, 27, 30, 31, 36, 37, 39, 40, 43, 47, 48	NC	N/A	N/A	Must be tied to Ground.
Exposed Paddle	GND	GND	L	Must be tied to Ground.

CYWUSB6934/CYWUSB6932
Top View*

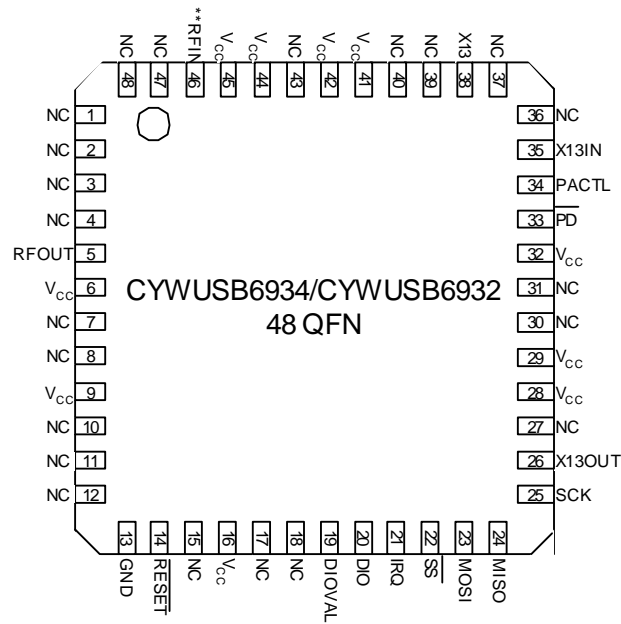

* E-PAD BOTTOMSIDE

** CYWUSB6934 Only

Figure 8-1. CYWUSB6934/CYWUSB6932, 48 QFN – Top View

9.0 Absolute Maximum Ratings

Storage Temperature	-65°C to +150°C
Ambient Temperature with Power Applied.....	-55°C to +125°C
Supply Voltage on V _{CC} relative to V _{SS}	-0.3V to +3.9V
DC Voltage to Logic Inputs ^[8]	-0.3V to V _{CC} +0.3V
DC Voltage applied to Outputs in High-Z State.....	-0.3V to V _{CC} +0.3V
Static Discharge Voltage (Digital) ^[9]	>2000V
Static Discharge Voltage (RF) ^[9]	500V
Latch-up Current.....	+200 mA, -200 mA

10.0 Operating Conditions

V _{CC} (Supply Voltage)	2.7V to 3.6V
T _A (Ambient Temperature Under Bias)	0°C to +70°C
Ground Voltage	0V
F _{OSC} (Oscillator or Crystal Frequency)	13 MHz ±50 ppm

11.0 DC Characteristics (over the operating range)

Table 11-1. DC Parameters

Parameter	Description	Conditions	Min.	Typ. ^[11]	Max.	Unit
V _{CC}	Supply Voltage		2.7	3.0	3.6	V
V _{OH1}	Output High Voltage condition 1	At I _{OH} = -100.0µA	V _{CC} -0.1	V _{CC}		V
V _{OH2}	Output High Voltage condition 2	At I _{OH} = -2.0 mA	2.4	3.0		V
V _{OL}	Output Low Voltage	At I _{OL} = 2.0 mA		0.0	0.4	V
V _{IH}	Input High Voltage		2.0		V _{CC} ^[10]	V
V _{IL}	Input Low Voltage		-0.3		0.8	V
I _{IL}	Input Leakage Current	0 < V _{IN} < V _{CC}	-1	0.26	+1	µA
C _{IN}	Pin Input Capacitance (except X13, X13IN, RFIN)			3.5	10	pF
I _{Sleep}	Current consumption during power-down mode	\overline{PD} = LOW		0.24	10	µA
IDLE I _{CC}	Current consumption without synthesizer	\overline{PD} = HIGH		3		mA
STARTUP I _{CC}	ICC from \overline{PD} high to oscillator stable.			1.8		mA
TX AVG I _{CC1}	Average transmitter current consumption ^[12]	no handshake		5.9		mA
TX AVG I _{CC2}	Average transmitter current consumption ^[13]	with handshaking		8.1		mA
RX I _{CC} (PEAK)	Current consumption during receive			57.7		mA
TX I _{CC} (PEAK)	Current consumption during transmit			69.1		mA
SYNTH SETTLE I _{CC}	Current consumption with Synthesizer on, No Transmit or Receive			28.7		mA

Notes:

8. It is permissible to connect voltages above V_{CC} to inputs through a series resistor limiting input current to 1 mA. This can't be done during power down mode. AC timing not guaranteed.
9. Human Body Model (HBM).
10. It is permissible to connect voltages above V_{CC} to inputs through a series resistor limiting input current to 1 mA.
11. Typ. values measured with V_{CC} = 3.0V @ 25°C
12. Average I_{CC} when transmitting a 5-byte packet (3 data bytes + 2 bytes of protocol) every 10ms using the WirelessUSB LS 1-way protocol.
13. Average I_{CC} when transmitting a 5-byte packet (3 data bytes + 2 bytes of protocol) every 10ms using the WirelessUSB LS 2-way protocol.

12.0 AC Characteristics ^[14]

Table 12-1. SPI Interface ^[16]

Parameter	Description	Min.	Typ.	Max.	Unit
t_{SCK_CYC}	SPI Clock Period	476			ns
t_{SCK_HI} (BURST READ) ^[15]	SPI Clock High Time	238			ns
t_{SCK_HI}	SPI Clock High Time	158			ns
t_{SCK_LO}	SPI Clock Low Time	158			ns
t_{DAT_SU}	SPI Input Data Set-up Time	10			ns
t_{DAT_HLD}	SPI Input Data Hold Time	97 ^[16]			ns
t_{DAT_VAL}	SPI Output Data Valid Time	77 ^[16]		174 ^[16]	ns
t_{SS_SU}	SPI Slave Select Set-up Time before first positive edge of SCK ^[17]	250			ns
t_{SS_HLD}	SPI Slave Select Hold Time after last negative edge of SCK	80			ns

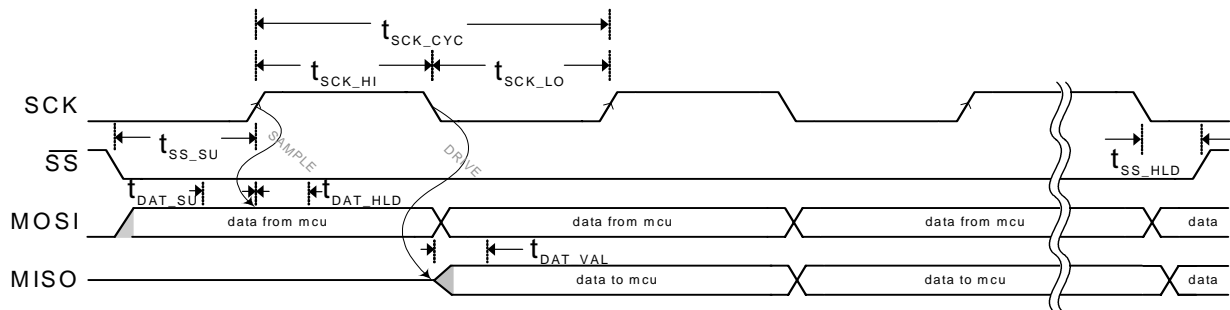
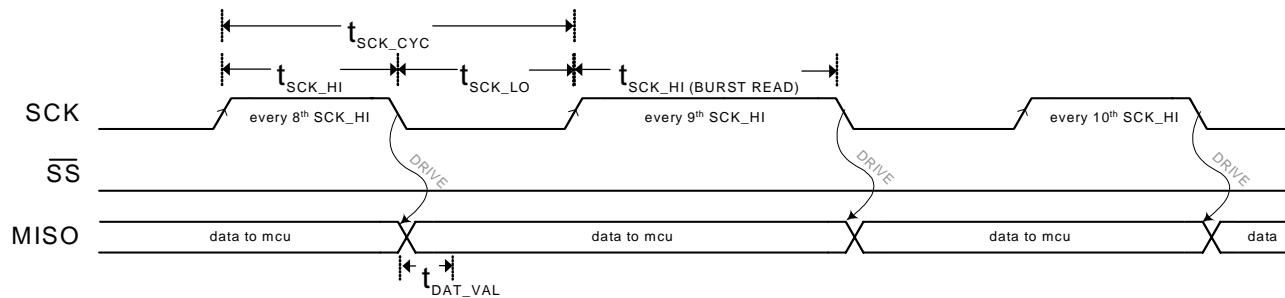
Figure 12-1. SPI Timing Diagram

Figure 12-2. SPI Burst Read Every 9th SCK HI Stretch Timing Diagram
Notes:

14. AC values are not guaranteed if voltages on any pin exceed V_{CC} .
15. This stretch only applies to every 9th SCK HI pulse for SPI Burst Reads only.
16. For $F_{OSC} = 13 \text{ MHz} \pm 50\text{ppm}$, 3.3v @ 25°C .
17. SCK must start low, otherwise the success of SPI transactions are not guaranteed.

Table 12-2. DIO Interface

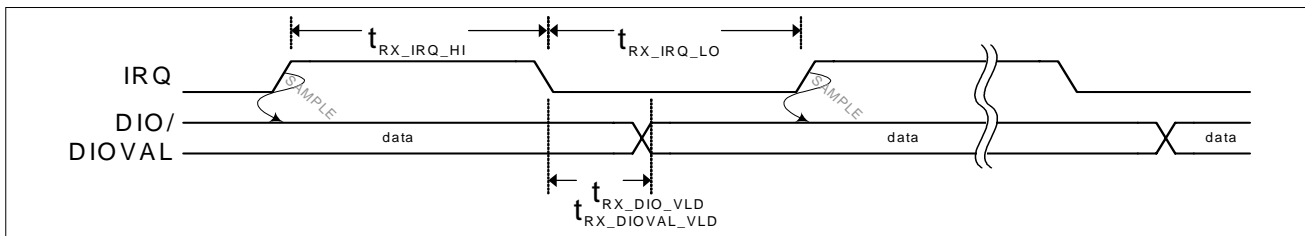
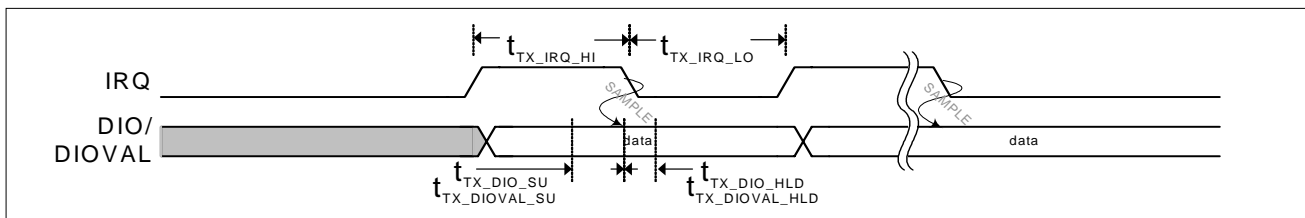
Parameter	Description				Unit
		Min.	Typ.	Max.	
Transmit					
$t_{TX_DIOVAL_SU}$	DIOVAL Set-up Time	2.1			μs
$t_{TX_DIO_SU}$	DIO Set-up Time	2.1			μs
$t_{TX_DIOVAL_HLD}$	DIOVAL Hold Time	0			μs
$t_{TX_DIO_HLD}$	DIO Hold Time	0			μs
$t_{TX_IRQ_HI}$	Minimum IRQ High Time - 32 chips/bit DDR		8		μs
	Minimum IRQ High Time - 32 chips/bit		16		μs
	Minimum IRQ High Time - 64 chips/bit		32		μs
$t_{TX_IRQ_LO}$	Minimum IRQ Low Time - 32 chips/bit DDR		8		μs
	Minimum IRQ Low Time - 32 chips/bit		16		μs
	Minimum IRQ Low Time - 64 chips/bit		32		μs
Receive		Min.	Typ.	Max.	Unit
$t_{RX_DIOVAL_VLD}$	DIOVAL Valid Time - 32 chips/bit DDR	-0.01		6.1	μs
	DIOVAL Valid Time - 32 chips/bit	-0.01		8.2	μs
	DIOVAL Valid Time - 64 chips/bit	-0.01		16.1	μs
$t_{RX_DIO_VLD}$	DIO Valid Time - 32 chips/bit DDR	-0.01		6.1	μs
	DIO Valid Time - 32 chips/bit	-0.01		8.2	μs
	DIO Valid Time - 64 chips/bit	-0.01		16.1	μs
$t_{RX_IRQ_HI}$	Minimum IRQ High Time - 32 chips/bit DDR		1		μs
	Minimum IRQ High Time - 32 chips/bit		1		μs
	Minimum IRQ High Time - 64 chips/bit		1		μs
$t_{RX_IRQ_LO}$	Minimum IRQ Low Time - 32 chips/bit DDR		8		μs
	Minimum IRQ Low Time - 32 chips/bit		16		μs
	Minimum IRQ Low Time - 64 chips/bit		32		μs

Figure 12-3. DIO Receive Timing Diagram

Figure 12-4. DIO Transmit Timing Diagram

12.1 Radio Parameters
Table 12-3. Radio Parameters

Parameter Description	Conditions	Min.	Typ.	Max.	Unit
RF Frequency Range	[19]	2.400		2.483	GHz
Radio Receiver ($T = 25^{\circ}\text{C}$, $V_{\text{CC}} = 3.3\text{V}$, $f_{\text{osc}} = 13.000\text{ MHz}$, X13OUT off, 64 chips/bit, Threshold Low = 8, Threshold High = 56, $\text{BER} \leq 10^{-3}$)					
Sensitivity			-90		dBm
Maximum Received Signal		-20	-10		dBm
RSSI value for $\text{PWR}_{\text{in}} > -40\text{ dBm}$			28 - 31		
RSSI value for $\text{PWR}_{\text{in}} < -95\text{ dBm}$			0 - 10		
Interference Performance					
Co-channel Interference rejection Carrier-to-Interference (C/I)	$C = -60\text{ dBm}$		11		dB
Adjacent (1 MHz) channel selectivity C/I 1 MHz	$C = -60\text{ dBm}$		3		dB
Adjacent (2 MHz) channel selectivity C/I 2 MHz	$C = -60\text{ dBm}$		-30		dB
Adjacent ($\geq 3\text{ MHz}$) channel selectivity $C/I \geq 3\text{ MHz}$	$C = -67\text{ dBm}$		-40		dB
Image ^[21] Frequency Interference, C/I Image	$C = -67\text{ dBm}$		-20		dB
Adjacent (1 MHz) interference to in-band image frequency, C/I image $\pm 1\text{ MHz}$	$C = -67\text{ dBm}$		-25		dB
Out-of-Band Blocking Interference Signal Frequency					
30 MHz – 2399 MHz, except (FO/N & FO/N $\pm 1\text{ MHz}$) ^[18]	$C = -67\text{ dBm}$		-30		dBm
2498 MHz – 12.75 GHz, except (FO*N & FO*N $\pm 1\text{ MHz}$) ^[18]	$C = -67\text{ dBm}$		-20		dBm
Intermodulation	$C = -64\text{ dBm}$, $\Delta f = 5, 10\text{ MHz}$		-39		dBm
Spurious Emission					
30 MHz – 1 GHz				-57	dBm
1 GHz – 12.75 GHz except (4.8 GHz - 5.0 GHz)				-54	dBm
4.8 GHz – 5.0 GHz				-40 ^[20]	dBm
Radio Transmitter ($T = 25^{\circ}\text{C}$, $V_{\text{CC}} = 3.3\text{V}$, $f_{\text{osc}} = 13.000\text{ MHz}$)					
Maximum RF Transmit Power	PA = 7		0		dBm
RF Power Control Range			30		dB
RF Power Range Control Step Size	seven steps, monotonic		4.3		dB
Frequency Deviation	PN Code Pattern 10101010		270		kHz
Frequency Deviation	PN Code Pattern 11110000		320		kHz
Zero Crossing Error			± 125		ns
Occupied Bandwidth	100-kHz resolution bandwidth, -6 dBc	500			kHz
Initial Frequency Offset			± 75		kHz
In-band Spurious					
Second Channel Power ($\pm 2\text{ MHz}$)				-30	dBm
\geq Third Channel Power ($\geq 3\text{ MHz}$)				-40	dBm
Non-Harmonically Related Spurs					
30 MHz – 12.75 GHz				-54	dBm
Harmonic Spurs					
Second Harmonic				-28	dBm
Third Harmonic				-25	dBm
Fourth and Greater Harmonics				-42	dBm

Notes:

18. FO = Tuned Frequency, N = Integer.

19. Subject to regulation.

20. Antenna matching network and antenna will attenuate the output signal at these frequencies to meet regulatory requirements.

21. Image frequency is +4 MHz from desired channel (2 MHz low IF, high side injection).

12.2 Power Management Timing

Table 12-4. Power Management Timing (The values below are dependent upon oscillator network component selection)^[26]

Parameter	Description	Conditions	Min.	Typ	Max.	Unit
t_{PDN_X13}	Time from PD deassert to X13OUT			2000		μs
t_{SPL_RDY}	Time from oscillator stable to start of SPI transactions		1			μs
t_{PWR_RST}	Power On to RESET deasserted	$V_{CC} @ 2.7\text{V}$	1300			μs
t_{RST}	Minimum RESET asserted pulse width		1			μs
t_{PWR_PD}	Power On to PD deasserted ^[22]		1300			μs
t_{WAKE}	PD deassert to clocks running ^[23]			2000		μs
t_{PD}	Minimum PD asserted pulse width		10			μs
t_{SLEEP}	PD assert to low power mode			50		ns
t_{WAKE_INT}	PD deassert to IRQ ^[24] assert (wake interrupt) ^[25]			2000		μs
t_{STABLE}	PD deassert to clock stable	to within ± 10 ppm		2100		μs
$t_{STABLE2}$	IRQ assert (wake interrupt) to clock stable	to within ± 10 ppm		2100		us

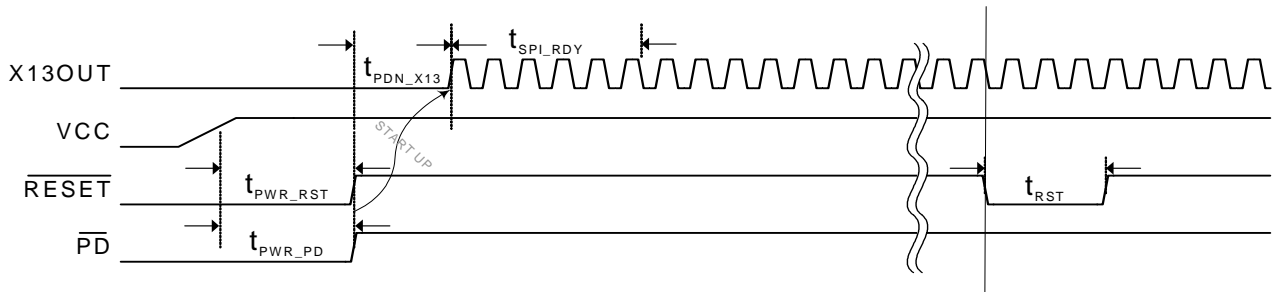

Figure 12-5. Power On Reset/Reset Timing

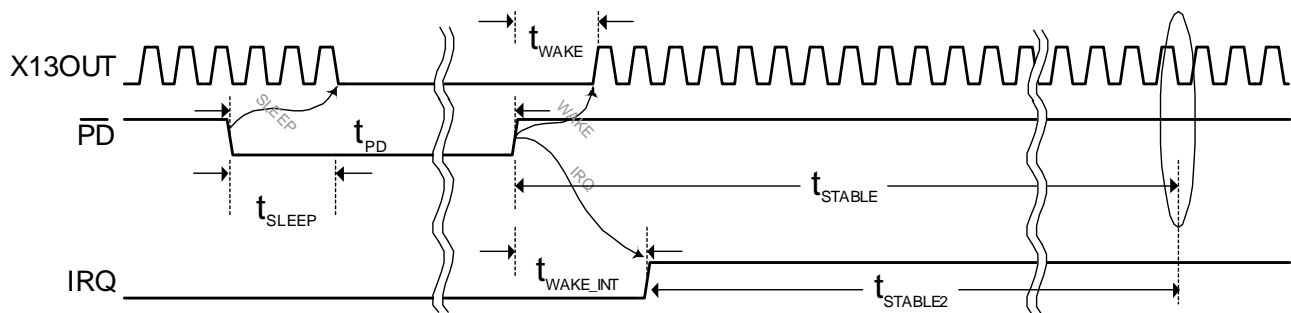

Figure 12-6. Sleep / Wake Timing

Notes:

22. The $\overline{\text{PD}}$ pin must be asserted at power up to ensure proper crystal startup.
23. When X13OUT is enabled.
24. Both the polarity and the drive method of the IRQ pin are programmable. See *page 9* for more details. *Figure 12-6* illustrates default values for the Configuration register (Reg 0x05, bits 1:0).
25. A wakeup event is triggered when the $\overline{\text{PD}}$ pin is deasserted. *Figure 12-6* illustrates a wakeup event configured to trigger an IRQ pin event via the Wake Enable register (Reg 0x1C, bit 0=1).
26. Measured with CTS ATXN6077A crystal.

12.3 AC Test Loads and Waveforms for Digital Pins

AC Test Loads

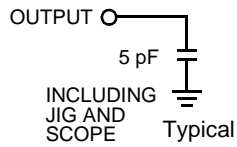
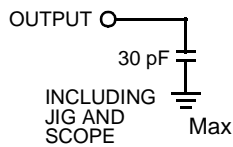

DC Test Load

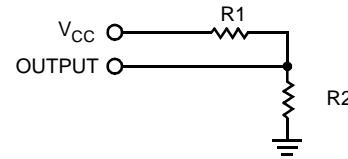

Parameter		Unit
R1	1071	Ω
R2	937	Ω
R _{TH}	500	Ω
V _{TH}	1.4	V
V _{CC}	3.00	V

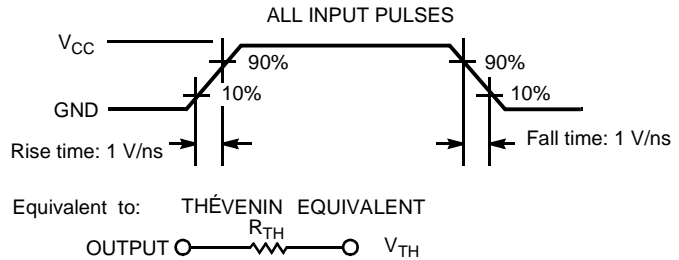

Figure 12-7. AC Test Loads and Waveforms for Digital Pins

13.0 Ordering Information

Table 13-1. Ordering Information

Part Number	Radio	Package Name	Package Type	Operating Range
CYWUSB6932-48LFXC	Transmitter	48 QFN	48 Quad Flat Package No Leads Lead-Free	Commercial
CYWUSB6934-48LFXC	Transceiver	48 QFN	48 Quad Flat Package No Leads Lead-Free	Commercial

14.0 Package Description

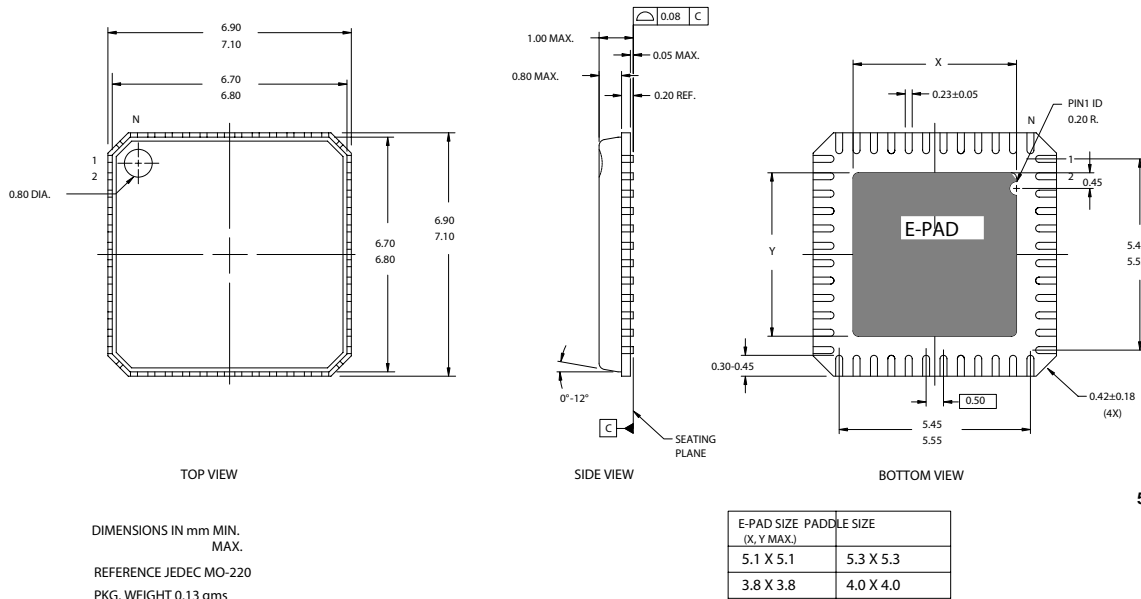

Figure 14-1. 48-pin Lead-Free QFN 7 x 7 mm LY48

The recommended dimension of the PCB pad size for the E-PAD underneath the QFN is 209 mils x 209 mils (width x length).

This document is subject to change, and may be found to contain errors of omission or changes in parameters. For feedback or technical support regarding Cypress WirelessUSB products please contact Cypress at www.cypress.com. WirelessUSB, PSoC, and enCoRe are trademarks of Cypress Semiconductor. All product and company names mentioned in this document are the trademarks of their respective holders.

Document History Page

Document Title: CYWUSB6932/CYWUSB6934 WirelessUSB™ LS 2.4-GHz DSSS Radio SoC				
Document Number: 38-16007				
REV.	ECN NO.	Issue Date	Orig. of Change	Description of Change
**	123907	01/20/03	LXA	New data sheet
*A	125470	04/28/03	XGR	Preliminary release
*B	127076	07/30/03	KKU	Updated pinouts, timing diagrams, AC Test loads, DC Characteristics, Radio Characteristics Removed die
*C	128886	08/04/03	KKV	Minor change: removed table of contents and fixed layout of section 10.
*D	129180	12/04/03	TGE	Updated AC and DC characteristics from char. results Updated register entries Changed package type from 56-pin QFN to 48-pin QFN Updated all pinouts and timing diagrams Updated block diagram and functional description Updated application interfaces Added Interrupt descriptions
*E	131851	12/15/03	TGE	Changed Static Discharge Voltage (Digital) Specification of Section 9.0
*F	241471	See ECN	ZTK	Removed Static Discharge Voltage (Digital) Specification of Section 9.0 footnote Updated REG_DATA_RATE (0x04), 111—Not Valid Swapped bit field descriptions of REG_CONFIG Corrected <i>Figure 3-1</i> and <i>Figure 6-2</i> Minor edits throughout
*G	284810	See ECN	ZTK	Removed SOIC package option Updated ordering information section Added <i>Table 4-1</i> Internal PA Output Power Step Table Added t_{TABLE2} Parameter to <i>Table 12-4</i> and <i>Figure 12-6</i> Corrected <i>Figure 14-1</i> caption Corrected <i>Figure 6-2</i> to show QFN matching network Removed Addr 0x01 and 0x02 - unused Updated <i>Figure 8-1</i> Updated Spurious Emissions parameters



LittleDiode supplies new, hard to find or obsolete electronic components and semiconductors all over the world.

With over two million different components listed you are sure to find the part you need.

Feel free to visit us today at our online store:

LittleDiode.com

Looking forward to providing you with the best possible service.