

## 54LS169/DM54LS169A/DM74LS169A Synchronous 4-Bit Up/Down Binary Counter

### General Description

This synchronous presettable counter features an internal carry look-ahead for cascading in high-speed counting applications. Synchronous operation is provided by having all flip-flops clocked simultaneously, so that the outputs all change at the same time when so instructed by the count-enable inputs and internal gating. This mode of operation helps eliminate the output counting spikes that are normally associated with asynchronous (ripple clock) counters. A buffered clock input triggers the four master-slave flip-flops on the rising edge of the clock waveform.

This counter is fully programmable; that is, the outputs may each be preset either high or low. The load input circuitry allows loading with the carry-enable output of cascaded counters. As loading is synchronous, setting up a low level at the load input disables the counter and causes the outputs to agree with the data inputs after the next clock pulse.

The carry look-ahead circuitry permits cascading counters for n-bit synchronous applications without additional gating. Both count-enable inputs ( $\bar{P}$  and  $\bar{T}$ ) must be low to count. The direction of the count is determined by the level of the up/down input. When the input is high, the counter counts up; when low, it counts down. Input  $\bar{T}$  is fed forward to enable the carry outputs. The carry output thus enabled will produce a low-level output pulse with a duration approximately equal to the high portion of the  $Q_A$  output when

counting up, and approximately equal to the low portion of the  $Q_A$  output when counting down. This low-level overflow carry pulse can be used to enable successively cascaded stages. Transitions at the enable  $\bar{P}$  or  $\bar{T}$  inputs are allowed regardless of the level of the clock input. All inputs are diode clamped to minimize transmission-line effects, thereby simplifying system design.

This counter features a fully independent clock circuit. Changes at control inputs (enable  $\bar{P}$ , enable  $\bar{T}$ , load, up/down), which modify the operating mode, have no effect until clocking occurs. The function of the counter (whether enabled, disabled, loading, or counting) will be dictated solely by the conditions meeting the stable setup and hold times.

### Features

- Fully synchronous operation for counting and programming.
- Internal look-ahead for fast counting.
- Carry output for n-bit cascading.
- Fully independent clock circuit
- Alternate Military/Aerospace device (54LS169) is available. Contact a National Semiconductor Sales Office/Distributor for specifications.

### Connection Diagram

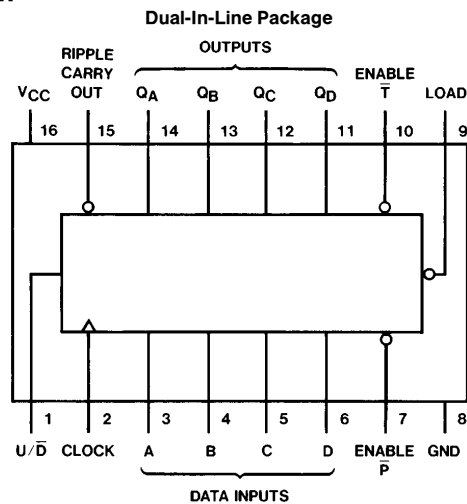

TL/F/6401-1

Order Number 54LS169DMQB, 54LS169FMQB, 54LS169LMQB,  
DM54LS169AJ, DM54LS169AW, DM74LS169AM or DM74LS169AN  
See NS Package Number E20A, J16A, M16A, N16E or W16A

## Absolute Maximum Ratings (Note)

If Military/Aerospace specified devices are required, please contact the National Semiconductor Sales Office/Distributors for availability and specifications.

Supply Voltage	7V
Input Voltage	7V
Operating Free Air Temperature Range	
DM54LS and 54LS	−55°C to +125°C
DM74LS	0°C to +70°C
Storage Temperature Range	−65°C to +150°C

Note: The "Absolute Maximum Ratings" are those values beyond which the safety of the device cannot be guaranteed. The device should not be operated at these limits. The parametric values defined in the "Electrical Characteristics" table are not guaranteed at the absolute maximum ratings. The "Recommended Operating Conditions" table will define the conditions for actual device operation.

## Recommended Operating Conditions

Symbol	Parameter	DM54LS169A			DM74LS169A			Units
		Min	Nom	Max	Min	Nom	Max	
V <sub>CC</sub>	Supply Voltage	4.5	5	5.5	4.75	5	5.25	V
V <sub>IH</sub>	High Level Input Voltage	2			2			V
V <sub>IL</sub>	Low Level Input Voltage			0.7			0.8	V
I <sub>OH</sub>	High Level Output Current			−0.4			−0.4	mA
I <sub>OL</sub>	Low Level Output Current			4			8	mA
f <sub>CLK</sub>	Clock Frequency (Note 1)	0		25	0		25	MHz
	Clock Frequency (Note 2)	0		20	0		20	MHz
t <sub>w</sub>	Clock Pulse Width (Note 3)	25			25			ns
t <sub>su</sub>	Setup Time (Note 3)	Data	20		20			ns
		Enable $\bar{T}$ or $\bar{P}$	20		20			
		Load	25		25			
		U/D	30		30			
t <sub>H</sub>	Hold Time (Note 3)	0			0			ns
T <sub>A</sub>	Free Air Operating Temperature	−55		125	0		70	°C

Note 1: C<sub>L</sub> = 15 pF, R<sub>L</sub> = 2 kΩ, T<sub>A</sub> = 25°C and V<sub>CC</sub> = 5V.

Note 2: C<sub>L</sub> = 50 pF, R<sub>L</sub> = 2 kΩ, T<sub>A</sub> = 25°C and V<sub>CC</sub> = 5V.

Note 3: T<sub>A</sub> = 25°C and V<sub>CC</sub> = 5V.

## Electrical Characteristics over recommended operating free air temperature range (unless otherwise noted)

Symbol	Parameter	Conditions	Min	Typ (Note 4)	Max	Units
V <sub>I</sub>	Input Clamp Voltage	V <sub>CC</sub> = Min, I <sub>I</sub> = −18 mA			−1.5	V
V <sub>OH</sub>	High Level Output Voltage	V <sub>CC</sub> = Min, I <sub>OH</sub> = Max V <sub>IL</sub> = Max, V <sub>IH</sub> = Min	DM54	2.5	3.4	V
			DM74	2.7	3.4	
V <sub>OL</sub>	Low Level Output Voltage	V <sub>CC</sub> = Min, I <sub>OL</sub> = Max V <sub>IL</sub> = Max, V <sub>IH</sub> = Min	DM54		0.25	V
			DM74		0.35	
			DM74		0.25	
I <sub>I</sub>	Input Current @ Max Input Voltage	V <sub>CC</sub> = Max V <sub>I</sub> = 7V	Enable $\bar{T}$		0.2	mA
			Others		0.1	
I <sub>IH</sub>	High Level Input Current	V <sub>CC</sub> = Max V <sub>I</sub> = 2.7V	Enable $\bar{T}$		40	μA
			Others		20	
I <sub>IL</sub>	Low Level Input Current	V <sub>CC</sub> = Max V <sub>I</sub> = 0.4V	Enable $\bar{T}$		−0.8	mA
			Others		−0.4	
I <sub>OS</sub>	Short Circuit Output Current	V <sub>CC</sub> = Max (Note 5)	DM54	−20	−100	mA
			DM74	−20	−100	
I <sub>CC</sub>	Supply Current	V <sub>CC</sub> = Max (Note 6)		20	34	mA

Note 4: All typicals are at V<sub>CC</sub> = 5V and T<sub>A</sub> = 25°C.

Note 5: Not more than one output should be shorted at a time, and the duration should not exceed one second.

Note 6: I<sub>CC</sub> is measured after a momentary 4.5V, then ground, is applied to the CLOCK with all other inputs grounded and all the outputs open.

### Switching Characteristics at $V_{CC} = 5V$ and $T_A = 25^\circ C$ (See Section 1 for Test Waveforms and Output Load)

Symbol	Parameter	From (Input) To (Output)	$R_L = 2\text{ k}\Omega$				Units
			$C_L = 15\text{ pF}$		$C_L = 50\text{ pF}$		
			Min	Max	Min	Max	
$f_{MAX}$	Maximum Clock Frequency		25		20		MHz
$t_{PLH}$	Propagation Delay Time Low to High Level Output	Clock to Ripple Carry		35		39	ns
$t_{PHL}$	Propagation Delay Time High to Low Level Output	Clock to Ripple Carry		35		44	ns
$t_{PLH}$	Propagation Delay Time Low to High Level Output	Clock to Any Q		20		24	ns
$t_{PHL}$	Propagation Delay Time High to Low Level Output	Clock to Any Q		23		32	ns
$t_{PLH}$	Propagation Delay Time Low to High Level Output	Enable $\bar{T}$ to Ripple Carry		18		24	ns
$t_{PHL}$	Propagation Delay Time High to Low Level Output	Enable $\bar{T}$ to Ripple Carry		18		28	ns
$t_{PLH}$	Propagation Delay Time Low to High Level Output	Up/Down to Ripple Carry (Note 1)		25		30	ns
$t_{PHL}$	Propagation Delay Time High to Low Level Output	Up/Down to Ripple Carry (Note 1)		29		38	ns

**Note 1:** The propagation delay from UP/DOWN to RIPPLE CARRY must be measured with the counter at either a minimum or a maximum count. As the logic level of the up/down input is changed, the ripple carry output will follow. If the count is minimum, the ripple carry output transition will be in phase. If the count is maximum, the ripple carry output will be out of phase.

# Logic Diagram

## LS169A Binary Counter

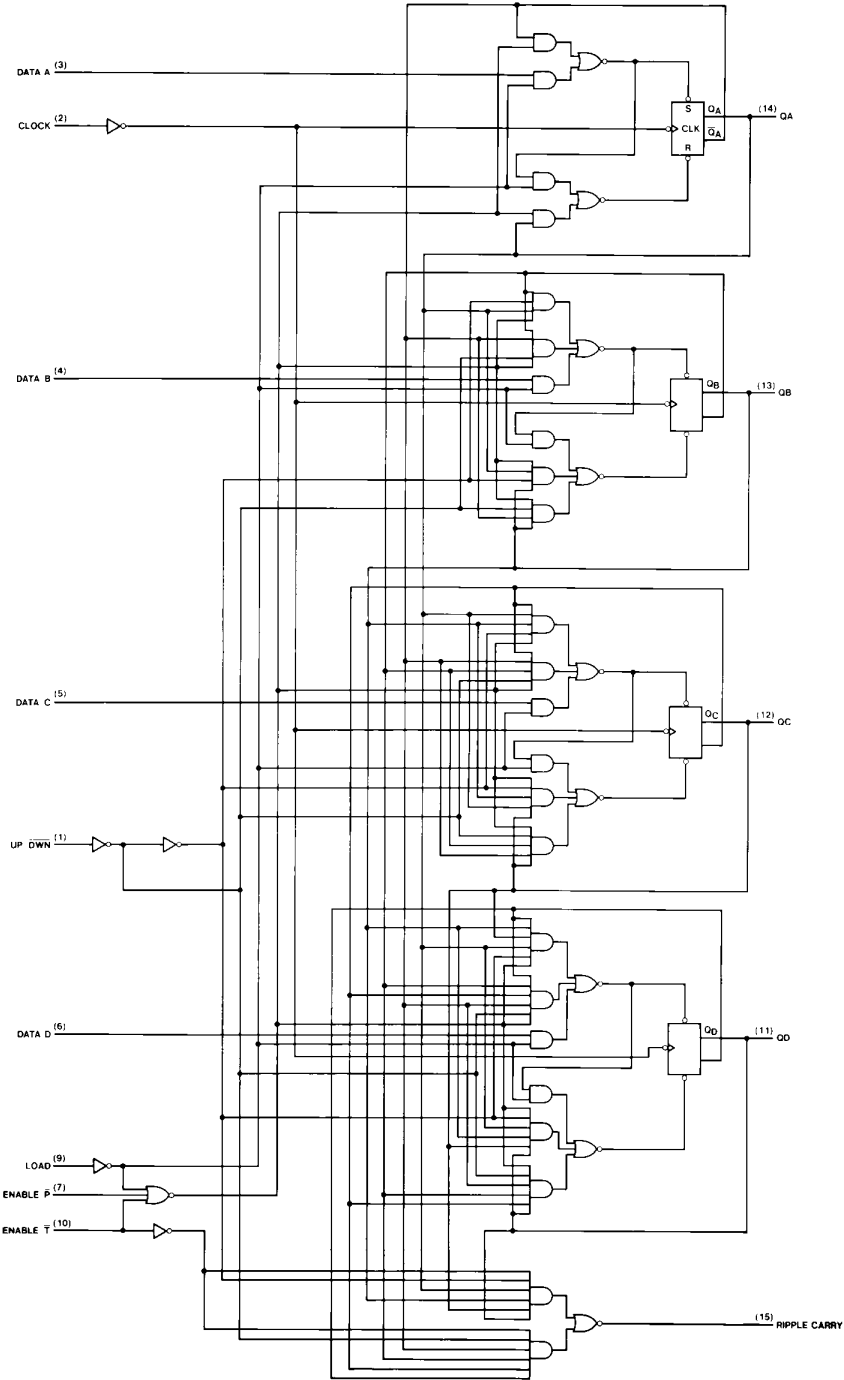

TL/F/6401-2

# Timing Diagram

LS169A Binary Counters  
Typical Load, Count, and Inhibit Sequences

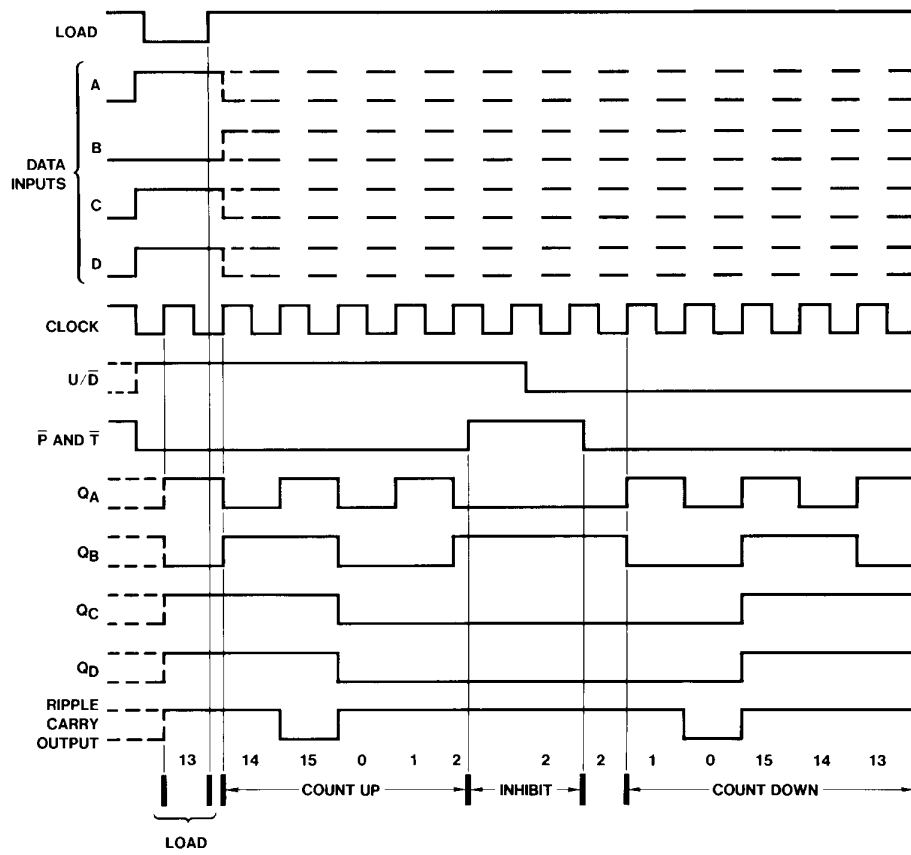

TL/F/6401-3

**Physical Dimensions** inches (millimeters)

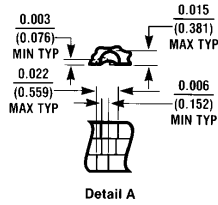
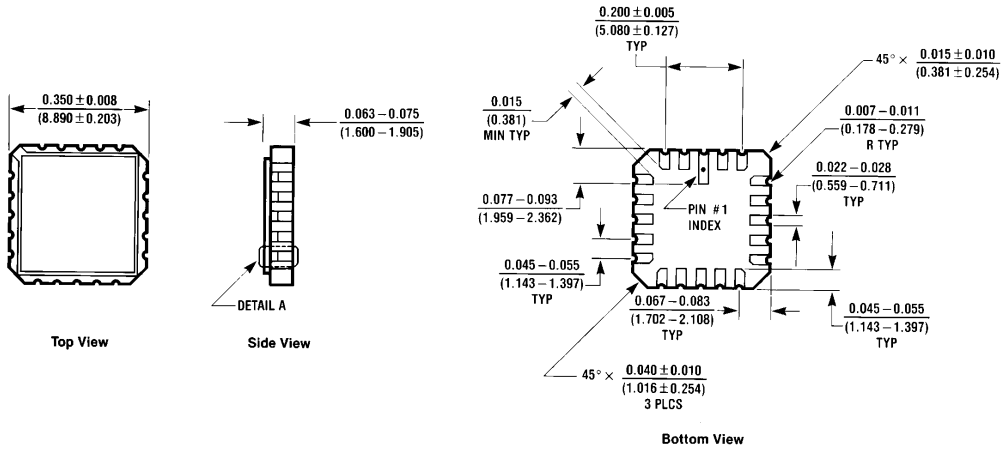

**Ceramic Leadless Chip Carrier Package (E)**  
**Order Number 54LS169LMQB**  
**NS Package Number E20A**

E20A (REV D)

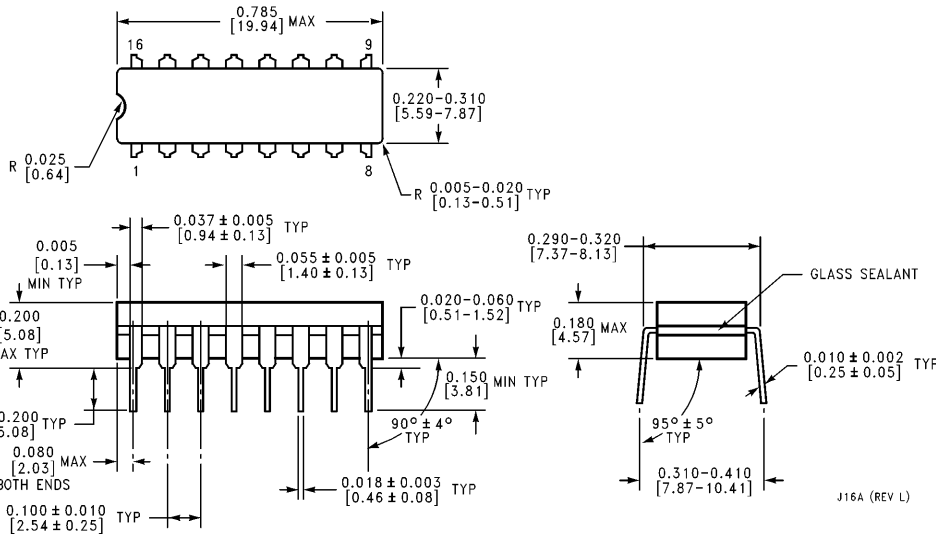

**16-Lead Ceramic Dual-In-Line Package (J)**  
**Order Number 54LS169DMQB or DM54LS169AJ**  
**NS Package Number J16A**

J16A (REV L)

**Physical Dimensions** inches (millimeters) (Continued)

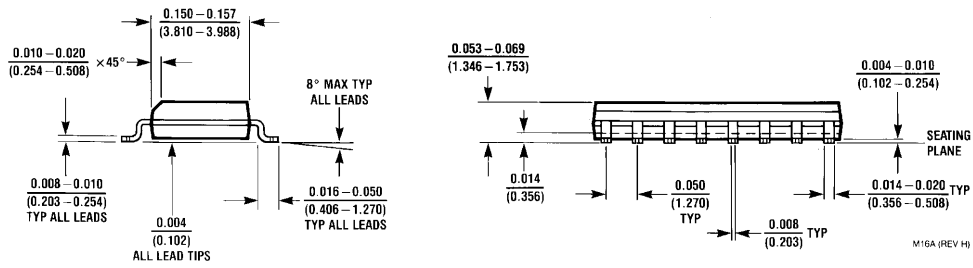
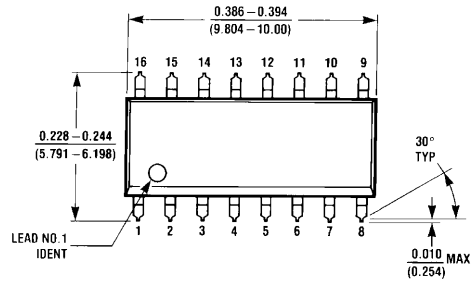

**16-Lead Small Outline Molded Package (M)**  
**Order Number DM74LS169AM**  
**NS Package Number M16A**

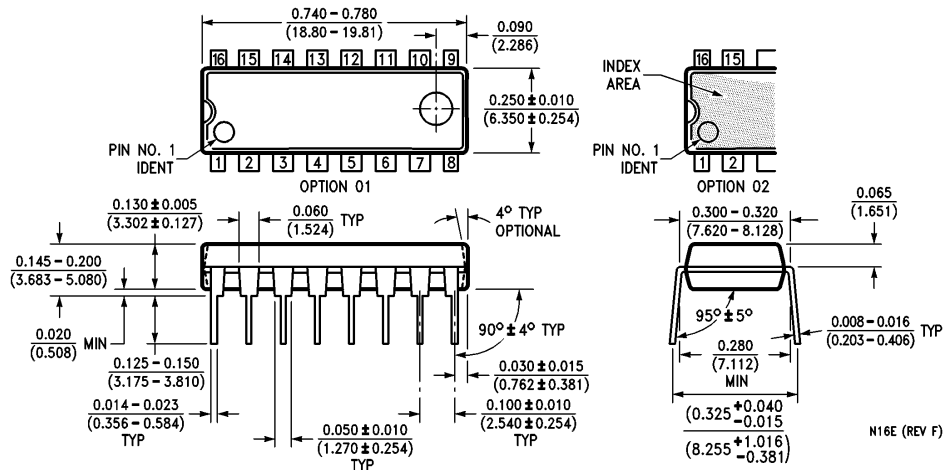

**16-Lead Molded Dual-In-Line Package (N)**  
**Order Number DM74LS169AN**  
**NS Package Number N16E**

**54LS169/DM54LS169A/DM74LS169A**  
**Synchronous 4-Bit Up/Down Binary Counter**

**Physical Dimensions** inches (millimeters) (Continued)

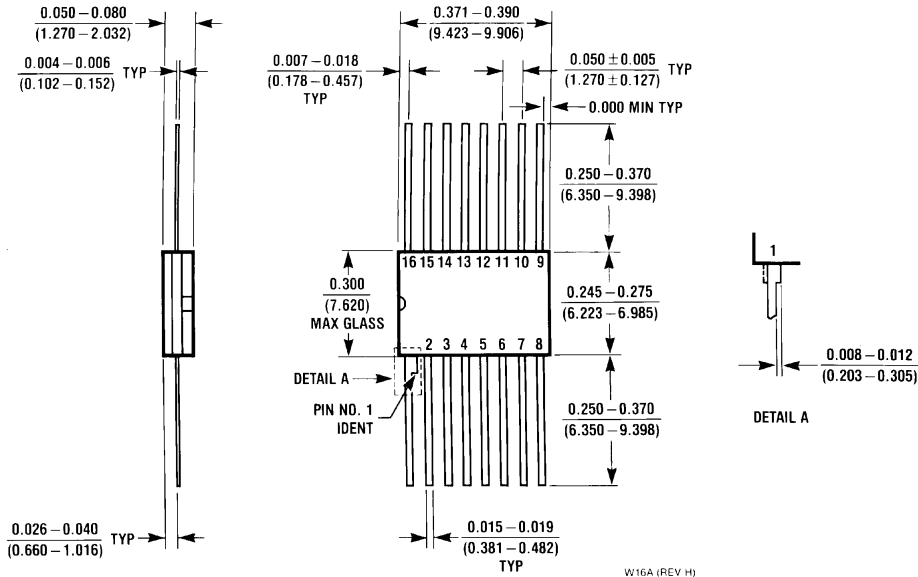

**16-Lead Ceramic Flat Package (W)**  
**Order Number 54LS169MQB or DM54LS169AW**  
**NS Package Number W16A**

**LIFE SUPPORT POLICY**

NATIONAL'S PRODUCTS ARE NOT AUTHORIZED FOR USE AS CRITICAL COMPONENTS IN LIFE SUPPORT DEVICES OR SYSTEMS WITHOUT THE EXPRESS WRITTEN APPROVAL OF THE PRESIDENT OF NATIONAL SEMICONDUCTOR CORPORATION. As used herein:

1. Life support devices or systems are devices or systems which, (a) are intended for surgical implant into the body, or (b) support or sustain life, and whose failure to perform, when properly used in accordance with instructions for use provided in the labeling, can be reasonably expected to result in a significant injury to the user.
2. A critical component is any component of a life support device or system whose failure to perform can be reasonably expected to cause the failure of the life support device or system, or to affect its safety or effectiveness.



**National Semiconductor Corporation**  
 1111 West Bardin Road  
 Arlington, TX 76017  
 Tel: 1(800) 272-9959  
 Fax: 1(800) 737-7018

**National Semiconductor Europe**  
 Fax: (+49) 0-180-530 85 86  
 Email: onjwge@tevm2.nsc.com  
 Deutsch Tel: (+49) 0-180-530 85 85  
 English Tel: (+49) 0-180-532 78 32  
 Français Tel: (+49) 0-180-532 93 58  
 Italiano Tel: (+49) 0-180-534 16 80

**National Semiconductor Hong Kong Ltd.**  
 13th Floor, Straight Block,  
 Ocean Centre, 5 Canton Rd.  
 Tsimshatsui, Kowloon  
 Hong Kong  
 Tel: (852) 2737-1600  
 Fax: (852) 2736-9960

**National Semiconductor Japan Ltd.**  
 Tel: 81-043-299-2309  
 Fax: 81-043-299-2408

National does not assume any responsibility for use of any circuitry described, no circuit patent licenses are implied and National reserves the right at any time without notice to change said circuitry and specifications.

This datasheet has been downloaded from:

[www.DatasheetCatalog.com](http://www.DatasheetCatalog.com)

Datasheets for electronic components.

# National Semiconductor was acquired by Texas Instruments.

[http://www.ti.com/corp/docs/investor\\_relations/pr\\_09\\_23\\_2011\\_national\\_semiconductor.html](http://www.ti.com/corp/docs/investor_relations/pr_09_23_2011_national_semiconductor.html)

This file is the datasheet for the following electronic components:

DM54LS169AJ - <http://www.ti.com/product/dm54ls169aj?HQS=TI-null-null-dscatalog-df-pf-null-wwe>

DM54LS169AW - <http://www.ti.com/product/dm54ls169aw?HQS=TI-null-null-dscatalog-df-pf-null-wwe>



LittleDiode supplies new, hard to find or obsolete electronic components and semiconductors all over the world.

With over two million different components listed you are sure to find the part you need.

Feel free to visit us today at our online store:

[LittleDiode.com](http://LittleDiode.com)

Looking forward to providing you with the best possible service.