

DM54181 Arithmetic Logic Unit/Function Generators

General Description

These arithmetic logic units (ALU)/function generators perform 16 binary arithmetic operations on two 4-bit words, as shown in Tables I and II. These operations are selected by the four function-select lines (S0, S1, S2, S3) and include addition, subtraction, decrement, and straight transfer. When performing arithmetic manipulations, the internal carries must be enabled by applying a low-level voltage to the mode control input (M). A full carry look-ahead scheme is available in these devices for fast, simultaneous carry generation by means of two cascade-outputs (P and G) for the four bits in the package. When used in conjunction with the DM54S182 full carry look-ahead circuits, high-speed arithmetic operations can be performed. The typical addition times shown below illustrate how little time is required for addition of longer words, when full carry look-ahead is employed. The method of cascading 182 circuits with these ALU's to provide multi-level full carry look-ahead is illustrated under typical applications data for the DM54S182.

(Continued)

Features

- Arithmetic operating modes:
 - Addition
 - Subtraction
 - Shift operand A one position
 - Magnitude comparison
 - Plus twelve other arithmetic operations
- Logic function modes:
 - EXCLUSIVE-OR
 - Comparator
 - AND, NAND, OR, NOR
 - Plus ten other logic operations
- Full look-ahead for high-speed operations on long words

Connection Diagram

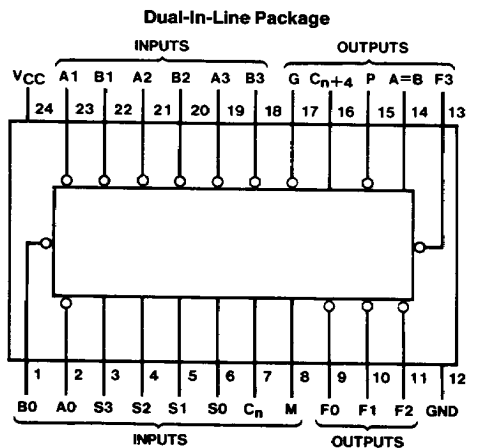

TL/F/6560-1

Order Number DM54181J
See NS Package Number J24A

Pin Designations

Designation	Pin Nos.	Function
A3, A2, A1, A0	19, 21, 23, 2	Word A Inputs
B3, B2, B1, B0	18, 20, 22, 1	Word B Inputs
S3, S2, S1, S0	3, 4, 5, 6	Function-Select Inputs
C _n	7	Inv. Carry Input
M	8	Mode Control Input
F3, F2, F1, F0	13, 11, 10, 9	Function Outputs
A = B	14	Comparator Output
P	15	Carry Propagate Output
C _{n+4}	16	Inv. Carry Output
G	17	Carry Generate Output
V _{CC}	24	Supply Voltage
GND	12	Ground

Number of Bits	Typical Addition Times	Package Count		Carry Method Between ALU's
		Arithmetic/Logic Units	Look Ahead Carry Generators	
1 to 4	20 ns	1	0	None
5 to 8	30 ns	2	0	Ripple
9 to 16	30 ns	3 or 4	1	Full Look-Ahead
17 to 64	50 ns	5 to 16	2 to 5	Full Look-Ahead

Absolute Maximum Ratings (Note)

If Military/Aerospace specified devices are required, please contact the National Semiconductor Sales Office/Distributors for availability and specifications.

Supply Voltage	7V
Input Voltage	5.5V
Output Voltage (A = B Output)	5.5V
Operating Free Air Temperature Range DM54	-55°C to +125°C
Storage Temperature Range	-65°C to +150°C

Note: The "Absolute Maximum Ratings" are those values beyond which the safety of the device cannot be guaranteed. The device should not be operated at these limits. The parametric values defined in the "Electrical Characteristics" table are not guaranteed at the absolute maximum ratings. The "Recommended Operating Conditions" table will define the conditions for actual device operation.

Recommended Operating Conditions

Symbol	Parameter	DM54181			Units
		Min	Nom	Max	
V _{CC}	Supply Voltage	4.5	5	5.5	V
V _{IH}	High Level Input Voltage	2			V
V _{IL}	Low Level Input Voltage			0.8	V
V _{OH}	High Level Output Voltage (A = B Output)			5.5	V
I _{OH}	High Level Output Current (All Except A = B)			-800	μA
I _{OL}	Low Level Output Current			16	mA
T _A	Free Air Operating Temperature	-55		125	°C

Electrical Characteristics over recommended operating free air temperature range (unless otherwise noted)

Symbol	Parameter	Conditions	Min	Typ (Note 1)	Max	Units
V _I	Input Clamp Voltage	V _{CC} = Min, I _I = -12 mA			-1.5	V
I _{CEX}	High Level Output Current (A = B Output)	V _{CC} = Min, V _O = 5.5V V _{IL} = Max, V _{IH} = Min			250	μA
V _{OH}	High Level Output Voltage (All Except A = B)	V _{CC} = Min, I _{OH} = Max V _{IL} = Max, V _{IH} = Min	2.4			V
V _{OL}	Low Level Output Voltage	V _{CC} = Min, I _{OL} = Max V _{IH} = Min, V _{IL} = Max			0.4	V
I _I	Input Current @ Max Input Voltage	V _{CC} = Max, V _I = 5.5V			1	mA
I _{IH}	High Level Input Current	V _{CC} = Max V _I = 2.4V	Mode		40	μA
			A or B		120	
			S		160	
			Carry		200	
I _{IL}	Low Level Input Current	V _{CC} = Max V _I = 0.4V	Mode		-1.6	mA
			A or B		-4.8	
			S		-6.4	
			Carry		-8	
I _{OS}	Short Circuit Output Current (All Except A = B)	V _{CC} = Max V _I = 2.4V	-20		-55	mA
I _{CCH}	Supply Current with Outputs High	V _{CC} = Max (Note 3)		88	127	mA
I _{CCL}	Supply Current with Outputs Low	V _{CC} = Max (Note 4)		92	135	mA

Note 1: All typicals are at V_{CC} = 5V, T_A = 25°C.

Note 2: Not more than one output should be shorted at a time.

Note 3: I_{CCH} is measured with S0 through S3, M, and A inputs at 4.5V, all other inputs grounded and all outputs open.

Note 4: I_{CCL} is measured with S0 through S3 and M inputs at 4.5V, all other inputs grounded and all outputs open.

Switching Characteristics $V_{CC} = 5V$, $T_A = 25^\circ C$ (See Section 1 for Test Waveforms and Output Load)

Symbol	Parameter	From (Input)	To (Output)	Conditions	DM54181		Units
					$R_L = 400\Omega$, $C_L = 15\text{ pF}$		
					Min	Max	
t_{PLH}	Propagation Delay Time, Low-to-High Level Output	C_n	$C_n + 4$			18	ns
t_{PHL}	Propagation Delay Time, High-to-Low Level Output					19	
t_{PLH}	Propagation Delay Time, Low-to-High Level Output	Any A or B	$C_n + 4$	$M = 0V$, $S_0 = S_3 = 4.5V$ $S_1 = S_2 = 0V$ (SUM mode)		30	ns
t_{PHL}	Propagation Delay Time, High-to-Low Level Output					33	
t_{PLH}	Propagation Delay Time, Low-to-High Level Output	Any A or B	$C_n + 4$	$M = 0V$, $S_0 = S_3 = 0V$ $S_1 = S_2 = 4.5V$ (DIFF mode)		30	ns
t_{PHL}	Propagation Delay Time, High-to-Low Level Output					33	
t_{PLH}	Propagation Delay Time, Low-to-High Level Output	C_n	Any F	$M = 0V$ (SUM or DIFF mode)		19	ns
t_{PHL}	Propagation Delay Time, High-to-Low Level Output					18	
t_{PLH}	Propagation Delay Time, Low-to-High Level Output	Any A or B	G	$M = 0V$, $S_0 = S_3 = 4.5V$ $S_1 = S_2 = 0V$ (SUM mode)		19	ns
t_{PHL}	Propagation Delay Time, High-to-Low Level Output					19	
t_{PLH}	Propagation Delay Time, Low-to-High Level Output	Any A or B	G	$M = 0V$, $S_0 = S_3 = 0V$ $S_1 = S_2 = 4.5V$ (DIFF mode)		20	ns
t_{PHL}	Propagation Delay Time, High-to-Low Level Output					25	
t_{PLH}	Propagation Delay Time, Low-to-High Level Output	Any A or B	P	$M = 0V$, $S_0 = S_3 = 4.5V$ $S_1 = S_2 = 0V$ (SUM mode)		19	ns
t_{PHL}	Propagation Delay Time, High-to-Low Level Output					25	
t_{PLH}	Propagation Delay Time, Low-to-High Level Output	Any A or B	P	$M = 0V$, $S_0 = S_3 = 0V$ $S_1 = S_2 = 4.5V$ (DIFF mode)		25	ns
t_{PHL}	Propagation Delay Time, High-to-Low Level Output					25	
t_{PLH}	Propagation Delay Time, Low-to-High Level Output	A_i or B_i	F_i	$M = 0V$, $S_0 = S_3 = 4.5V$ $S_1 = S_2 = 0V$ (SUM mode)		30	ns
t_{PHL}	Propagation Delay Time, High-to-Low Level Output					30	
t_{PLH}	Propagation Delay Time, Low-to-High Level Output	A_i or B_i	F_i	$M = 0V$, $S_0 = S_3 = 0V$ $S_1 = S_2 = 4.5V$ (DIFF mode)		24	ns
t_{PHL}	Propagation Delay Time, High-to-Low Level Output					24	
t_{PLH}	Propagation Delay Time, Low-to-High Level Output	A_i or B_i	F_i	$M = 4.5V$ (logic mode)		28	ns
t_{PHL}	Propagation Delay Time, High-to-Low Level Output					30	
t_{PLH}	Propagation Delay Time, Low-to-High Level Output	Any A or B	$A = B$	$M = 0V$, $S_0 = S_3 = 0V$ $S_1 = S_2 = 4.5V$ (DIFF mode)		40	ns
t_{PHL}	Propagation Delay Time, High-to-Low Level Output					40	

General Description (Continued)

If high speed is not important, a ripple-carry input (C_n) and a ripple-carry output (C_{n+4}) are available. However, the ripple-carry delay has also been minimized so that arithmetic manipulations for small word lengths can be performed without external circuitry.

These circuits will accommodate active-high or active-low data, if the pin designations are interpreted as shown below.

Subtraction is accomplished by 1's complement addition, where the 1's complement of the subtrahend is generated internally. The resultant output is $A-B-1$, which requires an end-around or forced carry to provide $A-B$.

The 181 can also be utilized as a comparator. The $A = B$ output is internally decoded from the function outputs (F_0, F_1, F_2, F_3) so that when two words of equal magnitude are applied at the A and B inputs, it will assume a high level to indicate equality ($A = B$). The ALU should be in the subtract mode with $C_n = H$ when performing this comparison. The $A = B$ output is open-collector so that it can be wire-AND connected to give a comparison for more than four bits. The carry output (C_{n+4}) can also be used to supply

relative magnitude information. Again, the ALU should be placed in the subtract mode by placing the function select inputs S_3, S_2, S_1, S_0 at L, H, H, L, respectively.

These circuits have been designed to not only incorporate all of the designer's requirements for arithmetic operations, but also to provide 16 possible functions of two Boolean variables without the use of external circuitry. These logic functions are selected by use of the four function-select inputs (S_0, S_1, S_2, S_3) with the mode-control input (M) at a high level to disable the internal carry. The 16 logic functions are detailed in Tables 1 and 2 and include exclusive-OR, NAND, AND, NOR, and OR functions.

ALU SIGNAL DESIGNATIONS

The DM54181 can be used with the signal designations of either *Figure 1* or *Figure 2*.

The logic functions and arithmetic operations obtained with signal designations as in *Figure 1* are given in Table I; those obtained with the signal designations of *Figure 2* are given in Table II.

Pin Number	2	1	23	22	21	20	19	18	9	10	11	13	7	16	15	17
Active-High Data (Table I)	A0	B0	A1	B1	A2	B2	A3	B3	F0	F1	F2	F3	\bar{C}_n	\bar{C}_{n+4}	X	Y
Active-Low Data (Table II)	$\bar{A}0$	$\bar{B}0$	$\bar{A}1$	$\bar{B}1$	$\bar{A}2$	$\bar{B}2$	$\bar{A}3$	$\bar{B}3$	$\bar{F}0$	$\bar{F}1$	$\bar{F}2$	$\bar{F}3$	C_n	C_{n+4}	\bar{P}	\bar{G}

Input C_n	Output C_{n+4}	Active-High Data (Figure 1)	Active-Low Data (Figure 2)
H	H	$A \leq B$	$A \geq B$
H	L	$A > B$	$A < B$
L	H	$A < B$	$A > B$
L	L	$A \geq B$	$A \leq B$

General Description (Continued)

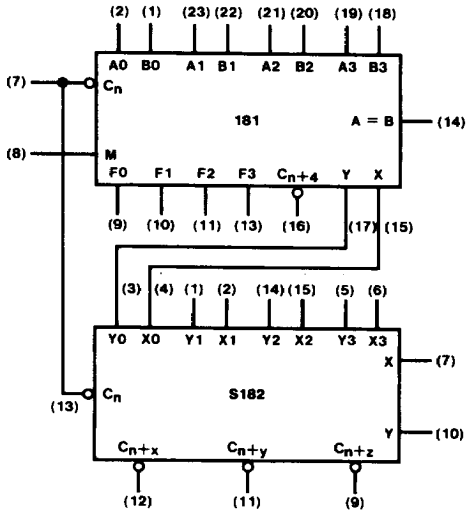

FIGURE 1

TL/F/6560-2

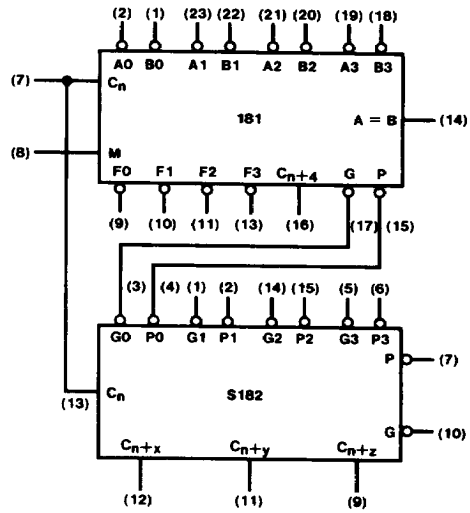

FIGURE 2

TL/F/6560-3

TABLE I

Selection				Active High Data		
				M = H Logic Functions	M = L; Arithmetic Operations	
S3	S2	S1	S0		C _n = H (no carry)	C _n = L (with carry)
L	L	L	L	$F = \bar{A}$	$F = A$	$F = A$ Plus 1
L	L	L	H	$F = \bar{A} + \bar{B}$	$F = A + B$	$F = (A + B)$ Plus 1
L	L	H	L	$F = \bar{A}B$	$F = A + \bar{B}$	$F = (A + \bar{B})$ Plus 1
L	L	H	H	$F = 0$	$F = \text{Minus 1 (2's Compl)}$	$F = \text{Zero}$
L	H	L	L	$F = \bar{A}\bar{B}$	$F = A$ Plus $\bar{A}\bar{B}$	$F = A$ Plus $\bar{A}\bar{B}$ Plus 1
L	H	L	H	$F = \bar{B}$	$F = (A + B)$ Plus $\bar{A}\bar{B}$	$F = (A + B)$ Plus $\bar{A}\bar{B}$ Plus 1
L	H	H	L	$F = A \oplus B$	$F = A$ Minus B Minus 1	$F = A$ Minus B
L	H	H	H	$F = \bar{A}\bar{B}$	$F = \bar{A}\bar{B}$ Minus 1	$F = \bar{A}\bar{B}$
H	L	L	L	$F = \bar{A} + B$	$F = A$ Plus $\bar{A}B$	$F = A$ Plus $\bar{A}B$ Plus 1
H	L	L	H	$F = \bar{A} \oplus \bar{B}$	$F = A$ Plus B	$F = A$ Plus B Plus 1
H	L	H	L	$F = B$	$F = (A + \bar{B})$ Plus $\bar{A}B$	$F = (A + \bar{B})$ Plus $\bar{A}B$ Plus 1
H	L	H	H	$F = \bar{A}B$	$F = \bar{A}B$ Minus 1	$F = \bar{A}B$
H	H	L	L	$F = 1$	$F = A$ Plus A^*	$F = A$ Plus A Plus 1
H	H	L	H	$F = A + \bar{B}$	$F = (A + B)$ Plus A	$F = (A + B)$ Plus A Plus 1
H	H	H	L	$F = A + B$	$F = (A + \bar{B})$ Plus A	$F = (A + \bar{B})$ Plus A Plus 1
H	H	H	H	$F = A$	$F = A$ Minus 1	$F = A$

*Each bit is shifted to the next more significant position.

General Description (Continued)

TABLE II

Selection				Active Low Data		
				M = H Logic Functions	M = L; Arithmetic Operations	
S3	S2	S1	S0		C _n = L (no carry)	C _n = H (with carry)
L	L	L	L	$F = \bar{A}$	F = A Minus 1	F = A
L	L	L	H	$F = \bar{A}\bar{B}$	F = AB Minus 1	F = AB
L	L	H	L	$F = \bar{A} + B$	F = $\bar{A}\bar{B}$ Minus 1	F = $\bar{A}\bar{B}$
L	L	H	H	F = 1	F = Minus 1 (2's Compl)	F = Zero
L	H	L	L	$F = \bar{A} + \bar{B}$	F = A Plus (A + \bar{B})	F = A Plus (A + \bar{B}) Plus 1
L	H	L	H	$F = \bar{B}$	F = AB Plus (A + B)	F = AB Plus (A + \bar{B}) Plus 1
L	H	H	L	$F = \bar{A} \oplus \bar{B}$	F = A Minus B Minus 1	F = A Minus B
L	H	H	H	$F = A + \bar{B}$	F = A + \bar{B}	F = (A + \bar{B}) Plus 1
H	L	L	L	$F = \bar{A}\bar{B}$	F = A Plus (A + B)	F = A Plus (A + B) Plus 1
H	L	L	H	F = A \oplus B	F = A Plus B	F = A Plus B Plus 1
H	L	H	L	F = B	F = $\bar{A}\bar{B}$ Plus (A + B)	F = $\bar{A}\bar{B}$ Plus (A + B) Plus 1
H	L	H	H	F = A + B	F = A + B	F = (A + B) Plus 1
H	H	L	L	F = 0	F = A Plus A*	F = A Plus A Plus 1
H	H	L	H	F = $\bar{A}\bar{B}$	F = AB Plus A	F = AB Plus A Plus 1
H	H	H	L	F = AB	F = $\bar{A}\bar{B}$ Plus A	F = $\bar{A}\bar{B}$ Plus A Plus 1
H	H	H	H	F = A	F = A	F = A Plus 1

*Each bit is shifted to the next more significant position.

Parameter Measurement Information

Logic Mode Test Table

Function Inputs: S1 = S2 = M = 4.5V, S0 = S3 = 0V

Parameter	Input Under Test	Other Input Same Bit		Other Data Inputs		Output Under Test	Output Waveform
		Apply 4.5V	Apply GND	Apply 4.5V	Apply GND		
t _{PLH}	A _i	B _i	None	None	Remaining A and B, C _n	F _i	Out-of-Phase
t _{PHL}							
t _{PLH}	B _i	A _i	None	None	Remaining A and B, C _n	F _i	Out-of-Phase
t _{PHL}							

SUM Mode Test Table

Function Inputs: S0 = S3 = 4.5V, S1 = S2 = M = 0V

Parameter	Input Under Test	Other Input Same Bit		Other Data Inputs		Output Under Test	Output Waveform
		Apply 4.5V	Apply GND	Apply 4.5V	Apply GND		
t _{PLH}	A _i	B _i	None	Remaining A and B	C _n	F _i	In-Phase
t _{PHL}							
t _{PLH}	B _i	A _i	None	Remaining A and B	C _n	F _i	In-Phase
t _{PHL}							
t _{PLH}	A _i	B _i	None	None	Remaining A and B, C _n	P	In-Phase
t _{PHL}							
t _{PLH}	B _i	A _i	None	None	Remaining A and B, C _n	P	In-Phase
t _{PHL}							

Parameter Measurement Information (Continued)

SUM Mode Test Table

Function Inputs: S0 = S3 = 4.5V, S1 = S2 = M = 0V (Continued)

Parameter	Input Under Test	Other Input Same Bit		Other Data Inputs		Output Under Test	Output Waveform
		Apply 4.5V	Apply GND	Apply 4.5V	Apply GND		
t _{PLH}	A _i	None	B _i	Remaining B	Remaining A, C _n	G	In-Phase
t _{PHL}							
t _{PLH}	B _i	None	A _i	Remaining B	Remaining A, C _n	G	In-Phase
t _{PHL}							
t _{PLH}	C _n	None	None	All A	All B	Any F or C _n + 4	In-Phase
t _{PHL}							
t _{PLH}	A _i	None	B _i	Remaining B	Remaining A, C _n	C _n + 4	Out-of-Phase
t _{PHL}							
t _{PLH}	B _i	None	A _i	Remaining B	Remaining A, C _n	C _n + 4	Out-of-Phase
t _{PHL}							

DIFF Mode Test Table

Function Inputs: S1 = S2 = 4.5V, S0 = S3 = M = 0V

Parameter	Input Under Test	Other Input Same Bit		Other Data Inputs		Output Under Test	Output Waveform
		Apply 4.5V	Apply GND	Apply 4.5V	Apply GND		
t _{PLH}	A _i	None	B _i	Remaining A	Remaining B, C _n	F _i	In-Phase
t _{PHL}							
t _{PLH}	B _i	A _i	None	Remaining A	Remaining B, C _n	F _i	Out-of-Phase
t _{PHL}							
t _{PLH}	A _i	None	B _i	None	Remaining A and B, C _n	P	In-Phase
t _{PHL}							
t _{PLH}	B _i	A _i	None	None	Remaining A and B, C _n	P	Out-of-Phase
t _{PHL}							
t _{PLH}	A _i	B _i	None	None	Remaining A and B, C _n	G	In-Phase
t _{PHL}							
t _{PLH}	B _i	None	A _i	None	Remaining A and B, C _n	G	Out-of-Phase
t _{PHL}							
t _{PLH}	A _i	None	B _i	Remaining A	Remaining B, C _n	A = B	In-Phase
t _{PHL}							
t _{PLH}	B _i	A _i	None	Remaining A	Remaining B, C _n	A = B	Out-of-Phase
t _{PHL}							
t _{PLH}	C _n	None	None	All A and B	None	C _n + 4 or any F	In-Phase
t _{PHL}							
t _{PLH}	A _i	B _i	None	None	Remaining A, B, C _n	C _n + 4	Out-of-Phase
t _{PHL}							
t _{PLH}	B _i	None	A _i	None	Remaining A, B, C _n	C _n + 4	In-Phase
t _{PHL}							

Logic Diagram

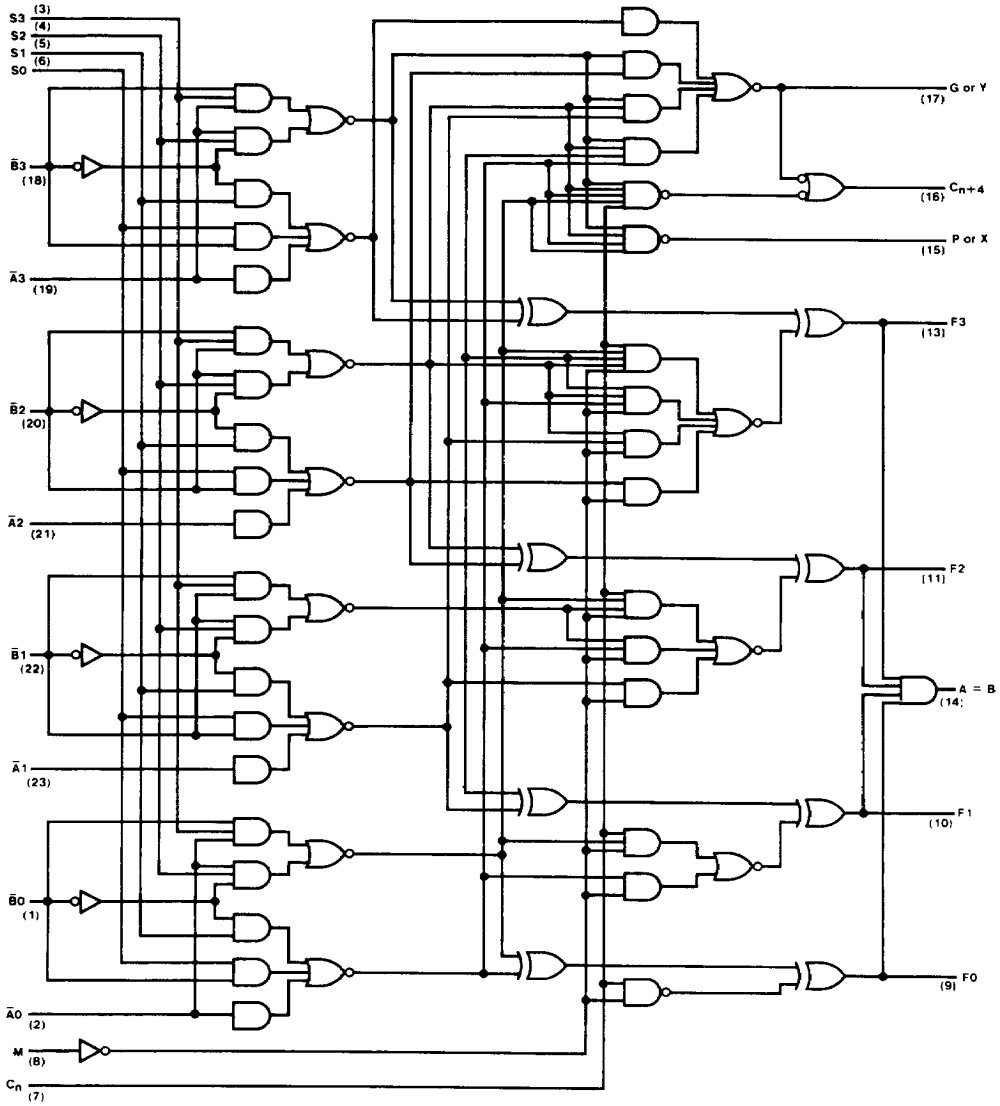

V_{CC} = PIN 24
GND = PIN 12

TL/F/6560-4

This datasheet has been downloaded from:

www.DatasheetCatalog.com

Datasheets for electronic components.

National Semiconductor was acquired by Texas Instruments.

http://www.ti.com/corp/docs/investor_relations/pr_09_23_2011_national_semiconductor.html

This file is the datasheet for the following electronic components:

DM74181N - <http://www.ti.com/product/dm74181n?HQS=TI-null-null-dscatalog-df-pf-null-ww>



LittleDiode supplies new, hard to find or obsolete electronic components and semiconductors all over the world.

With over two million different components listed you are sure to find the part you need.

Feel free to visit us today at our online store:

LittleDiode.com

Looking forward to providing you with the best possible service.