



December 1990

DM74ALS132 Quad 2-Input NAND Gate with Schmitt Trigger Inputs

General Description

This device contains four independent gates, each of which performs the logic NAND function. Each input has hysteresis which increases the noise immunity and transforms a slowly changing input signal to a fast changing, jitter-free output.

Features

- Input Hysteresis
- Low output noise generation
- High input noise immunity

- Switching specification at 50 pF
- Switching specifications guaranteed over full temperature and V_{CC} range
- Advanced oxide-isolated, ion-implanted Schottky TTL process
- Functionally and pin-for-pin compatible with Schottky and Low Power Schottky TTL counterparts
- Improved AC performance over low power Schottky counterpart

Connection Diagram

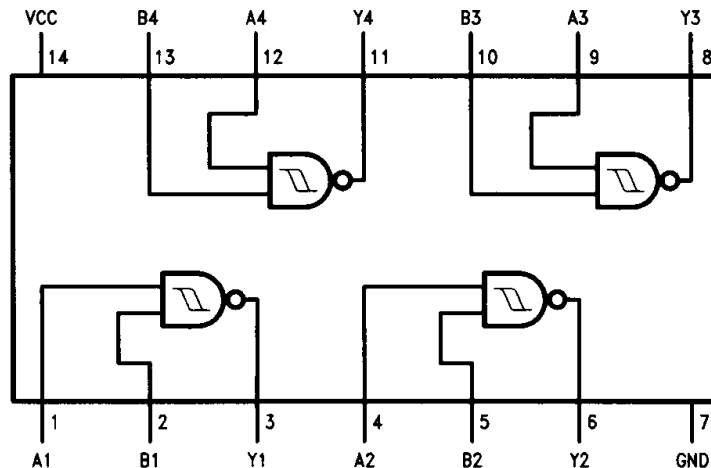

TL/F/8771-1

Order Number DM74ALS132M or DM74ALS132N
See NS Package Number M14A or N14A

Function Table

$$Y = \overline{AB}$$

Inputs		Output Y
A	B	
L	L	H
L	H	H
H	L	H
H	H	L

H = High Logic Level

L = Low Logic Level

DM74ALS132 Quad 2-Input NAND Gate with Schmitt Trigger Inputs

Absolute Maximum Ratings

Supply Voltage	7V
Input Voltage	7V
Operating Free Air Temperature Range DM74ALS	0°C to +70°C
Typical θ_{JA}	
N Package	78.5°C/W
M Package	109.0°C/W

Storage Temperature Range –65°C to +150°C

Note: The "Absolute Maximum Ratings" are those values beyond which the safety of the device can not be guaranteed. The device should not be operated at these limits. The parametric values defined in the "Electrical Characteristics" table are not guaranteed at the absolute maximum ratings. The "Recommended Operating Conditions" table will define the conditions for actual device operation.

Recommended Operating Conditions

Symbol	Parameter	Min	Nom	Max	Units
V_{CC}	Supply Voltage	4.5	5	5.5	V
V_{T+}	Positive-Going Input Threshold Voltage	$V_{CC} = \text{Min to Max}$	1.4	2	V
		$V_{CC} = 5V$	1.55	1.85	
V_{T-}	Negative-Going Input Threshold Voltage	$V_{CC} = \text{Min to Max}$	0.75	1.2	V
		$V_{CC} = 5V$	0.85	1.1	
HYS	Input Hysteresis	$V_{CC} = \text{Min to Max}$	0.5		V
		$V_{CC} = 5V$	0.6		
I_{OH}	High Level Output Current			-0.4	mA
I_{OL}	Low Level Output Current			8	mA
T_A	Operating Free Air Temperature Range	0		70	°C

Electrical Characteristics over recommended free air temperature range

Symbol	Parameter	Test Conditions	Min	Typ	Max	Units
V_K	Input Clamp Voltage	$V_{CC} = \text{Min}, I_I = -18 \text{ mA}$			-1.5	V
V_{OH}	High Level Output Voltage	$V_{CC} = 4.5V \text{ to } 5.5V, I_{OH} = \text{Max}$	$V_{CC} - 2$			V
V_{OL}	Low Level Output Voltage	$V_{CC} = \text{Min}$	$I_{OL} = 4 \text{ mA}$	0.25	0.4	V
			$I_{OL} = 8 \text{ mA}$		0.35	
I_{T+}	Input Current at Positive-Going Threshold Voltage	$V_{CC} = 5V, V_I = V_{T+}$			20	μA
I_{T-}	Input Current at Negative-Going Threshold Voltage	$V_{CC} = 5V, V_I = V_{T-}$			-100	μA
I_I	Input Current at Maximum Input Voltage	$V_{CC} = \text{Max}, V_I = 7V$			100	μA
I_{IH}	High Level Input Current	$V_{CC} = \text{Max}, V_I = 2.7V$			20	μA
I_{IL}	Low Level Input Current	$V_{CC} = \text{Max}, V_I = 0.4V$			-100	μA
I_O	Output Drive Current	$V_{CC} = \text{Max}, V_O = 2.25V$	-30		-112	mA
I_{CCH}	Supply Current with Outputs High	$V_{CC} = \text{Max}$			8	mA
I_{CCL}	Supply Current with Outputs Low	$V_{CC} = \text{Max}$			8	mA
V_{OLP}	Quiet Output Maximum Dynamic V_{OL}	$V_{CC} = 5.0V, T_A = 25^\circ\text{C}$ (Figures 1, 2; Notes 1, 2)		0.159		V
V_{OLV}	Quiet Output Minimum Dynamic V_{OL}	$V_{CC} = 5.0V, T_A = 25^\circ\text{C}$ (Figures 1, 2; Notes 1, 2)		-0.096		V
V_{IHD}	Minimum High Level Dynamic Input Voltage	$V_{CC} = 5.0V, T_A = 25^\circ\text{C}$ (Notes 1, 3)		0.96		V
V_{ILD}	Maximum Low Level Dynamic Input Voltage	$V_{CC} = 5.0V, T_A = 25^\circ\text{C}$ (Notes 1, 3)		1.54		V

Note 1: Plastic DIP package.

Note 2: n = number of device outputs; n - 1 outputs switching, each driven 0V to 3V one output @ GND.

Note 3: n = number of device outputs; n outputs switching, n - 1 outputs switching 0V to 3V. Input under test switching 3V to threshold (V_{ILD}); 0V to threshold (V_{IHD}); f = 1 MHz.

Switching Characteristics over recommended operating free air temperature range

Symbol	Parameter	Conditions (Note 1)	Min	Max	Units
t_{PLH}	Propagation Delay Time Low to High Level Output	$V_{CC} = 4.5V$ to $5.5V$ $RL = 500\Omega$, $CL = 50$ pF	2	12	ns
t_{PHL}	Propagation Delay Time High to Low Level Output		2	11	

Note 1: See Section 1 for test waveforms and output load.

ALS Noise Characteristics

The setup of a noise characteristics measurement is critical to the accuracy and repeatability of the tests. The following is a brief description of the setup used to measure the noise characteristics of ALS.

Equipment:

- Word Generator
- Printed Circuit Board Test Fixture
- Dual Trace Oscilloscope

Procedure:

1. Verify Test Fixture Loading: Standard Load 50 pF, 500 Ω .
2. Deskew the word generator so that no two channels have greater than 150 ps skew between them. This requires that the oscilloscope be deskewed first. Swap out the channels that have more than 150 ps of skew until all channels being used are within 150 ps. It is important to deskew the word generator channels before testing. This will ensure that the outputs switch simultaneously.
3. Terminate all inputs and outputs to ensure proper loading of the outputs and that the input levels are at the correct voltage.
4. Set V_{CC} to 5.0V.
5. Set the word generator to toggle all but one output at a frequency of 1 MHz. Greater frequencies will increase DUT heating and affect the results of the measurement.

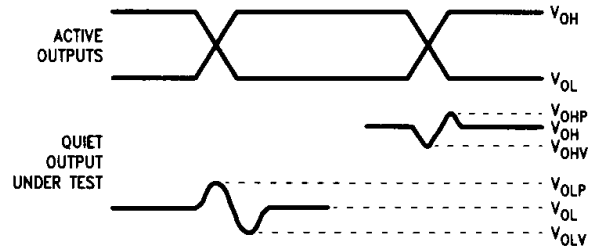

TL/F/8771-2

FIGURE 1. Quiet Output Noise Voltage Waveforms

Note A. V_{OHP} and V_{OHV} are measured with respect to V_{OH} reference. V_{OLV} and V_{OLP} are measured with respect to ground reference.

Note B. Input pulses have the following characteristics: $f = 1$ MHz, $t_r = 3$ ns, $t_f = 3$ ns, skew < 150 ps.

6. Set the word generator input levels at 0V LOW and 3V HIGH. Verify levels with a digital volt meter.

V_{OLP}/V_{OLV} and V_{OHP}/V_{OHV} :

- Determine the quiet output pin that demonstrates the greatest noise levels. The worst case pin will usually be the furthest from the ground pin. Monitor the output voltages using a 50 Ω coaxial cable plugged into a standard SMB type connector on the test fixture. Do not use an active FET probe.
- Verify that the GND reference recorded on the oscilloscope has not drifted to ensure the accuracy and repeatability of the measurements.

ALS Noise Characteristics (Continued)

V_{ILD} and V_{IHD} :

- Monitor one of the switching outputs using a 50 Ω coaxial cable plugged into a standard SMB type connector on the test fixture. Do not use an active FET probe.
- First increase the input LOW voltage level, V_{IL} , until the output begins to oscillate. Oscillation is defined as noise on the output LOW level that exceeds V_{IL} limits, or on output HIGH levels that exceed V_{IH} limits. The input LOW voltage level at which oscillation occurs is defined as V_{ILD} .
- Next decrease the input HIGH voltage level on the word generator, V_{IH} until the output begins to oscillate. Oscillation is defined as noise on the output LOW level that exceeds V_{IL} limits, or on output HIGH levels that exceed V_{IH} limits. The input HIGH voltage level at which oscillation occurs is defined as V_{IHD} .
- Verify that the GND reference recorded on the oscilloscope has not drifted to ensure the accuracy and repeatability of the measurements.

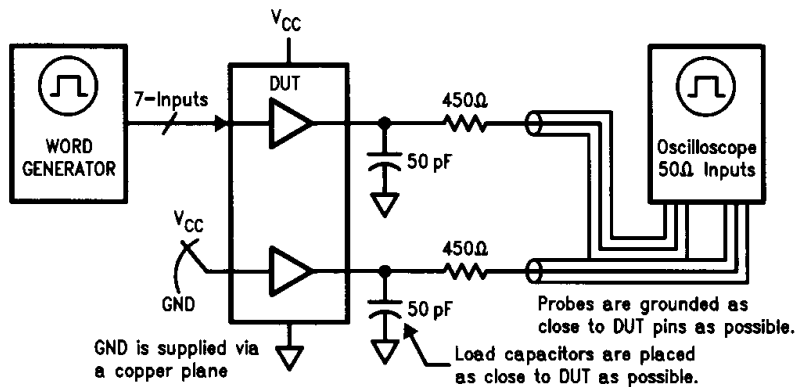
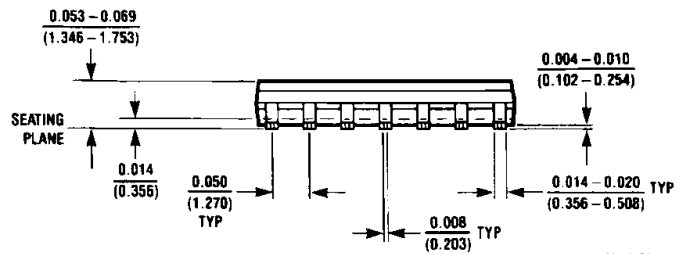
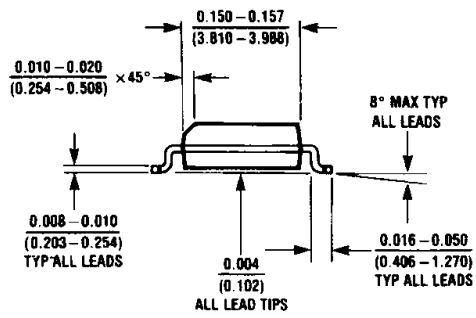
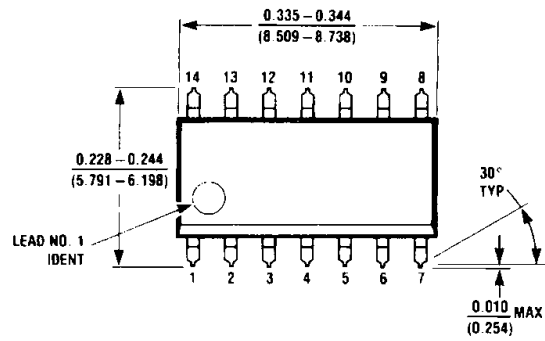

FIGURE 2. Simultaneous Switching Test Circuit

TL/F/8771-3

Physical Dimensions inches (millimeters)



M14A (REV H)

S.O. Package (M)
Order Number DM74ALS132M
NS Package Number M14A

Physical Dimensions inches (millimeters) (Continued)

Lit # 102550

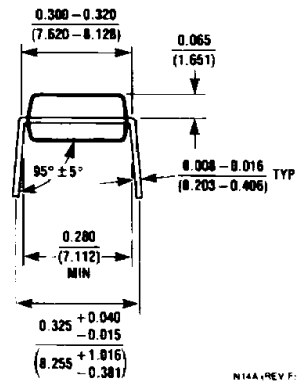
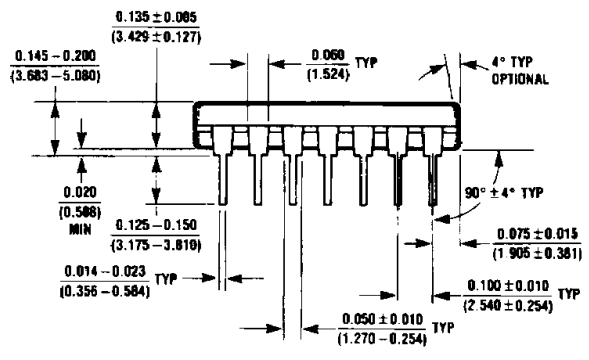
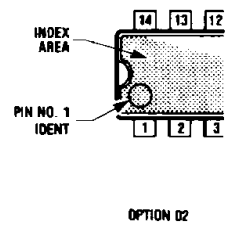
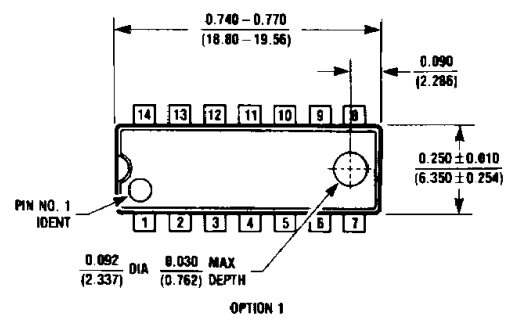

**Molded Dual-In-Line Package (N)
Order Number DM74ALS132N
NS Package Number N14A**

N14A, REV. F.

LIFE SUPPORT POLICY

NATIONAL'S PRODUCTS ARE NOT AUTHORIZED FOR USE AS CRITICAL COMPONENTS IN LIFE SUPPORT DEVICES OR SYSTEMS WITHOUT THE EXPRESS WRITTEN APPROVAL OF THE PRESIDENT OF NATIONAL SEMICONDUCTOR CORPORATION. As used herein:

1. Life support devices or systems are devices or systems which, (a) are intended for surgical implant into the body, or (b) support or sustain life, and whose failure to perform, when properly used in accordance with instructions for use provided in the labeling, can be reasonably expected to result in a significant injury to the user.
2. A critical component is any component of a life support device or system whose failure to perform can be reasonably expected to cause the failure of the life support device or system, or to affect its safety or effectiveness.

APR 15 1991

[Signature]

 <p>National Semiconductor Corporation 2900 Semiconductor Drive P.O. Box 58090 Santa Clara, CA 95052-8090 Tel: (800) 272-9959 TWX: (910) 339-9240</p>	<p>National Semiconductor GmbH Industriestrasse 10 D-8080 Furstenfeldbruck West Germany Tel: (0-81-41) 103-0 Telex: 527-649 Fax: (08141) 103554</p>	<p>National Semiconductor Japan Ltd. Sanseido Bldg, 5F 4-15 Nishi Shinjuku Shinjuku-Ku, Tokyo 160, Japan Tel: 3-299-7001 FAX: 3-299-7000</p>	<p>National Semiconductor Hong Kong Ltd. Suite 513, 5th Floor Chinachem Golden Plaza, 77 Mody Road, Tsimshatsui East, Kowloon, Hong Kong Tel: 3-7231290 Telex: 52996 NSSEA HX Fax: 3-3112536</p>	<p>National Semicondutores Do Brasil Ltda. Av. Brig. Faria Lima, 1383 6.0 Andor-Conj. 62 01451 Sao Paulo, SP, Brasil Tel: (55/11) 212-5066 Fax: (55/11) 211-1181 NSBR BR</p>	<p>National Semiconductor (Australia) PTY, Ltd. 1st Floor, 441 St. Kilda Rd. Melbourne, 3004 Victoria, Australia Tel: (03) 267-5000 Fax: 61-3-2677458</p>
---	--	---	---	---	--

This datasheet has been downloaded from:

www.DatasheetCatalog.com

Datasheets for electronic components.

National Semiconductor was acquired by Texas Instruments.

http://www.ti.com/corp/docs/investor_relations/pr_09_23_2011_national_semiconductor.html

This file is the datasheet for the following electronic components:

DM74ALS132 - <http://www.ti.com/product/dm74als132?HQS=TI-null-null-dscatalog-df-pf-null-wwe>

DM74ALS132M - <http://www.ti.com/product/dm74als132m?HQS=TI-null-null-dscatalog-df-pf-null-wwe>

DM74ALS132N - <http://www.ti.com/product/dm74als132n?HQS=TI-null-null-dscatalog-df-pf-null-wwe>



LittleDiode supplies new, hard to find or obsolete electronic components and semiconductors all over the world.

With over two million different components listed you are sure to find the part you need.

Feel free to visit us today at our online store:

LittleDiode.com

Looking forward to providing you with the best possible service.