

DM74LS161A • DM74LS163A Synchronous 4-Bit Binary Counters

General Description

These synchronous, presettable counters feature an internal carry look-ahead for application in high-speed counting designs. The DM74LS161A and DM74LS163A are 4-bit binary counters. The carry output is decoded by means of a NOR gate, thus preventing spikes during the normal counting mode of operation. Synchronous operation is provided by having all flip-flops clocked simultaneously so that the outputs change coincident with each other when so instructed by the count-enable inputs and internal gating. This mode of operation eliminates the output counting spikes which are normally associated with asynchronous (ripple clock) counters. A buffered clock input triggers the four flip-flops on the rising (positive-going) edge of the clock input waveform.

These counters are fully programmable; that is, the outputs may be preset to either level. As presetting is synchronous, setting up a low level at the load input disables the counter and causes the outputs to agree with the setup data after the next clock pulse, regardless of the levels of the enable input. The clear function for the DM74LS161A is asynchronous; and a low level at the clear input sets all four of the flip-flop outputs LOW, regardless of the levels of clock, load, or enable inputs. The clear function for the DM74LS163A is synchronous; and a low level at the clear inputs sets all four of the flip-flop outputs LOW after the next clock pulse, regardless of the levels of the enable inputs. This synchronous clear allows the count length to be modified easily, as decoding the maximum count desired can be accomplished with one external NAND gate. The gate output is connected to the clear input to synchronously clear the counter to all low outputs.

The carry look-ahead circuitry provides for cascading counters for n-bit synchronous applications without additional gating. Instrumental in accomplishing this function are two count-enable inputs and a ripple carry output.

Both count-enable inputs (P and T) must be HIGH to count, and input T is fed forward to enable the ripple carry output. The ripple carry output thus enabled will produce a high-level output pulse with a duration approximately equal to the high-level portion of the Q_A output. This high-level overflow ripple carry pulse can be used to enable successive cascaded stages. HIGH-to-LOW level transitions at the enable P or T inputs may occur, regardless of the logic level of the clock.

These counters feature a fully independent clock circuit. Changes made to control inputs (enable P or T or load) that will modify the operating mode have no effect until clocking occurs. The function of the counter (whether enabled, disabled, loading, or counting) will be dictated solely by the conditions meeting the stable set-up and hold times.

Features

- Synchronously programmable
- Internal look-ahead for fast counting
- Carry output for n-bit cascading
- Synchronous counting
- Load control line
- Diode-clamped inputs
- Typical propagation time, clock to Q output 14 ns
- Typical clock frequency 32 MHz
- Typical power dissipation 93 mW

Ordering Code:

Order Number	Package Number	Package Description
DM74LS161AM	M16A	16-Lead Small Outline Integrated Circuit (SOIC), JEDEC MS-012, 0.150 Narrow
DM74LS161AN	N16E	16-Lead Plastic Dual-In-Line Package (PDIP), JEDEC MS-001, 0.300 Wide
DM74LS163AM	M16A	16-Lead Small Outline Integrated Circuit (SOIC), JEDEC MS-012, 0.150 Narrow
DM74LS163AN	N16E	16-Lead Plastic Dual-In-Line Package (PDIP), JEDEC MS-001, 0.300 Wide

Devices also available in Tape and Reel. Specify by appending the suffix letter "X" to the ordering code.

Connection Diagram

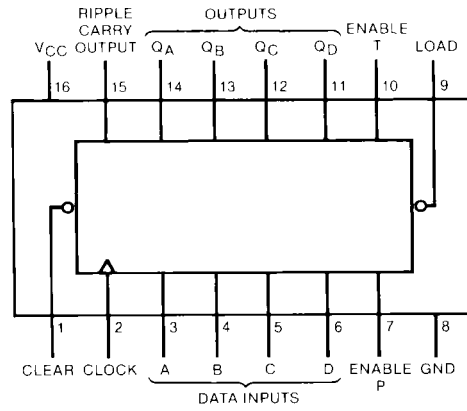

Logic Diagram

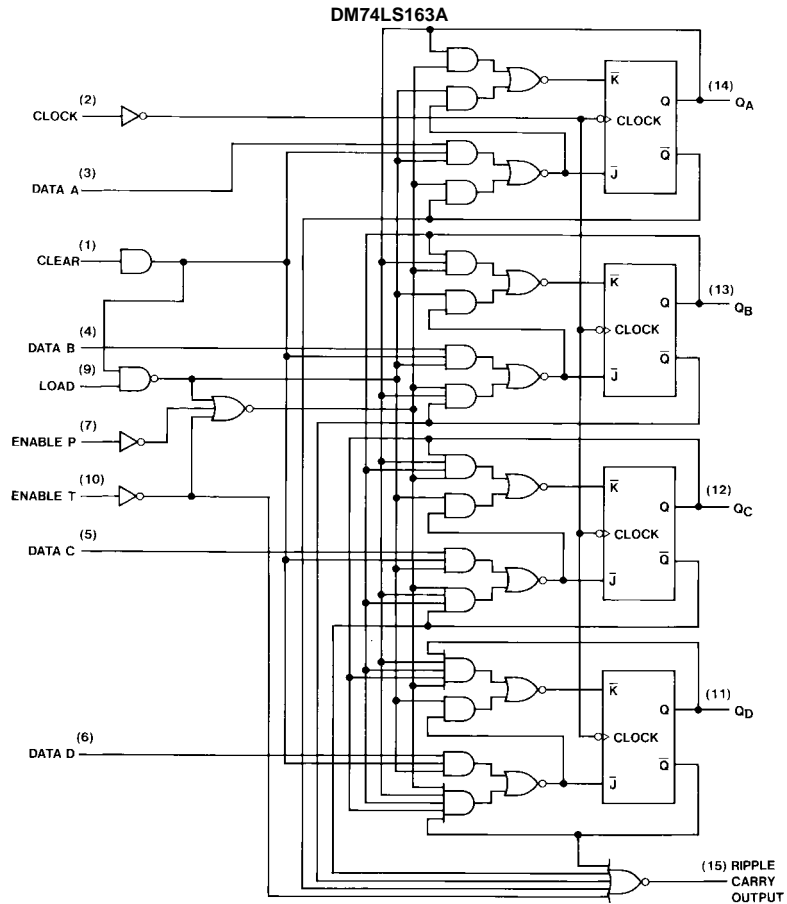

The DM74LS161A is similar, however, the clear buffer is connected directly to the flip-flops.

Parameter Measurement Information

Switching Time Waveforms

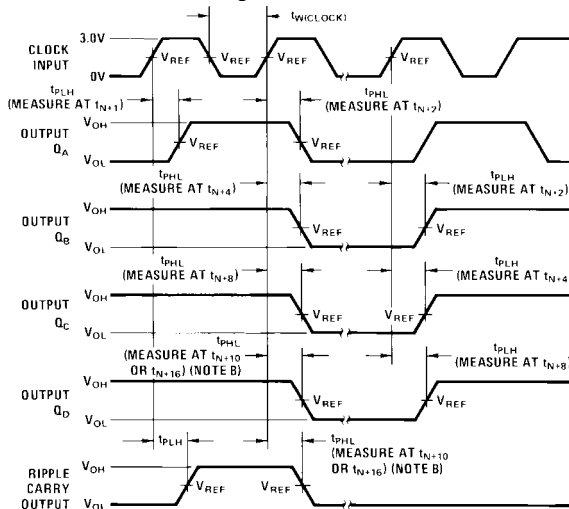

The input pulses are supplied by generators having the following characteristics:
 PRR \leq 1 MHz, duty cycle \leq 50%, $Z_{OUT} = 50\Omega$, $t_r \leq 10$ ns, $t_f \leq 10$ ns.

Vary PRR to measure f_{MAX} .

Outputs Q_D and carry are tested at t_{N+16} where t_N is the bit time when all outputs are LOW.

$V_{REF} = 1.5V$.

Switching Time Waveforms

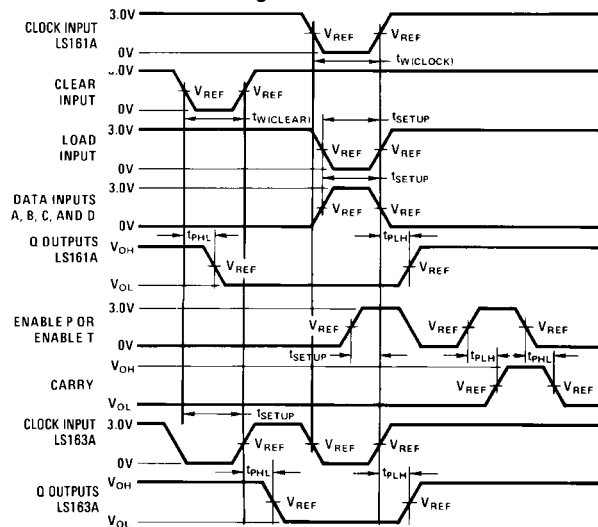

The input pulses are supplied by generators having the following characteristics:
 PRR \leq 1 MHz, duty cycle \leq 50%, $Z_{OUT} = 50\Omega$, $t_r \leq 6$ ns, $t_f \leq 6$ ns. Vary PRR to measure f_{MAX} .

Enable P and enable T setup times are measured at t_{N+0} .

$V_{REF} = 1.3V$.

Timing Diagram

LS161A, LS163A Synchronous Binary Counters
Typical Clear, Preset, Count and Inhibit Sequences

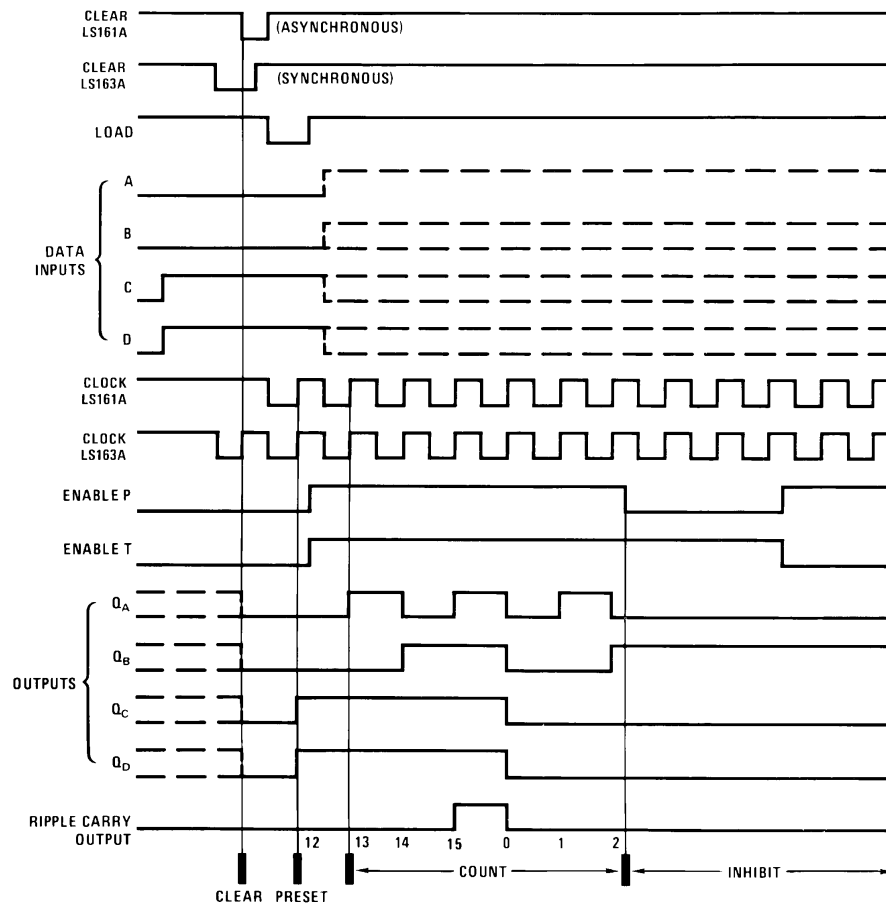

Sequence:

- (1) Clear outputs to zero
- (2) Preset to binary twelve
- (3) Count to thirteen, fourteen, fifteen, zero, one, and two
- (4) Inhibit

Absolute Maximum Ratings(Note 1)

Supply Voltage	7V
Input Voltage	7V
Operating Free Air Temperature Range	0°C to +70°C
Storage Temperature Range	-65°C to +150°C

Note 1: The "Absolute Maximum Ratings" are those values beyond which the safety of the device cannot be guaranteed. The device should not be operated at these limits. The parametric values defined in the Electrical Characteristics tables are not guaranteed at the absolute maximum ratings. The "Recommended Operating Conditions" table will define the conditions for actual device operation.

DM74LS161A Recommended Operating Conditions

Symbol	Parameter	Min	Nom	Max	Units
V _{CC}	Supply Voltage	4.75	5	5.25	V
V _{IH}	HIGH Level Input Voltage	2			V
V _{IL}	LOW Level Input Voltage			0.8	V
I _{OH}	HIGH Level Output Current			-0.4	mA
I _{OL}	LOW Level Output Current			8	mA
f _{CLK}	Clock Frequency (Note 2)	0		25	MHz
	Clock Frequency (Note 3)	0		20	MHz
t _w	Pulse Width (Note 2)	Clock	20	6	ns
		Clear	20	9	
	Pulse Width (Note 3)	Clock	25		ns
		Clear	25		
t _{SU}	Setup Time (Note 2)	Data	20	8	ns
		Enable P	25	17	
		Load	25	15	
	Setup Time (Note 3)	Data	20		ns
		Enable P	30		
		Load	30		
t _H	Hold Time (Note 2)	Data	0	-3	ns
		Others	0	-3	
	Hold Time (Note 3)	Data	5		ns
		Others	5		
t _{REL}	Clear Release Time (Note 2)	20			ns
	Clear Release Time (Note 3)	25			ns
T _A	Free Air Operating Temperature	0		70	°C

Note 2: C_L = 15 pF, R_L = 2 kΩ, T_A = 25°C and V_{CC} = 5.5V.

Note 3: C_L = 50 pF, R_L = 2 kΩ, T_A = 25°C and V_{CC} = 5.5V.

DM74LS161A Electrical Characteristics

over recommended operating free air temperature range (unless otherwise noted)

Symbol	Parameter	Conditions	Min	Typ (Note 4)	Max	Units
V_I	Input Clamp Voltage	$V_{CC} = \text{Min}$, $I_I = -18 \text{ mA}$			-1.5	V
V_{OH}	HIGH Level Output Voltage	$V_{CC} = \text{Min}$, $I_{OH} = \text{Max}$ $V_{IL} = \text{Max}$, $V_{IH} = \text{Min}$	2.7	3.4		V
V_{OL}	LOW Level Output Voltage	$V_{CC} = \text{Min}$, $I_{OL} = \text{Max}$ $V_{IL} = \text{Max}$, $V_{IH} = \text{Min}$ $I_{OL} = 4 \text{ mA}$, $V_{CC} = \text{Min}$		0.35 0.25	0.5 0.4	V
I_I	Input Current @ Max Input Voltage	$V_{CC} = \text{Max}$ $V_I = 7V$			0.2 0.2 0.2 0.1	mA
I_{IH}	HIGH Level Input Current	$V_{CC} = \text{Max}$ $V_I = 2.7V$			40 40 40 20	μA
I_{IL}	LOW Level Input Current	$V_{CC} = \text{Max}$ $V_I = 0.4V$			-0.8 -0.8 -0.8 -0.4	mA
I_{OS}	Short Circuit Output Current	$V_{CC} = \text{Max}$ (Note 5)	-20		-100	mA
I_{CCH}	Supply Current with Outputs HIGH	$V_{CC} = \text{Max}$ (Note 6)		18	31	mA
I_{CCL}	Supply Current with Outputs LOW	$V_{CC} = \text{Max}$ (Note 7)		19	32	mA

Note 4: All typicals are at $V_{CC} = 5V$, $T_A = 25^\circ\text{C}$.

Note 5: Not more than one output should be shorted at a time, and the duration should not exceed one second.

Note 6: I_{CCH} is measured with the load HIGH, then again with the load LOW, with all other inputs HIGH and all outputs OPEN.

Note 7: I_{CCL} is measured with the clock input HIGH, then again with the clock input LOW, with all other inputs LOW and all outputs OPEN.

DM74LS161A Switching Characteristics

at $V_{CC} = 5V$ and $T_A = 25^\circ\text{C}$

Symbol	Parameter	From (Input) To (Output)	$R_L = 2 \text{ k}\Omega$				Units
			$C_L = 15 \text{ pF}$		$C_L = 50 \text{ pF}$		
			Min	Max	Min	Max	
f_{MAX}	Maximum Clock Frequency		25		20		MHz
t_{PLH}	Propagation Delay Time LOW-to-HIGH Level Output	Clock to Ripple Carry		25		30	ns
t_{PHL}	Propagation Delay Time HIGH-to-LOW Level Output	Clock to Ripple Carry		30		38	ns
t_{PLH}	Propagation Delay Time LOW-to-HIGH Level Output	Clock to Any Q (Load HIGH)		22		27	ns
t_{PHL}	Propagation Delay Time HIGH-to-LOW Level Output	Clock to Any Q (Load HIGH)		27		38	ns
t_{PLH}	Propagation Delay Time LOW-to-HIGH Level Output	Clock to Any Q (Load LOW)		24		30	ns
t_{PHL}	Propagation Delay Time HIGH-to-LOW Level Output	Clock to Any Q (Load LOW)		27		38	ns
t_{PLH}	Propagation Delay Time LOW-to-HIGH Level Output	Enable T to Ripple Carry		14		27	ns
t_{PHL}	Propagation Delay Time HIGH-to-LOW Level Output	Enable T to Ripple Carry		15		27	ns
t_{PHL}	Propagation Delay Time HIGH-to-LOW Level Output	Clear to Any Q		28		45	ns

DM74LS163A Recommended Operating Conditions

Symbol	Parameter	Min	Nom	Max	Units
V_{CC}	Supply Voltage	4.75	5	5.25	V
V_{IH}	HIGH Level Input Voltage	2			V
V_{IL}	LOW Level Input Voltage			0.8	V
I_{OH}	HIGH Level Output Current			-0.4	mA
I_{OL}	LOW Level Output Current			8	mA
f_{CLK}	Clock Frequency (Note 8)	0		25	MHz
	Clock Frequency (Note 9)	0		20	MHz
t_W	Pulse Width (Note 8)	Clock	20	6	ns
		Clear	20	9	
	Pulse Width (Note 9)	Clock	25		ns
		Clear	25		
t_{SU}	Setup Time (Note 8)	Data	20	8	ns
		Enable P	25	17	
		Load	25	15	
	Setup Time (Note 9)	Data	20		ns
		Enable P	30		
		Load	30		
t_H	Hold Time (Note 8)	Data	0	-3	ns
		Others	0	-3	
	Hold Time (Note 9)	Data	5		ns
		Others	5		
t_{REL}	Clear Release Time (Note 8)	20			ns
	Clear Release Time (Note 9)	25			ns
T_A	Free Air Operating Temperature	0		70	°C

Note 8: $C_L = 15$ pF, $R_L = 2$ k Ω , $T_A = 25^\circ\text{C}$ and $V_{CC} = 5\text{V}$.

Note 9: $C_L = 50$ pF, $R_L = 2$ k Ω , $T_A = 25^\circ\text{C}$ and $V_{CC} = 5\text{V}$.

DM74LS163A Electrical Characteristics

over recommended operating free air temperature range (unless otherwise noted)

Symbol	Parameter	Conditions	Min	Typ (Note 10)	Max	Units
V_I	Input Clamp Voltage	$V_{CC} = \text{Min}$, $I_I = -18$ mA			-1.5	V
V_{OH}	HIGH Level Output Voltage	$V_{CC} = \text{Min}$, $I_{OH} = \text{Max}$ $V_{IL} = \text{Max}$, $V_{IH} = \text{Min}$	2.7	3.4		V
V_{OL}	LOW Level Output Voltage	$V_{CC} = \text{Min}$, $I_{OL} = \text{Max}$ $V_{IL} = \text{Max}$, $V_{IH} = \text{Min}$		0.35	0.5	V
		$I_{OL} = 4$ mA, $V_{CC} = \text{Min}$		0.25	0.4	
I_I	Input Current @ Max Input Voltage	$V_{CC} = \text{Max}$ $V_I = 7\text{V}$	Enable T		0.2	mA
			Clock, Clear		0.2	
			Load		0.2	
			Others		0.1	
I_{IH}	HIGH Level Input Current	$V_{CC} = \text{Max}$ $V_I = 2.7\text{V}$	Enable T		40	μA
			Load		40	
			Clock, Clear		40	
			Others		20	
I_{IL}	LOW Level Input Current	$V_{CC} = \text{Max}$ $V_I = 0.4\text{V}$	Enable T		-0.8	mA
			Clock, Clear		-0.8	
			Load		-0.8	
			Others		-0.4	
I_{OS}	Short Circuit Output Current	$V_{CC} = \text{Max}$ (Note 11)	-20		-100	mA
I_{CCH}	Supply Current with Outputs HIGH	$V_{CC} = \text{Max}$ (Note 12)		18	31	mA
I_{CCL}	Supply Current with Outputs LOW	$V_{CC} = \text{Max}$ (Note 13)		18	32	mA

Note 10: All typicals are at $V_{CC} = 5\text{V}$, $T_A = 25^\circ\text{C}$.

Note 11: Not more than one output should be shorted at a time, and the duration should not exceed one second.

Note 12: I_{CCH} is measured with the load HIGH, then again with the load LOW, with all other inputs HIGH and all outputs OPEN.

Note 13: I_{CCL} is measured with the clock input HIGH, then again with the clock input LOW, with all other inputs LOW and all outputs OPEN.

DM74LS163A Switching Characteristics

at $V_{CC} = 5V$ and $T_A = 25^\circ C$

Symbol	Parameter	From (Input) To (Output)	$R_L = 2\text{ k}\Omega$				Units
			$C_L = 15\text{ pF}$		$C_L = 50\text{ pF}$		
			Min	Max	Min	Max	
f_{MAX}	Maximum Clock Frequency		25		20		MHz
t_{PLH}	Propagation Delay Time LOW-to-HIGH Level Output	Clock to Ripple Carry		25		30	ns
t_{PHL}	Propagation Delay Time HIGH-to-LOW Level Output	Clock to Ripple Carry		30		38	ns
t_{PLH}	Propagation Delay Time LOW-to-HIGH Level Output	Clock to Any Q (Load HIGH)		22		27	ns
t_{PHL}	Propagation Delay Time HIGH-to-LOW Level Output	Clock to Any Q (Load HIGH)		27		38	ns
t_{PLH}	Propagation Delay Time LOW-to-HIGH Level Output	Clock to Any Q (Load LOW)		24		30	ns
t_{PHL}	Propagation Delay Time HIGH-to-LOW Level Output	Clock to Any Q (Load LOW)		27		38	ns
t_{PLH}	Propagation Delay Time LOW-to-HIGH Level Output	Enable T to Ripple Carry		14		27	ns
t_{PHL}	Propagation Delay Time HIGH-to-LOW Level Output	Enable T to Ripple Carry		15		27	ns
t_{PHL}	Propagation Delay Time HIGH-to-LOW Level Output	Clear to Any Q (Note 14)		28		45	ns

Note 14: The propagation delay clear to output is measured from the clock input transition.

Physical Dimensions inches (millimeters) unless otherwise noted

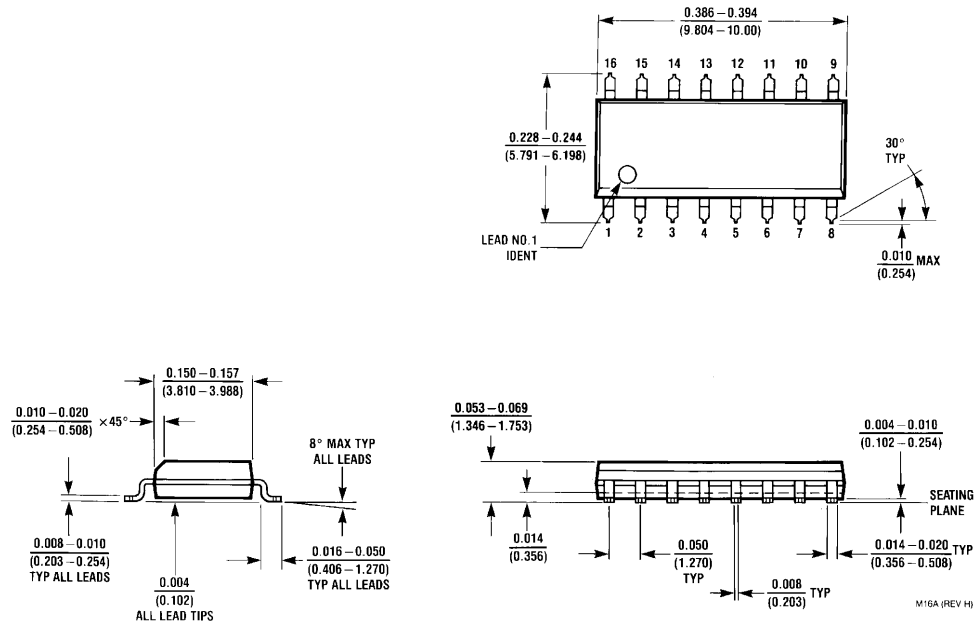

**16-Lead Small Outline Integrated Circuit (SOIC), JEDEC MS-012, 0.150 Narrow
Package Number M16A**

Physical Dimensions inches (millimeters) unless otherwise noted (Continued)

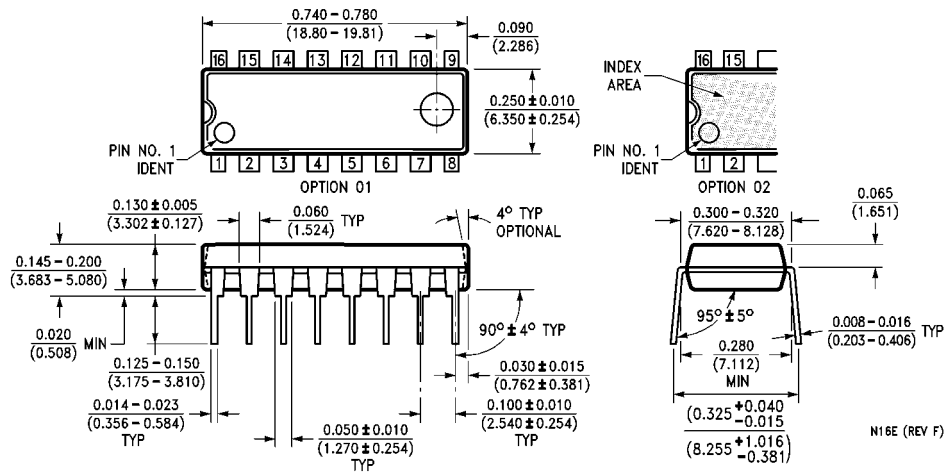

16-Lead Plastic Dual-In-Line Package (PDIP), JEDEC MS-001, 0.300 Wide Package Number N16E

Fairchild does not assume any responsibility for use of any circuitry described, no circuit patent licenses are implied and Fairchild reserves the right at any time without notice to change said circuitry and specifications.

LIFE SUPPORT POLICY

FAIRCHILD'S PRODUCTS ARE NOT AUTHORIZED FOR USE AS CRITICAL COMPONENTS IN LIFE SUPPORT DEVICES OR SYSTEMS WITHOUT THE EXPRESS WRITTEN APPROVAL OF THE PRESIDENT OF FAIRCHILD SEMICONDUCTOR CORPORATION. As used herein:

1. Life support devices or systems are devices or systems which, (a) are intended for surgical implant into the body, or (b) support or sustain life, and (c) whose failure to perform when properly used in accordance with instructions for use provided in the labeling, can be reasonably expected to result in a significant injury to the user.
2. A critical component in any component of a life support device or system whose failure to perform can be reasonably expected to cause the failure of the life support device or system, or to affect its safety or effectiveness.

www.fairchildsemi.com

This datasheet has been downloaded from:

www.DatasheetCatalog.com

Datasheets for electronic components.



LittleDiode supplies new, hard to find or obsolete electronic components and semiconductors all over the world.

With over two million different components listed you are sure to find the part you need.

Feel free to visit us today at our online store:

LittleDiode.com

Looking forward to providing you with the best possible service.