

DS75176B/DS75176BT

Multipoint RS-485/RS-422 Transceivers

General Description

The DS75176B is a high speed differential TRI-STATE® bus/line transceiver designed to meet the requirements of EIA standard RS485 with extended common mode range (+12V to -7V), for multipoint data transmission. In addition, it is compatible with RS-422.

The driver and receiver outputs feature TRI-STATE capability, for the driver outputs over the entire common mode range of +12V to -7V. Bus contention or fault situations that cause excessive power dissipation within the device are handled by a thermal shutdown circuit, which forces the driver outputs into the high impedance state.

DC specifications are guaranteed over the 0 to 70°C temperature and 4.75V to 5.25V supply voltage range.

Features

- Meets EIA standard RS485 for multipoint bus transmission and is compatible with RS-422.
- Small Outline (SO) Package option available for minimum board space.
- 22 ns driver propagation delays.
- Single +5V supply.
- -7V to +12V bus common mode range permits ±7V ground difference between devices on the bus.
- Thermal shutdown protection.
- High impedance to bus with driver in TRI-STATE or with power off, over the entire common mode range allows the unused devices on the bus to be powered down.
- Pin out compatible with DS3695/A and SN75176A/B.
- Combined impedance of a driver output and receiver input is less than one RS485 unit load, allowing up to 32 transceivers on the bus.
- 70 mV typical receiver hysteresis.

Connection and Logic Diagram

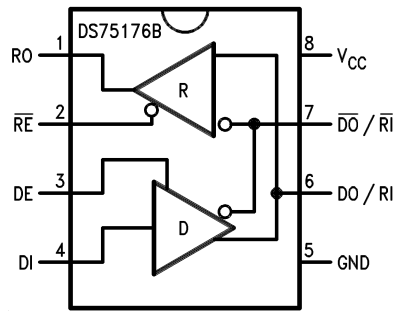

Top View
Order Number DS75176BN, DS75176BTN, DS75176BM or DS75176BTM
See NS Package Number N08E or M08A

TRI-STATE® is a registered trademark of National Semiconductor Corp.

Absolute Maximum Ratings (Note 1)

If Military/Aerospace specified devices are required, please contact the National Semiconductor Sales Office/Distributors for availability and specifications.

Supply Voltage, V_{CC}	7V
Control Input Voltages	7V
Driver Input Voltage	7V
Driver Output Voltages	+15V/ -10V
Receiver Input Voltages (DS75176B)	+15V/ -10V
Receiver Output Voltage	5.5V
Continuous Power Dissipation @ 25°C	
for M Package	675 mW (Note 5)
for N Package	900 mW (Note 4)
Storage Temperature Range	-65°C to +150°C
Lead Temperature (Soldering, 4 seconds)	260°C

ESD Rating (HBM)

500V

Recommended Operating Conditions

	Min	Max	Units
Supply Voltage, V_{CC}	4.75	5.25	V
Voltage at Any Bus Terminal (Separate or Common Mode)	-7	+12	V
Operating Free Air Temperature T_A			
DS75176B	0	+70	°C
DS75176BT	-40	+85	°C
Differential Input Voltage, VID (Note 6)	-12	+12	V

Electrical Characteristics (Notes 2, 3)

0°C ≤ T_A ≤ 70°C, 4.75V < V_{CC} < 5.25V unless otherwise specified

Symbol	Parameter	Conditions	Min	Typ	Max	Units	
V_{OD1}	Differential Driver Output Voltage (Unloaded)	$I_O = 0$			5	V	
V_{OD2}	Differential Driver Output Voltage (with Load)	(Figure 1)					
		R = 50Ω; (RS-422) (Note 7) R = 27Ω; (RS-485)	2			V	
ΔV_{OD}	Change in Magnitude of Driver Differential Output Voltage For Complementary Output States	(Figure 1)			0.2	V	
V_{OC}	Driver Common Mode Output Voltage		R = 27Ω			3.0	V
ΔV_{OC}	Change in Magnitude of Driver Common Mode Output Voltage For Complementary Output States					0.2	V
V_{IH}	Input High Voltage	DI, DE, \overline{RE} , E	2			V	
V_{IL}	Input Low Voltage				0.8		
V_{CL}	Input Clamp Voltage		$I_{IN} = -18$ mA			-1.5	
I_{IL}	Input Low Current		$V_{IL} = 0.4$ V			-200	μA
I_{IH}	Input High Current		$V_{IH} = 2.4$ V			20	μA
I_{IN}	Input Current	DO/RI, $\overline{DO}/\overline{RI}$	$V_{CC} = 0$ V or 5.25 V DE = 0 V	$V_{IN} = 12$ V $V_{IN} = -7$ V		+1.0 -0.8	mA
V_{TH}	Differential Input Threshold Voltage for Receiver		$-7V \leq V_{CM} \leq +12V$		-0.2	+0.2	V
ΔV_{TH}	Receiver Input Hysteresis		$V_{CM} = 0$ V		70		mV
V_{OH}	Receiver Output High Voltage		$I_{OH} = -400$ μA	2.7			V
V_{OL}	Output Low Voltage	RO	$I_{OL} = 16$ mA (Note 7)			0.5	V
I_{OZR}	OFF-State (High Impedance) Output Current at Receiver		$V_{CC} = \text{Max}$ $0.4V \leq V_O \leq 2.4V$			±20	μA
R_{IN}	Receiver Input Resistance		$-7V \leq V_{CM} \leq +12V$	12			kΩ
I_{CC}	Supply Current	No Load (Note 7)				55	mA
		Driver Outputs Enabled Driver Outputs Disabled				35	mA

Electrical Characteristics (Notes 2, 3) (Continued)
 $0^{\circ}\text{C} \leq T_A \leq 70^{\circ}\text{C}$, $4.75\text{V} < V_{CC} < 5.25\text{V}$ unless otherwise specified

Symbol	Parameter	Conditions	Min	Typ	Max	Units
I_{OSD}	Driver Short-Circuit Output Current	$V_O = -7\text{V}$ (Note 7)			-250	mA
		$V_O = +12\text{V}$ (Note 7)			+250	mA
I_{OSR}	Receiver Short-Circuit Output Current	$V_O = 0\text{V}$	-15		-85	mA

Note 1: "Absolute Maximum Ratings" are those beyond which the safety of the device cannot be guaranteed. They are not meant to imply that the device should be operated at these limits. The tables of "Electrical Characteristics" provide conditions for actual device operation.

Note 2: All currents into device pins are positive; all currents out of device pins are negative. All voltages are referenced to device ground unless otherwise specified.

Note 3: All typicals are given for $V_{CC} = 5\text{V}$ and $T_A = 25^{\circ}\text{C}$.

Note 4: Derate linearly at $5.56\text{ mW}/^{\circ}\text{C}$ to 650 mW at 70°C .

Note 5: Derate linearly @ $6.11\text{ mW}/^{\circ}\text{C}$ to 400 mW at 70°C .

Note 6: Differential - Input/Output bus voltage is measured at the noninverting terminal A with respect to the inverting terminal B.

Note 7: All worst case parameters for which note 7 is applied, must be increased by 10% for DS75176BT. The other parameters remain valid for $-40^{\circ}\text{C} < T_A < +85^{\circ}\text{C}$.

Switching Characteristics
 $V_{CC} = 5.0\text{V}$, $T_A = 25^{\circ}\text{C}$

Symbol	Parameter	Conditions	Min	Typ	Max	Units
t_{PLH}	Driver Input to Output	$R_{LDIFF} = 60\Omega$		12	22	ns
t_{PHL}	Driver Input to Output	$C_{L1} = C_{L2} = 100\text{ pF}$		17	22	ns
t_r	Driver Rise Time	$R_{LDIFF} = 60\Omega$			18	ns
t_f	Driver Fall Time	$C_{L1} = C_{L2} = 100\text{ pF}$ (Figure 3 and Figure 5)			18	ns
t_{ZH}	Driver Enable to Output High	$C_L = 100\text{ pF}$ (Figure 4 and Figure 6) S1 Open		29	100	ns
t_{ZL}	Driver Enable to Output Low	$C_L = 100\text{ pF}$ (Figure 4 and Figure 6) S2 Open		31	60	ns
t_{LZ}	Driver Disable Time from Low	$C_L = 15\text{ pF}$ (Figure 4 and Figure 6) S2 Open		13	30	ns
t_{HZ}	Driver Disable Time from High	$C_L = 15\text{ pF}$ (Figure 4 and Figure 6) S1 Open		19	200	ns
t_{PLH}	Receiver Input to Output	$C_L = 15\text{ pF}$ (Figure 2 and Figure 7)		30	37	ns
t_{PHL}	Receiver Input to Output	S1 and S2 Closed		32	37	ns
t_{ZL}	Receiver Enable to Output Low	$C_L = 15\text{ pF}$ (Figure 2 and Figure 8) S2 Open		15	20	ns
t_{ZH}	Receiver Enable to Output High	$C_L = 15\text{ pF}$ (Figure 2 and Figure 8) S1 Open		11	20	ns
t_{LZ}	Receiver Disable from Low	$C_L = 15\text{ pF}$ (Figure 2 and Figure 8) S2 Open		28	32	ns
t_{HZ}	Receiver Disable from High	$C_L = 15\text{ pF}$ (Figure 2 and Figure 8) S1 Open		13	35	ns

AC Test Circuits

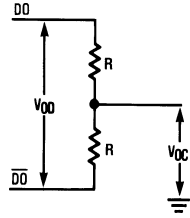

00875902

FIGURE 1.

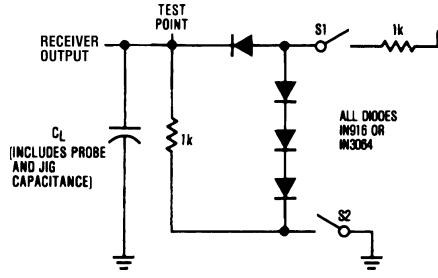

00875903

Note: S1 and S2 of load circuit are closed except as otherwise mentioned.

FIGURE 2.

Switching Time Waveforms

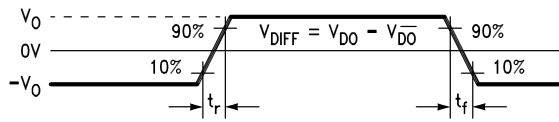
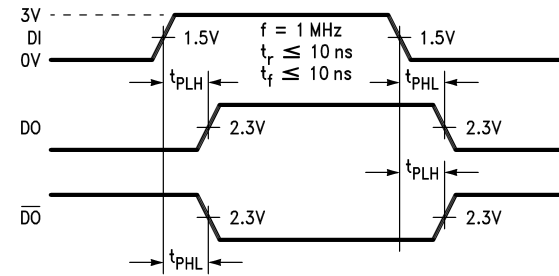

00875906

FIGURE 5. Driver Propagation Delays and Transition Times

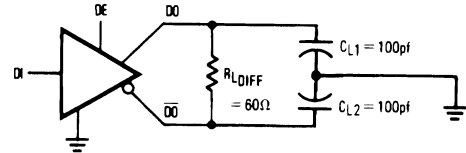

00875904

FIGURE 3.

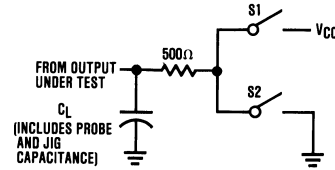

00875905

Note: Unless otherwise specified the switches are closed.

FIGURE 4.

Switching Time Waveforms (Continued)

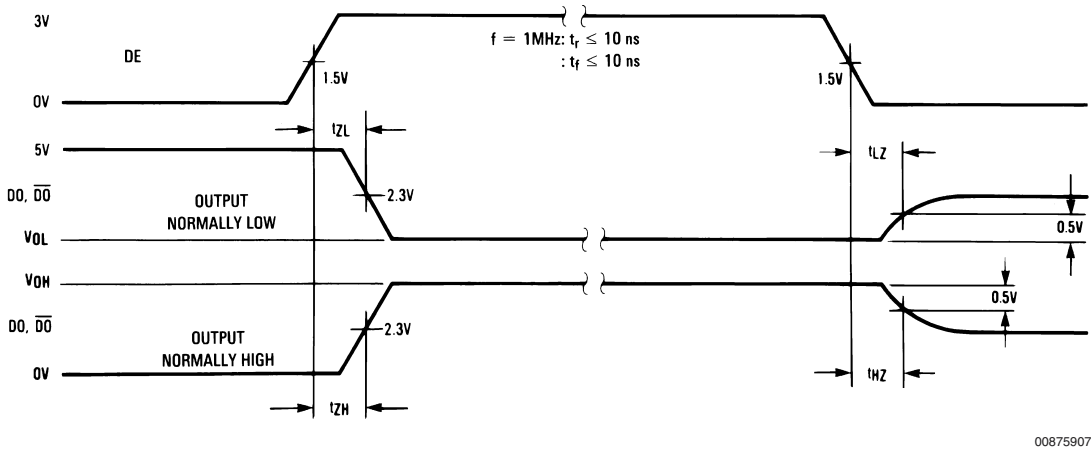
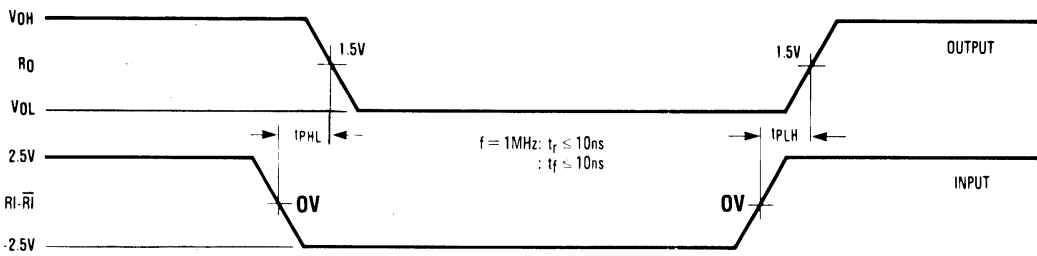

FIGURE 6. Driver Enable and Disable Times



Note: Differential input voltage may be realized by grounding $\overline{R1}$ and pulsing $R1$ between +2.5V and -2.5V

FIGURE 7. Receiver Propagation Delays

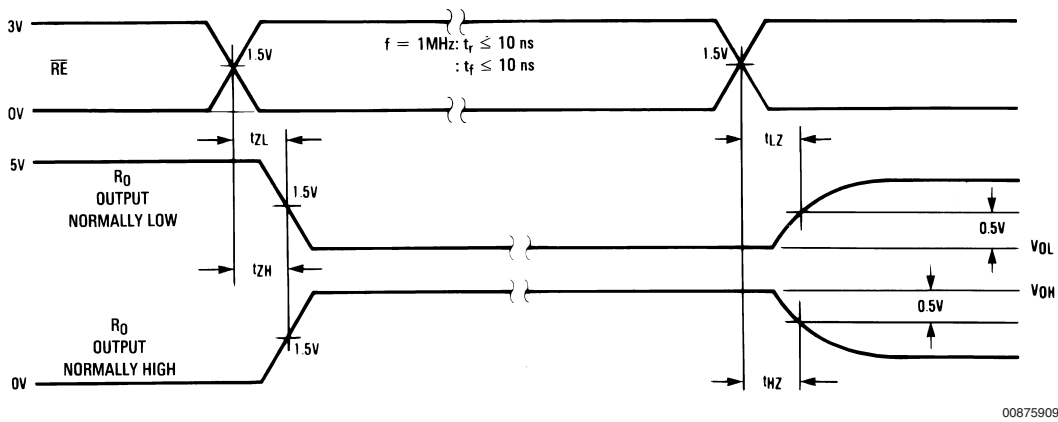

FIGURE 8. Receiver Enable and Disable Times

Function Tables

DS75176B Transmitting

Inputs			Line Condition	Outputs	
RE	DE	DI		DO	DO
X	1	1	No Fault	0	1
X	1	0	No Fault	1	0
X	0	X	X	Z	Z
X	1	X	Fault	Z	Z

DS75176B Receiving

Inputs			Outputs
RE	DE	RI-RI	RO
0	0	$\geq +0.2V$	1
0	0	$\leq -0.2V$	0
0	0	Inputs Open**	1
1	0	X	Z

X — Don't care condition

Z — High impedance state

Fault — Improper line conditions causing excessive power dissipation in the driver, such as shorts or bus contention situations

**This is a fail safe condition

Typical Application

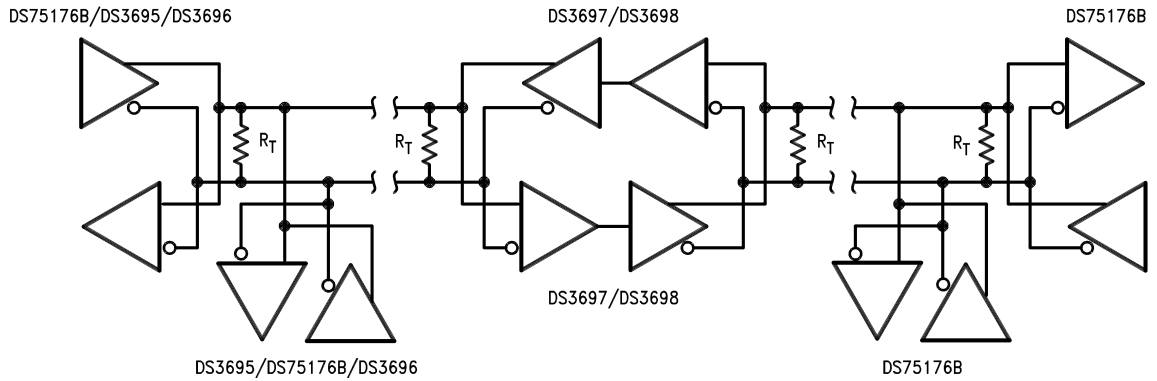

00875911

Physical Dimensions inches (millimeters)

unless otherwise noted

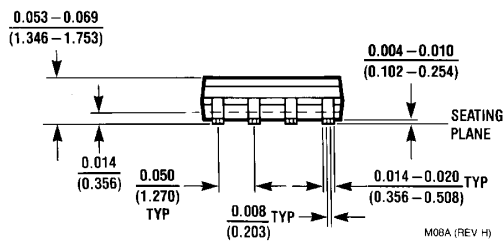
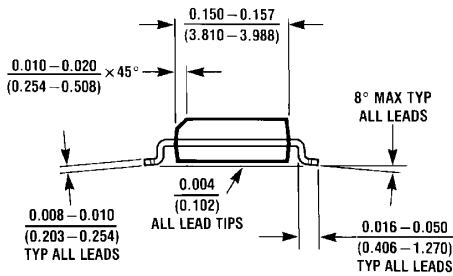
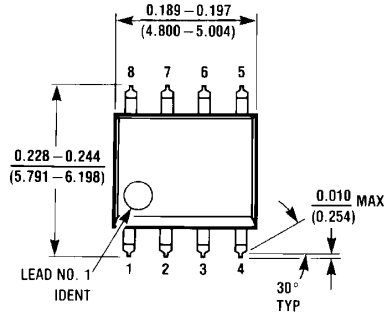

MO8A (REV H)

Lit. # 103669

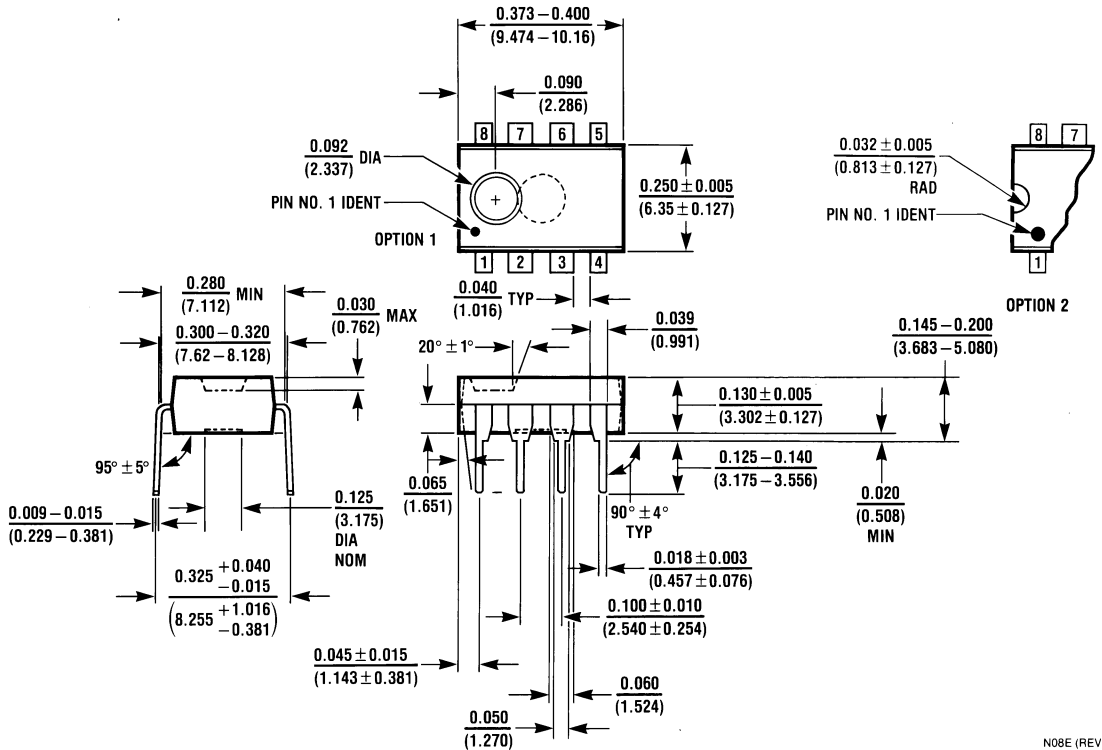

N08E (REV F)

Molded Dual-In-Line Package (N)
Order Number DS75176BN or DS75176BTN
NS Package Number N08E

Notes

LIFE SUPPORT POLICY

NATIONAL'S PRODUCTS ARE NOT AUTHORIZED FOR USE AS CRITICAL COMPONENTS IN LIFE SUPPORT DEVICES OR SYSTEMS WITHOUT THE EXPRESS WRITTEN APPROVAL OF THE PRESIDENT AND GENERAL COUNSEL OF NATIONAL SEMICONDUCTOR CORPORATION. As used herein:

1. Life support devices or systems are devices or systems which, (a) are intended for surgical implant into the body, or (b) support or sustain life, and whose failure to perform when properly used in accordance with instructions for use provided in the labeling, can be reasonably expected to result in a significant injury to the user.
2. A critical component is any component of a life support device or system whose failure to perform can be reasonably expected to cause the failure of the life support device or system, or to affect its safety or effectiveness.

BANNED SUBSTANCE COMPLIANCE

National Semiconductor certifies that the products and packing materials meet the provisions of the Customer Products Stewardship Specification (CSP-9-111C2) and the Banned Substances and Materials of Interest Specification (CSP-9-111S2) and contain no "Banned Substances" as defined in CSP-9-111S2.



National Semiconductor
Americas Customer
Support Center
Email: new.feedback@nsc.com
Tel: 1-800-272-9959

www.national.com

National Semiconductor
Europe Customer Support Center
Fax: +49 (0) 180-530 85 86
Email: europa.support@nsc.com
Deutsch Tel: +49 (0) 69 9508 6208
English Tel: +44 (0) 870 24 0 2171
Français Tel: +33 (0) 1 41 91 8790

National Semiconductor
Asia Pacific Customer
Support Center
Email: ap.support@nsc.com

National Semiconductor
Japan Customer Support Center
Fax: 81-3-5639-7507
Email: jpn.feedback@nsc.com
Tel: 81-3-5639-7560

National Semiconductor was acquired by Texas Instruments.

http://www.ti.com/corp/docs/investor_relations/pr_09_23_2011_national_semiconductor.html

This file is the datasheet for the following electronic components:

DS75176BTMX - <http://www.ti.com/product/ds75176btmx?HQS=TI-null-null-dscatalog-df-pf-null-wwe>

DS75176BTN - <http://www.ti.com/product/ds75176btn?HQS=TI-null-null-dscatalog-df-pf-null-wwe>

DS75176BN - <http://www.ti.com/product/ds75176bn?HQS=TI-null-null-dscatalog-df-pf-null-wwe>

DS75176BTM - <http://www.ti.com/product/ds75176btm?HQS=TI-null-null-dscatalog-df-pf-null-wwe>

DS75176B MDA - http://www.ti.com/product/ds75176b_mda?HQS=TI-null-null-dscatalog-df-pf-null-wwe

DS75176BM - <http://www.ti.com/product/ds75176bm?HQS=TI-null-null-dscatalog-df-pf-null-wwe>

DS75176BMX - <http://www.ti.com/product/ds75176bmx?HQS=TI-null-null-dscatalog-df-pf-null-wwe>



LittleDiode supplies new, hard to find or obsolete electronic components and semiconductors all over the world.

With over two million different components listed you are sure to find the part you need.

Feel free to visit us today at our online store:

LittleDiode.com

Looking forward to providing you with the best possible service.