

DS9639A Dual Differential Line Receiver

General Description

The DS9639A is a Schottky dual differential line receiver which has been specifically designed to satisfy the requirements of EIA Standards RS-422, RS-423 and RS-232C. In addition, the DS9639A satisfies the requirements of MIL-STD 188-114 and is compatible with the International Standard CCITT recommendations. The DS9639A is suitable for use as a line receiver in digital data systems, using either single ended or differential, unipolar or bipolar transmission. It requires a single 5.0V power supply and has Schottky TTL compatible outputs. The DS9639A has an operational input common mode range of $\pm 7.0V$ either differentially or to ground.

Features

- Dual channel
- Single 5.0V supply
- Satisfies EIA Standards RS-422, RS-423 and RS-232C
- Built-in ± 35 mV hysteresis
- High input common mode voltage range
- High input impedance
- TTL compatible outputs
- Schottky technology

Connection Diagram

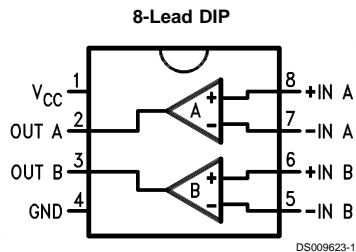

Top View
Order Number DS9639ACN
See NS Package Number N08E

Absolute Maximum Ratings (Note 2)

If Military/Aerospace specified devices are required, please contact the National Semiconductor Sales Office/Distributors for availability and specifications.

Storage Temperature Range	-65°C to +175°C
Operating Temperature Range	0°C to +70°C
Lead Temperature	
Molded DIP (soldering, 10 sec.)	265°C
V _{CC} Lead Potential to Ground	-0.5V to +7.0V
Input Potential to Ground Lead	±25V
Differential Input Voltage	±25V
Output Differential to Ground Lead	-0.5V to 5.5V

Output Sink Current	50 mA
Maximum Power Dissipation (Note 1) at 25°C	
Molded Package	930 mW

Recommended Operating Conditions

	Min	Typ	Max	Units
Supply Voltage (V _{CC})	4.75	5.0	5.25	V
Operating Temperature (T _A)	0	25	70	°C

Note 1: Derate molded DIP package 7.5mW/°C above 25°C.

Electrical Characteristics (Notes 3, 4)

Over recommended operating temperature and supply voltage ranges, unless otherwise specified

Symbol	Parameter	Conditions (Note 2)	Min	Typ	Max	Units
V _{TH}	Differential Input Threshold Voltage (Note 6)	-7.0V ≤ V _{CM} ≤ +7.0V	-0.2		+0.2	V
V _{TH(R)}	Differential Input Threshold Voltage (Note 7)	-7.0V ≤ V _{CM} ≤ +7.0V	-0.4		+0.4	V
I _I	Input Current (Note 8)	V _I = 10V, 0V ≤ V _{CC} ≤ 5.5V		1.1	3.25	mA
		V _I = -10V, 0V ≤ V _{CC} ≤ 5.5V		-1.6	-3.25	
V _{OL}	Output Voltage LOW	I _{OL} = 20 mA, V _{CC} = Min		0.35	0.5	V
V _{OH}	Output Voltage HIGH	I _{OH} = -1.0 mA, V _{CC} = Min	2.5	3.5		V
I _{OS}	Output Short Circuit Current (Note 5)	V _O = 0V, V _{CC} = Max	-40	-75	-100	mA
I _{CC}	Supply Current	V _{CC} = Max, V _{I+} = 0.5V, V _{I-} = GND		35	50	mA
V _{HYST}	Input Hysteresis	V _{CM} = ±7.0V (See Curves)		70		mV

Switching Characteristics

V_{CC} = 5.0V, T_A = 25°C

Symbol	Parameter	Conditions	Min	Typ	Max	Units
t _{PLH}	Propagation Delay Time Low to High	See AC Test Circuit		55	85	ns
t _{PHL}	Propagation Delay Time High to Low	See AC Test Circuit		50	75	ns

Note 2: "Absolute Maximum Ratings" are those values beyond which the safety of the device cannot be guaranteed. They are not meant to imply that the devices should be operated at these limits. The tables of "Electrical Characteristics" provide conditions for actual device operation.

Note 3: Unless otherwise specified min/max limits apply across the 0°C to +70°C range for the DS9639A. All typicals are given for V_{CC} = 5V and T_A = 25°C.

Note 4: All currents into the device pins are positive; all currents out of the device pins are negative. All voltages are referenced to ground unless otherwise specified.

Note 5: Only one output at a time should be shorted.

Note 6: V_{DIFF} (Differential Input Voltage) = (V_{I+}) - (V_{I-}). V_{CM} (Common Mode Input Voltage) = V_{I+} or V_{I-}.

Note 7: 500Ω ±1% in series with inputs.

Note 8: The input not under test is tied to ground.

Equivalent Circuit

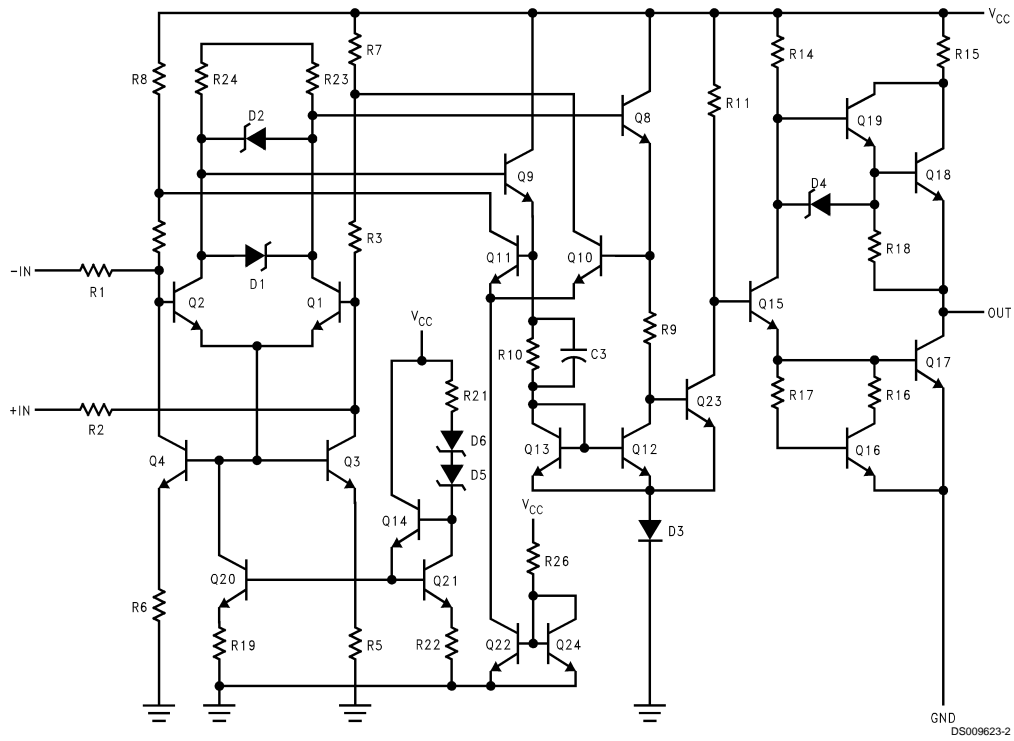

FIGURE 1. Equivalent Circuit

Typical Input/Output Transfer Characteristics

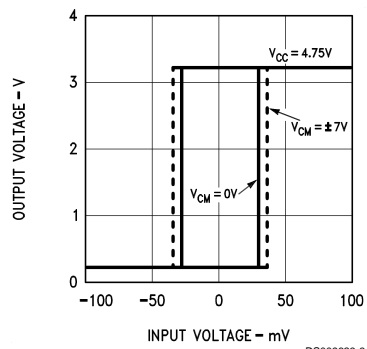

FIGURE 2.

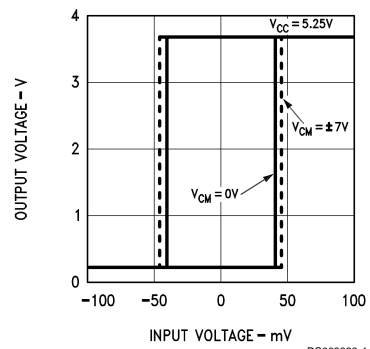
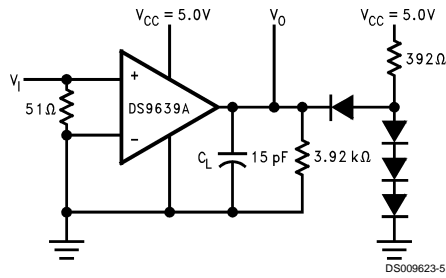

FIGURE 3.

AC Test Circuit and Switching Time Waveform



C_L includes jig and probe capacitance.
All diodes are FD700 or equivalent.

FIGURE 4. AC Test Circuit and Waveforms

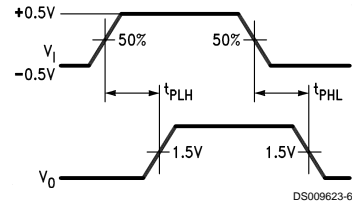

V_1
Amplitude: 1.0V
Offset: 0.5V
Pulse Width: 500 ns
PRR: 1 MHz
 $t_r = t_f \leq 5.0$ ns

FIGURE 5.

Typical Applications

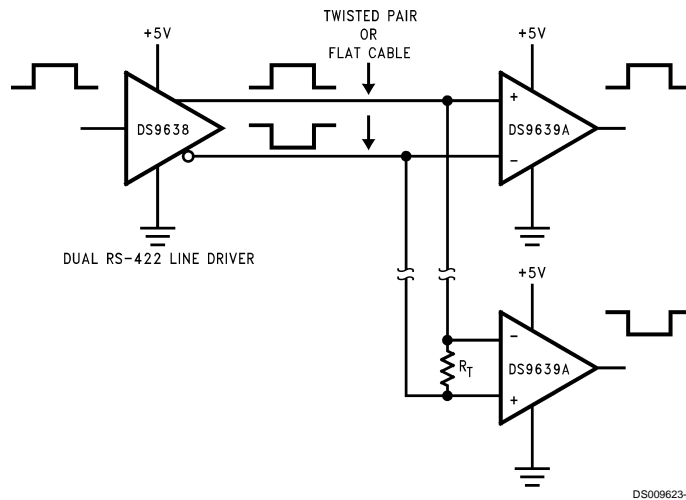

$R_T \geq 50\Omega$ for RS-422 operation.
 R_T combined with input impedance of receivers must be greater than 90Ω .

FIGURE 6. RS-422 System Application (FIPS 1020) Differential Simplex Bus Transmission

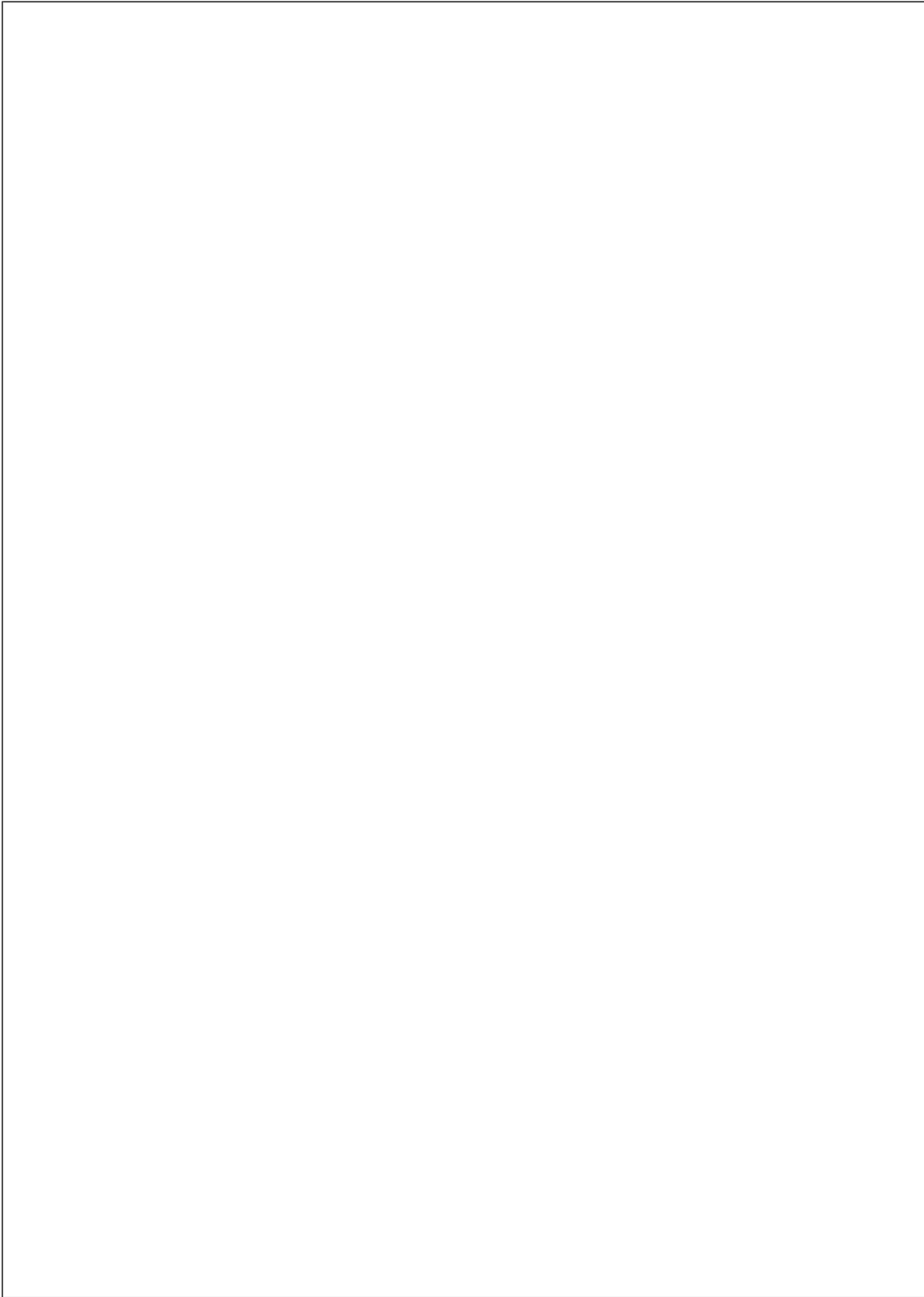

Physical Dimensions inches (millimeters) unless otherwise noted

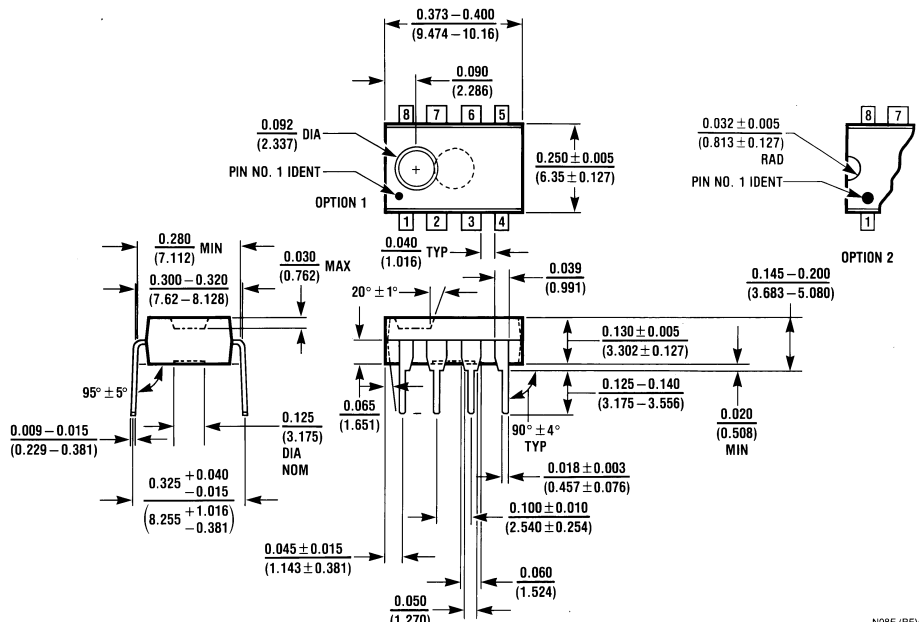

Molded Dual-In-Line Package (N)
Order Number DS9639ACN
NS Package Number N08E

N08E (REV F)

LIFE SUPPORT POLICY

NATIONAL'S PRODUCTS ARE NOT AUTHORIZED FOR USE AS CRITICAL COMPONENTS IN LIFE SUPPORT DEVICES OR SYSTEMS WITHOUT THE EXPRESS WRITTEN APPROVAL OF THE PRESIDENT OF NATIONAL SEMICONDUCTOR CORPORATION. As used herein:

1. Life support devices or systems are devices or systems which, (a) are intended for surgical implant into the body, or (b) support or sustain life, and whose failure to perform when properly used in accordance with instructions for use provided in the labeling, can be reasonably expected to result in a significant injury to the user.
2. A critical component in any component of a life support device or system whose failure to perform can be reasonably expected to cause the failure of the life support device or system, or to affect its safety or effectiveness.

 **National Semiconductor Corporation**
 Americas
 Tel: 1-800-272-9959
 Fax: 1-800-737-7018
 Email: support@nsc.com

National Semiconductor Europe
 Fax: +49 (0) 1 80-530 85 86
 Email: europe.support@nsc.com
 Deutsch Tel: +49 (0) 1 80-530 85 85
 English Tel: +49 (0) 1 80-532 78 32
 Français Tel: +49 (0) 1 80-532 93 58
 Italiano Tel: +49 (0) 1 80-534 16 80

National Semiconductor Asia Pacific Customer Response Group
 Tel: 65-2544466
 Fax: 65-2504466
 Email: sea.support@nsc.com

National Semiconductor Japan Ltd.
 Tel: 81-3-5620-6175
 Fax: 81-3-5620-6179

www.national.com

This datasheet has been downloaded from:

www.DatasheetCatalog.com

Datasheets for electronic components.

National Semiconductor was acquired by Texas Instruments.

http://www.ti.com/corp/docs/investor_relations/pr_09_23_2011_national_semiconductor.html

This file is the datasheet for the following electronic components:

DS9639 - <http://www.ti.com/product/ds9639?HQS=TI-null-null-dscatalog-df-pf-null-ww>

DS9639ACN - <http://www.ti.com/product/ds9639acn?HQS=TI-null-null-dscatalog-df-pf-null-ww>



LittleDiode supplies new, hard to find or obsolete electronic components and semiconductors all over the world.

With over two million different components listed you are sure to find the part you need.

Feel free to visit us today at our online store:

LittleDiode.com

Looking forward to providing you with the best possible service.