



EFS

Application Specific Discretets
A.S.D.TM

STARLIGHT-KIT

2-CHIPS SET FOR FLUORESCENT LAMP STARTER

FEATURES

- VERY WIDE TEMPERATURE RANGE:
tube ignition from **-30 to +85 °C**
- SINGLE SHOT IGNITION FROM -30 to 0°C :
350mA, 1350V striking pulse
- VERY WIDE POWER RANGE:
Fluorescent tube lamp ignition from **18 to 70W**
- EFS2B driver compatible with **50/60Hz**
operation
- SELECTABLE PREHEAT TIME:
EFS2A driver: **1.5s or 2.56s** (50Hz)
EFS2B driver: **0.74s or 1.24s** (50Hz)
EFS2B driver: **0.62s or 1.03s** (60Hz)
- 8 STRIKING PULSES CAPABILITY:
for very cold environment or ageing lamp
- STARTER SHUTDOWN WITH FAILED LAMP

BENEFITS

- Very low component count: **2 chips** + 7 passive components
- Meet EN55015 standards **WITHOUT** EMI capacitor
- Extended life time of the fluorescent lamp due to smooth and single shot ignition
- High inherent **reliability** and **extended life time** of the starter

DESCRIPTION

The EFS Kit is a 2 chips set used with 7 additional passive components, for Glow switch Starter.

The ASDTM (Application Specific Discretets) includes a bi-directional Power Switch and a Power Supply for the driver.

The driver provides a program to ensure a fully optimised linear fluorescent lamp ignition.

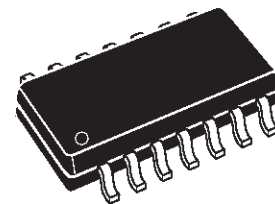

S014
EFS2A-CD
EFS2B-CD

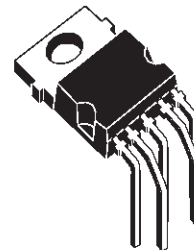

PENTAWATT HV
EFS21-TL5

TM : ASD is trademark of STMicroelectronics.

EFS

PIN CONNECTION (top view)

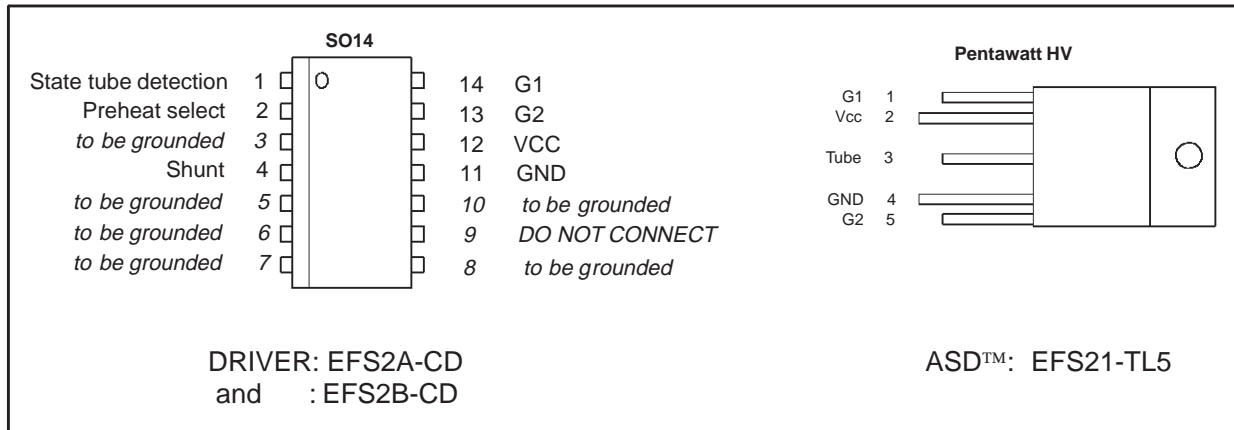

EFS STARLIGHT-KIT PARTS SELECTION:

The EFS STARLIGHT-KIT answers effectively to linear fluorescent lamp ignition needs:

	MAINS FREQUENCY					
	50Hz			60Hz		
DRIVER VERSION	EFS2A		EFS2B			
Pin 2 connection	GND	VCC	GND	VCC	GND	VCC
PREHEAT DURATION	1.5s	2.56s	0.74s	1.24s	0.62s	1.03s
ASD™	EFS21					
LAMP POWER RANGE	18 to 70W (note 2)					
AMBIENT TEMPERATURE RANGE	-30 to 85°C (note1, note 2)					

Note 1: below -20°C, it is recommended to limit the lamp power range to 58W.

Note 2: the ignition temperature range is given with starting aid, as required in the IEC 81 and IEC 926 (§6.3.1) standards.

BASIC APPLICATION DIAGRAM

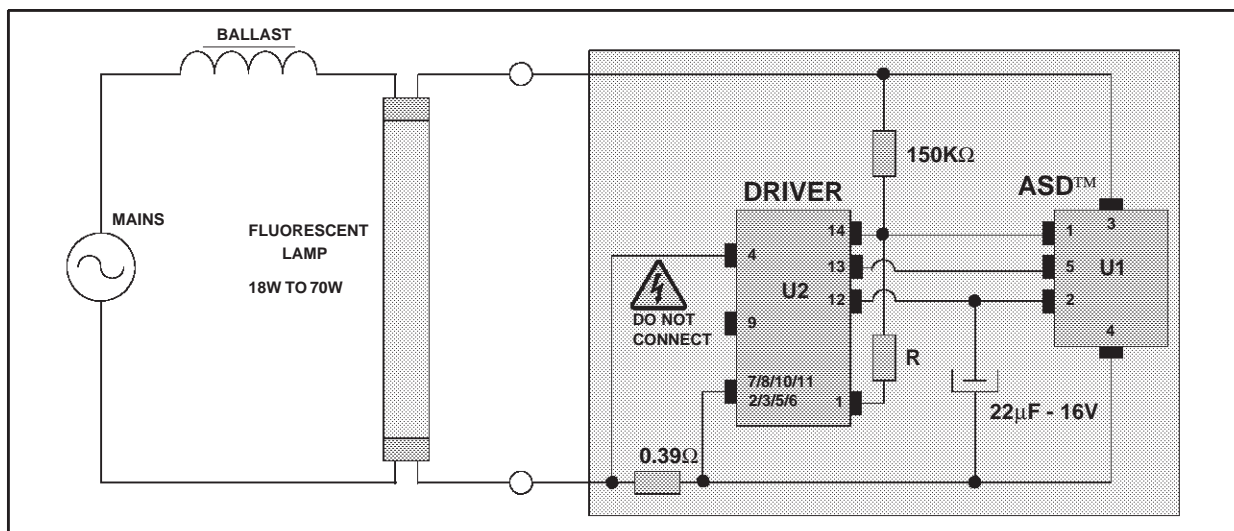

RECOMMENDED LAMP POWER RANGE APPLICATION

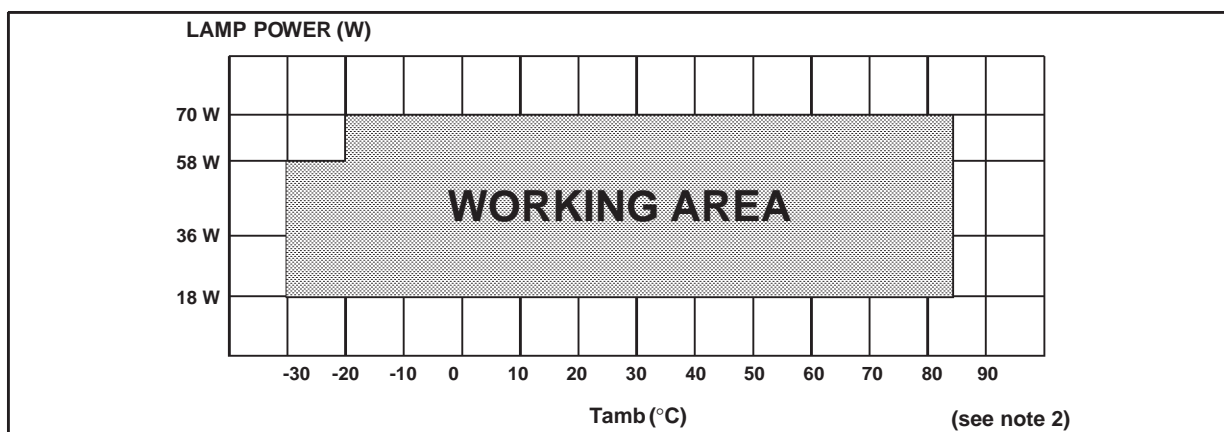

Note 2: the ignition temperature range is given with starting aid, as required in the IEC 81 and IEC 926 (§6.3.1) standards.

ABSOLUTE RATINGS (limiting values)

Symbol	Parameter	Value	Unit
Top	Operating Junction temperature range	-30 to +125	°C
Tstg	Storage temperature range	-55 to +150	°C

DRIVER: EFS2 A & EFS2B

Symbol	Parameter	Value	Unit
Vcc	Maximum supply voltage	14	V
Ptot	Power dissipation	500	mW
ESD	Electrostatic discharge between any pins Standard: MIL STD 883C Human Body Model	1	kV
V _{SENSE}	Input operating range	±10	V

ASD™: EFS21

Symbol	Parameter	Value	Unit
I _{T(RMS)}	RMS on-state current $T_{case} = 90^{\circ}\text{C}$	1	A
T _{case}	I _{T(RMS)} = 1A $t_{OFF} = 0.16\text{s}$ $t_{ON} = 0.75\text{s}$	+ 120	°C
I _{TSM}	Surge peak on-state current T_j initial = 25°C, $t_p = 10\text{ms}$ Minimum repetitive rate periode : 1min.	15	A
V _{DRM} V _{RRM}	Repetitive peak off-state voltage	600	V

EFS

ELECTRICAL CHARACTERISTICS (T_j = 25°C, unless otherwise specified)

DRIVER

Symbol	Parameter	Min.	Typ.	Max.	Unit
V _{CC}	Supply voltage in preheat mode	7		12	V
V _{UVLO}	Under voltage lock-out threshold			5	V
V _{CCH}	Supply limitation high in standby mode	6.8	7.7	8.7	V
V _{CCL}	Supply limitation low in standby mode	6.77	7.57	8.41	V
I _{CC}	Supply current in standby mode	440	450	475	μA
I _{SO}	Ignition current level R _{sense} = 0.39Ω	280	350	420	mA
LAMP OFF STATE DETECTION					
t _c	Checking delay after zero crossing lamp voltage				
	EFS2A version	2.9		5.9	ms
	EFS2B version	2.5		7.5	ms
V _{REF}	Internal reference voltage	1.12		1.26	V

ASD

Symbol	Parameter	Min.	Typ.	Max.	Unit
V _{T+}	Positive on-state voltage I _T = 1.5A t _p = 500μs		2.1	3.15	V
V _{T-}	Negative on-state voltage I _T = 1.5A t _p = 500μs		0.89	1.2	V
V _{BR}	Breakdown positive voltage I _{DRM} = 5mA t _p = 10ms	1200	1350	1500	V
V _{DCM} V _{RCM}	Non repetitive peak off-state voltage Pin 1 = Pin 2 = Pin 4 = Pin 5 Repetitive rate : 3Hz	800			V
I _{DRM} I _{RRM}	Leakage current, at V _{DRM} /V _{RRM} rated Pin 1 = Pin 2 = Pin 4 = Pin 5			20	μA
I _H	Holding current di/dt = 9 A/ms Pin1 = Pin 2 = Pin4 = Pin5	350			mA

ORDERING INFORMATION

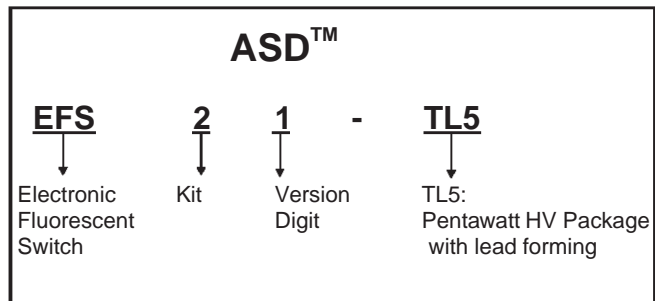
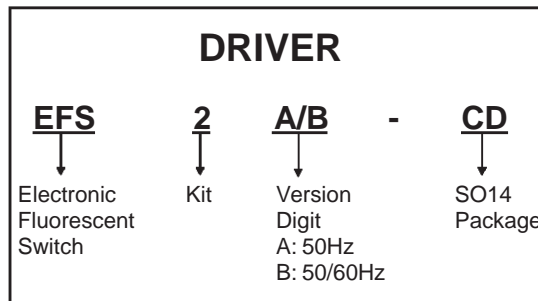

DEMONSTRATION BOARD DIAGRAM

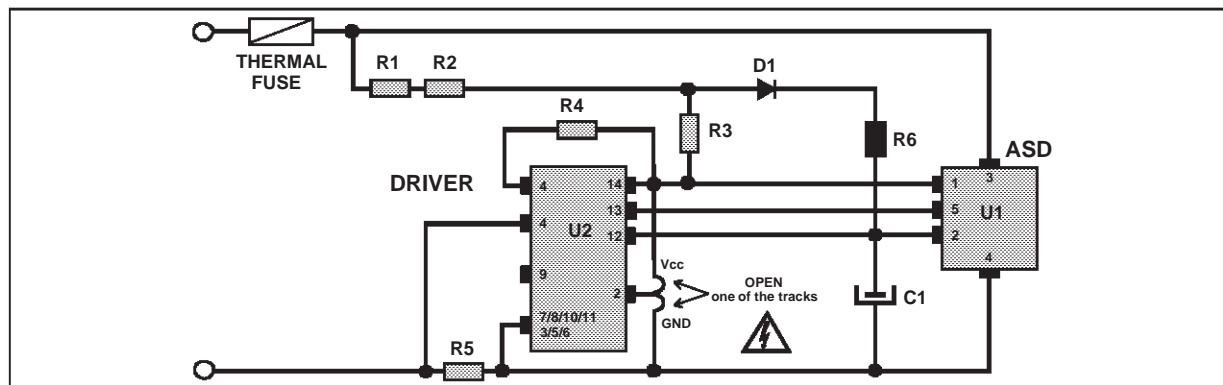

When the starter has to be protected against over-temperature, over-current or short circuit, it is recommended to implement a thermal fuse in series with the starter.
To meet (IEC 926) standards, a capacitor (f.i. 5nF) can be connected between pin 3 and pin 4 of the ASD.

BOARD ASSEMBLY



PCB with Pentawatt HV and SO14

DRILL and CUT the track
for SHORT preheat -->
for LONG preheat -->

Pin 2 is the preheat time select pin. To select a short preheat time, drill to cut the Vcc to pin 2 track at the metallic hole. To select a long preheat time, drill to cut the GND to pin 2 track. The layout must be configured for either choice to avoid **supply short circuit**.

RECOMMENDED COMPONENTS ACCORDING TO APPLICATION CONDITIONS

Application Conditions			
AC mains	Single 230V - 50Hz	Single 120V - 60Hz	Twin series 230V / 50Hz or single 115V / 50Hz
Lamp Power Range	18 to 70W		18 to 36W
Ambient Temperature Range	-30 to + 85°C (note 3)		
Recommended Components			
ASD version	EFS21		
Driver version	EFS2A or EFS2B	EFS2B	EFS2A or EFS2B
R1, R2	30kΩ - 0.125W - 5%	15kΩ - 0.125W - 5%	
R3	130kΩ - 0.125W - 5%		
R4	2.2kΩ - 0.25W - 5%	3.3kΩ - 0.25W - 5%	
R5	0.39Ω - 0.25W - 5% (note 4)		
R6	0.39kΩ - 0.25W - 5%		
C1	22μF - 16V - 20%		
C2	BYD17K (800V)		

Note 3: below -20°C, it is recommended to limit the lamp power range to 58W.

Note 4: R5(Rsense) should have a 8 A, 10 ms surge capability.

EFS STARLIGHT-KIT APPLICATION NOTE

1/ THE AC POWER SWITCH: FUNCTIONAL DESCRIPTION

The Starter is a bi-directional switch which performs two functions:

- the preheat of the tube,
- the ignition of the tube.

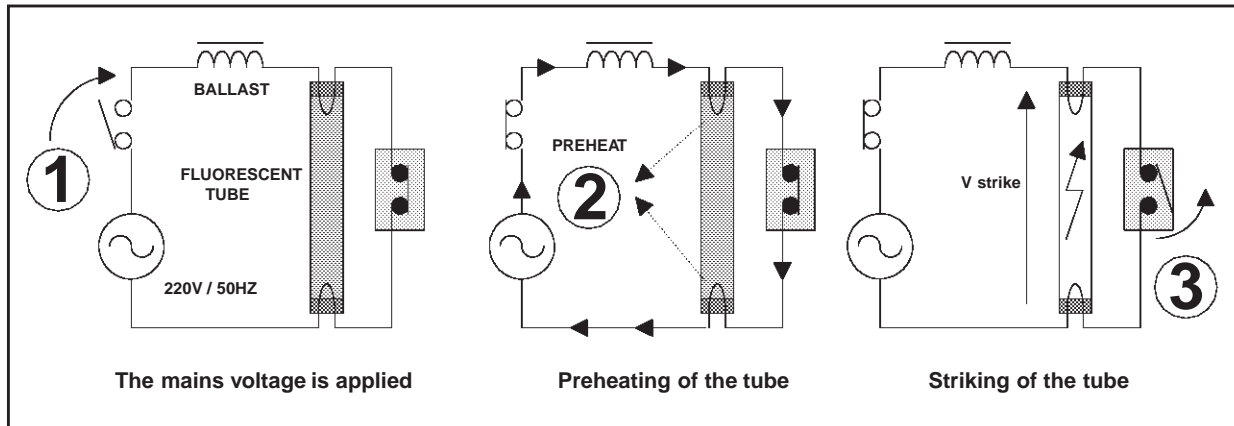

During the preheat period, the ASD™ is fully conducting. The tube lamp is short circuited by the starter, and the current flows through its filaments. In these conditions, the lamp can not light up, but the temperature of the lamp electrodes increases.

At the end of the preheat period, lamp filaments are warm enough to emit electrons in the gas and to permit the lamp ignition in good conditions. The ASD™ switches off the preheating current. At this moment, the ballast is equivalent to a current generator ($I=I_{SO}$, I_{SO} = Switched Off current). As the ASD™ switches off, the starter voltage increases. The amplitude of this high voltage spike is then clamped by the ASD™ (V_{BR} :1350 V). As the starter and the lamp are in parallel, the striking pulse is directly applied to the lamp. The electromagnetic energy of the ballast is then discharged through the lamp and the ASD™.

Striking pulse

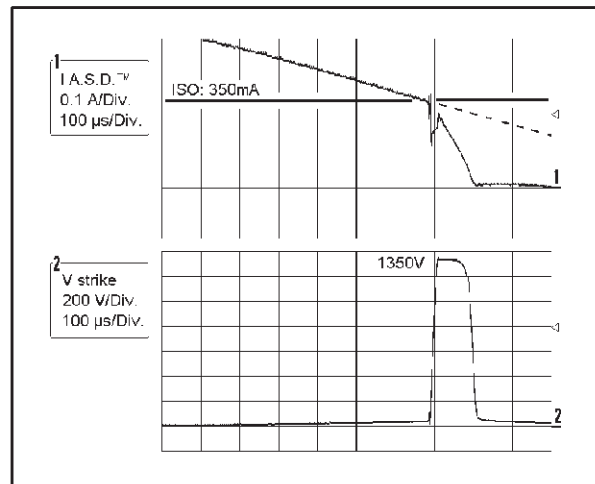

2/ WHAT'S NEW IN THIS SWITCH?

The AC SWITCH merges an auxiliary power supply for the driver, a power clamping device (1350V) and a bi-directional switch with his execution pilot block.

NEW EFS ASD

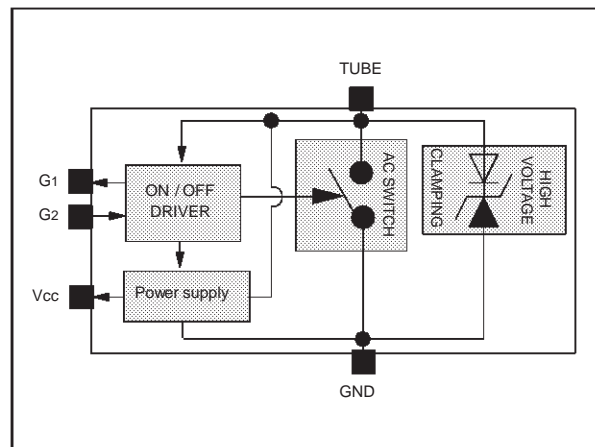

Present solutions work with a unidirectional switch, like MOS transistors or GTO (Gate Turn Off thyristor). As a starter is a bi-directional switch, it is necessary to use a rectifier bridge (4 diodes of 1500V). More, 2 or 3 diodes in series with the GTO are required to get the necessary switch off effect, and the whole is controlled with an analog timer built around a small SCR.

The interest of a bi-directional switch arises itself: a drastic reduction of the number of components, and of course, a reduction of power losses (only 1 forward voltage instead of 5).

Conventional discrete circuit (minimal version)

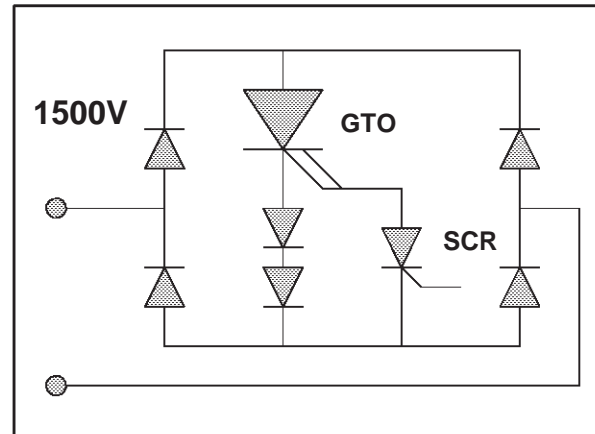

3/ LAMP IGNITION FEATURE:

A lamp requires a minimum energy level to be ignited, but this energy depends especially on the lamp temperature. The lower the temperature is, the more energetic the lamp strike is.

This energy stored in the ballast is directly proportional to the Switched Off current I_{SO} ($E = \frac{L \cdot I_{SO}^2}{2}$).

In other words, the required energy and of course the I_{SO} level, are maximum for the minimum temperature. Results based on experiments show that it is necessary to switch off a current of 350 mA to strike a 58W tube at -30°C (with a voltage amplitude clamped at 1200V and starting aid).

Therefore, the best way to strike a tube independently of the temperature is to keep the maximum I_{SO} level for all the temperature range. Unfortunately, the solution is not so simple to implement because the energy level at ambient or warm temperature would be much important: the lamp would be ignited, but the lamp lifetime would be shortened. This is why one of the innovations of the ASDTM is to modulate the striking energy versus temperature (see feature hereafter).

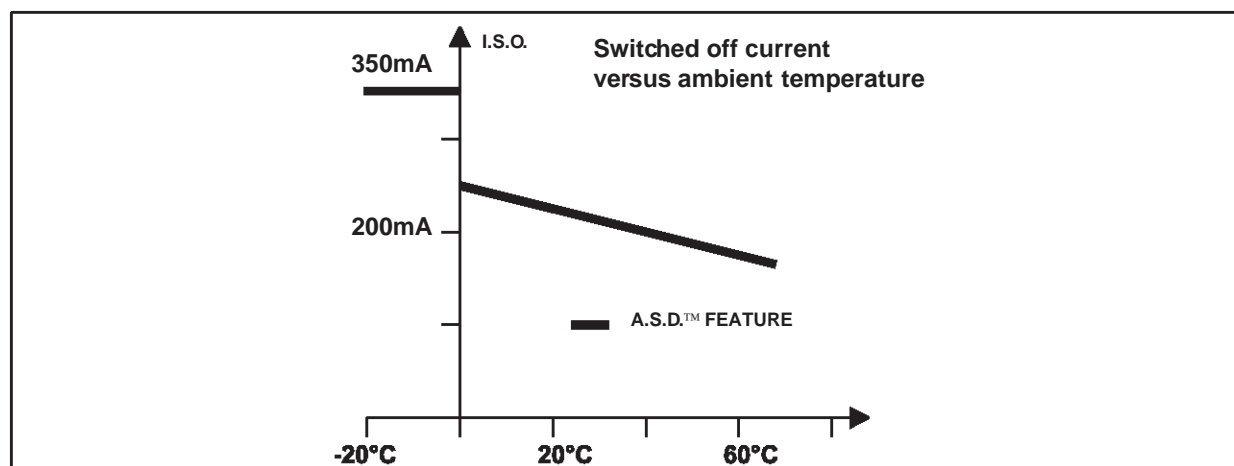

For freezing temperatures, the I_{SO} level is maintained at 350 mA, and for positive temperatures, the I_{SO} level decreases slowly.

4/ AUXILIARY POWER SUPPLY:

In order to reduce the number of components, an auxiliary power supply is integrated in the ASD™. This active power supply works directly on the mains and requires only a low voltage capacitor 16V - 22µF. The operating mode of this supply varies with the starter operating phase:

POWER SUPPLY SCHEMATIC

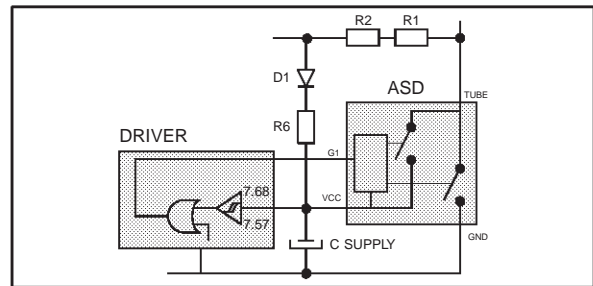

Supply operation during preheat phase:

During preheat phase, the driver manages alone the supply function (neither the driver nor D1 and R6 are involved). A part of the current flowing through the ASD™ is used, at the beginning and at the end of each positive mains half cycle, to charge the output capacitor.

Supply operation during standby phase:

When the lamp is lit, the monitors its supply voltage (Vcc). At the beginning of each positive mains half cycle, when Vcc is lower than 7.57V, the driver closes the ASD™ supply switch. The capacitor is charged to provide the standby current of the driver. During this phase the tube lamp is short circuited by the ASD™. When the supply voltage reaches 7.68V, the driver opens the ASD™ supply switch. Since this current is also flowing in the ballast, the supply turn off provides across the lamp an additional voltage spike. After running few minutes the lamp becomes warm and this spike voltage naturally decreases.

SUPPLY DURING PREHEAT PHASE

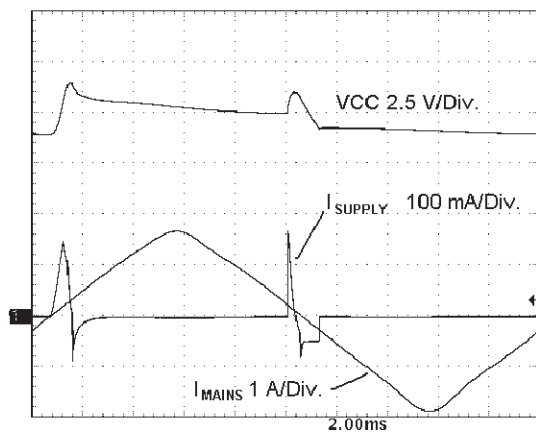

**SUPPLY DURING STANDBY PHASE
(Without E.M.I. Capacitor nor R6 nor D1)**

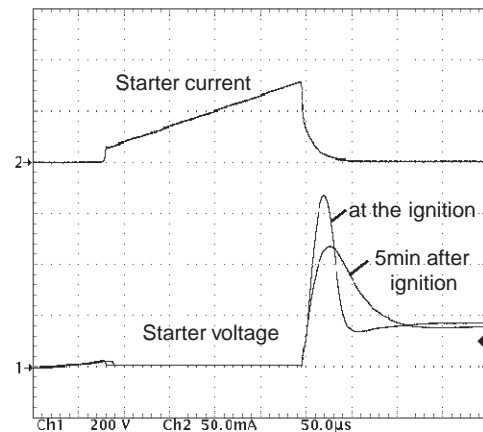

To reduce dramatically this repetitive voltage spikes across the lamp, the R6 resistor with the diode D1 provide a part of the supply current. Thus, the ripple voltage of the supply voltage is reduced, as well as the level of the switched off current. On the other hand, this increases the safety margin of the RF noise (versus the IEC 55015 limits)

5/ THE DRIVER: FUNCTIONAL DESCRIPTION

EFS2A DRIVER Internal block diagram (50Hz operation)

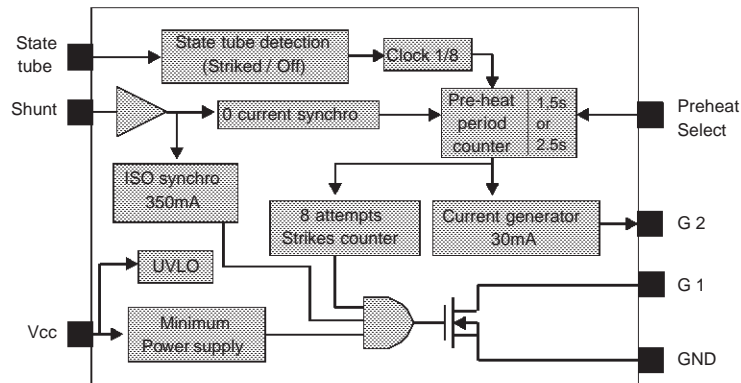

ALGORITHM

1. At switch on:

At switch on, an integrated Under Voltage Lock Out function (UVLO) resets the driver as long as the supply voltage stays below a safety level.

2. Preheat:

The ignition sequence begins with the preheat phase. Two different duration's can be selected with PIN 2 (see table EFS STARLIGHT-KIT PARTS SELECTION page 2).

During this phase, the driver maintains the ASD™ in a full ON-state making the starter equivalent to a bi-directional conducting switch.

3. Ignition of the fluorescent tube:

At the end of the preheat period, the starter strikes the fluorescent lamp.

For that, the driver reads continuously the current through the starter. When the current reaches the Switch Off level ($I_{SO} = 350\text{mA}$), the driver turns off the ASD™. This induces a high voltage pulse across the lamp. This pulse amplitude is limited by the ASD™ (1350V).

4. If the lamp fails to strike:

The driver detects the state of the tube (lit or off). If it stays off during 8 mains cycles (loop 1), a new preheat period, shorter than the first one, starts again (loop 3), followed by a new ignition attempt. The driver will try to fire the tube 8 times. If none of the 8 attempts succeeds in striking the lamp, the driver turns in standby mode, and the whole starter is fully stopped until the next mains removal and power supply reset.

5. If the lamp is ignited:

If the lamp is ignited, the driver stays in standby mode while monitoring the state of the lamp (loop 2). During normal operation of the tube, this short pulse is masked by the lamp conduction. If the mains interruption is really long enough to turn off completely the lamp, a new ignition sequence starts again (loop 3) with 8 other new possible attempts.

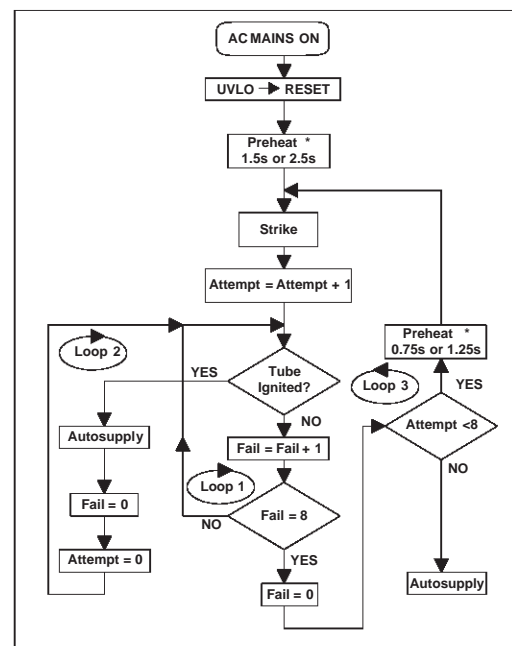

* see the preheat duration table § 6

EFS

6/ PREHEAT PHASE DURATION 50-60Hz:

The driver determines the preheat duration by counting mains cycles. This numeric solution brings naturally a good precision depending only on the mains frequency tolerance.

With the 2 driver versions, the EFS startlight-kit provides a choice of 4 preheat duration's. The following table gives the preheat duration before the first ignition attempt. The seven next preheat duration's, in case of unsuccessful ignition attempt, last the half of the first one

MAINS FREQUENCY	PREHEAT DURATION					
	50Hz				60Hz	
DRIVER VERSION	EFS2A		EFS2B		EFS2B	
Pin 2 connection	GND	VCC	GND	VCC	GND	VCC
		1.5s	2.56s	0.74s	1.24s	0.62s

7/ TUBE STATE DETECTION:

During the ignition sequence or once the lamp is lit, the starter checks the state of the lamp (lit or off). To determine this state, the driver reads the lamp voltage through the resistor bridge (R1+R2+R3, R4).

- If the lamp is off, its voltage equal the mains voltage.
- If the lamp is lit, its voltage is only 80 V (for a 58W lamp).

Thus the lamp state is determined by comparison of the lamp voltage with a programmed detection level.

Tolerance effects:

Tolerances on resistors (R1, R2, R3 and R4) as well as on the integrated comparator bring a tolerance on the set detection level. Thus the detection level is included in a range delimited by the maximum and the minimum detection levels (DL_{MAX} DL_{min}).

The driver checks the state of the lamp when mains voltage is maximum, that is to say 5 ms after the zero crossing mains voltage (50Hz). Here again internal tolerances bring a tolerance on the real checking moment (TC_{min} TC_{MAX}).

CORRECT SETTING = NO WAVEFORM ACROSS THE GREY AREA

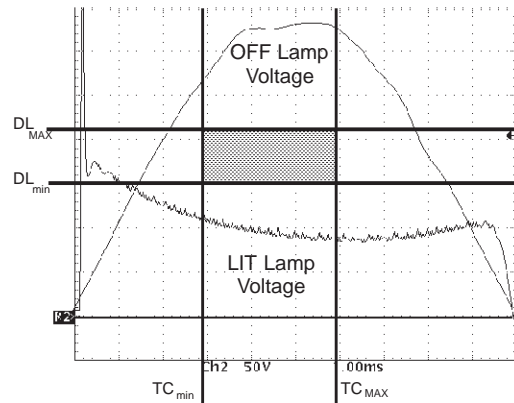

How to set the detection level?

Only the R4 resistor value can be set to adjust the detection level. Values of resistors R1 to R3 must match values of the table RECOMMENDED COMPONENTS ACCORDING TO APPLICATION CONDITIONS of the page 5. Practically the R4 resistor value has to be set so that neither the OFF lamp voltage nor the LIT lamp voltage cross the grey area.

The DL_{MAX} and DL_{min} limits can be calculated as follows:

$$DL_{MAX} = \frac{1.265 \times (R4_{min} + R1_{MAX} + R2_{MAX} + R3_{MAX})}{R4_{min}} \quad \text{and} \quad DL_{min} = \frac{1.122 \times (R4_{MAX} + R1_{min} + R2_{min} + R3_{min})}{R4_{MAX}}$$

8/ E.M.I. CAPACITOR:

As required in the IEC 926 standard (§11.5), "starters which are interchangeable with glow starters in accordance with IEC 155 shall contain means for radio interference suppression, the effect of which is equivalent to that of the radio interference suppression capacitor prescribed in 7.12 of IEC 155".

The EFS starlight-kit is compatible with this 5nF E.M.I. Capacitor which must be connected directly across the ASD™ (between pin 3 "TUBE" and pin 4 "GND").

On the other hand, this E.M.I. capacitor increases the striking pulse width of about 55% on positive temperatures.

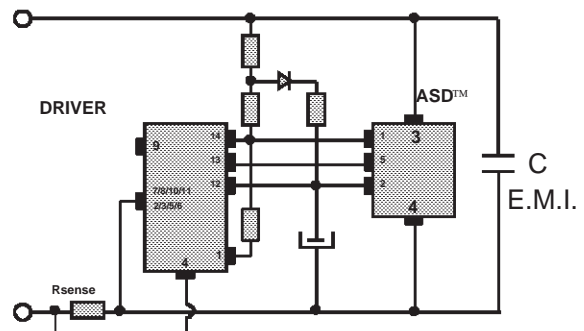

8.1. Operation in single lamp configuration

The EFS STARLIGHT-KIT is ideal in the following configurations:

- Single Starter / 230V / 50Hz - Single Starter / 230V / 60Hz - Single Starter / 120V / 60Hz

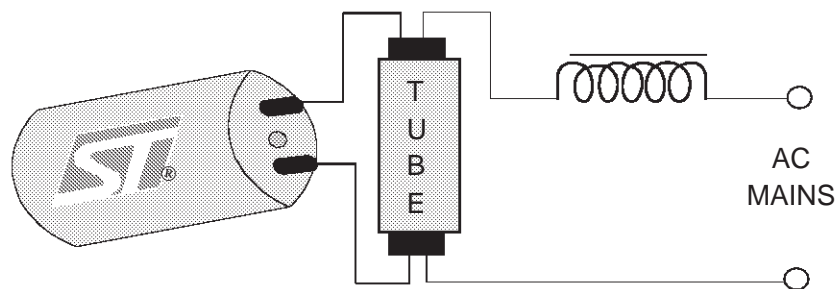

Note 4: the different driver versions should be chosen according to the table "EFS STARLIGHT KIT PARTS SELECTION" page 2.

Note 5: Components to choose are listed in the table "RECOMMENDED COMPONENTS ACCORDING TO APPLICATION CONDITIONS" page 5.

8.2. Operation with capacitor for power factor correction:

The EFS STARLIGHT-KIT is also suitable for magnetic ballast including front end parallel capacitor.

The EFS STARLIGHT-KIT is NOT suitable for magnetic ballast including front end serial capacitor.

LEADING MAGNETIC BALLAST WITH SERIAL CAPACITOR

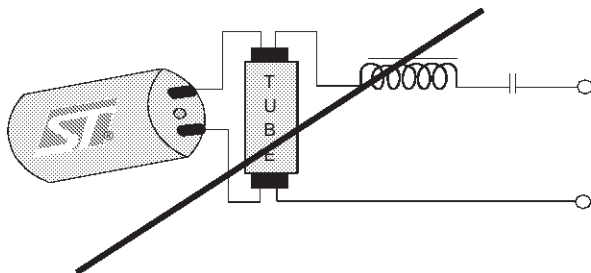

MAGNETIC BALLAST WITH SHUNT PARALLEL CAPACITOR

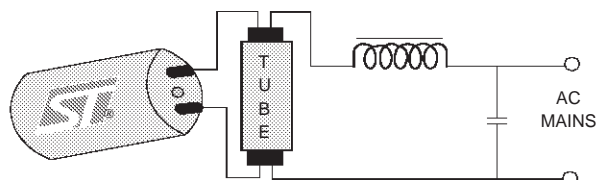

8.3. Operation on the 230V/50Hz AC mains in twin tubes configuration

The EFS STARLIGHT-KIT is also suitable for the configurations Twin tubes Starter

Note 5: Components to choose are listed in the table "RECOMMENDED COMPONENTS ACCORDING TO APPLICATION CONDITIONS" page 5.

The only electrical diagram difference consists of the R4 resistor which needs to be changed from 1 to 2.2kΩ. Without this modification, the starter will generate only one ignition attempt instead of 8 in case of defective lamp; the loop 3 is removed from the algorithm described in page 9.

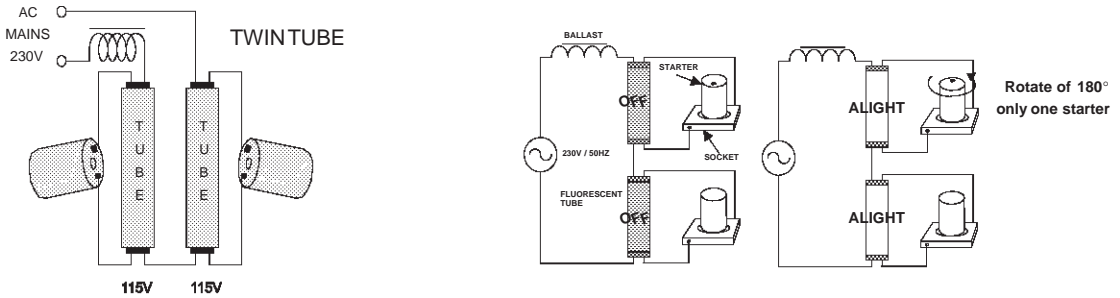

In the Twin Series 230V/50Hz configuration, the polarity of the two starters must be respected:
In case of no operation of starters, rotate one of the starters of 180° on its socket.

PACKAGE MECHANICAL DATA
SO14 (Driver)

Dim.	Millimeters			Inches		
	Min.	Typ.	Max.	Min.	Typ.	Max.
A			1.75			0.069
a1	0.1		0.2	0.004		0.008
a2			1.6			0.063
b	0.35		0.46	0.014		0.018
b1	0.19		0.25	0.007		0.010
C		0.5			0.020	
c1	45° (typ.)					
D	8.55		8.75	0.336		0.334
E	5.8		6.2	0.228		0.244
e		1.27			0.050	
e3		7.62			0.300	
F	3.8		4.0	0.150		0.157
G	4.6		5.3	0.181		0.208
L	0.5		1.27	0.020		0.050
M			0.68			0.027
S	8° (max.)					

PACKAGE MECHANICAL DATA
 Pentawatt HV with lead forming - TL5 (ASD™)

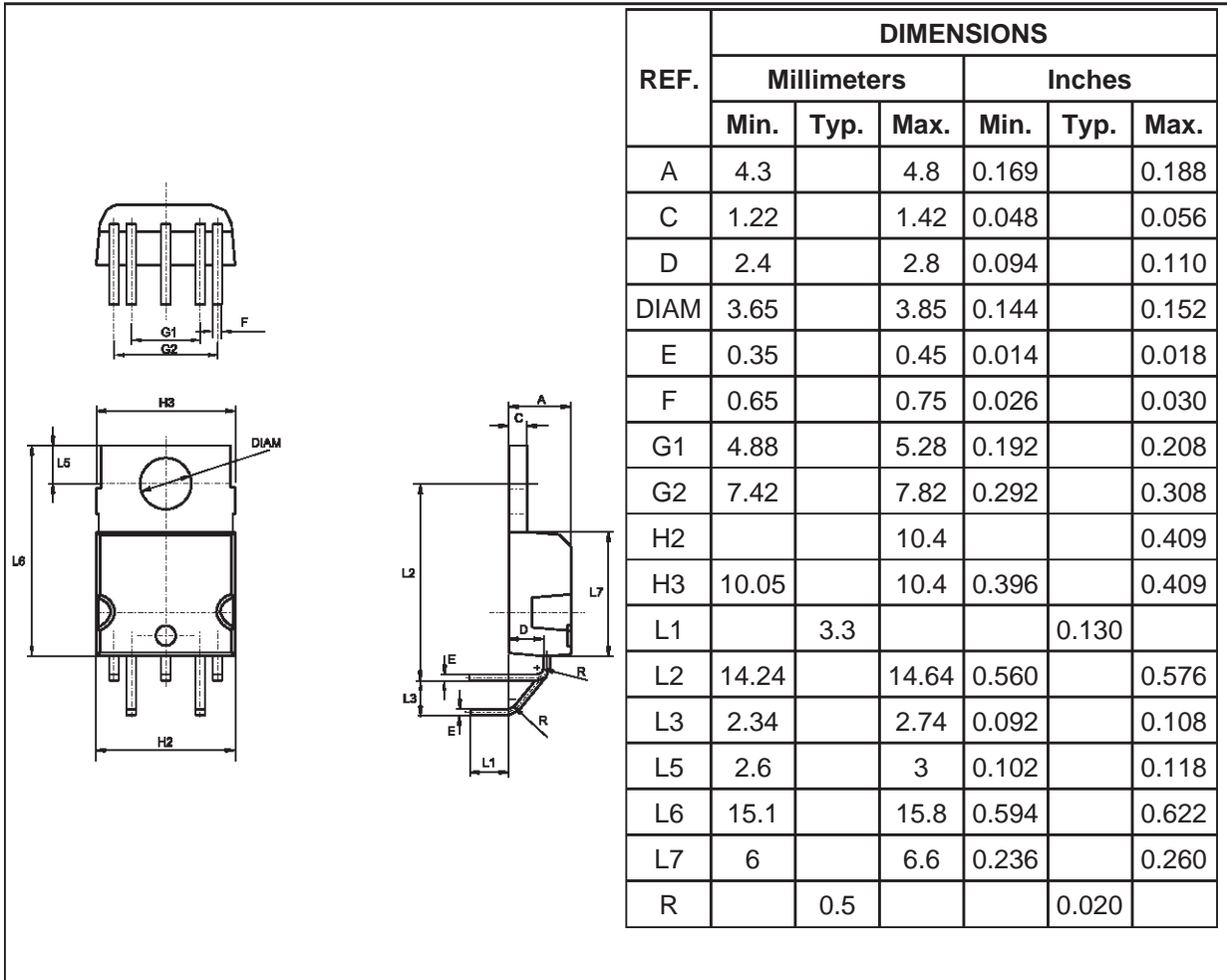

Information furnished is believed to be accurate and reliable. However, STMicroelectronics assumes no responsibility for the consequences of use of such information nor for any infringement of patents or other rights of third parties which may result from its use. No license is granted by implication or otherwise under any patent or patent rights of STMicroelectronics. Specifications mentioned in this publication are subject to change without notice. This publication supersedes and replaces all information previously supplied. STMicroelectronics products are not authorized for use as critical components in life support devices or systems without express written approval of STMicroelectronics.

The ST logo is a registered trademark of STMicroelectronics
 © 2000 STMicroelectronics - Printed in Italy - All rights reserved.

STMicroelectronics GROUP OF COMPANIES
 Australia - Brazil - China - Finland - France - Germany - Hong Kong - India - Italy - Japan - Malaysia
 Malta - Morocco - Singapore - Spain - Sweden - Switzerland - United Kingdom - U.S.A.

<http://www.st.com>



This datasheet has been downloaded from:

www.DatasheetCatalog.com

Datasheets for electronic components.



LittleDiode supplies new, hard to find or obsolete electronic components and semiconductors all over the world.

With over two million different components listed you are sure to find the part you need.

Feel free to visit us today at our online store:

LittleDiode.com

Looking forward to providing you with the best possible service.