

---

# HA16103 FPJ/FPK

## Watchdog Timer

# HITACHI

---

### Description

The HA16103FPJ/FPK monolithic voltage control is designed for microcomputer systems. In addition to voltage regulator, it includes watch dog timer function, power on reset function, and output voltage monitor function.

It is suitable for battery use microcomputer systems.

### Functions

- 5 V regulated power supply
- Power on reset pulse generator
- Watch dog timer
- Low voltage inhibit protection

### Features

- Wide operational supply voltage range ( $V_{CC} = 6$  to 40 V)
- Various control signals are generated when microcomputer system runaway occurs. ( $\overline{NMI}$  signal and  $\overline{STBY}$  signal are generated by detecting voltage level, and  $\overline{RES}$  signal is generated by monitoring the time after  $\overline{NMI}$  signal is detected)
- Regulated voltage,  $\overline{NMI}$  detecting voltage,  $\overline{STBY}$  detecting voltage are adjustable.
- At low voltage and re-start, the delay time of  $\overline{RES}$  signal is adjustable
- Watchdog timer filtering uses the minimum clock input pulse width and maximum cycle detection method

### Ordering Information

Type No.	Package
HA16103FPJ	FP-20DA
HA16103FPK	FP-20DA

---

## Pin Arrangement

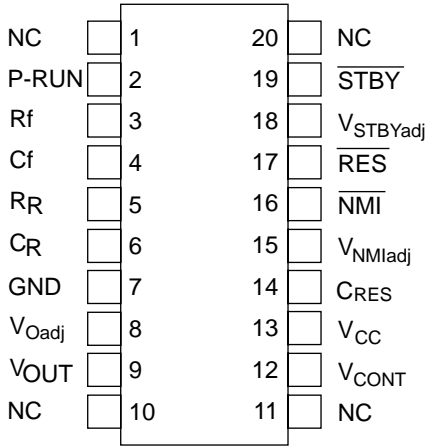

(Top view)

## Pin Functions

No.	Pin Name	Description
1	NC	NC pin
2	P-RUN	P-RUN signal input pin for watchdog timer
3	Rf	Connect resistor Rf. Frequency bandwidth of the filter circuit depends on Rf
4	Cf	Connect resistor Cf. Frequency bandwidth of the filter circuit depends on Cf
5	R <sub>R</sub>	Connect resistor R <sub>R</sub> . Reset-signal power-on time depends on R <sub>R</sub>
6	C <sub>R</sub>	Connect resistor C <sub>R</sub> . Reset-signal power-on time depends on C <sub>R</sub>
7	GND	Ground
8	Voadj	5-V reference voltage fine-tuning pin. Connect a resistor between this pin and GND. The value of output voltage is given by $V_{OUT} = \{1 + 5.34/(R1 // 2.0)\} \times Voadj$ Unit for R1: k $\Omega$
9	V <sub>OUT</sub>	Connect the collector of an external PNP-type transistor. The pin supplies 5-V regulated voltage for internal circuit
10	NC	NC pin
11	NC	NC pin
12	V <sub>CONT</sub>	The external PNP-type transistor's base control pin
13	V <sub>CC</sub>	Supply voltage pin. Operating supply voltage range is 6.0 to 40 V.
14	C <sub>RES</sub>	If the voltage of V <sub>OUT</sub> pin declines to less than Detection voltage(1) (because of an instant power cut or other cause), $\overline{NMI}$ signals are generated. If $t_{RES} \approx 0.5 \cdot Rf \cdot C_{RES}$ (sec) has passed since then, $\overline{RES}$ signals are generated. If the voltage of V <sub>OUT</sub> pin inclines to more than Detection voltage(1) (in case of re-start from LVI state), NMI signals are stop. $t_r \approx 0.5 \cdot Rf \cdot C_{RES}$ (sec) has passed since then, RES signals are stop. Connect capacitor C <sub>RES</sub> between this pin and GND to adjust the $\overline{RES}$ signals delay time ( $t_{RES}$ , $t_r$ ). If delay time is unnecessary, make this pin open ( $t_{RES} = 2 \mu s$ typ. $t_r = 10 \mu s$ typ. at open)
15	V <sub>NMIadj</sub>	$\overline{NMI}$ detection voltage fine-tuning pin. Connect a resistor between this pin and V <sub>OUT</sub> pin or GND. The value of output voltage is given by $V_{NMI} = \{1 + (R2 // 25.5)/(R3 // 10.6)\} \times V_{NMIadj}$ . Unit for R2, R3: k $\Omega$
16	$\overline{NMI}$	$\overline{NMI}$ signal output pin. Connect to pin $\overline{NMI}$ of the microcomputer
17	$\overline{RES}$	$\overline{RES}$ signal output pin. Connect to pin $\overline{RES}$ of the microcomputer
18	V <sub>STBYadj</sub>	$\overline{STBY}$ detection voltage tuning pin. Connect a resistor between this pin and V <sub>OUT</sub> or GND. The value of output voltage is given by $V_{STBY} = 1.89 \times \{1 + 21/(7.9 + 8.85 // R4)\} \times V_{STBYadj}$ Unit for R4: k $\Omega$
19	$\overline{STBY}$	$\overline{STBY}$ signal output pin. Connect to pin $\overline{STBY}$ of the microcomputer
20	NC	NC pin

## Block Diagram

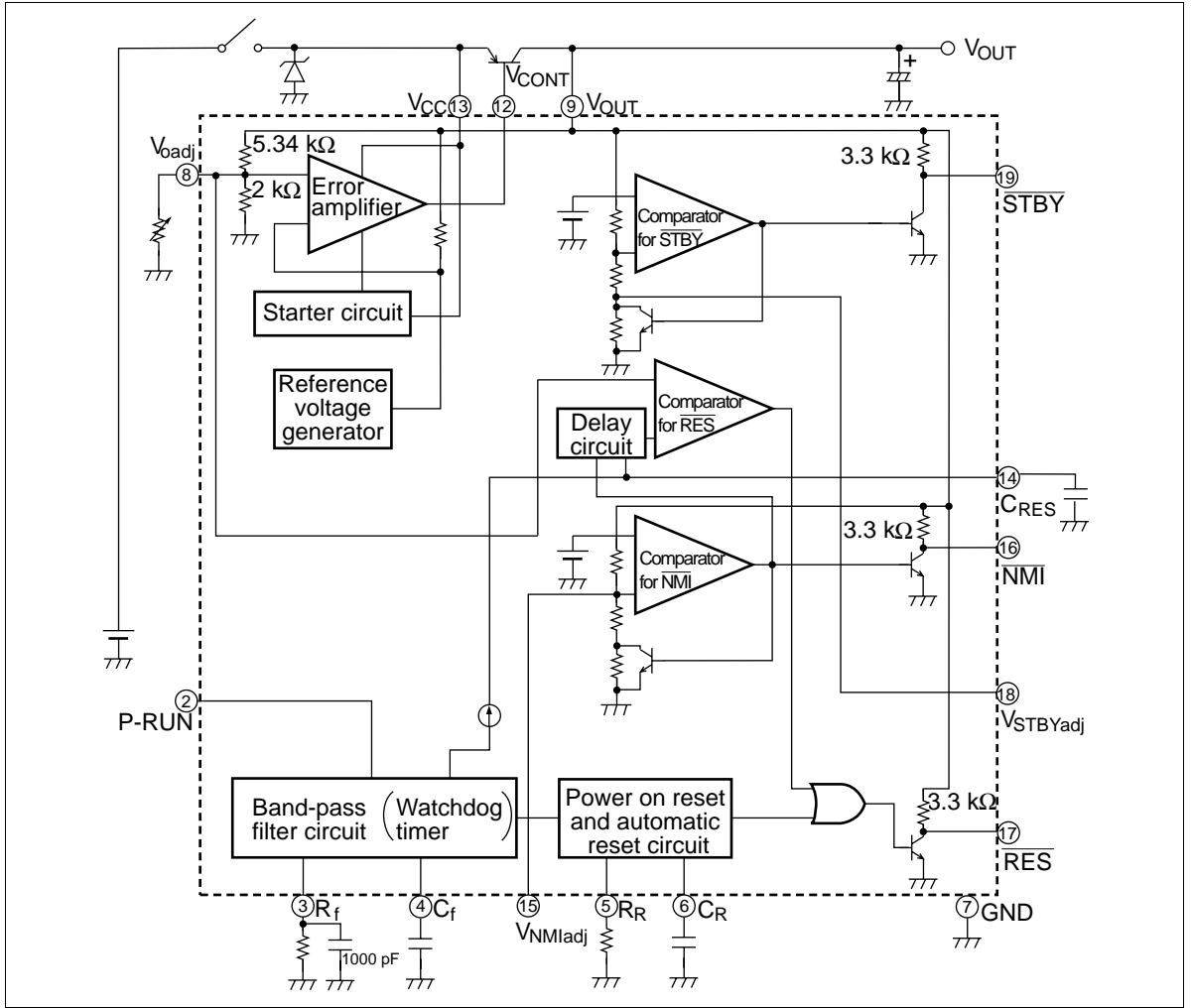

## Functional Description

### Stabilized Power Supply Function

The stabilized power supply includes the following features:

- Wide range of operating input voltage from 6 V to 40 V to provide stabilized voltages
- Availability of any output current, by simply replacing the external transistor
- Fine adjustment of output voltage

Figure 1 shows the fine adjustment circuit of the output circuit. Select the resistor R1 as shown in equation 1.

Add a resistor between GND and Voadj to increase the output voltage.

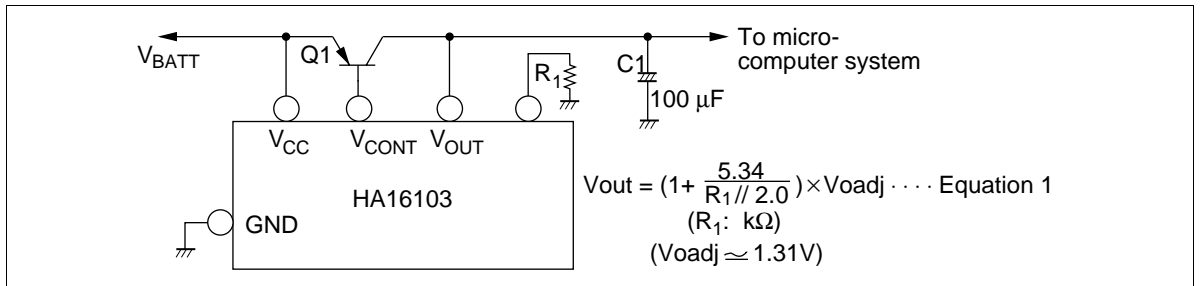

Figure 1 Fine Adjustment Circuit of Output Voltage

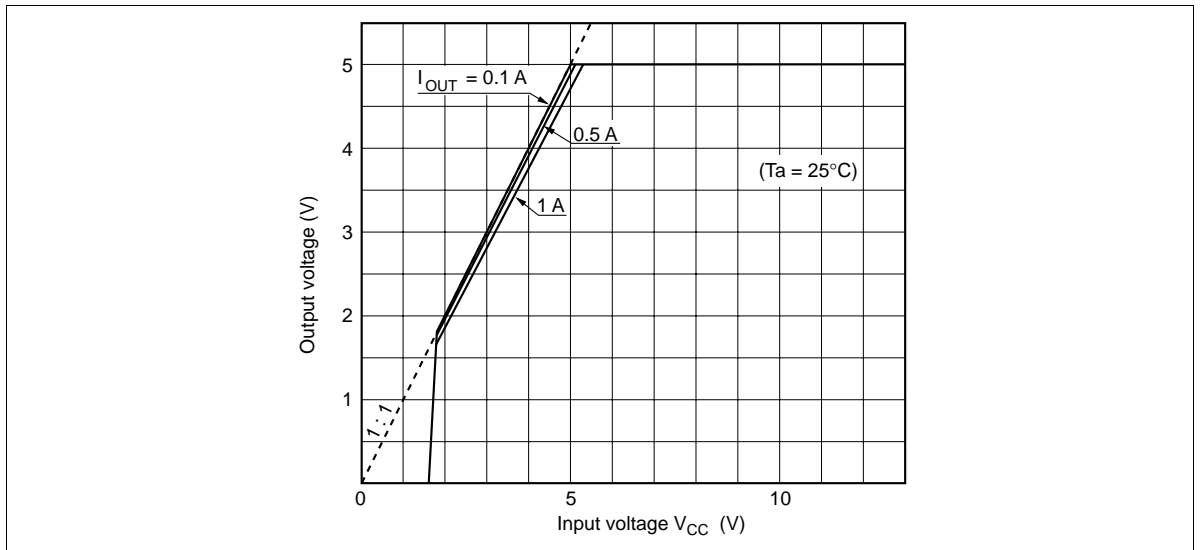
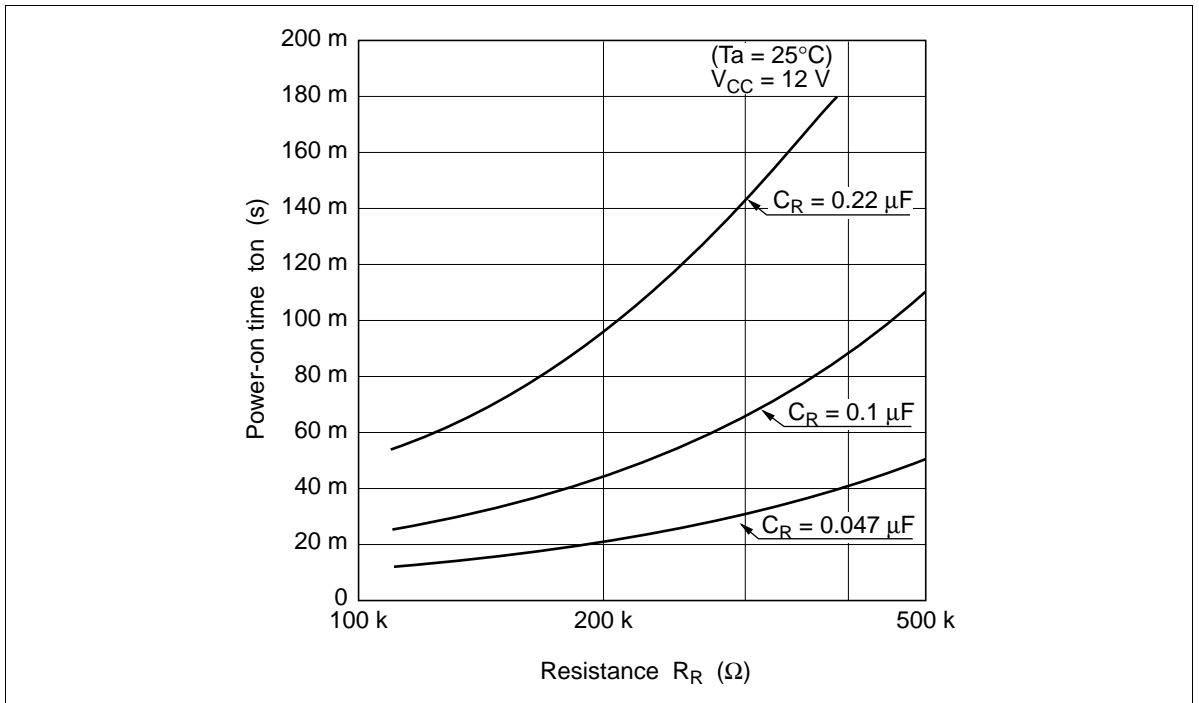
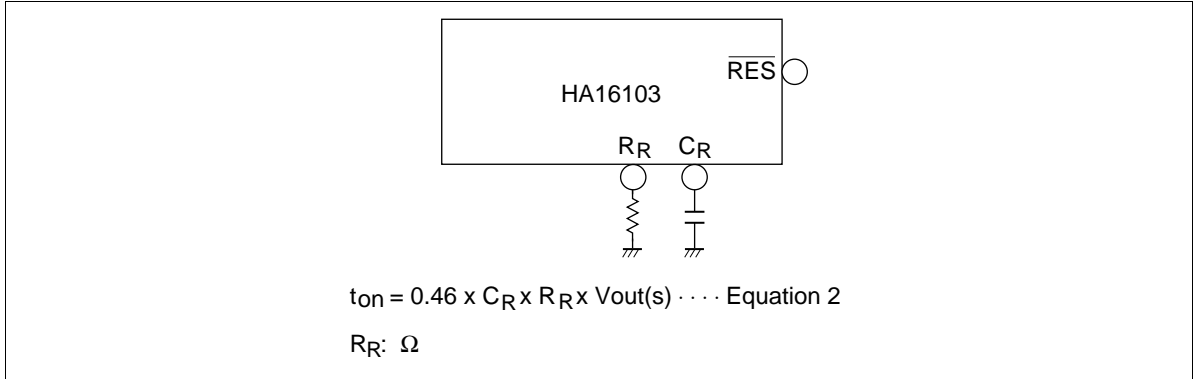

Figure 2 Output Voltage Characteristic

## Power-On Reset Function

The system contains the power-on reset function required when a microcomputer is turned on.

The reset period may be set with external components  $R_R$  and  $C_R$ . Equation 2 specifies how to determine the reset period ( $t_{on}$ ) and figure 3 shows the characteristic of the circuit.

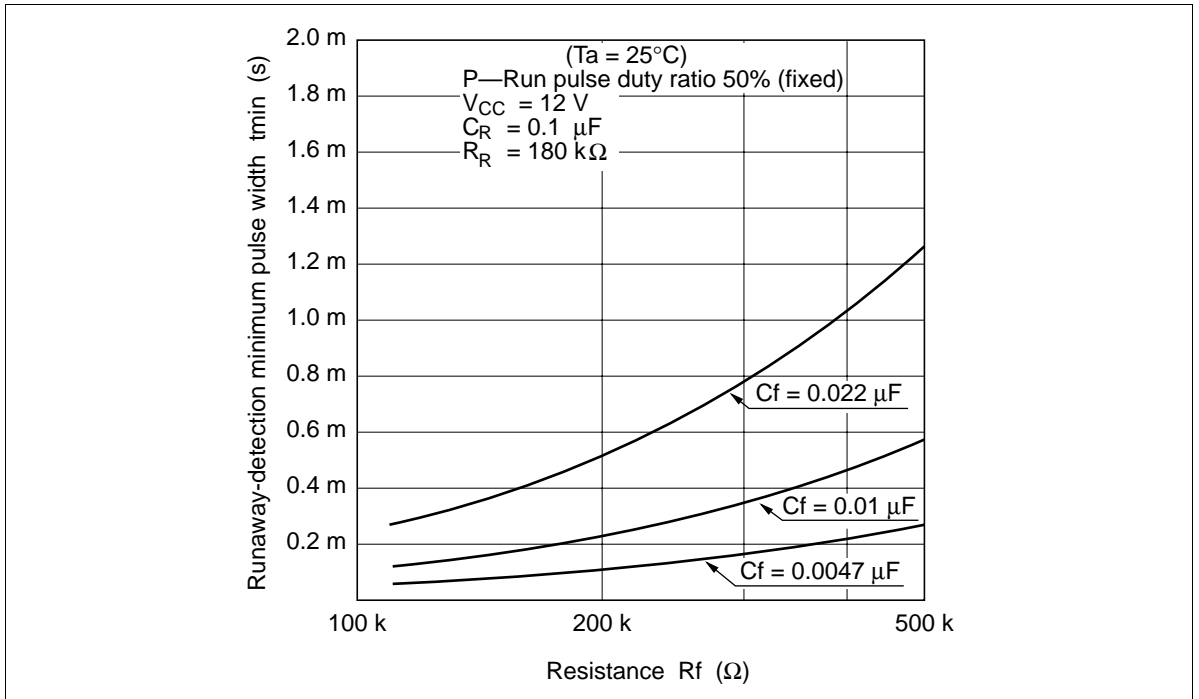
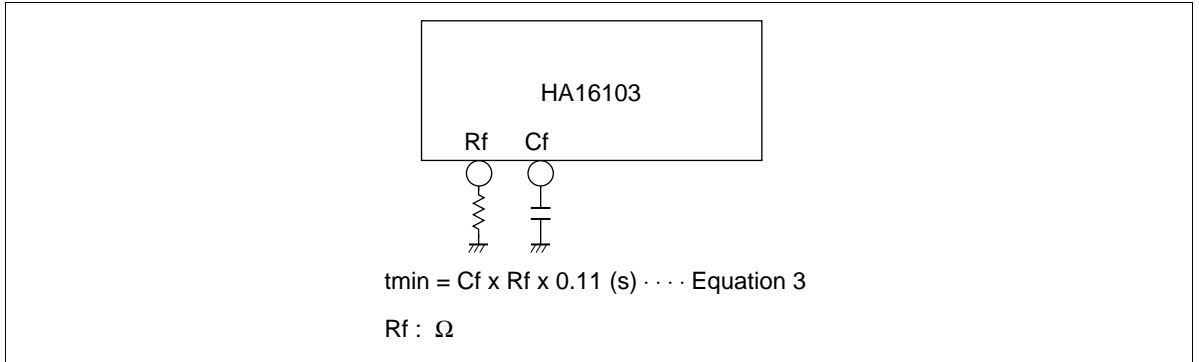

**Figure 3 Characteristic of Power-On Reset Circuit**

**Watchdog Timer Function**

The system contains a bandpass filter for pulse width detection, which outputs a reset pulse when input pulses are not at the preselected frequency (at either a higher or lower frequency).

The RC characteristic of the bandpass filter may be set with external components Rf and Cf. Equation 3 specifies how to determine the minimum pulse width (tmin) for runaway detection of the bandpass filter, and figure 4 shows the characteristic of the filter.



**Figure 4 Characteristic of Power-On Reset Circuit**

## Low Voltage Monitoring Function

The system contains a circuit to send a control signal to the microcomputer when the output voltage drops. The circuit includes the following features.

- Two-point monitoring of output voltage ( $V_{NMI}$  and  $V_{STBY}$ )
- Availability of fine adjustment of  $V_{th1}$  ( $V_{NMI}$ ) and  $V_{th2}$  ( $V_{STBY}$ )
- Output of control signal in standby mode of microcomputer

Figure 5 shows the timing chart of control signals when the output voltage drops.

If the output voltage drops below  $V_{th1}$  (4.60 V), the  $\overline{NMI}$  signal rises to request the microcomputer to issue the  $\overline{NMI}$  interrupt signal. The  $\overline{RES}$  signal falls  $t_{RES}$  seconds after the  $\overline{NMI}$  signal rises. If the output voltage drops further to below  $V_{th2}$  (3.2 V), the  $\overline{STBY}$  signal rises to enable the micro-computer to enter standby mode.

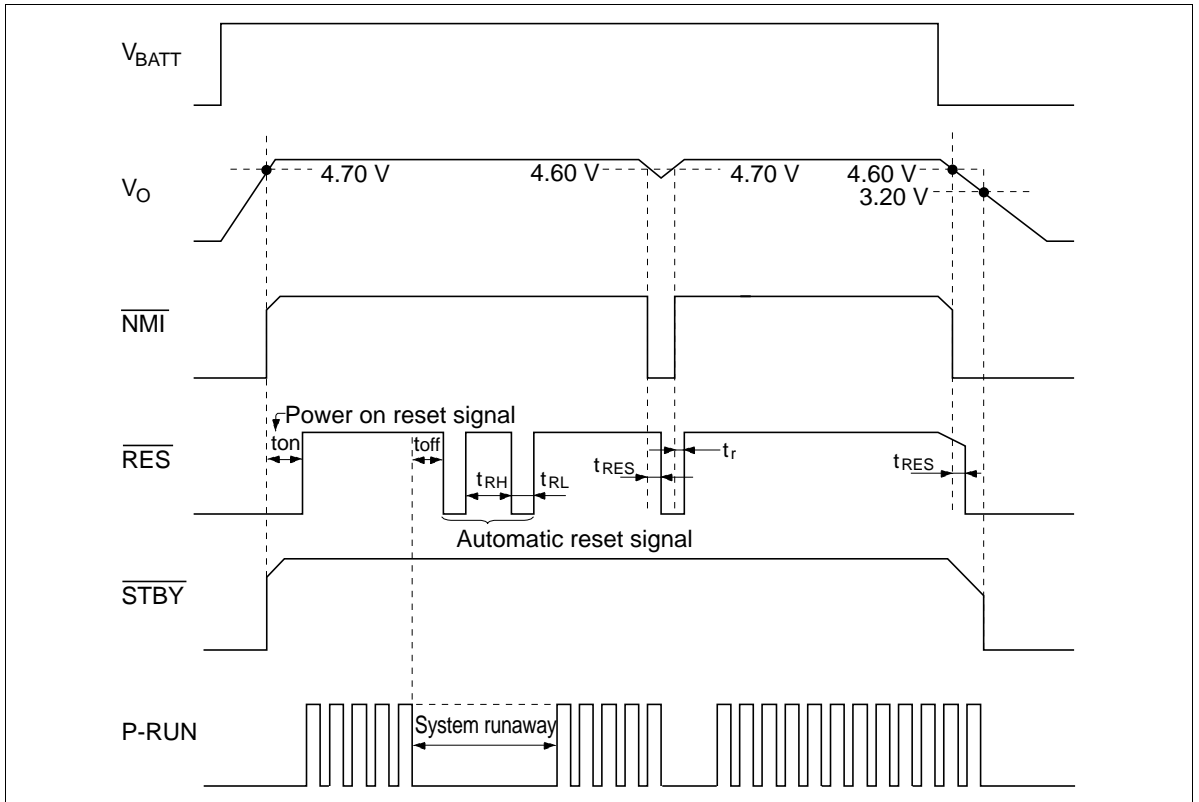

Figure 5 Timing Chart for Low Voltage Monitoring

Absolute Maximum Ratings (Ta = 25°C)

Item	Symbol	Ratings		
		HA16103FPJ	HA16103FPK	Units
V <sub>CC</sub> supply voltage	V <sub>CC</sub>	40	40	V
Control pin voltage	V <sub>CONT</sub>	40	40	V
Control pin current	I <sub>CONT</sub>	20	20	mA
V <sub>OUT</sub> pin voltage	V <sub>OUT</sub>	12	12	V
Power dissipation	P <sub>T</sub>	400* <sup>1</sup>	400* <sup>2</sup>	mW
Operating ambient temperature range	Topr	-40 to +85	-40 to +125	°C
Storage temperature range	Tstg	-50 to +125	-50 to +150	°C

Notes: 1. Value under Ta ≤ 77°C. If Ta is greater, 8.3 mW/°C derating occurs.

2. Allowable temperature of IC junction part, Tj (max), is as shown below.

$$T_j(\text{max}) = \theta_{j-a} \cdot P_c(\text{max}) + T_a$$

(θ<sub>j-a</sub> is thermal resistance value during mounting, and P<sub>c</sub> (max) is the maximum value of IC power dissipation.)

Therefore, to keep Tj (max) ≤ 125°C, wiring density and board material must be selected according to the board thermal conductivity ratio shown below.

Be careful that the value of P<sub>c</sub> (max) does not exceed that P<sub>T</sub>.

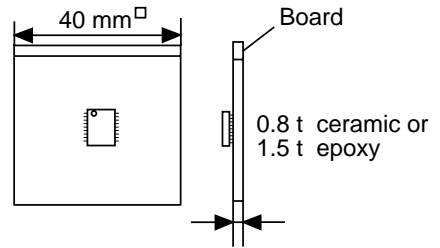
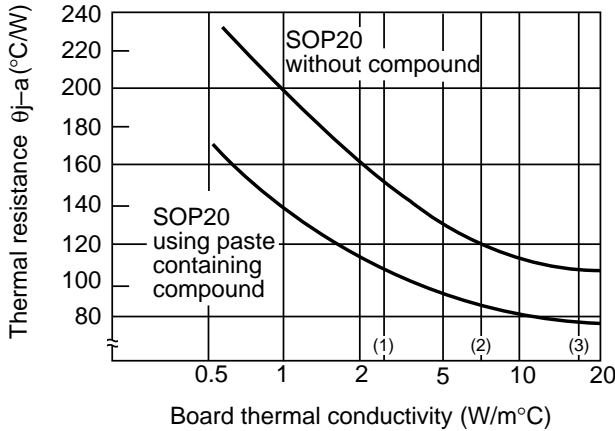

- (1) Glass epoxy board with 10% wiring density
- (2) Glass epoxy board with 30% wiring density
- (3) Ceramic board with 96% alumina coefficient

# HA16103 FPJ/FPK

Electrical Characteristics ( $T_a = 25^\circ\text{C}$ ,  $V_{CC} = 12\text{ V}$ ,  $V_{OUT} = 5\text{ V}$ )

## HA16103FPJ/FPK

Item		Symbol	Min	Typ	Max	Unit	Test Condition
Regulator	Supply current	$I_{CCL}$	—	8	12	mA	$V_{CC} = 12\text{ V}$
	Output voltage	$V_{O1}$	4.80	5.00	5.20	V	$V_{CC} = 6\text{ to }17.5\text{ V}$ $I_{OUT} = 0.5\text{ A}$ , $R_1 = 30\text{ k}\Omega$
		$V_{O2}$	4.70	5.00	5.30	V	$V_{CC} = 6\text{ to }17.5\text{ V}$ $I_{OUT} = 1\text{ A}$ , $R_1 = 30\text{ k}\Omega$
	Line regulation	$V_{oline}$	-50	—	50	mV	$V_{CC} = 6\text{ to }17.5\text{ V}$ $I_{OUT} = 1\text{ A}$ , $R_1 = 30\text{ k}\Omega$
	Load regulation	$V_{oload}$	-100	—	100	mV	$I_{OUT} = 10\text{ mA to }0.5\text{ A}$ , $R_1 = 30\text{ k}\Omega$
	Ripple rejection	$R_{REJ}$	45	75	—	dB	$V_i = 0.5\text{ V}_{rms}$ , $f_i = 1\text{ kHz}$ , $R_1 = 30\text{ k}\Omega$
	Output voltage Temperature coefficient	$\delta V_O / \delta T$	—	0.6	—	mV/°C	$V_{CC} = 12\text{ V}$ , $R_1 = 30\text{ k}\Omega$
Clock input	“L”-input voltage	$V_{IL}$	—	—	0.8	V	
	“H”-input voltage	$V_{IH}$	2.0	—	—	V	
	“L”-input current	$I_{IL}$	-120	-60	—	$\mu\text{A}$	$V_{IL} = 0\text{ V}$
	“H”-input current	$I_{IH}$	—	0.3	0.5	mA	$V_{IH} = 5\text{ V}$

**Electrical Characteristics** ( $T_a = 25^\circ\text{C}$ ,  $V_{CC} = 12\text{ V}$ ,  $V_{OUT} = 5\text{ V}$ ) (cont)

Item		Symbol	Min	Typ	Max	Unit	Test Condition
NMI output	NMI pin "L"-level voltage	$V_{OL1}$	—	—	0.4	V	$I_{OL1} = 2\text{ mA}$
	NMI pin "H"-level voltage	$V_{OH1}$	—	$V_{O1}$ ( $V_{O2}$ )	—	V	
	NMI function start $V_{OUT}$ voltage	$V_{NMI}$	—	0.7	1.4	V	
STBY output	STBY pin "L"-level voltage	$V_{OL2}$	—	—	0.4	V	$I_{OL2} = 2\text{ mA}$
	STBY pin "H"-level voltage	$V_{OH2}$	—	$V_{O1}$ ( $V_{O2}$ )	—	V	
	STBY function start $V_{OUT}$ voltage	$V_{STBY}$	—	0.7	1.4	V	
RES output	RES pin "L"-level voltage	$V_{OL3}$	—	—	0.4	V	$I_{OL3} = 2\text{ mA}$
	RES pin "H"-level voltage	$V_{OH3}$	—	$V_{O1}$ ( $V_{O2}$ )	—	V	
	RES function start $V_{OUT}$ voltage	$V_{RES}$	—	0.7	1.4	V	
	Power on time	$t_{ON}$	25	40	60	ms	$R_f = 180\text{ k}\Omega$ , $R_R = 180\text{ k}\Omega$
	Clock off reset time	$t_{OFF}$	80	130	190	ms	$C_f = 0.01\text{ }\mu\text{F}$ , $C_R = 0.1\text{ }\mu\text{F}$
	Reset pulse "L"-level time	$t_{RL}$	15	20	30	ms	$R_f = 180\text{ k}\Omega$ , $R_R = 180\text{ k}\Omega$ $C_f = 0.01\text{ }\mu\text{F}$ , $C_R = 0.1\text{ }\mu\text{F}$
Reset pulse "H"-level time	$t_{RH}$	37	60	90	ms	$R_f = 180\text{ k}\Omega$ , $R_R = 180\text{ k}\Omega$ $C_f = 0.01\text{ }\mu\text{F}$ , $C_R = 0.1\text{ }\mu\text{F}$	
Low Voltage protecton	Detection voltage(1)	$V_{H1}$	4.40	4.60	4.80	V	
	Detection voltage(1) Hysteresis width	$V_{HYS1}$	50	100	150	mV	
	Detection voltage(2)	$V_{H2}$	2.9	3.2	3.5	V	
	Detection voltage(2) Hysteresis width	$V_{HYS2}$	1.35	1.5	1.65	V	
	Reset pulse	inhibit $t_{RES}$	—	200	—	$\mu\text{s}$	$C_{RES} = 2200\text{ pF}$
Delay time	restart $t_r$	—	200	—	$\mu\text{s}$	$C_{RES} = 2200\text{ pF}$	

# HA16103 FPJ/FPK

**Electrical Characteristics** ( $T_a = -40$  to  $125^\circ\text{C}$ ,  $V_{CC} = 12\text{ V}$ ,  $V_{OUT} = 5\text{ V}$ ,  $R_1 = 30\text{ k}$ )  
(cont)

## HA16103FPK

Item		Symbol	Min	Typ	Max	Unit	Test Condition
	Supply current	$I_{CC1}$	—	7	13	mA	
Regulator	Output voltage	$V_{out1}$	4.80	5.00	5.20	V	$V_{CC} = 6$ to $17.5\text{ V}$ $I_{OUT} = 0.5\text{ A}$
	Line regulation	$V_{oline}$	-50	—	50	mV	$V_{CC} = 6$ to $17.5\text{ V}$ $I_{OUT} = 0.5\text{ A}$
	Load regulation	$V_{oload}$	-100	—	100	mV	$I_{OUT} = 10\text{ mA}$ to $0.5\text{ A}$
Clock input	"L"-input voltage	$V_{IL}$	—	—	0.4	V	
	"H"-input voltage	$V_{IH}$	2.4	—	—	V	
	"L"-input current	$I_{IL}$	-120	-60	—	$\mu\text{A}$	$V_{IL} = 0\text{ V}$
	"H"-input current	$I_{IH}$	—	0.3	0.6	mA	$V_{IH} = 5\text{ V}$
NMI output	NMI pin "L"-level voltage	$V_{OLN}$	—	—	0.5	V	$I_{OL1} = 2\text{ mA}$
	NMI pin "H"-level voltage	$V_{OHN}$	—	$V_{OUT1}$	—	V	
STBY output	STBY pin "L"-level voltage	$V_{OLS}$	—	—	0.5	V	$I_{OL2} = 2\text{ mA}$
	STBY pin "H"-level voltage	$V_{OHS}$	—	$V_{OUT1}$	—	V	
RES output	RES pin "L"-level voltage	$V_{OLR}$	—	—	0.5	V	$I_{OL3} = 2\text{ mA}$
	RES pin "H"-level voltage	$V_{OHR}$	—	$V_{OUT1}$	—	V	
	Power on time	$t_{ON}$	25	40	60	ms	$R_f = 180\text{ k}\Omega$ , $R_R = 180\text{ k}\Omega$
	Clock off reset time	$t_{OFF}$	70	130	200	ms	$C_f = 0.01\text{ }\mu\text{F}$ , $C_R = 0.1\text{ }\mu\text{F}$
	Reset pulse "L"-level time	$t_{RL}$	15	20	30	ms	$R_f = 180\text{ k}\Omega$ , $R_R = 180\text{ k}\Omega$ $C_f = 0.01\text{ }\mu\text{F}$ , $C_R = 0.1\text{ }\mu\text{F}$
	Reset pulse "H"-level time	$t_{RH}$	30	60	100	ms	$R_f = 180\text{ k}\Omega$ , $R_R = 180\text{ k}\Omega$ $C_f = 0.01\text{ }\mu\text{F}$ , $C_R = 0.1\text{ }\mu\text{F}$
Low Voltage protecton	Detection voltage(1)	$V_{NMI}$	4.35	4.60	4.85	V	
	Detection voltage(2)	$V_{STBY}$	2.80	3.20	3.60	V	

Test Circuit

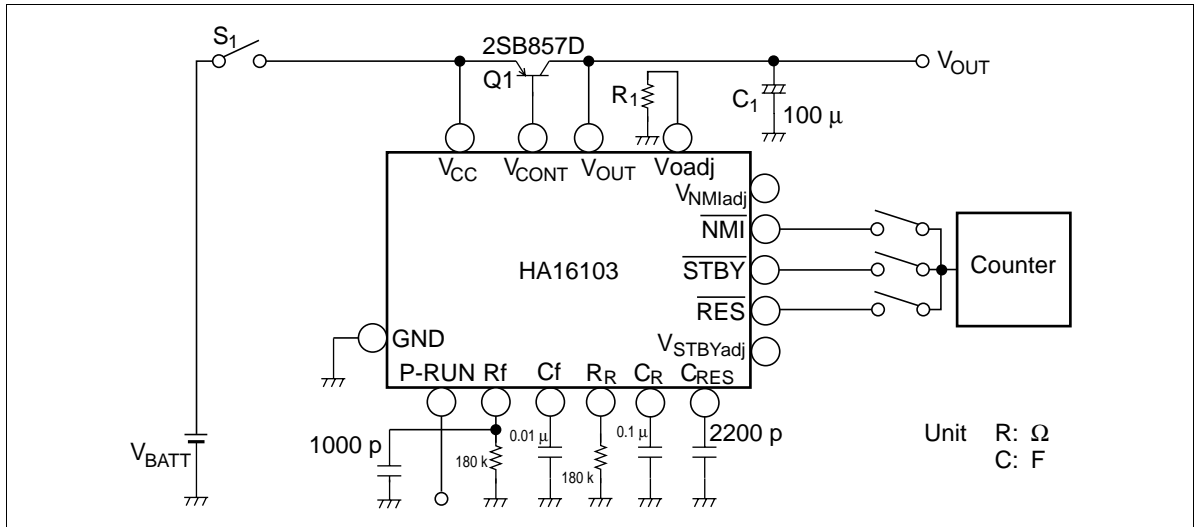

Sample Connection Circuit

Sample Connection Circuit between HA16103 and H8/532

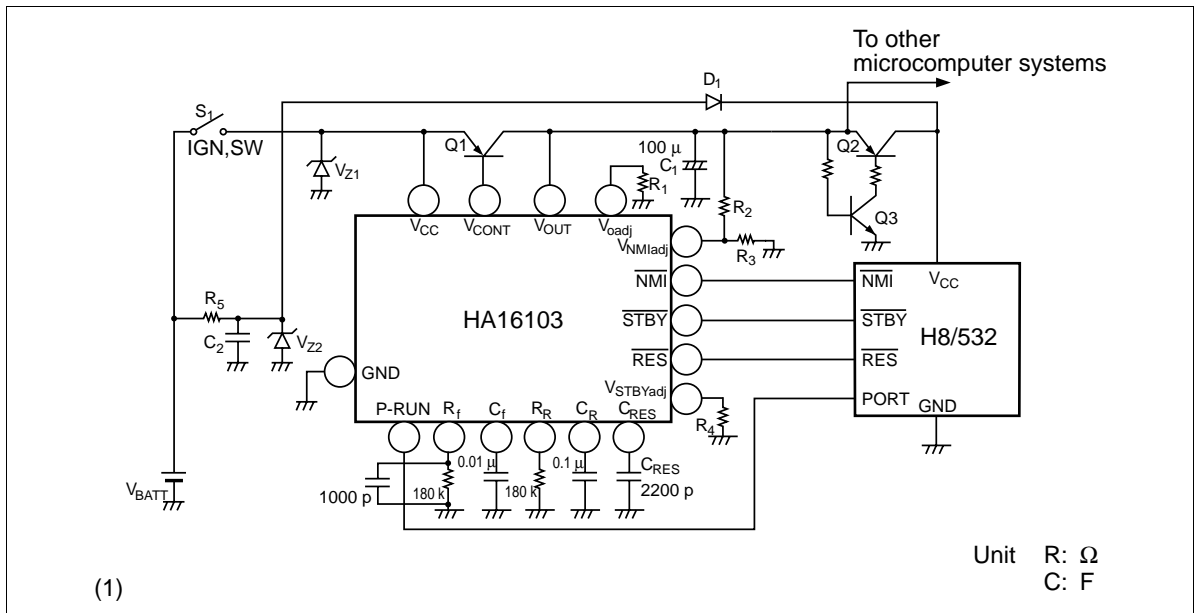

(1)

# HA16103 FPJ/FPK

## Sample Connection Circuit between HA16103 and H8/532 (2)

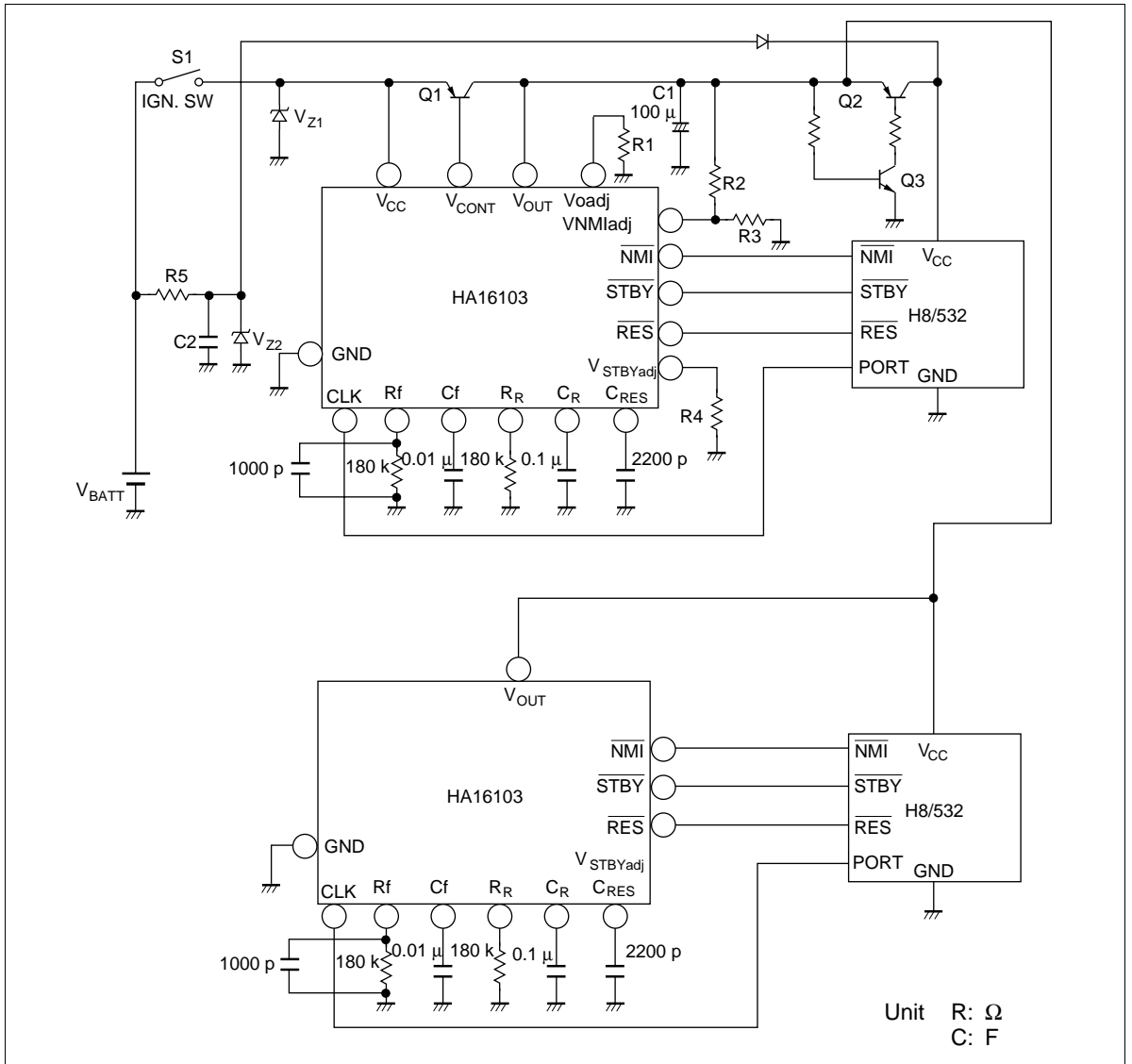

HITACHI

**Precautions**

If the IC's ground potential varies suddenly by several volts due to wiring impedance (see figure 6), a false  $\overline{\text{RES}}$  pulse may be output. The reason for this is that potentials in the  $\overline{\text{RES}}$  pulse generating circuit change together with the  $V_{\text{OUT}}\text{-GND}$  potential. The reference potential of the comparator in figure 7 and the potential of the external capacitor have different impedances as seen from the comparator, causing a momentary inversion. The solution is to stabilize the ground potential. Two ways of stabilizing the IC's ground line are:

- Separate the IC's ground line from highcurrent ground lines.
- Increase the capacitance ( $C_0$ ) used to smooth the  $V_{\text{OUT}}$  output.

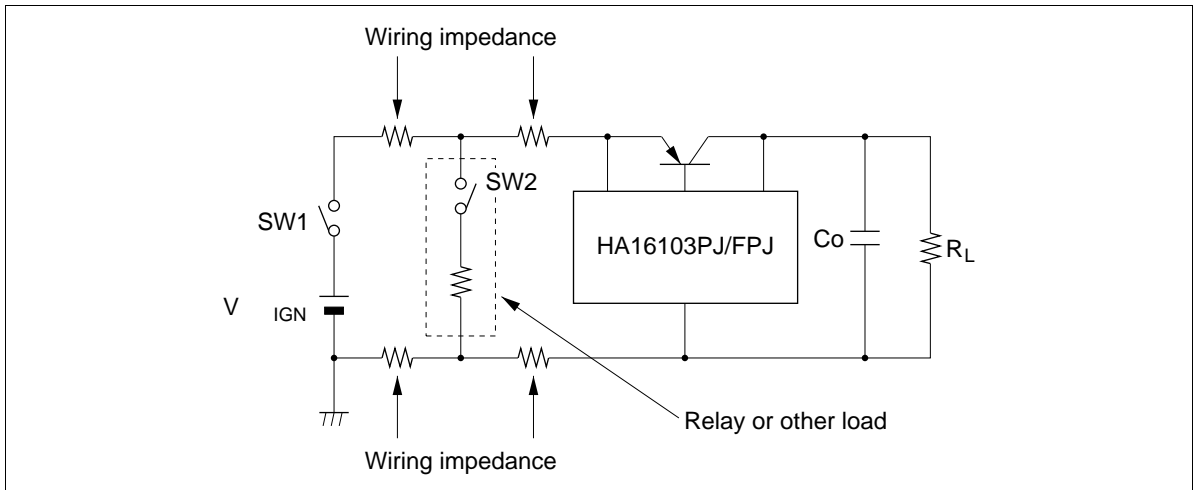

**Figure 6 Typical Circuit**

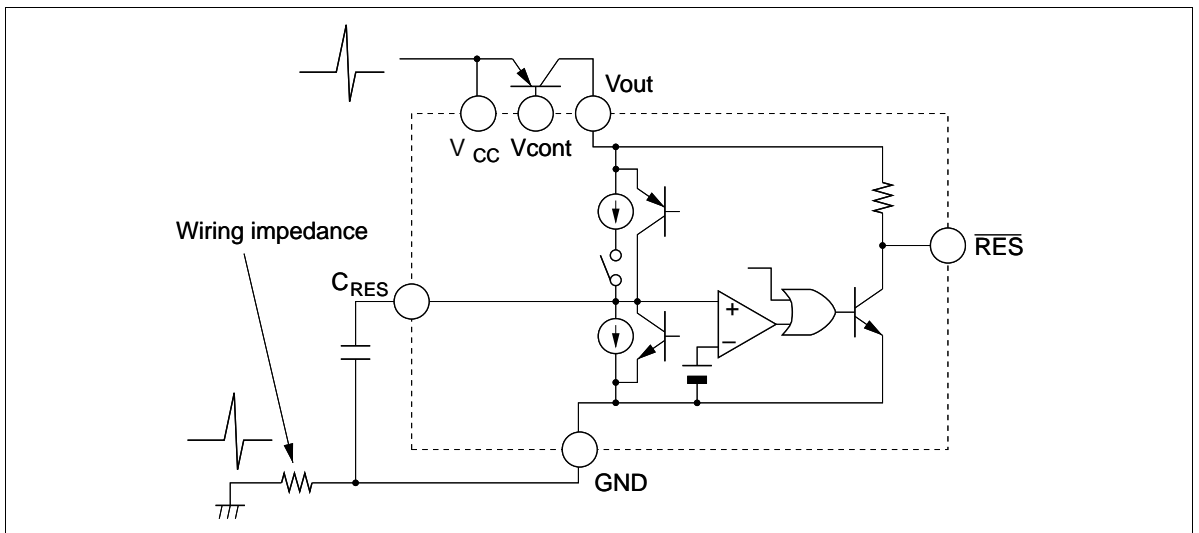

**Figure 7  $\overline{\text{RES}}$  Comparator**

• Low-voltage inhibit section

Low-Voltage Reset Pulse Delay vs.  $C_{RES}$

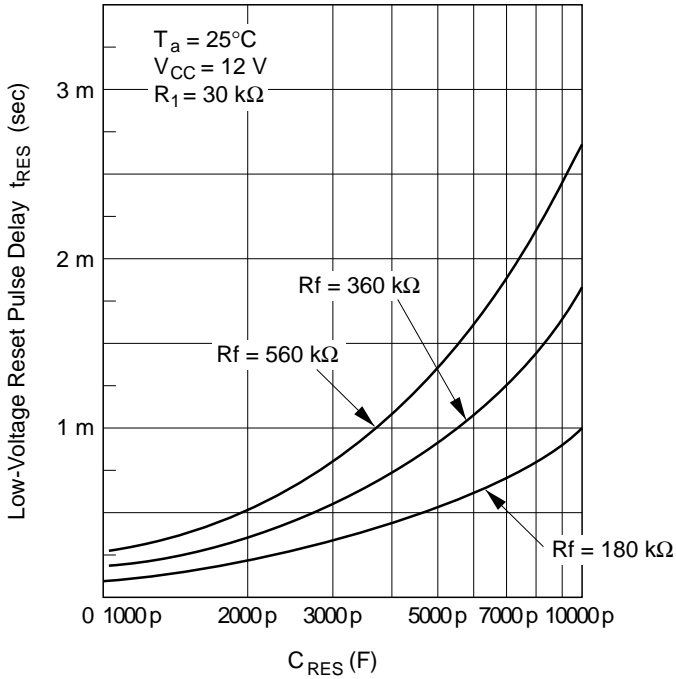

Permissible P-RUN Pulse Duty Cycle vs. P-RUN Pulse Frequency

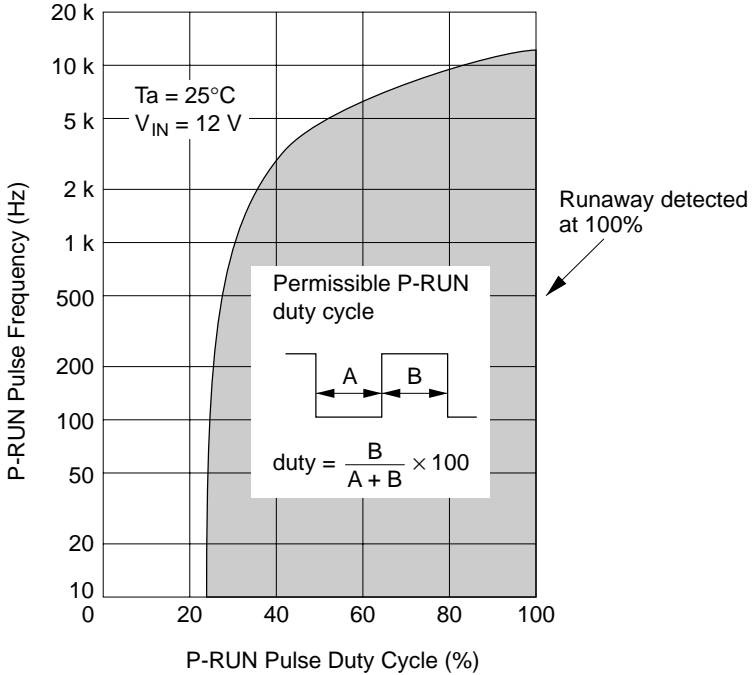

- Low-voltage inhibit section

Low-Voltage Reset Pulse Recovery Delay vs.  $C_{RES}$

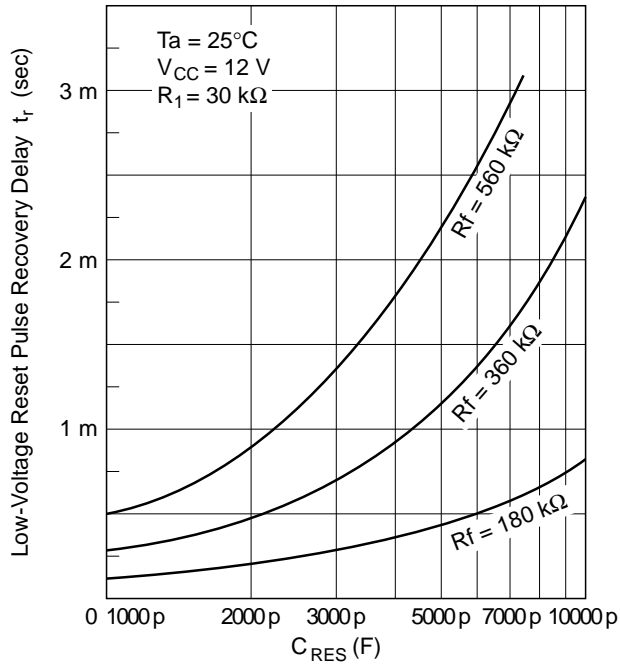

- Power-on and auto-reset section

Reset Low Time vs. Resistance  $R_R$

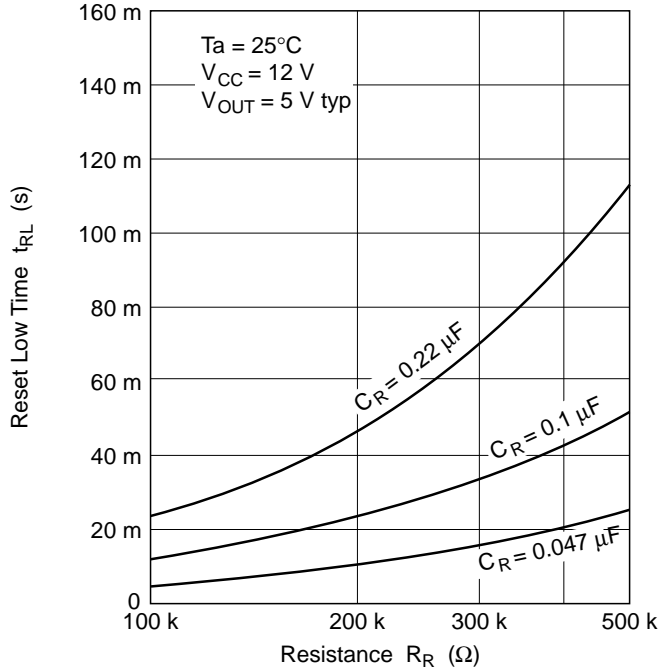

• Power-on and auto-reset section

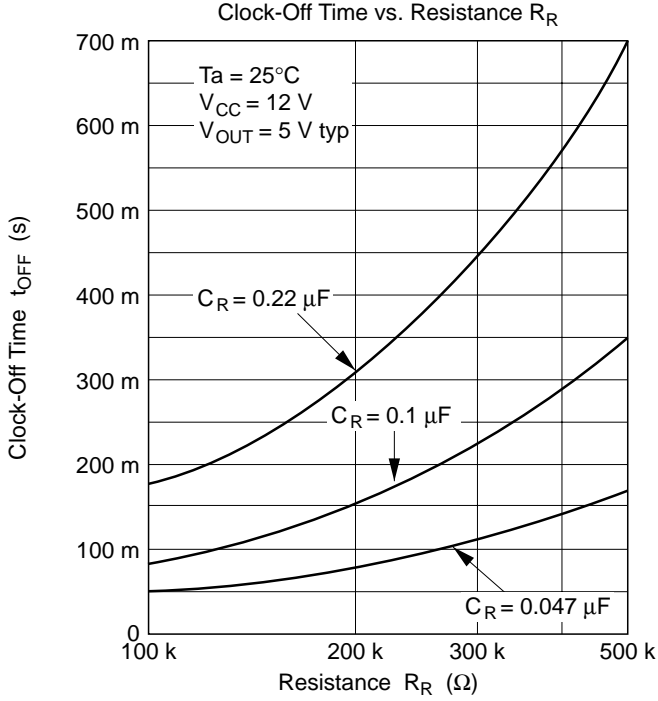

• Vref section

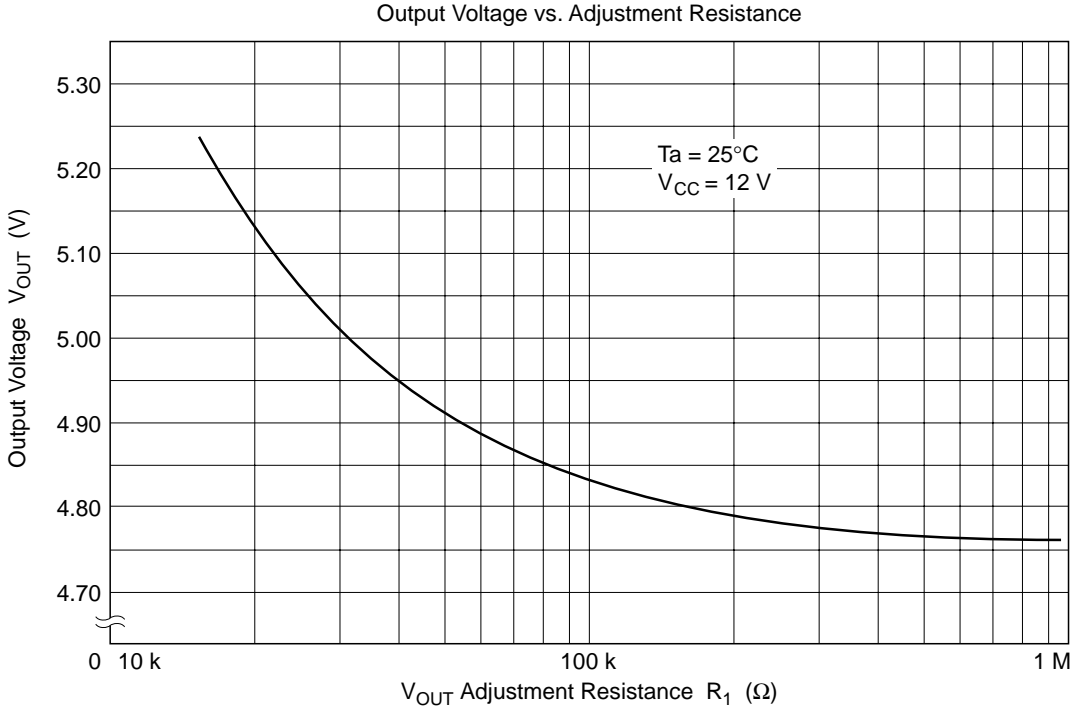

• Power-on and auto-reset section

Reset High Time vs. Resistance  $R_R$

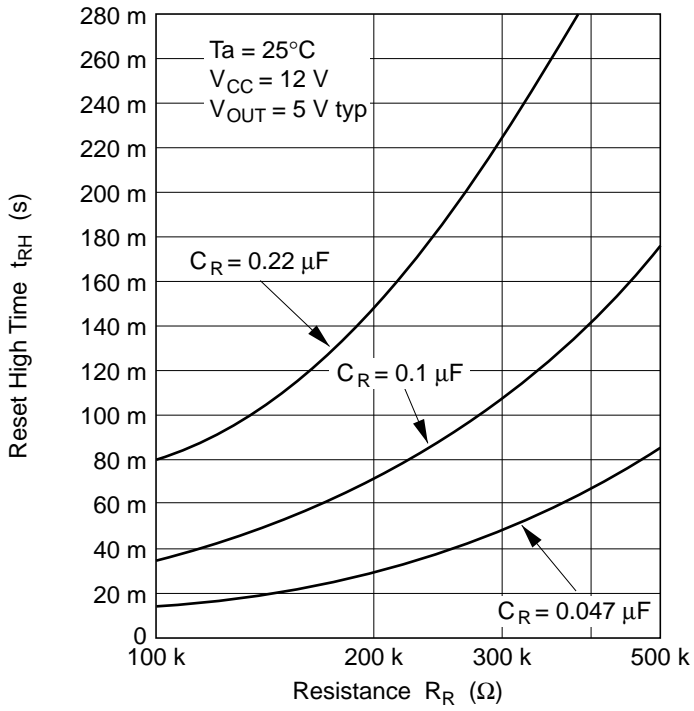

## Package Dimensions

Unit: mm

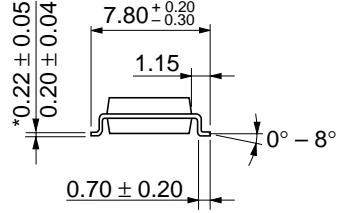
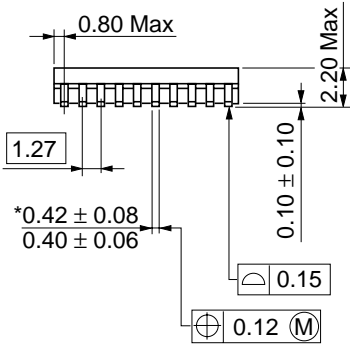
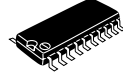
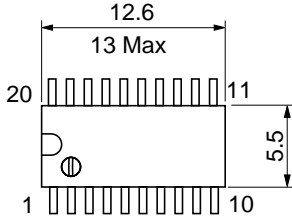

\*Dimension including the plating thickness  
Base material dimension

Hitachi Code	FP-20DA
JEDEC	—
EIAJ	Conforms
Mass (reference value)	0.31 g

**Cautions**

1. Hitachi neither warrants nor grants licenses of any rights of Hitachi's or any third party's patent, copyright, trademark, or other intellectual property rights for information contained in this document. Hitachi bears no responsibility for problems that may arise with third party's rights, including intellectual property rights, in connection with use of the information contained in this document.
2. Products and product specifications may be subject to change without notice. Confirm that you have received the latest product standards or specifications before final design, purchase or use.
3. Hitachi makes every attempt to ensure that its products are of high quality and reliability. However, contact Hitachi's sales office before using the product in an application that demands especially high quality and reliability or where its failure or malfunction may directly threaten human life or cause risk of bodily injury, such as aerospace, aeronautics, nuclear power, combustion control, transportation, traffic, safety equipment or medical equipment for life support.
4. Design your application so that the product is used within the ranges guaranteed by Hitachi particularly for maximum rating, operating supply voltage range, heat radiation characteristics, installation conditions and other characteristics. Hitachi bears no responsibility for failure or damage when used beyond the guaranteed ranges. Even within the guaranteed ranges, consider normally foreseeable failure rates or failure modes in semiconductor devices and employ systemic measures such as fail-safes, so that the equipment incorporating Hitachi product does not cause bodily injury, fire or other consequential damage due to operation of the Hitachi product.
5. This product is not designed to be radiation resistant.
6. No one is permitted to reproduce or duplicate, in any form, the whole or part of this document without written approval from Hitachi.
7. Contact Hitachi's sales office for any questions regarding this document or Hitachi semiconductor products.

# HITACHI

**Hitachi, Ltd.**

Semiconductor & Integrated Circuits.  
 Nippon Bldg., 2-6-2, Ohite-machi, Chiyoda-ku, Tokyo 100-0004, Japan  
 Tel: Tokyo (03) 3270-2111 Fax: (03) 3270-5109

URL      NorthAmerica      : <http://semiconductor.hitachi.com/>  
          Europe                 : <http://www.hitachi-eu.com/hel/ecg>  
          Asia (Singapore)     : <http://www.has.hitachi.com.sg/grp3/sicd/index.htm>  
          Asia (Taiwan)         : [http://www.hitachi.com.tw/E/Product/SICD\\_Frame.htm](http://www.hitachi.com.tw/E/Product/SICD_Frame.htm)  
          Asia (HongKong)      : <http://www.hitachi.com.hk/eng/bo/grp3/index.htm>  
          Japan                     : <http://www.hitachi.co.jp/Sicd/indx.htm>

**For further information write to:**

<p>Hitachi Semiconductor (America) Inc.                  179 East Tasman Drive, San Jose, CA 95134                  Tel: &lt;1&gt; (408) 433-1990                  Fax: &lt;1&gt; (408) 433-0223</p>	<p>Hitachi Europe GmbH                  Electronic components Group                  Dornacher Straße 3                  D-85622 Feldkirchen, Munich                  Germany                  Tel: &lt;49&gt; (89) 9 9180-0                  Fax: &lt;49&gt; (89) 9 29 30 00</p> <p>Hitachi Europe Ltd.                  Electronic Components Group.                  Whitebrook Park                  Lower Cookham Road                  Maidenhead                  Berkshire SL6 8YA, United Kingdom                  Tel: &lt;44&gt; (1628) 585000                  Fax: &lt;44&gt; (1628) 778322</p>	<p>Hitachi Asia Pte. Ltd.                  16 Collyer Quay #20-00                  Hitachi Tower                  Singapore 049318                  Tel: 535-2100                  Fax: 535-1533</p> <p>Hitachi Asia Ltd.                  Taipei Branch Office                  3F, Hung Kuo Building, No.167,                  Tun-Hwa North Road, Taipei (105)                  Tel: &lt;886&gt; (2) 2718-3666                  Fax: &lt;886&gt; (2) 2718-8180</p>	<p>Hitachi Asia (Hong Kong) Ltd.                  Group III (Electronic Components)                  7/F., North Tower, World Finance Centre,                  Harbour City, Canton Road, Tsim Sha Tsui,                  Kowloon, Hong Kong                  Tel: &lt;852&gt; (2) 735 9218                  Fax: &lt;852&gt; (2) 730 0281                  Telex: 40815 HITEC HX</p>
--	--	---	---

Copyright ' Hitachi, Ltd., 1998. All rights reserved. Printed in Japan.



LittleDiode supplies new, hard to find or obsolete electronic components and semiconductors all over the world.

With over two million different components listed you are sure to find the part you need.

Feel free to visit us today at our online store:

[LittleDiode.com](http://LittleDiode.com)

Looking forward to providing you with the best possible service.