

**30MHz, Voltage Output, Two Quadrant Analog Multiplier**

The HA-2546 is a monolithic, high speed, two quadrant, analog multiplier constructed in the Intersil Dielectrically Isolated High Frequency Process. The HA-2546 has a voltage output with a 30MHz signal bandwidth, 300V/ $\mu$ s slew rate and a 17MHz control bandwidth. High bandwidth and slew rate make this part an ideal component for use in video systems. The suitability for precision video applications is demonstrated further by the 0.1dB gain flatness to 5MHz, 1.6% multiplication error, -52dB feedthrough and differential inputs with 1.2 $\mu$ A bias currents. The HA-2546 also has low differential gain (0.1%) and phase (0.1 degree) errors.

The HA-2546 is well suited for AGC circuits as well as mixer applications for sonar, radar, and medical imaging equipment. The voltage output simplifies many designs by eliminating the current to voltage conversion stage required for current output multipliers. For MIL-STD-883 compliant product, consult the HA-2546/883 datasheet.

**Pinout**

**HA-2546  
(PDIP, CERDIP, SOIC)  
TOP VIEW**

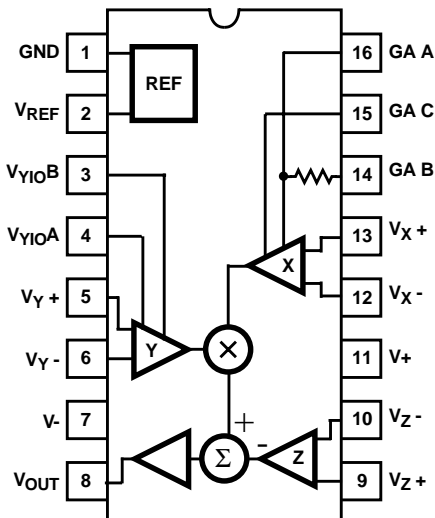

**Features**

- High Speed Voltage Output . . . . . 300V/ $\mu$ s
- Low Multiplication error . . . . . 1.6%
- Input Bias Currents . . . . . 1.2 $\mu$ A
- Signal Input Feedthrough . . . . . -52dB
- Wide Signal Bandwidth . . . . . 30MHz
- Wide Control Bandwidth . . . . . 17MHz
- Gain Flatness to 5MHz . . . . . 0.10dB

**Applications**

- Military Avionics
- Missile Guidance Systems
- Medical Imaging Displays
- Video Mixers
- Sonar AGC Processors
- Radar Signal Conditioning
- Voltage Controlled Amplifier
- Vector Generator

**Ordering Information**

PART NUMBER	TEMP. RANGE (°C)	PACKAGE	PKG. NO.
HA1-2546-5	0 to 75	16 Ld CERDIP	F16.3
HA3-2546-5	0 to 75	16 Ld PDIP	E16.3
HA9P2546-5	0 to 65	16 Ld SOIC	M16.3

Simplified Schematic

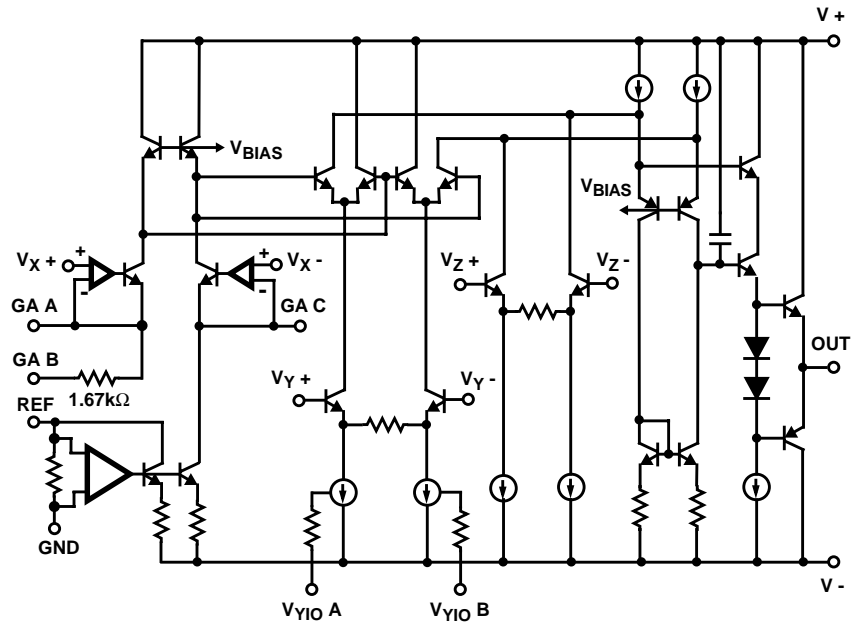

**Absolute Maximum Ratings**

Voltage Between V+ and V- .....	35V
Differential Input Voltage .....	6V
Output Current .....	±60mA

**Operating Conditions**

Temperature Range	
HA3-2546-5, HA1-2546-5 .....	0°C to 75°C
HA9P2546-5 .....	0°C to 65°C

**Thermal Information**

Thermal Resistance (Typical, Note 1)	$\theta_{JA}$ (°C/W)	$\theta_{JC}$ (°C/W)
CERDIP Package .....	75	20
PDIP Package .....	86	N/A
SOIC Package .....	96	N/A
Maximum Junction Temperature (CERDIP Package) .....	175°C	
Maximum Junction Temperature (Plastic Package) .....	150°C	
Maximum Storage Temperature Range .....	-65°C to 150°C	
Maximum Lead Temperature (Soldering 10s) .....	300°C (SOIC - Lead Tips Only)	

CAUTION: Stresses above those listed in "Absolute Maximum Ratings" may cause permanent damage to the device. This is a stress only rating and operation of the device at these or any other conditions above those indicated in the operational sections of this specification is not implied.

NOTES:

1.  $\theta_{JA}$  is measured with the component mounted on an evaluation PC board in free air.

**Electrical Specifications**  $V_{SUPPLY} = \pm 15V, R_L = 1k\Omega, C_L = 50pF$ , Unless Otherwise Specified

PARAMETER	TEST CONDITIONS	TEMP (°C)	MIN	TYP	MAX	UNITS
<b>MULTIPLIER PERFORMANCE</b>						
Multiplication Error (Note 2)		25	-	1.6	3	%
		Full	-	3.0	7	%
Multiplication Error Drift		Full	-	0.003	-	%/°C
Differential Gain (Notes 3, 9)		25	-	0.1	0.2	%
Differential Phase (Notes 3, 9)		25	-	0.1	0.3	Degrees
Gain Flatness (Note 9)	DC to 5MHz, $V_X = 2V$	25	-	0.1	0.2	dB
	5 MHz to 8MHz, $V_X = 2V$	25	-	0.18	0.3	dB
Scale Factor Error		Full	-	0.7	5.0	%
1% Amplitude Bandwidth Error		25	-	6	-	MHz
1% Vector Bandwidth Error		25	-	260	-	kHz
THD + N (Note 4)		25	-	0.03	-	%
Voltage Noise	$f_O = 10Hz, V_X = V_Y = 0V$	25	-	400	-	nV/√Hz
	$f_O = 100Hz, V_X = V_Y = 0V$	25	-	150	-	nV/√Hz
	$f_O = 1kHz, V_X = V_Y = 0V$	25	-	75	-	nV/√Hz
Common Mode Range		25	-	±9	-	V
<b>SIGNAL INPUT, <math>V_Y</math></b>						
Input Offset Voltage		25	-	3	10	mV
		Full	-	8	20	mV
Average Offset Voltage Drift		Full	-	45	-	μV/°C
Input Bias Current		25	-	7	15	μA
		Full	-	10	15	μA
Input Offset Current		25	-	0.7	2	μA
		Full	-	1.0	3	μA
Input Capacitance		25	-	2.5	-	pF
Differential Input Resistance		25	-	720	-	kΩ
Small Signal Bandwidth (-3dB)	$V_X = 2V$	25	-	30	-	MHz
Full Power Bandwidth (Note 5)	$V_X = 2V$	25	-	9.5	-	MHz
Feedthrough	Note 11	25	-	-52	-	dB
CMRR	Note 6	Full	60	78	-	dB
<b><math>V_Y</math> TRANSIENT RESPONSE (Note 10)</b>						
Slew Rate	$V_{OUT} = \pm 5V, V_X = 2V$	25	-	300	-	V/μs
Rise Time	Note 7	25	-	11	-	ns

**Electrical Specifications**  $V_{\text{SUPPLY}} = \pm 15\text{V}$ ,  $R_L = 1\text{k}\Omega$ ,  $C_L = 50\text{pF}$ , Unless Otherwise Specified (Continued)

PARAMETER	TEST CONDITIONS	TEMP (°C)	MIN	TYP	MAX	UNITS
Overshoot	Note 7	25	-	17	-	%
Propagation Delay		25	-	25	-	ns
Settling Time (To 0.1%)	$V_{\text{OUT}} = \pm 5\text{V}$ , $V_X = 2\text{V}$	25	-	200	-	ns
<b>CONTROL INPUT, <math>V_X</math></b>						
Input Offset Voltage		25	-	0.3	2	mV
		Full	-	3	20	mV
Average Offset Voltage Drift		Full	-	10	-	$\mu\text{V}/^\circ\text{C}$
Input Bias Current		25	-	1.2	2	$\mu\text{A}$
		Full	-	1.8	5	$\mu\text{A}$
Input Offset Current		25	-	0.3	2	$\mu\text{A}$
		Full	-	0.4	3	$\mu\text{A}$
Input Capacitance		25	-	2.5	-	pF
Differential Input Resistance		25	-	360	-	k $\Omega$
Small Signal Bandwidth (-3dB)	$V_Y = 5\text{V}$ , $V_X = -1\text{V}$	25	-	17	-	MHz
Feedthrough	Note 12	25	-	-40	-	dB
Common Mode Rejection Ratio	Note 13	25	-	80	-	dB
<b><math>V_X</math> TRANSIENT RESPONSE (Note 10)</b>						
Slew Rate	Note 13	25	-	95	-	V/ $\mu\text{s}$
Rise Time	Note 14	25	-	20	-	ns
Overshoot	Note 14	25	-	17	-	%
Propagation Delay		25	-	50	-	ns
Settling Time (To 0.1%)	Note 13	25	-	200	-	ns
<b><math>V_Z</math> CHARACTERISTICS</b>						
Input Offset Voltage	$V_X = V_Y = 0\text{V}$	25	-	4	15	mV
		Full	-	8	20	mV
Open Loop Gain		25	-	70	-	dB
Differential Input Resistance		25	-	900	-	k $\Omega$
<b>OUTPUT CHARACTERISTICS</b>						
Output Voltage Swing	$V_X = 2.5\text{V}$ , $V_Y = \pm 5\text{V}$	Full	-	$\pm 6.25$	-	V
Output Current		Full	$\pm 20$	$\pm 45$	-	mA
Output Resistance		25	-	1	-	$\Omega$
<b>POWER SUPPLY</b>						
PSRR	Note 8	Full	58	63	-	dB
Supply Current		Full	-	23	29	mA

## NOTES:

- Error is percent of full scale, 1% = 50mV.
- $f_O = 3.58\text{MHz}/4.43\text{MHz}$ ,  $V_Y = 300\text{mV}_{\text{P-P}}$ , 0 to 1V<sub>DC</sub> offset,  $V_X = 2\text{V}$ .
- $f_O = 10\text{kHz}$ ,  $V_Y = 1\text{V}_{\text{RMS}}$ ,  $V_X = 2\text{V}$ .
- Full Power Bandwidth calculated by equation:  $\text{FPBW} = \frac{\text{Slew Rate}}{2\pi V_{\text{PEAK}}}$ ,  $V_{\text{PEAK}} = 5\text{V}$ .
- $V_Y = 0$  to  $\pm 5\text{V}$ ,  $V_X = 2\text{V}$ .
- $V_{\text{OUT}} = 0$  to  $\pm 100\text{mV}$ ,  $V_X = 2\text{V}$ .
- $V_S = \pm 12\text{V}$  to  $\pm 15\text{V}$ ,  $V_Y = 5\text{V}$ ,  $V_X = 2\text{V}$ .
- Guaranteed by characterization and not 100% tested.
- See Test Circuit.
- $f_O = 5\text{MHz}$ ,  $V_X = 0$ ,  $V_Y = 200\text{mV}_{\text{RMS}}$ .
- $f_O = 100\text{kHz}$ ,  $V_Y = 0$ ,  $V_{X+} = 200\text{mV}_{\text{RMS}}$ ,  $V_{X-} = -0.5\text{V}$ .
- $V_X = 0$  to  $2\text{V}$ ,  $V_Y = 5\text{V}$ .
- $V_X = 0$  to  $200\text{mV}$ ,  $V_Y = 5\text{V}$ .

Test Circuits and Waveforms

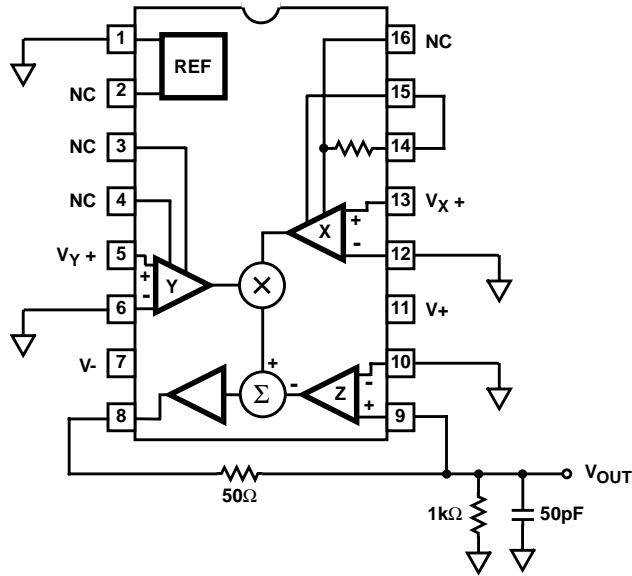
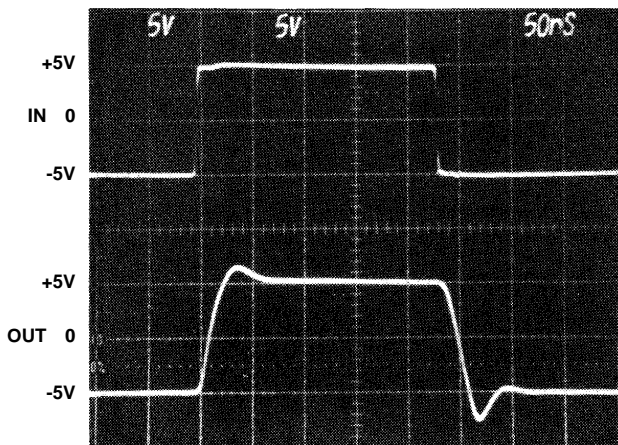
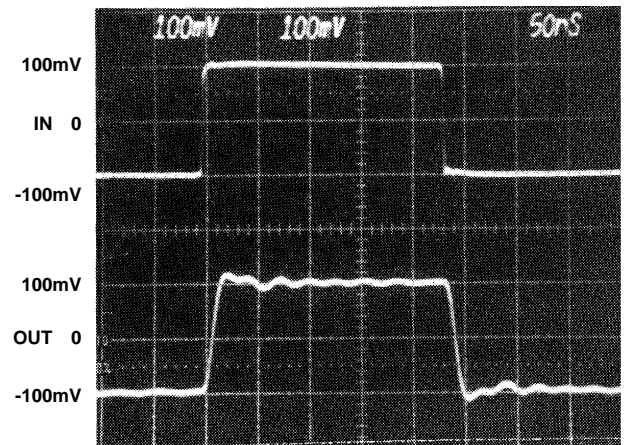

FIGURE 1. LARGE AND SMALL SIGNAL RESPONSE TEST CIRCUIT



Vertical Scale: 5V/Div.; Horizontal Scale: 50ns/Div.  
**V<sub>Y</sub> LARGE SIGNAL RESPONSE**



Vertical Scale: 100mV/Div.; Horizontal Scale: 50ns/Div.  
**V<sub>Y</sub> SMALL SIGNAL RESPONSE**

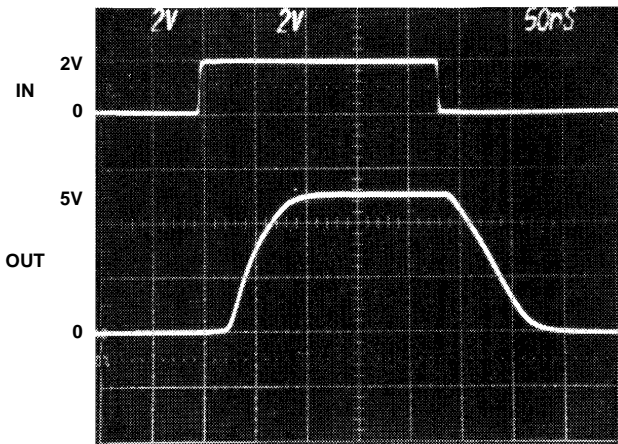

Vertical Scale: 2V/Div.; Horizontal Scale: 50ns/Div.  
**V<sub>X</sub> LARGE SIGNAL RESPONSE**

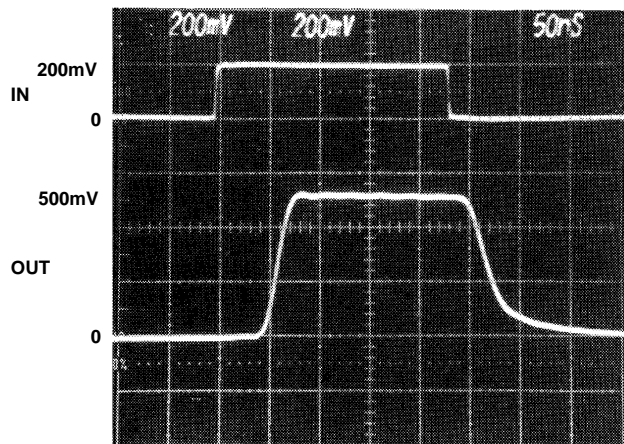

Vertical Scale: 200mV/Div.; Horizontal Scale: 50ns/Div.  
**V<sub>X</sub> SMALL SIGNAL RESPONSE**

## Application Information

### Theory Of Operation

The HA-2546 is a two quadrant multiplier with the following three differential inputs; the signal channel,  $V_{Y+}$  and  $V_{Y-}$ , the control channel,  $V_{X+}$  and  $V_{X-}$ , and the summed channel,  $V_{Z+}$  and  $V_{Z-}$ , to complete the feedback of the output amplifier. The differential voltages of channel X and Y are converted to differential currents. These currents are then multiplied in a circuit similar to a Gilbert Cell multiplier, producing a differential current product. The differential voltage of the Z channel is converted into a differential current which then sums with the products currents. The differential "product/sum" currents are converted to a single-ended current and then converted to a voltage output by a transimpedance amplifier.

The open loop transfer equation for the HA-2546 is:

$$V_{OUT} = A \left[ \frac{(V_{X+} - V_{X-})(V_{Y+} - V_{Y-})}{SF} - (V_{Z+} - V_{Z-}) \right]$$

where; A = Output Amplifier Open Loop Gain  
 SF = Scale Factor  
 $V_X$ ,  $V_Y$ ,  $V_Z$  = Differential Inputs

The scale factor is used to maintain the output of the multiplier within the normal operating range of  $\pm 5V$ . The scale factor can be defined by the user by way of an optional external resistor,  $R_{EXT}$ , and the Gain Adjust pins, Gain Adjust A (GA A), Gain Adjust B (GA B), and Gain Adjust C (GA C). The scale factor is determined as follows:

- SF = 2, when GA B is shorted to GA C
- SF  $\cong$  1.2  $R_{EXT}$ , when  $R_{EXT}$  is connected between GA A and GA C ( $R_{EXT}$  is in  $k\Omega$ )
- SF  $\cong$  1.2 ( $R_{EXT} + 1.667k\Omega$ ), when  $R_{EXT}$  is connected to GA B and GA C ( $R_{EXT}$  is in  $k\Omega$ )

The scale factor can be adjusted from 2 to 5. It should be noted that any adjustments to the scale factor will affect the AC performance of the control channel,  $V_X$ . The normal input operating range of  $V_X$  is equal to the scale factor voltage.

The typical multiplier configuration is shown in Figure 2. The ideal transfer function for this configuration is:

$$V_{OUT} = \begin{cases} \frac{(V_{X+} - V_{X-})(V_{Y+} - V_{Y-})}{2} + V_{Z-}, & \text{when } V_X \geq 0V \\ 0, & \text{when } V_X < 0V \end{cases}$$

The  $V_{X-}$  pin is usually connected to ground so that when  $V_{X+}$  is negative there is no signal at the output, i.e. two quadrant operation. If the  $V_X$  input is a negative going signal the  $V_{X+}$  pin maybe grounded and the  $V_{X-}$  pin used as the control input.

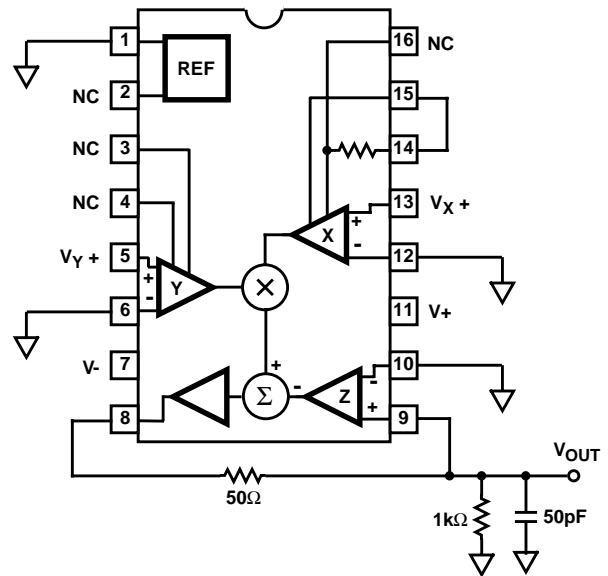

FIGURE 2.

The  $V_{Y-}$  terminal is usually grounded allowing the  $V_{Y+}$  to swing  $\pm 5V$ . The  $V_{Z+}$  terminal is usually connected directly to  $V_{OUT}$  to complete the feedback loop of the output amplifier while  $V_{Z-}$  is grounded. The scale factor is normally set to 2 by connecting GA B to GA C. Therefore the transfer equation simplifies to  $V_{OUT} = (V_X V_Y) / 2$ .

### Offset Adjustment

The signal channel offset voltage may be nulled by using a 20k $\Omega$  potentiometer between  $V_{YIO}$  Adjust pins A and B and connecting the wiper to  $V_{-}$ . Reducing the signal channel offset will reduce  $V_X$  AC feedthrough. Output offset voltage can also be nulled by connecting  $V_{Z-}$  to the wiper of a 20k $\Omega$  potentiometer which is tied between  $V_{+}$  and  $V_{-}$ .

### Capacitive Drive Capability

When driving capacitive loads  $>20pF$ , a 50 $\Omega$  resistor is recommended between  $V_{OUT}$  and  $V_{Z+}$ , using  $V_{Z+}$  as the output (see Figure 2). This will prevent the multiplier from going unstable.

### Power Supply Decoupling

Power supply decoupling is essential for high frequency circuits. A 0.01 $\mu F$  high quality ceramic capacitor at each supply pin in parallel with a 1 $\mu F$  tantalum capacitor will provide excellent decoupling. Chip capacitors produce the best results due to the close spacing with which they may be placed to the supply pins minimizing lead inductance.

### Adjusting Scale Factor

Adjusting the scale factor will tailor the control signal,  $V_X$ , input voltage range to match your needs. Referring to the simplified schematic on the front page and looking for the  $V_X$  input stage, you will notice the unusual design. The internal reference sets up a 1.2mA current sink for the  $V_X$  differential pair. The control signal applied to this input will be forced across the scale factor setting resistor and set the current flowing in the  $V_{X+}$  side of the differential pair. When the

current through this resistor reaches 1.2mA, all the current available is flowing in the one side and full scale has been reached. Normally the 1.67kΩ internal resistor sets the scale factor to 2V when the Gain Adjust pins B and C are connected together, but you may set this resistor to any convenient value using pins 16 (GA A) and 15 (GA C) (See Figure 3).

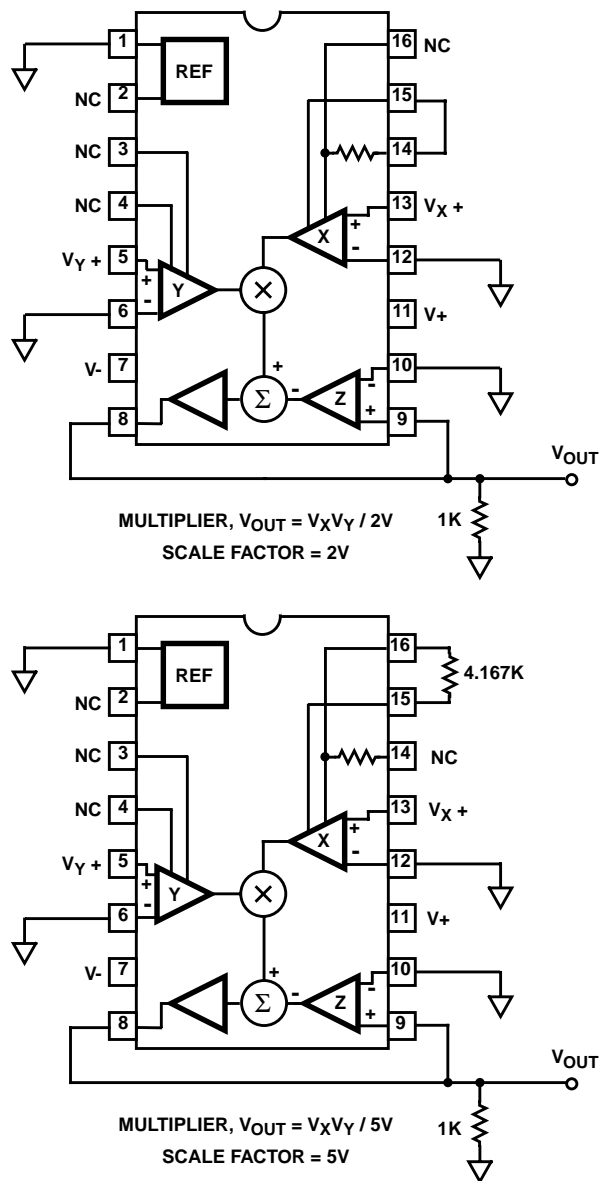

FIGURE 3. SETTING THE SCALE FACTOR

## Typical Applications

### Automatic Gain Control

In Figure 4 the HA-2546 is configured in a true Automatic Gain Control or AGC application. The HA-5127, low noise op amp, provides the gain control level to the X input. This level will set the peak output voltage of the multiplier to match the reference level. The feedback network around the HA-5127

provides stability and a response time adjustment for the gain control circuit.

This multiplier has the advantage over other AGC circuits, in that the signal bandwidth is not affected by the control signal gain adjustment.

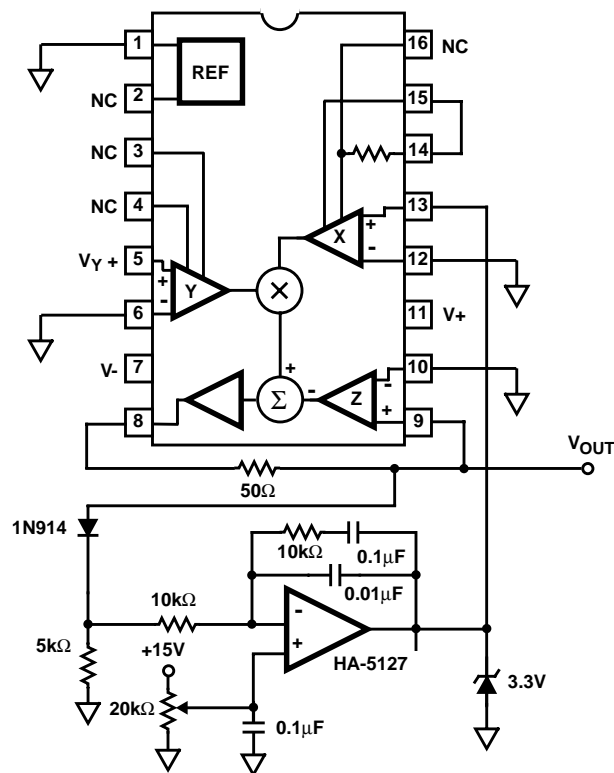

FIGURE 4. AUTOMATIC GAIN CONTROL

### Voltage Controlled Amplifier

A wide range of gain adjustment is available with the Voltage Controlled Amplifier configuration shown in Figure 5. Here the gain of the HFA0002 is swept from 20V/V at a control voltage of 0.902V to a gain of almost 1000V/V with a control voltage of 0.03V.

### Video Fader

The Video Fader circuit provides a unique function. Here Ch B is applied to the minus Z input in addition to the minus Y input. In this way, the function in Figure 6 is generated.  $V_{MIX}$  will control the percentage of Ch A and Ch B that are mixed together to produce a resulting video image or other signal.

Many other applications are possible including division, squaring, square-root, percentage calculations, etc. Please refer to the HA-2556 four quadrant multiplier data sheet for additional applications.

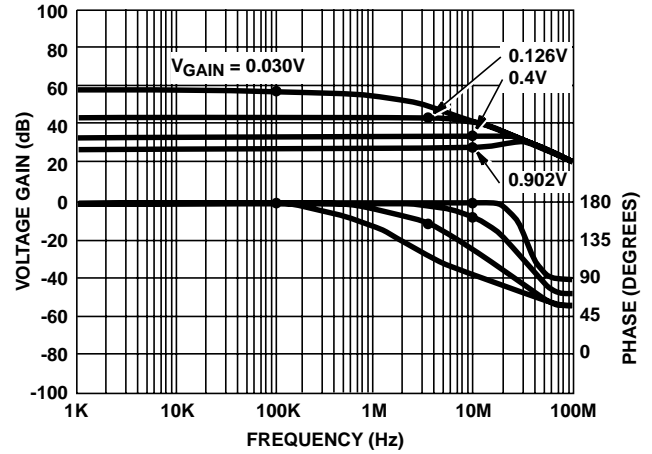
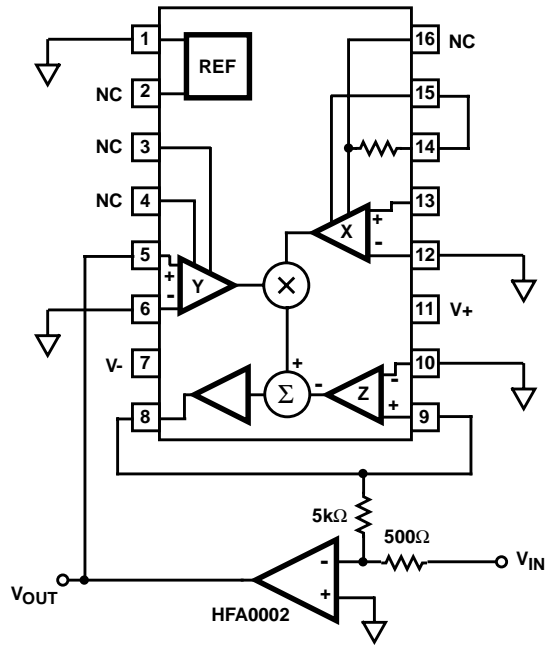
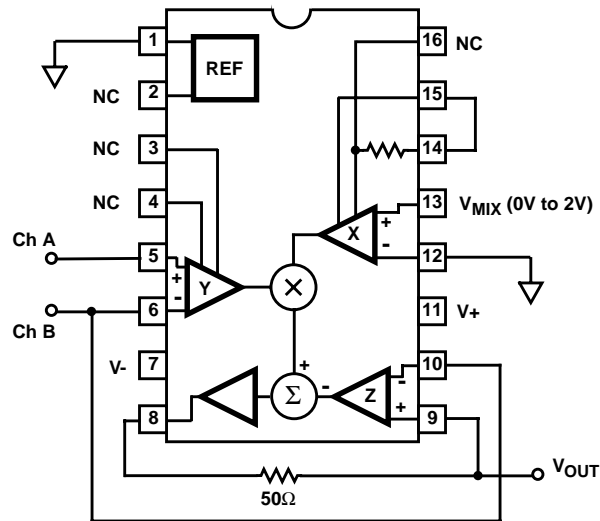

FIGURE 5. VOLTAGE CONTROLLED AMPLIFIER



$$V_{OUT} = \text{Ch B} + (\text{Ch A} - \text{Ch B}) V_{MIX} / \text{Scale Factor}$$

Scale Factor = 2

$V_{OUT}$  = All Ch B; if  $V_{MIX} = 0V$

$V_{OUT}$  = All Ch A; if  $V_{MIX} = 2V$  (Full Scale)

$V_{OUT}$  = Mix of Ch A and Ch B; if  $0V < V_{MIX} < 2V$

FIGURE 6. VIDEO FADER

**Typical Performance Curves**  $V_S = \pm 15V$ ,  $T_A = 25^\circ C$ , See Test Circuit For Multiplier Configuration

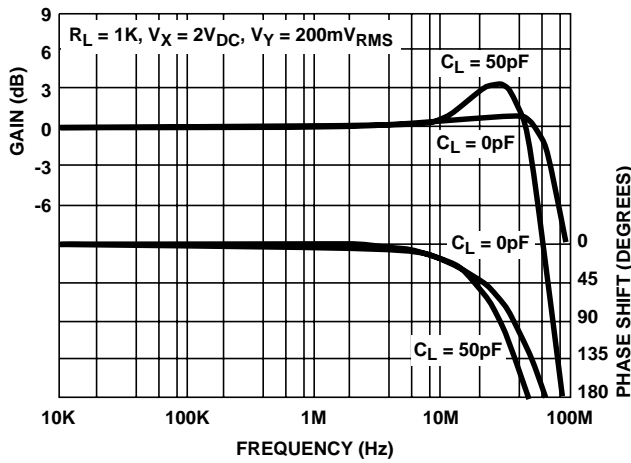

FIGURE 7.  $V_Y$  GAIN AND PHASE vs FREQUENCY

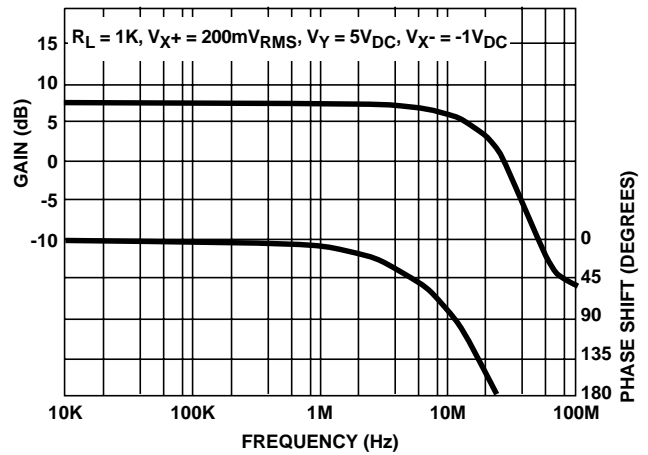

FIGURE 8.  $V_X$  GAIN AND PHASE vs FREQUENCY

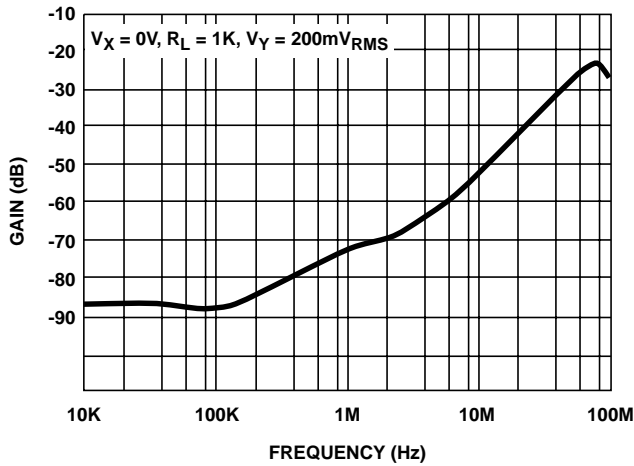

FIGURE 9.  $V_Y$  FEEDTHROUGH vs FREQUENCY

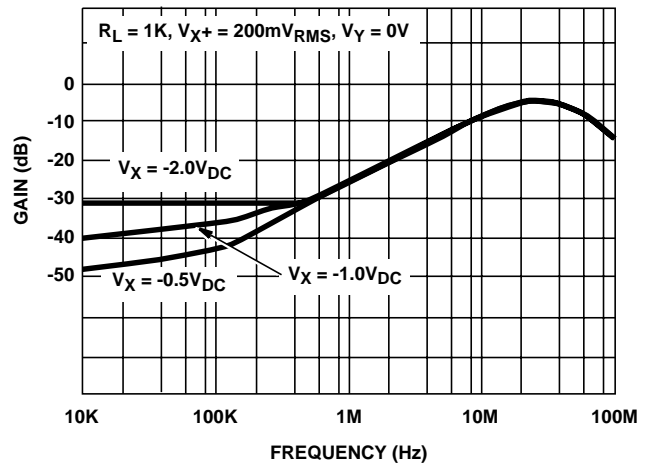

FIGURE 10.  $V_X$  FEEDTHROUGH vs FREQUENCY

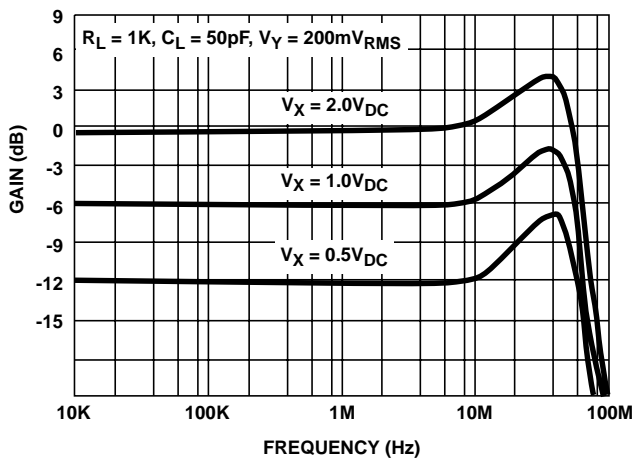

FIGURE 11. VARIOUS  $V_Y$  FREQUENCY RESPONSES

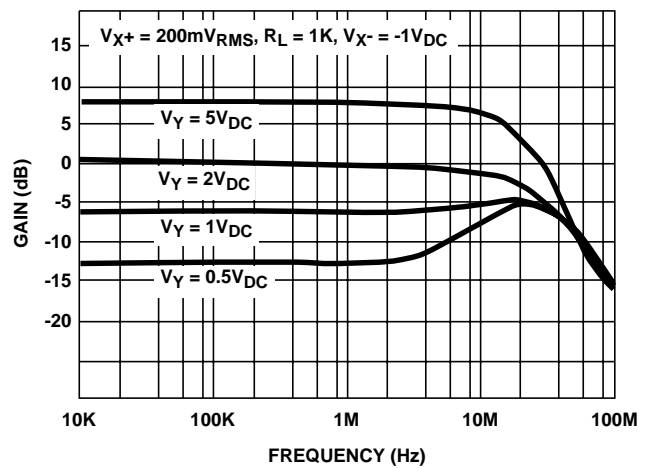

FIGURE 12. VARIOUS  $V_X$  FREQUENCY RESPONSES

**Typical Performance Curves**  $V_S = \pm 15V$ ,  $T_A = 25^\circ C$ , See Test Circuit For Multiplier Configuration (Continued)

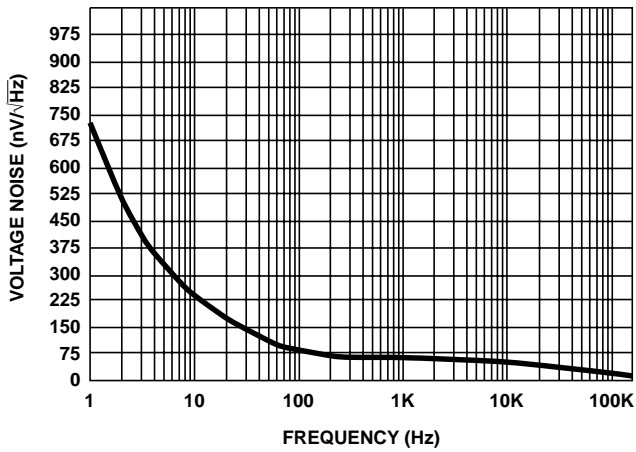

FIGURE 13. VOLTAGE NOISE DENSITY

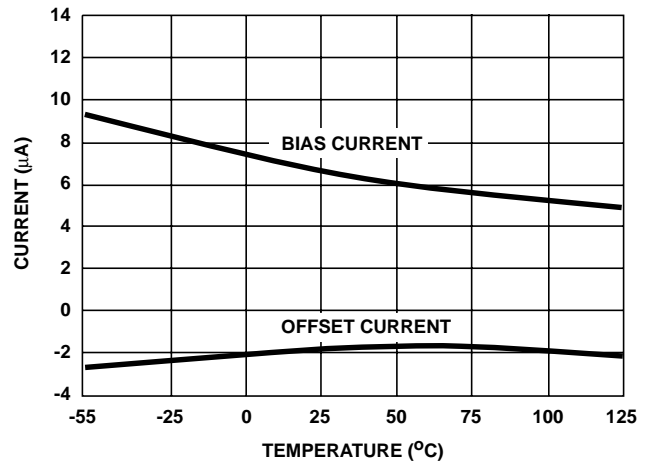

FIGURE 14.  $V_\gamma$  OFFSET AND BIAS CURRENT vs TEMPERATURE

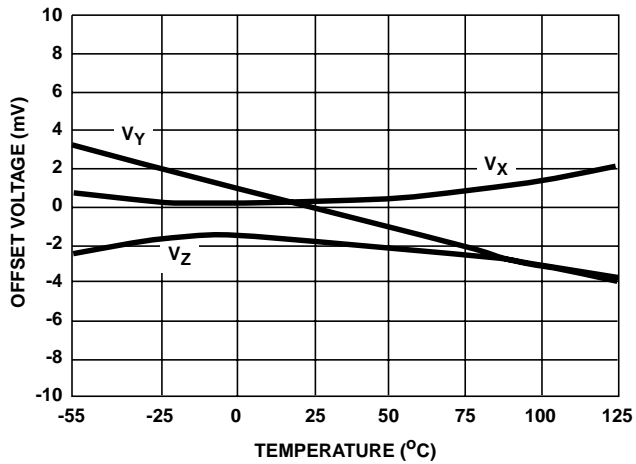

FIGURE 15. OFFSET VOLTAGE vs TEMPERATURE

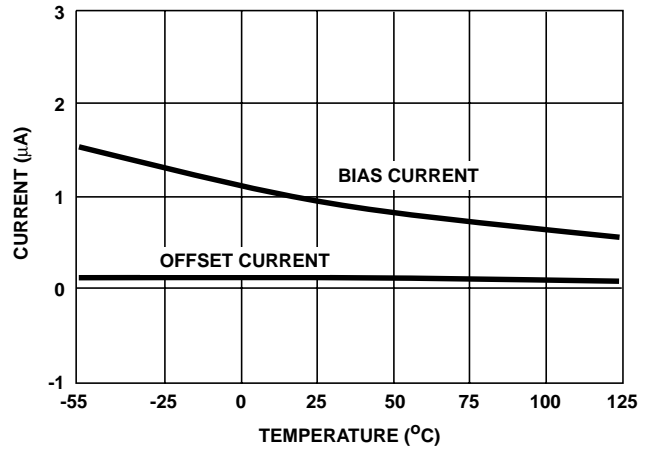

FIGURE 16.  $V_x$  OFFSET AND BIAS CURRENT vs TEMPERATURE

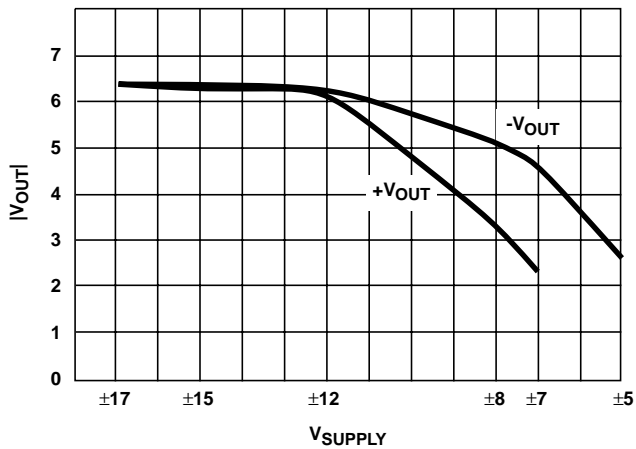

FIGURE 17.  $V_{OUT}$  vs  $V_{SUPPLY}$

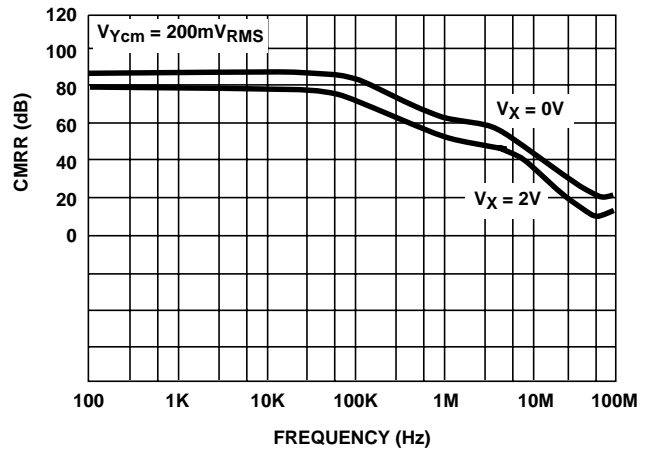

FIGURE 18.  $V_\gamma$  CMRR vs FREQUENCY

**Typical Performance Curves**  $V_S = \pm 15V$ ,  $T_A = 25^\circ C$ , See Test Circuit For Multiplier Configuration (Continued)

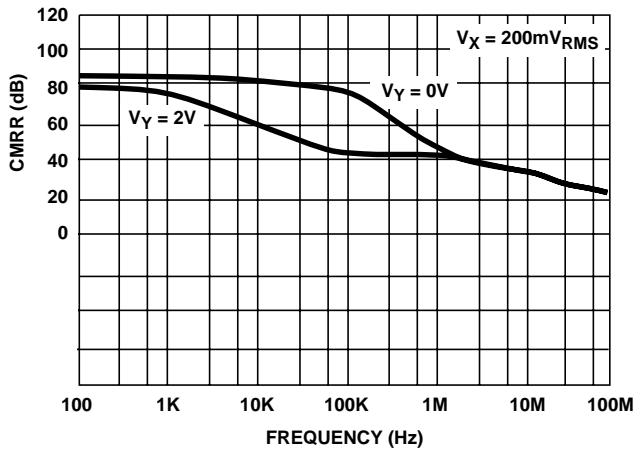

FIGURE 19.  $V_X$  COMMON MODE REJECTION RATIO vs FREQUENCY

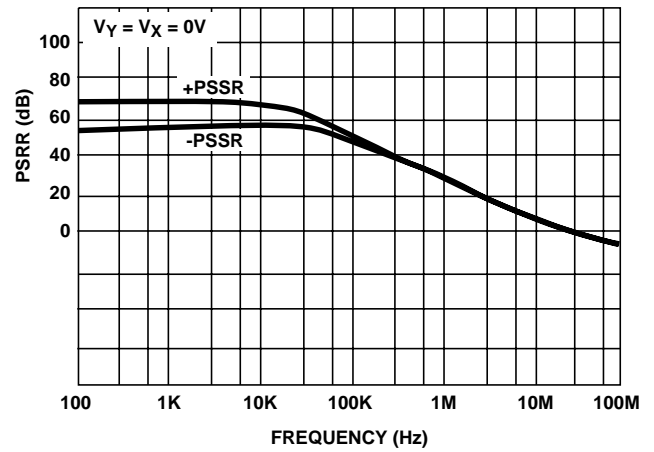

FIGURE 20. PSRR vs FREQUENCY

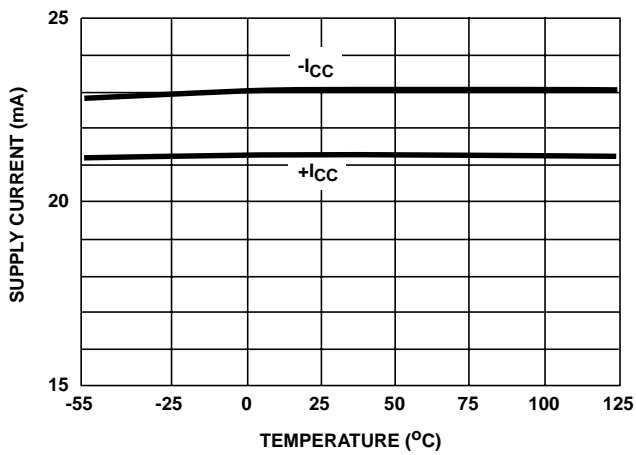

FIGURE 21. SUPPLY CURRENT vs TEMPERATURE

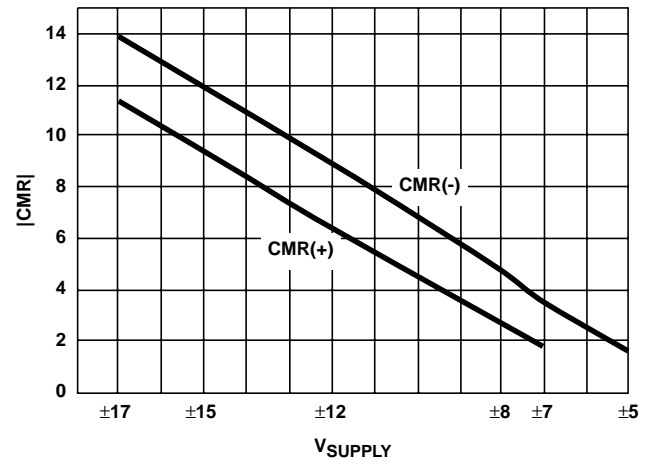

FIGURE 22. CMR vs  $V_{SUPPLY}$

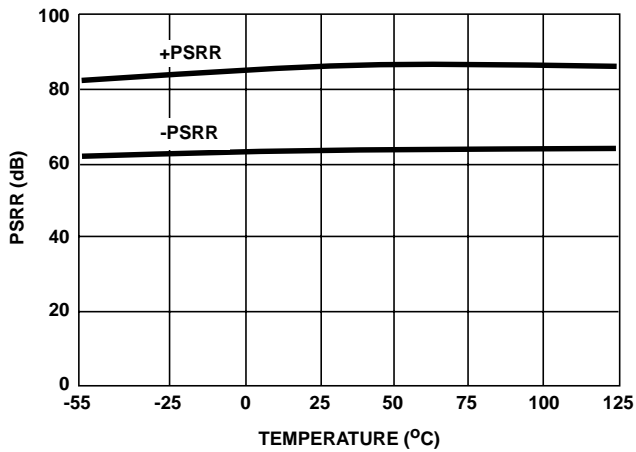

FIGURE 23. PSRR vs TEMPERATURE

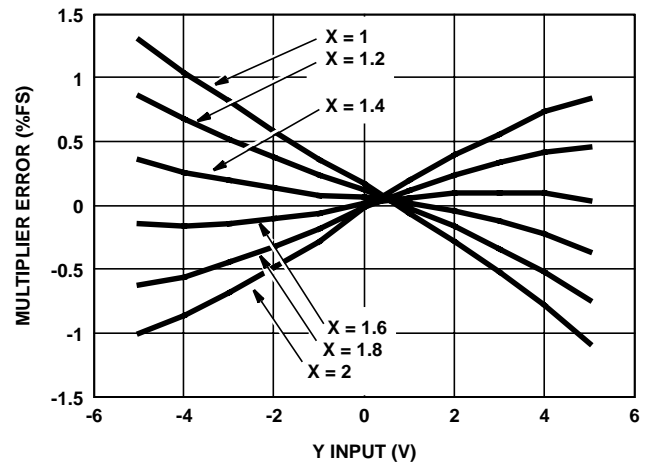

FIGURE 24. MULTIPLICATION ERROR vs  $V_Y$

**Typical Performance Curves**  $V_S = \pm 15V$ ,  $T_A = 25^\circ C$ , See Test Circuit For Multiplier Configuration (Continued)

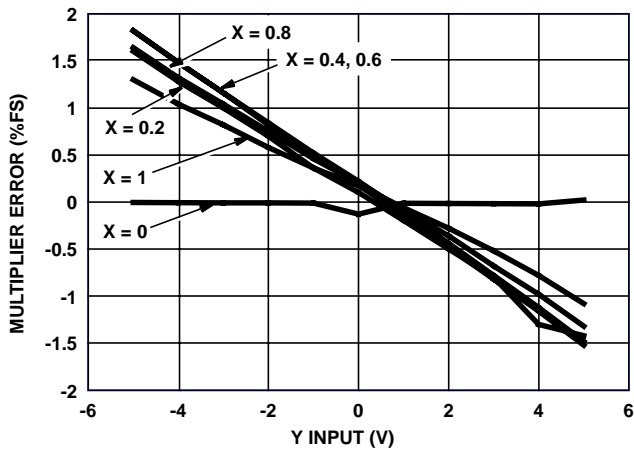

FIGURE 25.

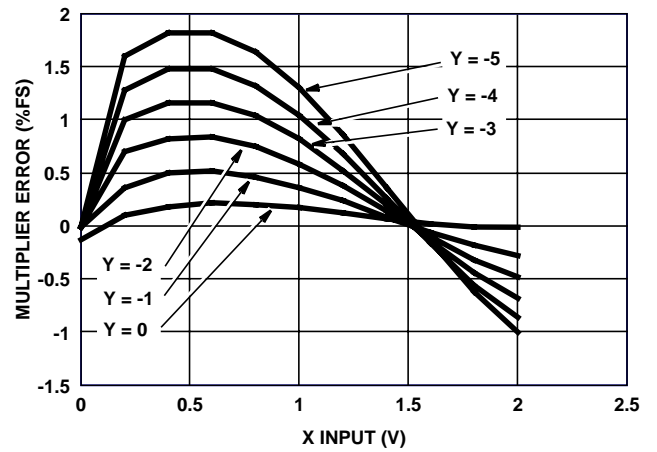

FIGURE 26.

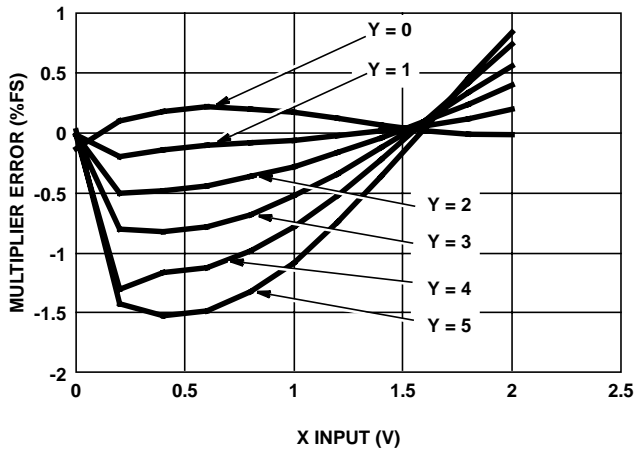

FIGURE 27.

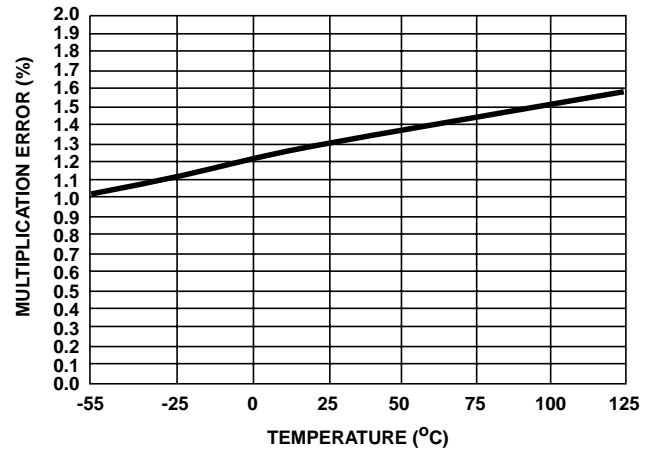

FIGURE 28. WORST CASE MULTIPLICATION ERROR vs TEMPERATURE

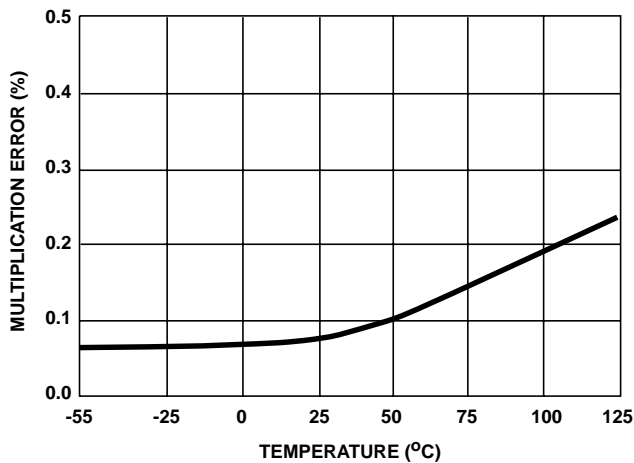

FIGURE 29. MULTIPLICATION ERROR vs TEMPERATURE

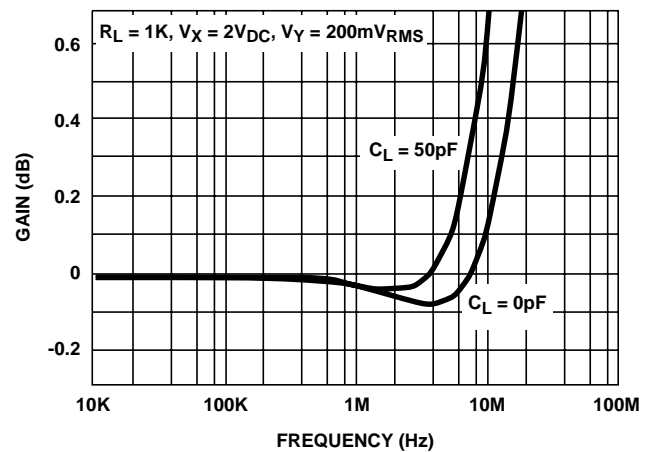

FIGURE 30. GAIN VARIATION vs FREQUENCY

**Typical Performance Curves**  $V_S = \pm 15V$ ,  $T_A = 25^\circ C$ , See Test Circuit For Multiplier Configuration (Continued)

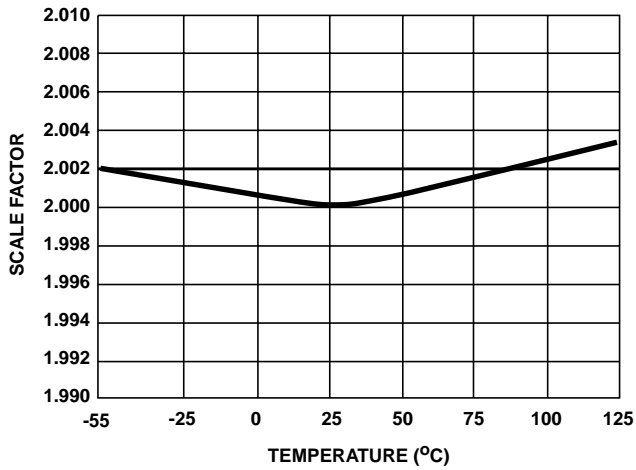

FIGURE 31. SCALE FACTOR vs TEMPERATURE

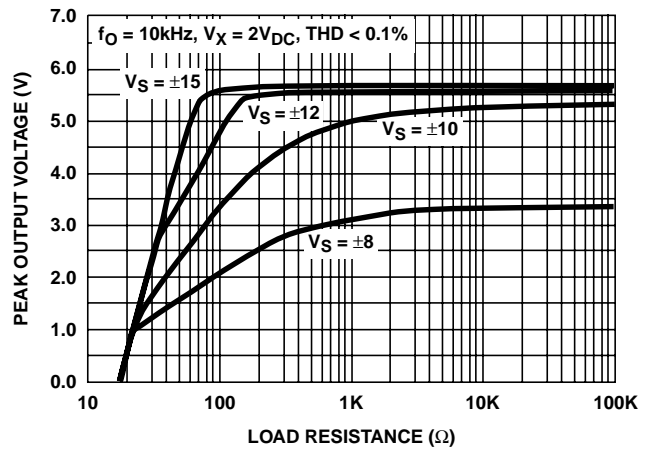

FIGURE 32. OUTPUT VOLTAGE SWING vs LOAD RESISTANCE

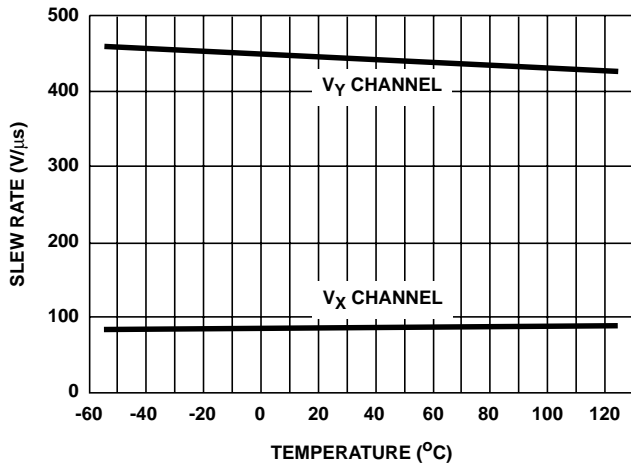

FIGURE 33. SLEW RATE vs TEMPERATURE

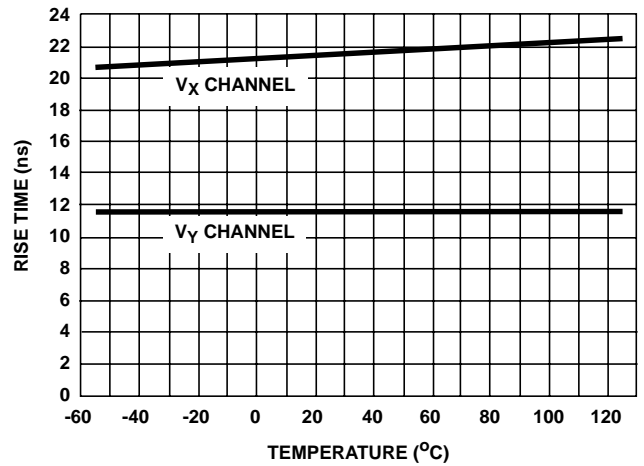

FIGURE 34. RISE TIME vs TEMPERATURE

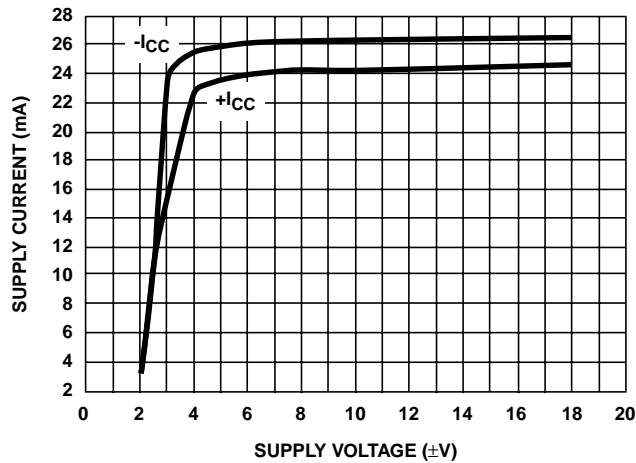

FIGURE 35. SUPPLY CURRENT vs SUPPLY VOLTAGE

**Die Characteristics**

**DIE DIMENSIONS:**

79.9 mils x 119.7 mils x 19 mils

**METALLIZATION:**

Type: Al, 1% CuI  
 Thickness:  $16\text{k}\text{\AA} \pm 2\text{k}\text{\AA}$

**PASSIVATION:**

Type: Nitride ( $\text{Si}_3\text{N}_4$ ) over Silox ( $\text{SiO}_2$ , 5% Phos)  
 Silox Thickness:  $12\text{k}\text{\AA} \pm 2\text{k}\text{\AA}$   
 Nitride Thickness:  $3.5\text{k}\text{\AA} \pm 2\text{k}\text{\AA}$

**TRANSISTOR COUNT:**

87

**Metallization Mask Layout**

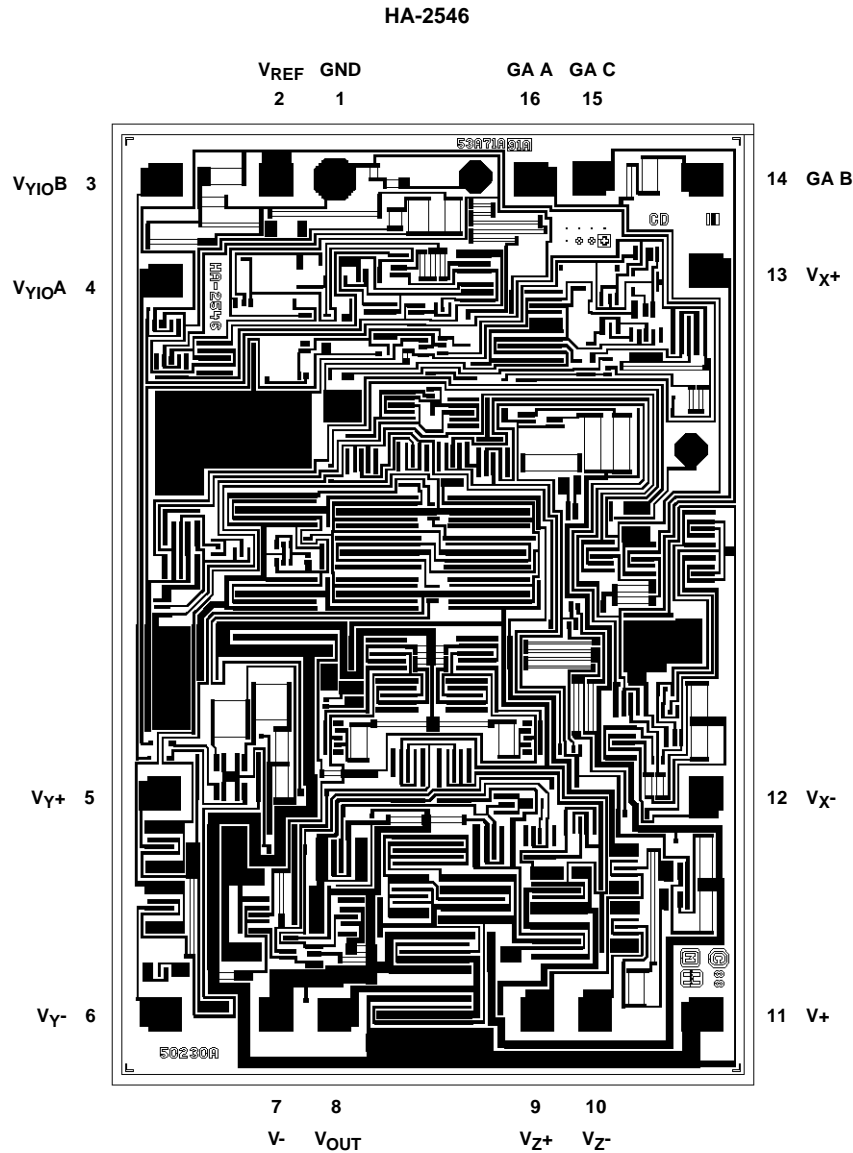

All Intersil semiconductor products are manufactured, assembled and tested under **ISO9000** quality systems certification.

*Intersil semiconductor products are sold by description only. Intersil Corporation reserves the right to make changes in circuit design and/or specifications at any time without notice. Accordingly, the reader is cautioned to verify that data sheets are current before placing orders. Information furnished by Intersil is believed to be accurate and reliable. However, no responsibility is assumed by Intersil or its subsidiaries for its use; nor for any infringements of patents or other rights of third parties which may result from its use. No license is granted by implication or otherwise under any patent or patent rights of Intersil or its subsidiaries.*

For information regarding Intersil Corporation and its products, see web site <http://www.intersil.com>

This datasheet has been downloaded from:

[www.DatasheetCatalog.com](http://www.DatasheetCatalog.com)

Datasheets for electronic components.



LittleDiode supplies new, hard to find or obsolete electronic components and semiconductors all over the world.

With over two million different components listed you are sure to find the part you need.

Feel free to visit us today at our online store:

[LittleDiode.com](http://LittleDiode.com)

Looking forward to providing you with the best possible service.