

HCC/HCF4029B

counter reaches its maximum count in the UP mode or the minimum count in the DOWN mode provided the CARRY-IN signal is low. The CARRY-IN signal in the low state can thus be considered a CLOCK ENABLE. The CARRY-IN terminal must be connected to V_{SS} when not in use. Binary counting is accomplished when the BINARY/DECADE input is high ; the counter counts in the decade mode when the BINARY/DECADE input is low. The counter

counts Up when to UP/DOWN INPUT is high, and Down when the UP/DOWN INPUT is low. Multiple packages can be connected in either a parallel-clocking or a ripple-clocking arrangement as shown in cascading counter packages. Parallel clocking provides synchronous control and hence faster response from all counting outputs. Ripple-clocking allows for longer clock input rise and fall times.

FUNCTIONAL DIAGRAM

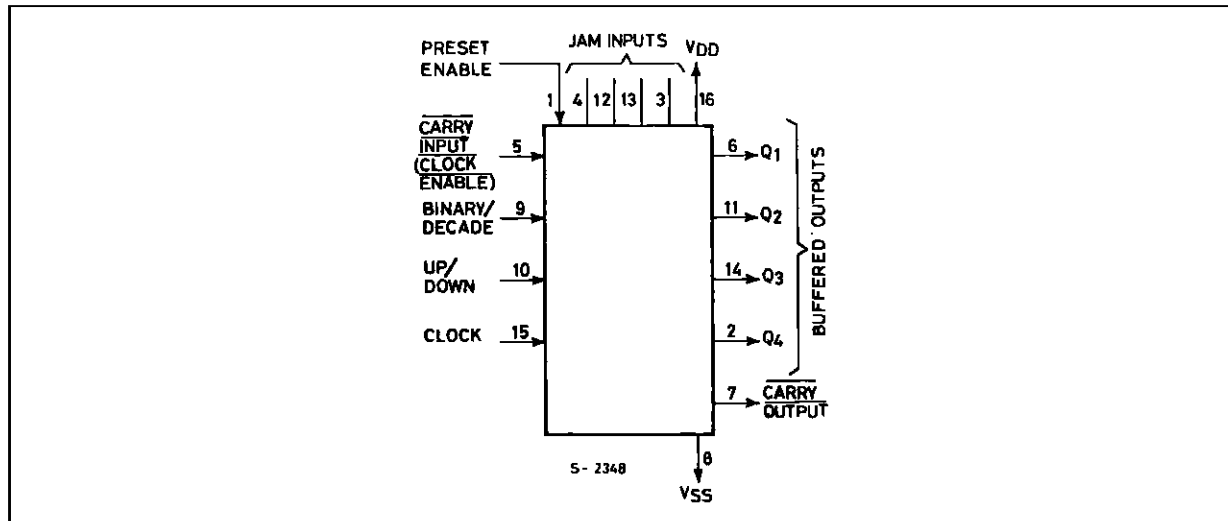

ABSOLUTE MAXIMUM RATING

Symbol	Parameter	Value	Unit
V _{DD} *	Supply Voltage: HCC Types HCF Types	-0.5 to +20 -0.5 to +18	V
V _i	Input Voltage	-0.5 to V _{DD} + 0.5	V
I _i	DC Input Current (any one input)	± 10	mA
P _{tot}	Total Power Dissipation (per package)	200	mW
	Dissipation per Output Transistor for Top = Full Package Temperature Range	100	mW
T _{op}	Operating Temperature: HCC Types HCF Types	-55 to +125 -40 to +85	°C
T _{stg}	Storage Temperature	-65 to +150	°C

Stresses above those listed under "Absolute Maximum Ratings" may cause permanent damage to the device. This is a stress rating only and functional operation of the device at these or any other conditions above those indicated in the operational sections of this specification is not implied. Exposure to absolute maximum rating conditions for external periods may affect device reliability.

All voltage values are referred to V_{SS} pin voltage.

RECOMMENDED OPERATING CONDITIONS

Symbol	Parameter	Value	Unit
V _{DD}	Supply Voltage: HCC Types	3 to 18	V
	HCF Types	3 to 15	V
V _I	Input Voltage	0 to V _{DD}	V
T _{op}	Operating Temperature: HCC Types	-55 to +125	°C
	HCF Types	-40 to +85	°C

LOGIC DIAGRAMS

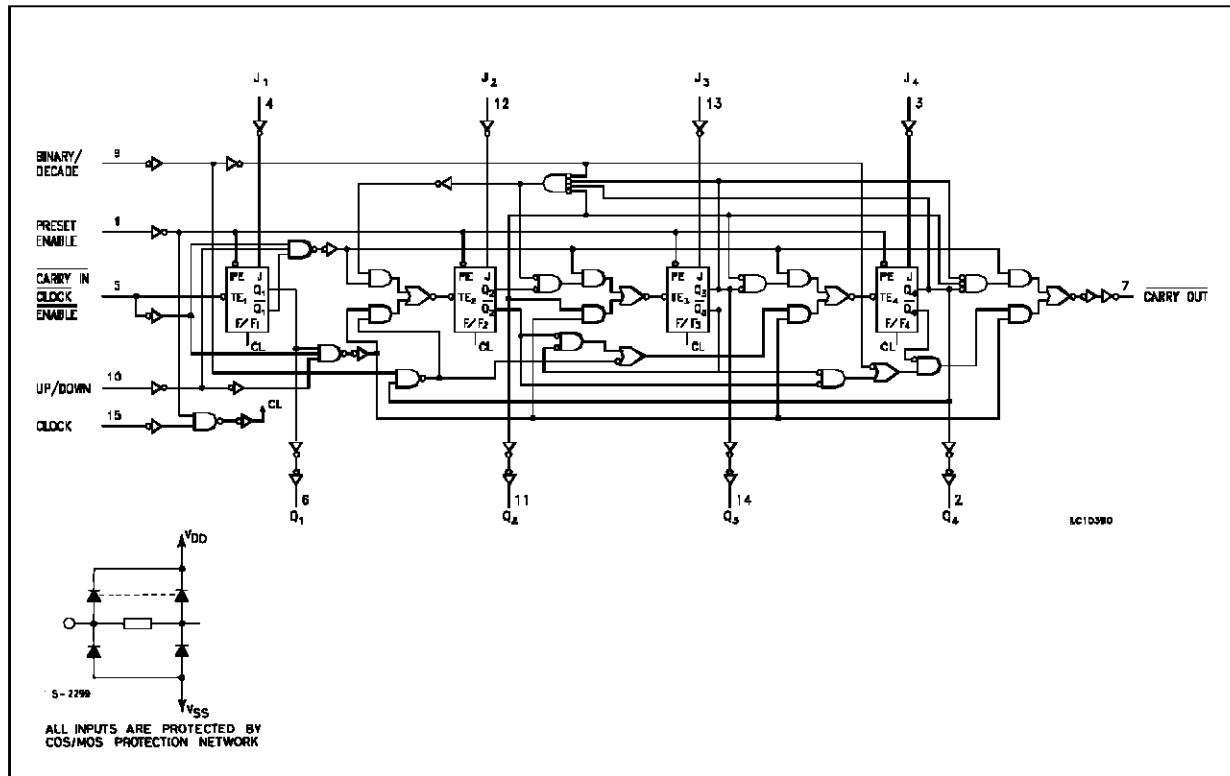

TRUTH TABLES

CLOCK	TE	PE	J	Q	\bar{Q}
X	X	0	0	0	1
$\overline{\text{L}}$	0	1	X	\bar{Q}	Q
X	X	0	1	1	0
$\overline{\text{L}}$	1	1	X	Q	\bar{Q} NC
$\overline{\text{L}}$	X	1	X	Q	\bar{Q} NC

X DONT CARE

Control Input	Logic Level	Action
BIN/DEC (B/D)	1	Binary Count
BIN/DEC (B/D)	0	Decade Count
UP/DOWN (U/D)	1	Up Count
UP/DOWN (U/D)	0	Down Count
Preset Enable (PE)	1	Jam In
Preset Enable (PE)	0	No Jam
Carry In (CI) (Clock Enable)	1	No Counter Advance at Pos. Clock Transition
	0	Advance Counter at Pos. Clock Transition

TIMING DIAGRAMS

Binary Mode

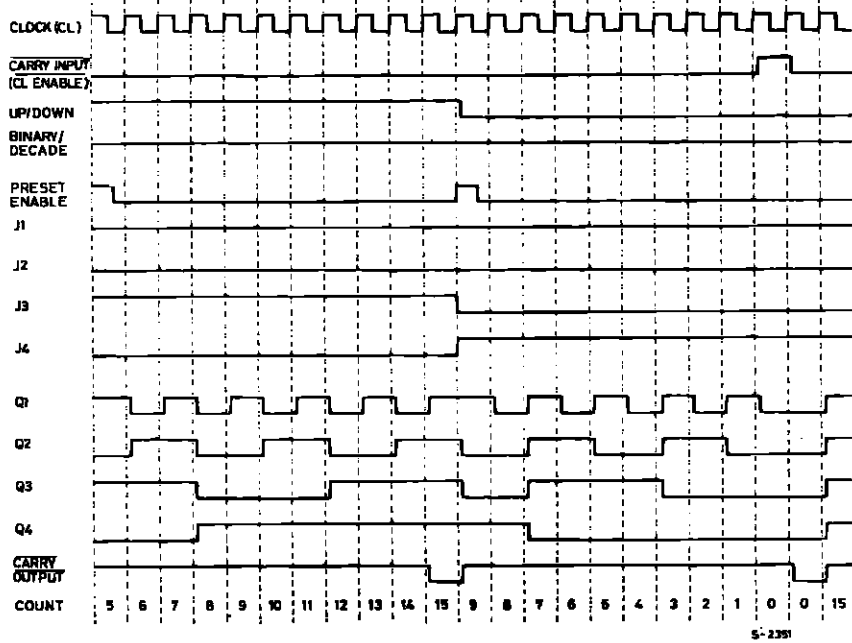

Decade Mode

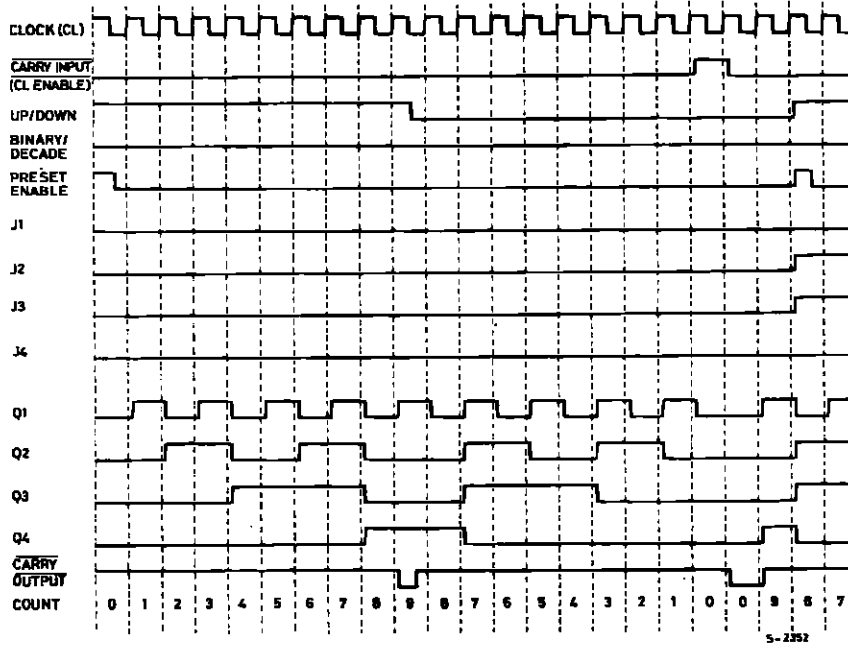

STATIC ELECTRICAL CHARACTERISTICS (over recommended operating conditions)

Symbol	Parameter		Test Conditions				Value						Unit	
			V _I (V)	V _O (V)	I _O (μ A)	V _{DD} (V)	T _{LOW} *		25 °C			T _{HIGH} *		
							Min.	Max.	Min.	Typ.	Max.	Min.		Max.
I _L	Quiescent Current	HCC Types	0/5			5		5		0.04	5		150	μ A
			0/10			10		10		0.04	10		300	
			0/15			15		20		0.04	20		600	
		0/20			20		100		0.08	100		3000		
		HCF Types	0/5			5		20		0.04	20		150	
			0/10			10		40		0.04	40		300	
0/15				15		80		0.04	80		600			
V _{OH}	Output High Voltage	0/5		< 1	5	4.95		4.95			4.95		V	
		0/10		< 1	10	9.95		9.95			9.95			
		0/15		< 1	15	14.95		14.95			14.95			
V _{OL}	Output Low Voltage	5/0		< 1	5		0.05			0.05		0.05	V	
		10/0		< 1	10		0.05			0.05		0.05		
		15/0		< 1	15		0.05			0.05		0.05		
V _{IH}	Input High Voltage	0.5/4.5	< 1	5	3.5			3.5				3.5	V	
		1/9	< 1	10	7			7				7		
		1.5/13.5	< 1	15	11			11				11		
V _{IL}	Input Low Voltage	4.5/0.5	< 1	5			1.5			1.5		1.5	V	
		9/1	< 1	10			3			3		3		
		13.5/1.5	< 1	15			4			4		4		
I _{OH}	Output Drive Current	HCC Types	0/5	2.5		5	-2		-1.6	-3.2		-1.15	mA	
			0/5	4.6		5	-0.64		-0.51	-1		-0.36		
			0/10	9.5		10	-1.6		-1.3	-2.6		-0.9		
		0/15	13.5		15	-4.2		-3.4	-6.8		-2.4			
		HCF Types	0/5	2.5		5	-1.53		-1.36	-3.2		-1.1		
			0/5	4.6		5	-0.52		-0.44	-1		-0.36		
0/10	9.5			10	-1.3		-1.1	-2.6		-0.9				
0/15	13.5		15	-3.6		-3.0	-6.8		-2.4					
I _{OL}	Output Sink Current	HCC Types	0/5	0.4		5	0.64		0.51	1		0.36	mA	
			0/10	0.5		10	1.6		1.3	2.6		0.9		
			0/15	1.5		15	4.2		3.4	6.8		2.4		
		HCF Types	0/5	0.4		5	0.52		0.44	1		0.36		
			0/10	0.5		10	1.3		1.1	2.6		0.9		
			0/15	1.5		15	3.6		3.0	6.8		2.4		
I _{IH} , I _{IL}	Input Leakage Current	HCC Types	0/18	Any Input		18		\pm 0.1		\pm 10 ⁻⁵	\pm 0.1		\pm 1	μ A
		HCF Types	0/15			15		\pm 0.3		\pm 10 ⁻⁵	\pm 0.3		\pm 1	
C _i	Input Capacitance			Any Input					5	7.5			pF	

* T_{LOW} = -55 °C for HCC device; -40 °C for HCF device.* T_{HIGH} = +125 °C for HCC device; +85 °C for HCF device.The Noise Margin for both "1" and "0" level is: 1V min. with V_{DD} = 5V, 2V min. with V_{DD} = 10V, 2.5V min. with V_{DD} = 15V

HCC/HCF4029B

DYNAMIC ELECTRICAL CHARACTERISTICS ($T_{amb} = 25\text{ }^{\circ}\text{C}$, $C_L = 50\text{ pF}$, $R_L = 200\text{ K}\Omega$, typical temperature coefficient for all V_{DD} values is $03\text{ } \%/^{\circ}\text{C}$, all input rise and fall times = 20 ns)

Symbol	Parameter	Test Conditions		Value			Unit
			V_{DD} (V)	Min.	Typ.	Max.	
t_{PLH} t_{PHL}	Propagation Delay Time (Q Outputs)		5		250	500	ns
			10		120	240	
			15		90	180	
t_{PLH} t_{PHL}	Propagation Delay Time (Carry Output)		5		280	560	ns
			10		130	260	
			15		95	190	
t_{TLH} t_{THL}	Transition Time (Q Outputs, Carry Output)		5		100	200	ns
			10		50	100	
			15		40	80	
t_w	Minimum Clock Pulse Width		5		90	180	ns
			10		45	90	
			15		30	60	
t_r , t_f^{**}	Clock Rise and Fall Time		5			15	μs
			10			15	
			15			15	
t_{setup}^*	Minimum Setup Time (Carry Input)		5		30	60	ns
			10		10	20	
			15		6	12	
t_{setup}	Minimum Setup Time (B/D or UD)		5		170	340	ns
			10		70	140	
			15		50	100	
f_{max}	Maximum Clock Input Frequency		5	2	4		MHz
			10	4	8		
			15	5.5	11		
PRESET ENABLE							
t_{PLH} t_{PHL}	Propagation Delay Time (Q Outputs)		5		235	470	ns
			10		100	200	
			15		80	160	
t_{PLH} t_{PHL}	Propagation Delay Time (Carry Output)		5		320	640	ns
			10		145	290	
			15		105	210	
t_w	Minimum Preset Enable (Pulse Width)		5		65	130	ns
			10		35	70	
			15		25	50	
t_{rem}^*	Minimum Preset Enable (Removal Time)		5		100	200	ns
			10		55	110	
			15		40	80	
CARRY INPUT							
t_{PHL} t_{PLH}	Propagation Delay Time (Carry Output)		5		170	340	ns
			10		70	140	
			15		50	100	
t_{setup}^{***}	Minimum Setup Time (Carry In)		5		25	50	ns
			10		15	30	
			15		12	25	
t_{hold}	Minimum Hold Time (Carry In)		5		100	200	ns
			10		35	70	
			15		30	60	

* From Up/Down, Binary/Decade, Carry In or Preset Enable Control Inputs to Clock Edge

** If more than one unit is cascaded in the parallel clocked application t_r should be made less than or equal to the sum of the fixed propagation delay at 15 pF and the transition time of the carry output driving stage for the estimated capacitance load.

*** From Carry in to Clock Edge.

Typical Output Low (sink) Current Characteristics.

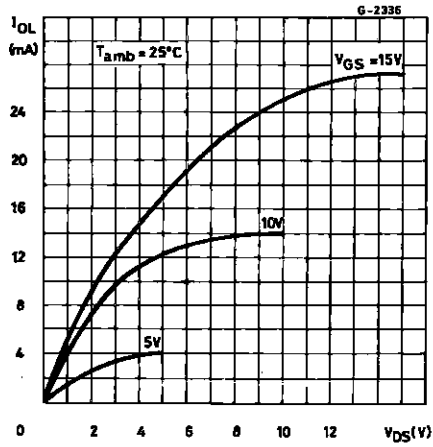

Minimum Output Low (sink) Current Characteristics.

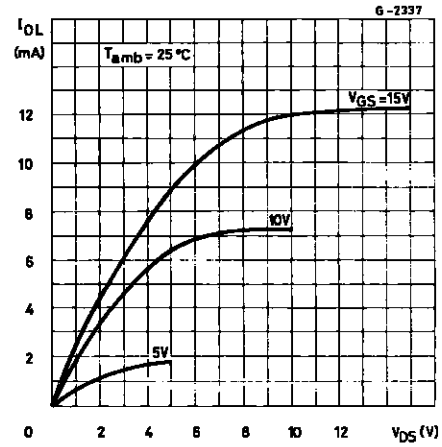

Typical Output High (source) Current Characteristics.

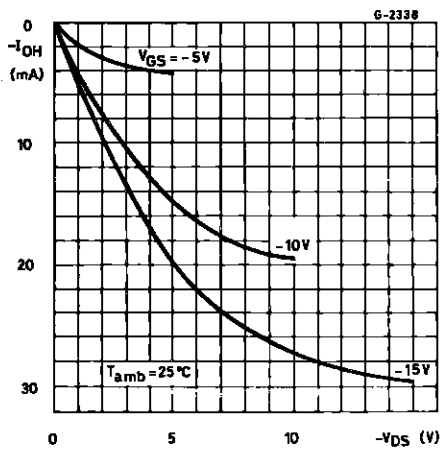

Minimum Output High (source) Current Characteristics.

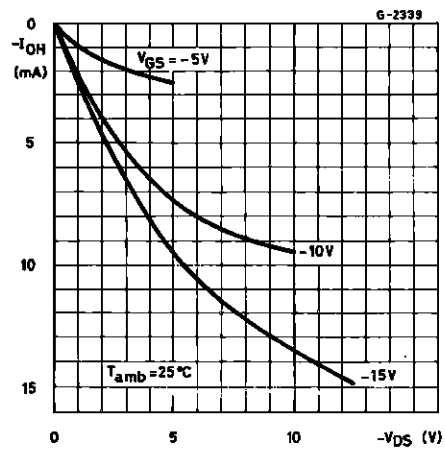

HCC/HCF4029B

APPLICATIONS

Conversion of Clock up, Clock Down Input Signals to Clock and Up/Down Inputs Signals.

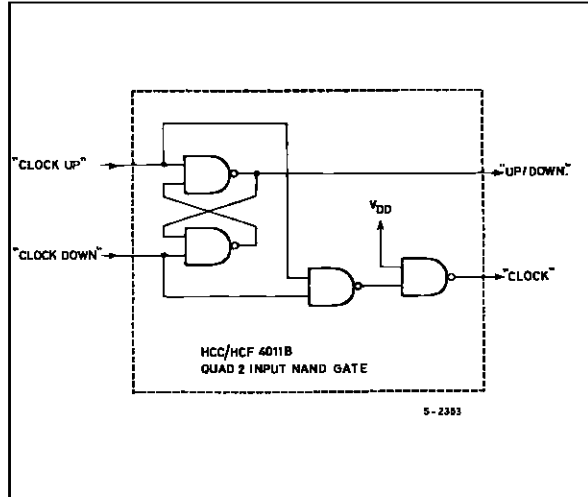

The **HCC/HCF4029B** CLOCK and UP/DOWN inputs are used directly in most applications. In applications where CLOCK UP and CLOCK DOWN inputs are provided, conversion to the **HCC/HCF4029B** CLOCK and UP/DOWN inputs can easily be realized by use of the circuit.

HCC/HCF4029B changes count on positive transitions of CLOCK UP or CLOCK DOWN inputs. For the gate configuration shown below, when counting up the CLOCK DOWN input must be maintained high and conversely when counting down the CLOCK UP input must be maintained high.

Cascading Counter Packages.

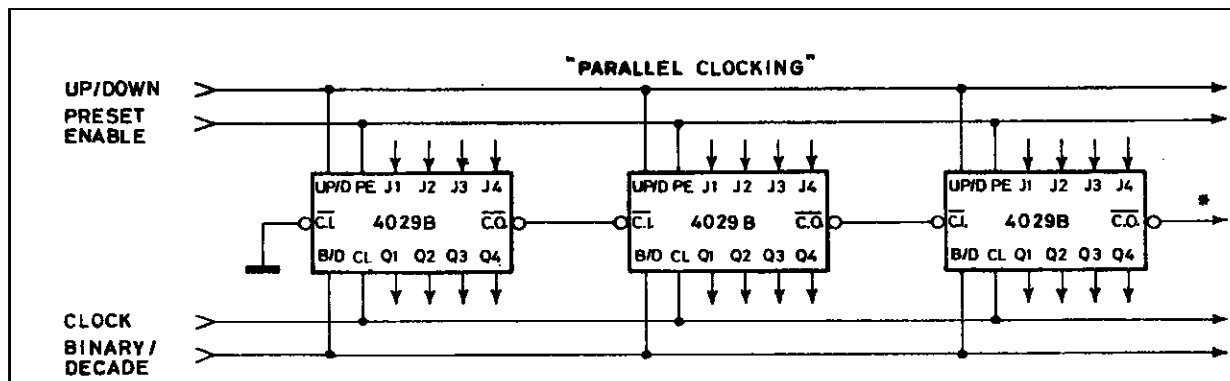

* CARRY-OUT lines at the 2nd, 3rd, etc., stages may have a negative-going glitch pulse resulting from differential delays of different **HCC/HCF4029B** IC's. These negative-going glitches do not affect proper **HCC/HCF4029B** operation. However, if the CARRY-OUT signals are used to trigger other edge-sensitive logic devices, such as FF's or counters, the CARRY-OUT signals should be gated with the clock signal using a 2-input NOR gate such as **HCC/HCF4001B**.

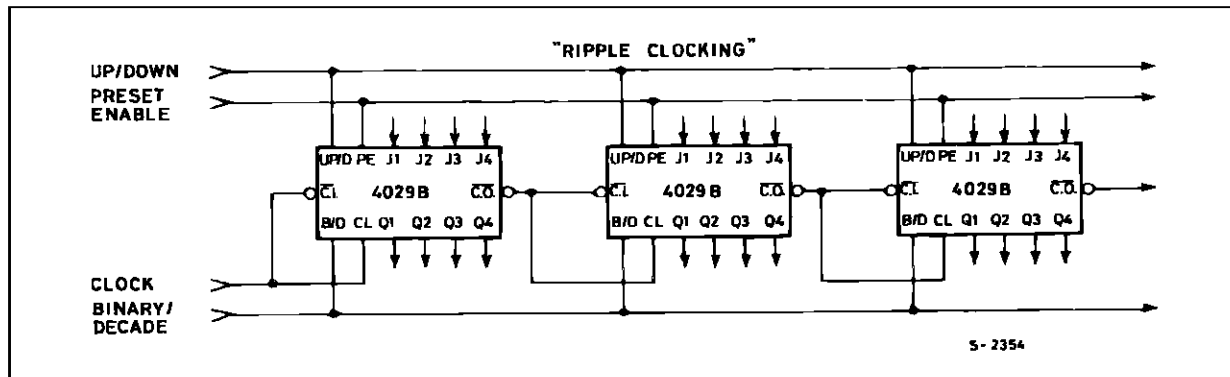

Ripple Clocking Mode: The Up/Down control can be changed at any count. The only restriction on changing the Up/Down control is that the clock input to the first counting stage must be high.

Plastic DIP16 (0.25) MECHANICAL DATA

DIM.	mm			inch		
	MIN.	TYP.	MAX.	MIN.	TYP.	MAX.
a1	0.51			0.020		
B	0.77		1.65	0.030		0.065
b		0.5			0.020	
b1		0.25			0.010	
D			20			0.787
E		8.5			0.335	
e		2.54			0.100	
e3		17.78			0.700	
F			7.1			0.280
I			5.1			0.201
L		3.3			0.130	
Z			1.27			0.050

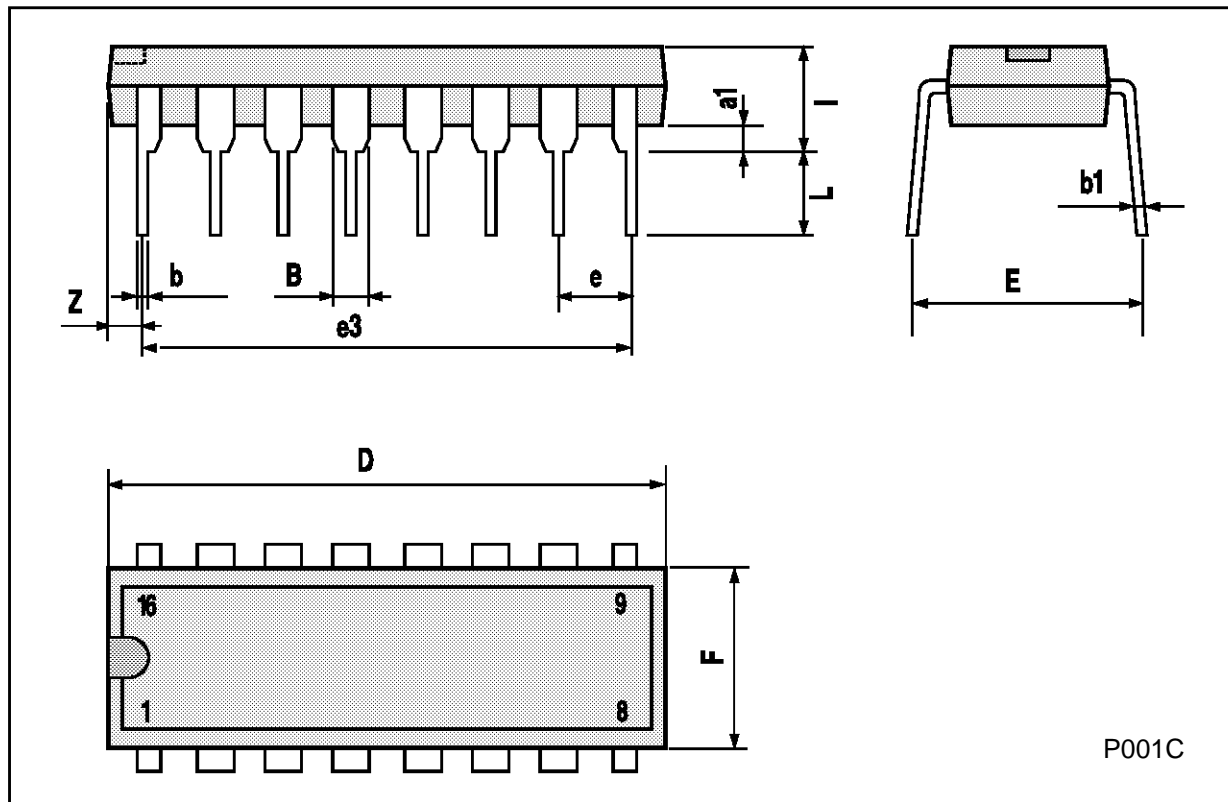

P001C

Ceramic DIP16/1 MECHANICAL DATA

DIM.	mm			inch		
	MIN.	TYP.	MAX.	MIN.	TYP.	MAX.
A			20			0.787
B			7			0.276
D		3.3			0.130	
E	0.38			0.015		
e3		17.78			0.700	
F	2.29		2.79	0.090		0.110
G	0.4		0.55	0.016		0.022
H	1.17		1.52	0.046		0.060
L	0.22		0.31	0.009		0.012
M	0.51		1.27	0.020		0.050
N			10.3			0.406
P	7.8		8.05	0.307		0.317
Q			5.08			0.200

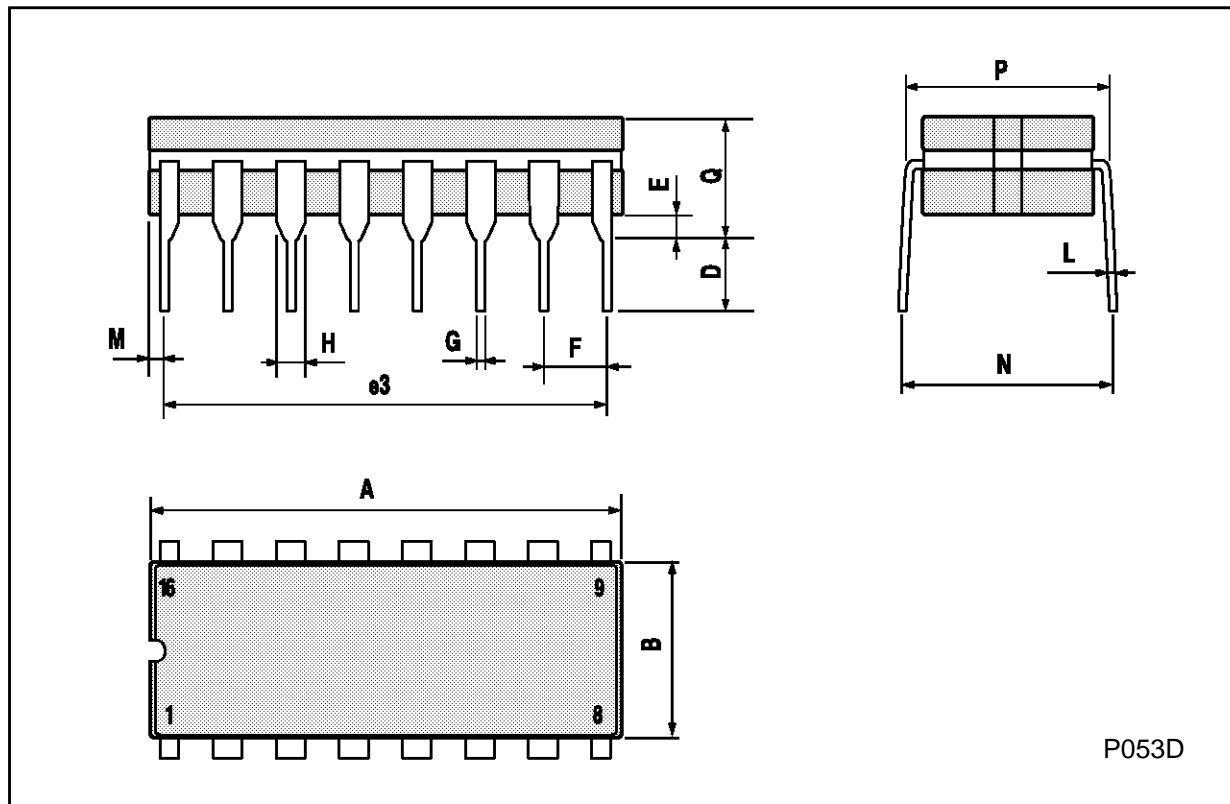

SO16 (Narrow) MECHANICAL DATA

DIM.	mm			inch		
	MIN.	TYP.	MAX.	MIN.	TYP.	MAX.
A			1.75			0.068
a1	0.1		0.2	0.004		0.007
a2			1.65			0.064
b	0.35		0.46	0.013		0.018
b1	0.19		0.25	0.007		0.010
C		0.5			0.019	
c1	45° (typ.)					
D	9.8		10	0.385		0.393
E	5.8		6.2	0.228		0.244
e		1.27			0.050	
e3		8.89			0.350	
F	3.8		4.0	0.149		0.157
G	4.6		5.3	0.181		0.208
L	0.5		1.27	0.019		0.050
M			0.62			0.024
S	8° (max.)					

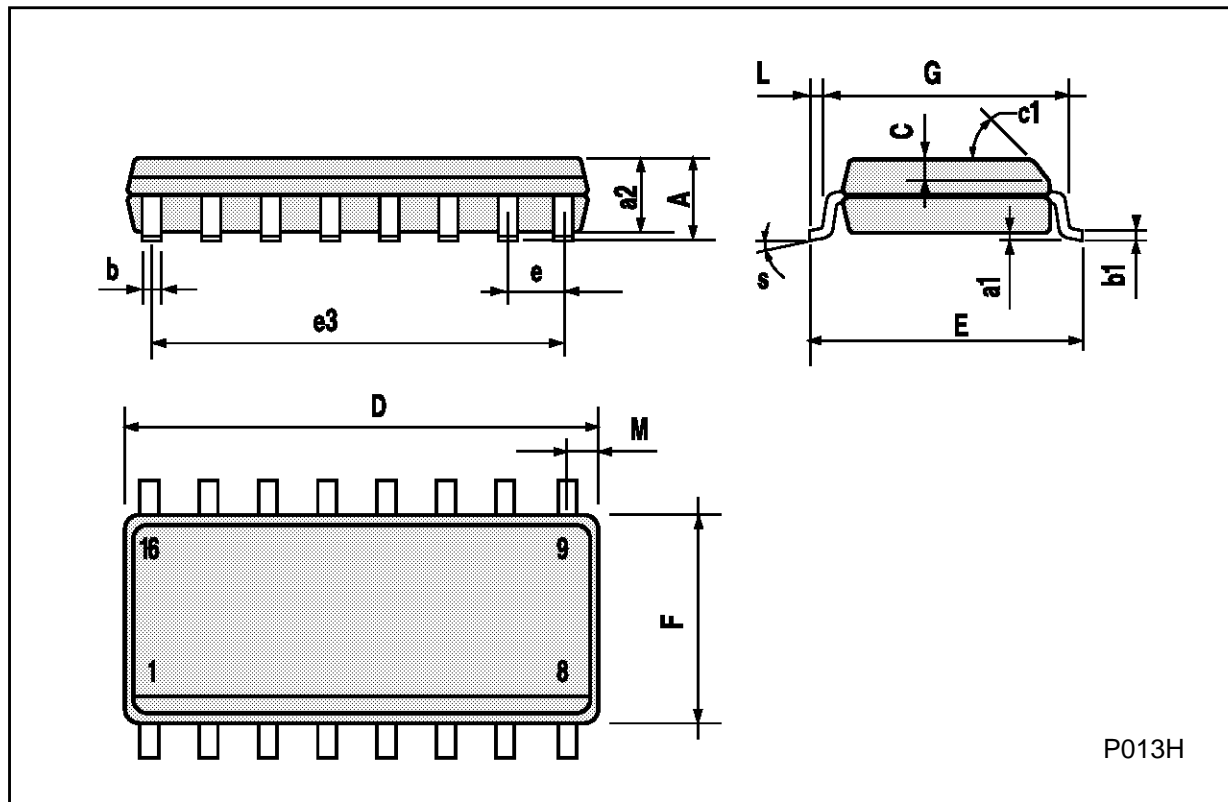

P013H

PLCC20 MECHANICAL DATA

DIM.	mm			inch		
	MIN.	TYP.	MAX.	MIN.	TYP.	MAX.
A	9.78		10.03	0.385		0.395
B	8.89		9.04	0.350		0.356
D	4.2		4.57	0.165		0.180
d1		2.54			0.100	
d2		0.56			0.022	
E	7.37		8.38	0.290		0.330
e		1.27			0.050	
e3		5.08			0.200	
F		0.38			0.015	
G			0.101			0.004
M		1.27			0.050	
M1		1.14			0.045	



Information furnished is believed to be accurate and reliable. However, SGS-THOMSON Microelectronics assumes no responsibility for the consequences of use of such information nor for any infringement of patents or other rights of third parties which may result from its use. No license is granted by implication or otherwise under any patent or patent rights of SGS-THOMSON Microelectronics. Specifications mentioned in this publication are subject to change without notice. This publication supersedes and replaces all information previously supplied. SGS-THOMSON Microelectronics products are not authorized for use as critical components in life support devices or systems without express written approval of SGS-THOMSON Microelectronics.

© 1994 SGS-THOMSON Microelectronics - All Rights Reserved

SGS-THOMSON Microelectronics GROUP OF COMPANIES

Australia - Brazil - France - Germany - Hong Kong - Italy - Japan - Korea - Malaysia - Malta - Morocco - The Netherlands -
Singapore - Spain - Sweden - Switzerland - Taiwan - Thailand - United Kingdom - U.S.A



LittleDiode supplies new, hard to find or obsolete electronic components and semiconductors all over the world.

With over two million different components listed you are sure to find the part you need.

Feel free to visit us today at our online store:

LittleDiode.com

Looking forward to providing you with the best possible service.