

# DATA SHEET

For a complete data sheet, please also download:

- The IC04 LOCMOS HE4000B Logic Family Specifications HEF, HEC
- The IC04 LOCMOS HE4000B Logic Package Outlines/Information HEF, HEC

## HEF40097B

### buffers

### 3-state hex non-inverting buffer

Product specification  
File under Integrated Circuits, IC04

January 1995

### 3-state hex non-inverting buffer

### HEF40097B buffers

**DESCRIPTION**

The HEF40097B is a hex non-inverting buffer with 3-state outputs. The 3-state outputs are controlled by two enable inputs ( $\overline{EO}_4$  and  $\overline{EO}_2$ ). A HIGH on  $\overline{EO}_4$  causes four of the six buffer elements to assume a high impedance or OFF-state, regardless of the other input conditions and a HIGH on  $\overline{EO}_2$  causes the outputs of the remaining two buffer elements to assume a high impedance or OFF-state, regardless of the other input conditions.

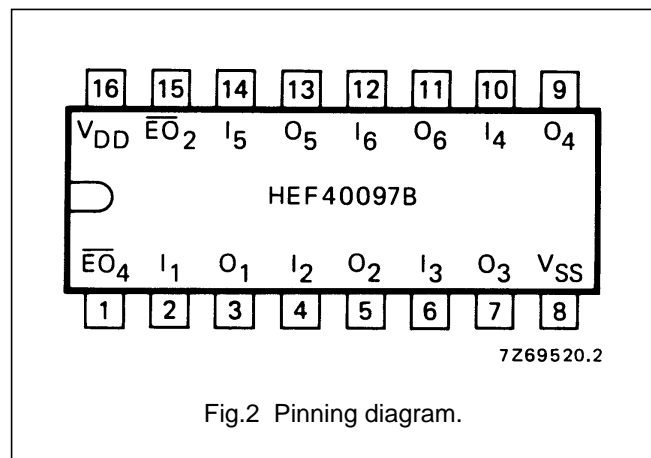
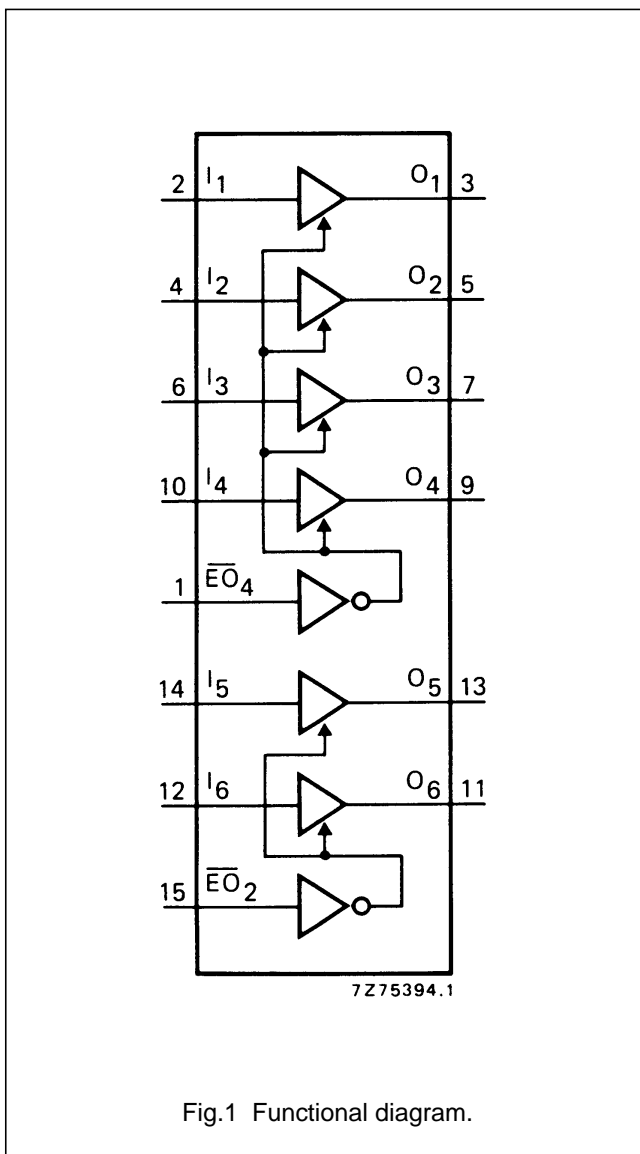

- HEF40097BP(N): 16-lead DIL; plastic (SOT38-1)
- HEF40097BD(F): 16-lead DIL; ceramic (cerdip) (SOT74)
- HEF40097BT(D): 16-lead SO; plastic (SOT109-1)
- ( ): Package Designator North America

**PINNING**

- $I_1$  to  $I_6$  buffer inputs
- $\overline{EO}_4$ ,  $\overline{EO}_2$  enable inputs (active LOW)
- $O_1$  to  $O_6$  buffer outputs (active HIGH)

**FAMILY DATA,  $I_{DD}$  LIMITS category BUFFERS**

See Family Specifications

3-state hex non-inverting buffer

HEF40097B  
buffers

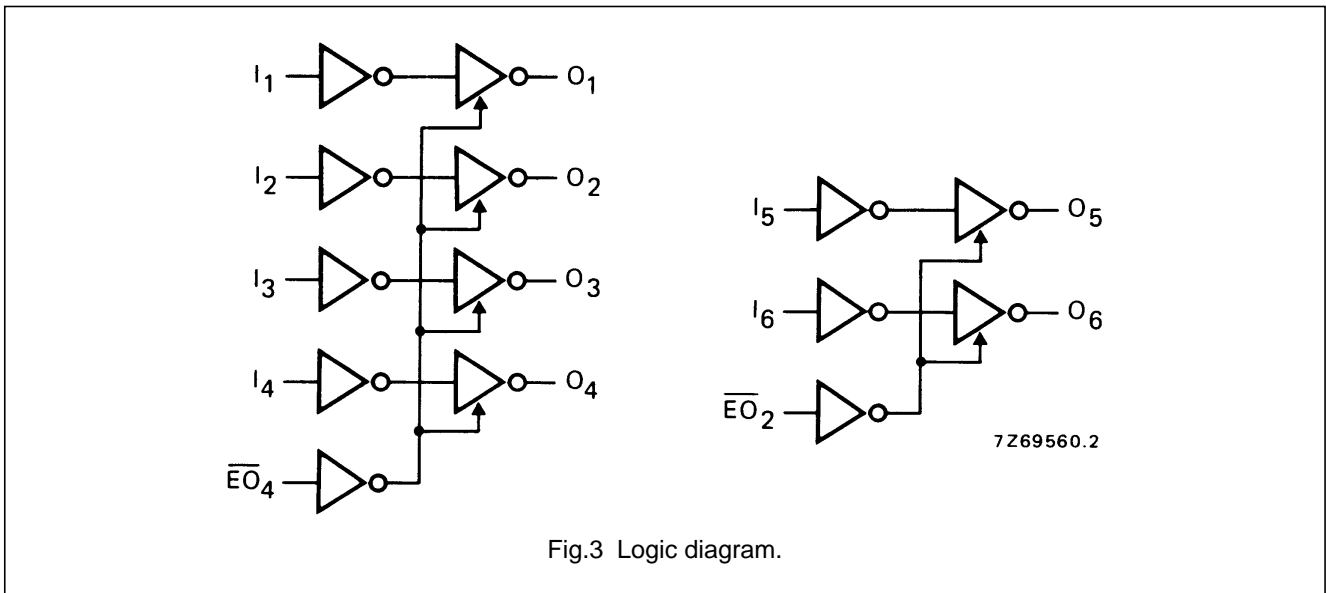

DC CHARACTERISTICS

V<sub>SS</sub> = 0 V

HEF	V <sub>DD</sub> V	V <sub>OH</sub> V	V <sub>OL</sub> V	SYMBOL	T <sub>amb</sub> (°C)					
					-40		+25		+85	
					MIN.	MAX.	MIN.	MAX.	MIN.	MAX.
Output current HIGH	5	4,6		-I <sub>OH</sub>	1,2	1,0	0,8	mA		
	10	9,5			3,8	3,2	2,5	mA		
	15	13,5			12,0	10,0	8,0	mA		
HIGH	5	2,5		-I <sub>OH</sub>	3,8	3,2	2,5	mA		
Output current LOW	4,75		0,4	I <sub>OL</sub>	3,5	2,9	2,3	mA		
	10		0,5		12,0	10,0	8,0	mA		
	15		1,5		24,0	20,0	16,0	mA		

HEC	V <sub>DD</sub> V	V <sub>OH</sub> V	V <sub>OL</sub> V	SYMBOL	T <sub>amb</sub> (°C)					
					-55		+25		+125	
					MIN.	MAX.	MIN.	MAX.	MIN.	MAX.
Output current HIGH	5	4,6		-I <sub>OH</sub>	1,25	1,0	0,6	mA		
	10	9,5			4,0	3,2	2,1	mA		
	15	13,5			12,5	10,0	6,7	mA		
HIGH	5	2,5		-I <sub>OH</sub>	4,0	3,2	2,1	mA		
Output current LOW	4,75		0,4	I <sub>OL</sub>	3,6	2,9	1,9	mA		
	10		0,5		12,5	10,0	6,7	mA		
	15		1,5		25,0	20,0	13,0	mA		

## 3-state hex non-inverting buffer

HEF40097B  
buffers

## AC CHARACTERISTICS

 $V_{SS} = 0$  V;  $T_{amb} = 25$  °C;  $C_L = 50$  pF; input transition times  $\leq 20$  ns

	$V_{DD}$ V	SYMBOL	TYP.	MAX.		TYPICAL EXTRAPOLATION FORMULA
Propagation delays $I_n \rightarrow O_n$ HIGH to LOW	5	$t_{PHL}$	70	140	ns	60 ns + (0,20 ns/pF) $C_L$
	10		30	60	ns	26 ns + (0,08 ns/pF) $C_L$
	15		25	50	ns	22 ns + (0,06 ns/pF) $C_L$
LOW to HIGH	5	$t_{PLH}$	60	120	ns	45 ns + (0,30 ns/pF) $C_L$
	10		25	50	ns	19 ns + (0,13 ns/pF) $C_L$
	15		20	40	ns	16 ns + (0,09 ns/pF) $C_L$
Output transition times HIGH to LOW	5	$t_{THL}$	30	60	ns	15 ns + (0,30 ns/pF) $C_L$
	10		15	30	ns	10 ns + (0,11 ns/pF) $C_L$
	15		10	20	ns	7 ns + (0,07 ns/pF) $C_L$
LOW to HIGH	5	$t_{TLH}$	35	70	ns	10 ns + (0,50 ns/pF) $C_L$
	10		20	40	ns	8 ns + (0,24 ns/pF) $C_L$
	15		15	30	ns	6 ns + (0,18 ns/pF) $C_L$
3-state propagation delays Output disable times $\overline{EO}_2, \overline{EO}_4 \rightarrow O_n$ HIGH	5	$t_{PHZ}$	45	95	ns	
	10		35	70	ns	
	15		30	60	ns	
LOW	5	$t_{PLZ}$	60	120	ns	
	10		35	70	ns	
	15		25	55	ns	
Output enable times $\overline{EO}_2, \overline{EO}_4 \rightarrow O_n$ HIGH	5	$t_{PZH}$	75	150	ns	
	10		35	70	ns	
	15		30	60	ns	
LOW	5	$t_{PZL}$	95	190	ns	
	10		40	80	ns	
	15		30	65	ns	

	$V_{DD}$ V	TYPICAL FORMULA FOR P ( $\mu$ W)	
Dynamic power dissipation per package (P)	5	$5\ 400 f_i + \sum (f_o C_L) \times V_{DD}^2$	where $f_i$ = input freq. (MHz) $f_o$ = output freq. (MHz) $C_L$ = load cap. (pF) $\sum (f_o C_L)$ = sum of outputs $V_{DD}$ = supply voltage (V)
	10	$25\ 200 f_i + \sum (f_o C_L) \times V_{DD}^2$	
	15	$96\ 500 f_i + \sum (f_o C_L) \times V_{DD}^2$	



LittleDiode supplies new, hard to find or obsolete electronic components and semiconductors all over the world.

With over two million different components listed you are sure to find the part you need.

Feel free to visit us today at our online store:

[LittleDiode.com](http://LittleDiode.com)

Looking forward to providing you with the best possible service.